



GKF 3005
Capsule Filling Machine
Replacement Spare Parts & Service

Custom Parts/Specialty Parts
Available On Request

INTERNATIONAL INVENTORY MANAGEMENT

456 MANNING AVENUE
ELON, NC 27244 USA
TEL 001 336 584 4777
sales@iimnc.com

www.iimnc.com

revised 8/8/23

OEM names and part numbers are used to identify replacement parts. Our products are not affiliated with, sponsored, or approved by the original equipment manufacturer.

Table of Contents

GKF 3005 - 21 COUNT

Section	Description	Section	Description
1	Main Drive Motor	27	Capsule Magazine Mounts
1	Main Drive Gearbox	28	Capsule Sorting - 10CT
1	Main Drive Shaft	29	Capsule Sorting - 10CT
2	Tamping Cam	30	Capsule Infeed Hopper
3	Sorting Cam	31	Faulty Capsule Ejection
3	Separation Cam	32	Faulty Capsule Ejection 9CT
3	Closing Cam	33	Faulty Capsule Ejection 12CT
3	Faulty Cap. Ejection Cam	34	Powder Dosing
4	Ejection Cam	34	Powder Bowl & Guide Ring
5	Belt Tensioner	35	Tamping Head
6	Belt Tensioner	36	Eject/Clean Station 3 Shaft
7	Segment Carriers	36.1	Eject/Clean Station 2 Shaft
7	Segment Turret	37	Cleaning Station
7	Segment Gearbox		Index
8	Sorting Drive		
9	Separation Drive		
10	Tamping Station		
11	Dosing Station & Gearbox		
12	Powder Motor & Gearbox		
13	Powder Auger & Hopper		
13.1	Auger Upgrades		
14	Eject Drive - New - 3 Shaft		
14.1	Eject Drive - Old - 2 Shaft		
14.2	Eject Drive - Old - 2 Shaft		
15	Dosing Base with Disc		
16	Powder Tamping Ring		
16	Dosing Disc		
17	Size Change Parts 21CT		
18	Size Change Parts 10CT		
19	Size Change Parts 11CT		
20	Segment Cam		
21	Closing Station		
22	Closing Pins		
23	Vacuum Station		
24	Capsule Sorting - 11CT		
25	Capsule Separation 10CT		
26	Capsule Separation 11CT		

Section 1: Main Drive (Motor, Gearbox & Shaft)

GKF3005 - revised 3/1/2022

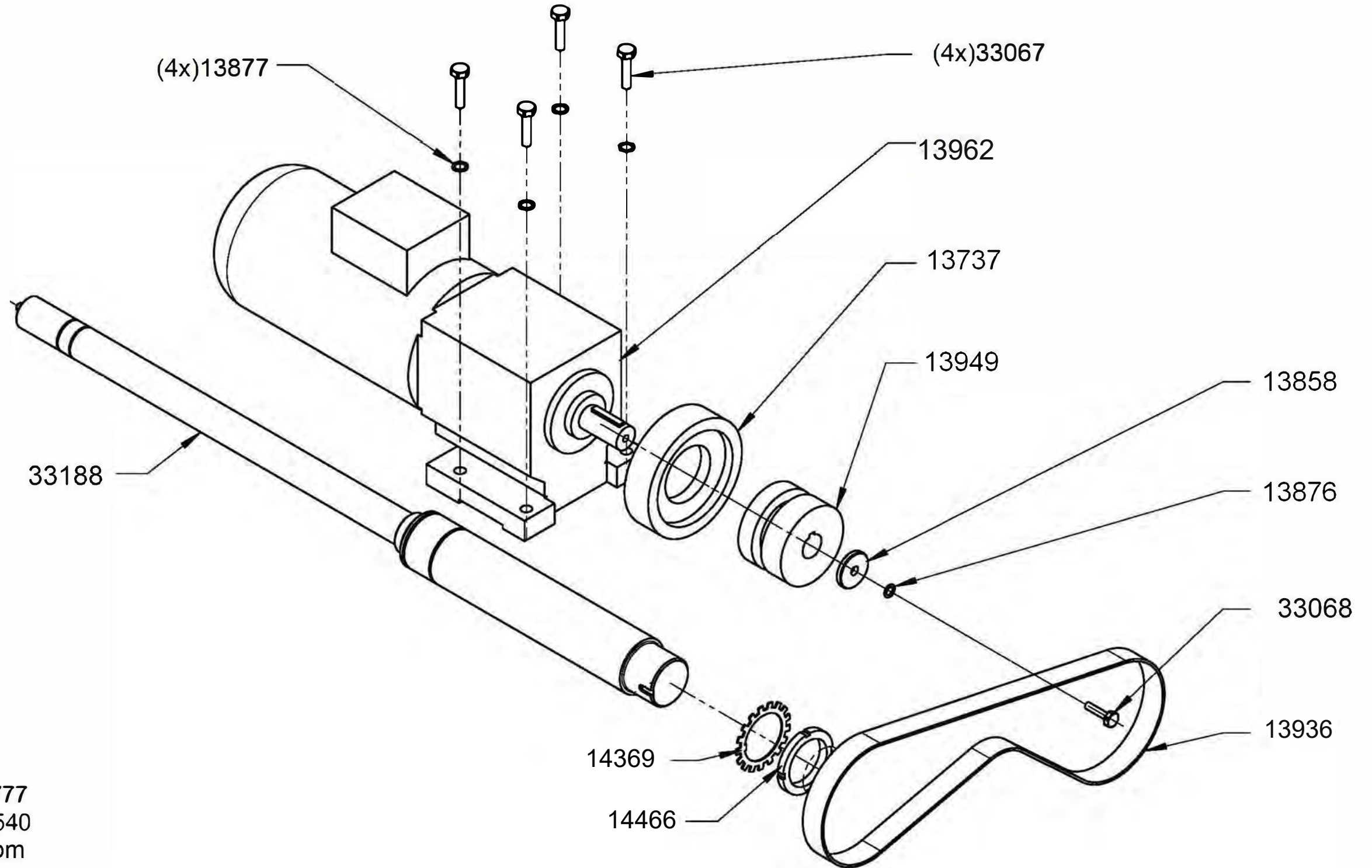

IIM
tel (336) 584-4777
fax (336) 584-9540
sales@iimnc.com
www.iimnc.com

Section 2: Tamping Cam

GKF3005 - revised 3/1/2022

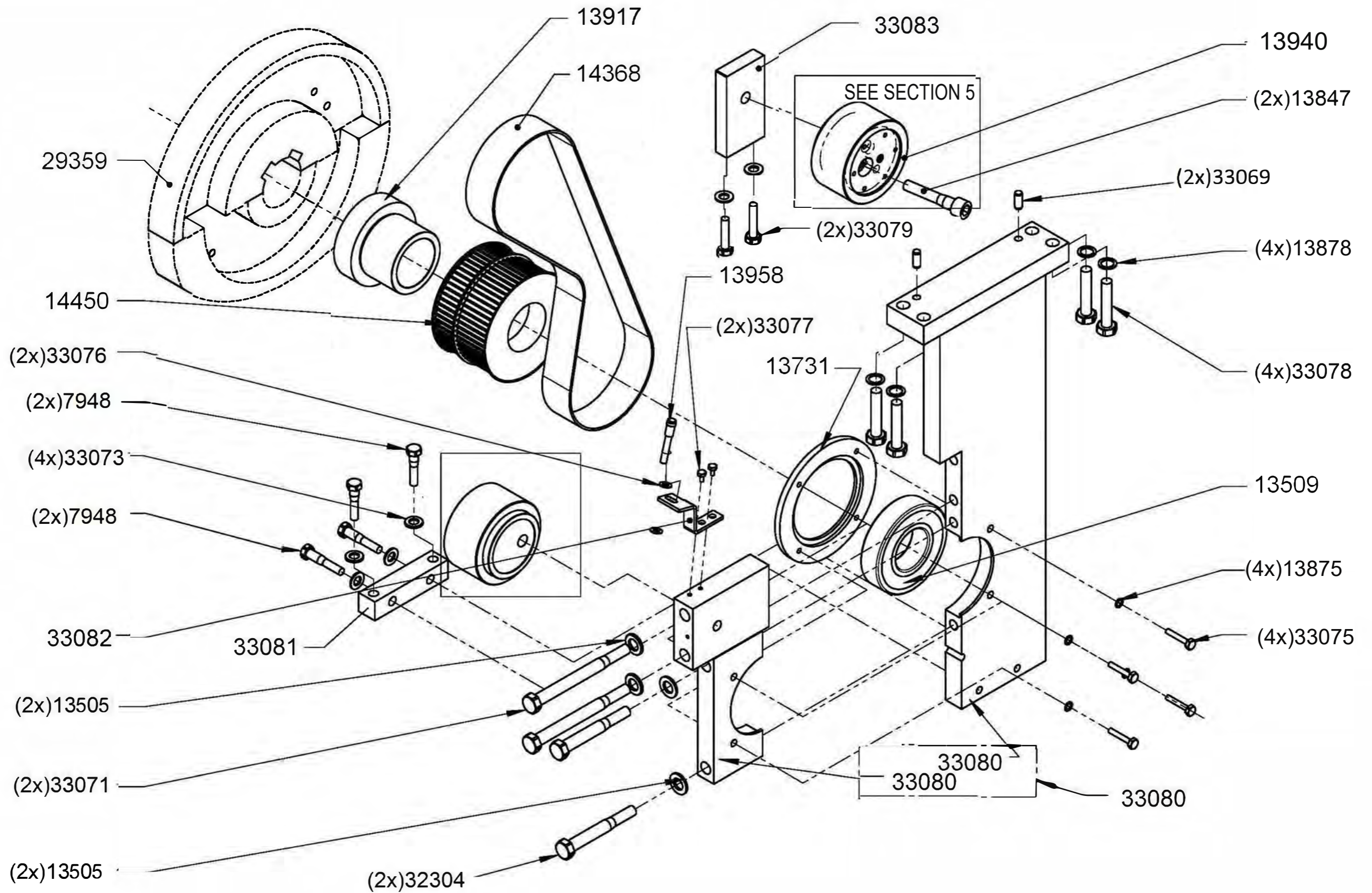

Section 3: Sorting Cam / Separation Cam / Closing Cam / Faulty Capsule Ejection Cam

GKF3005 - revised 3/1/2022

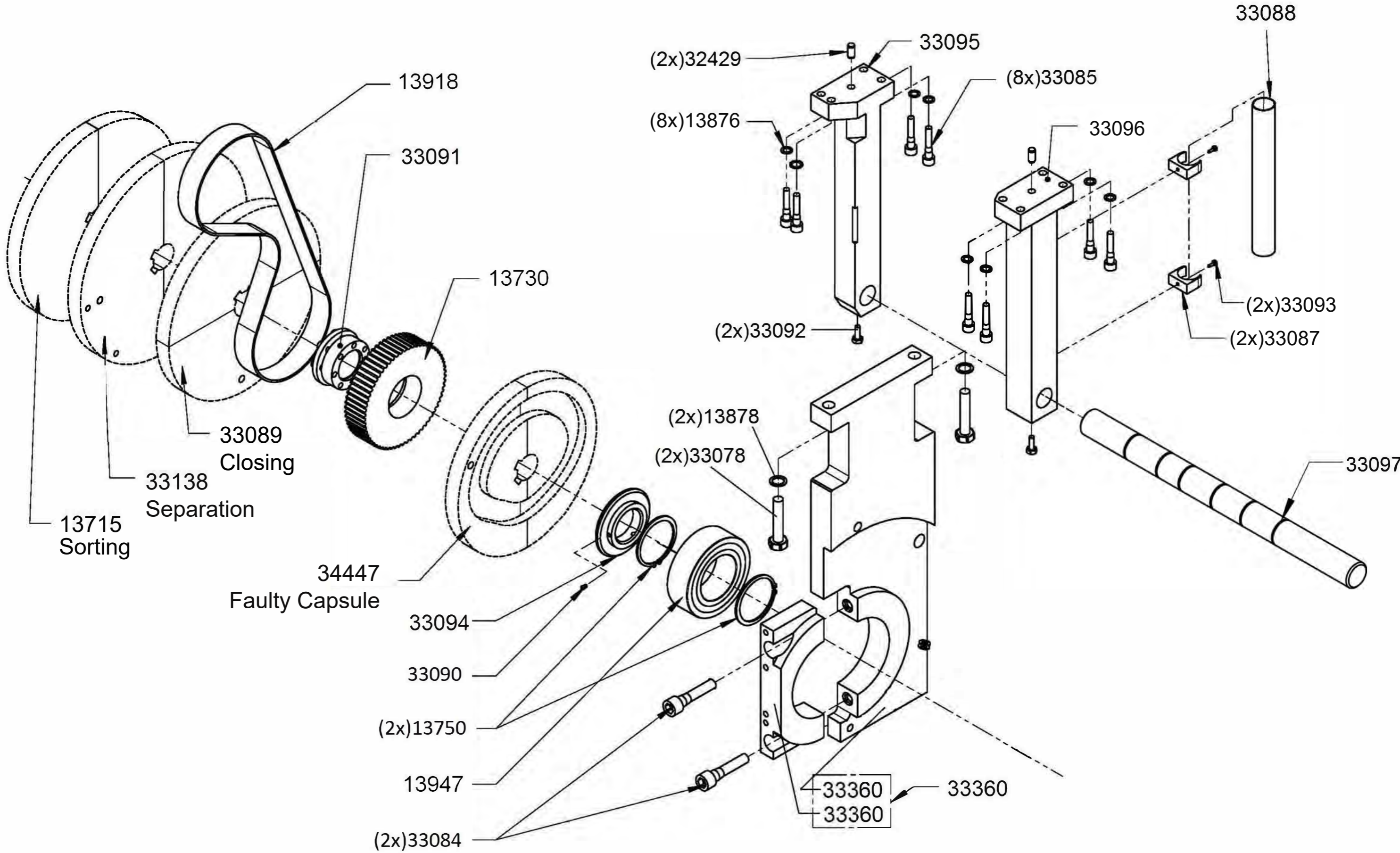

IIM
 tel (336) 584-4777
 fax (336) 584-9540
 sales@iimnc.com
 www.iimnc.com

Section 4: Ejection Cam

GKF3005 - revised 11/172022

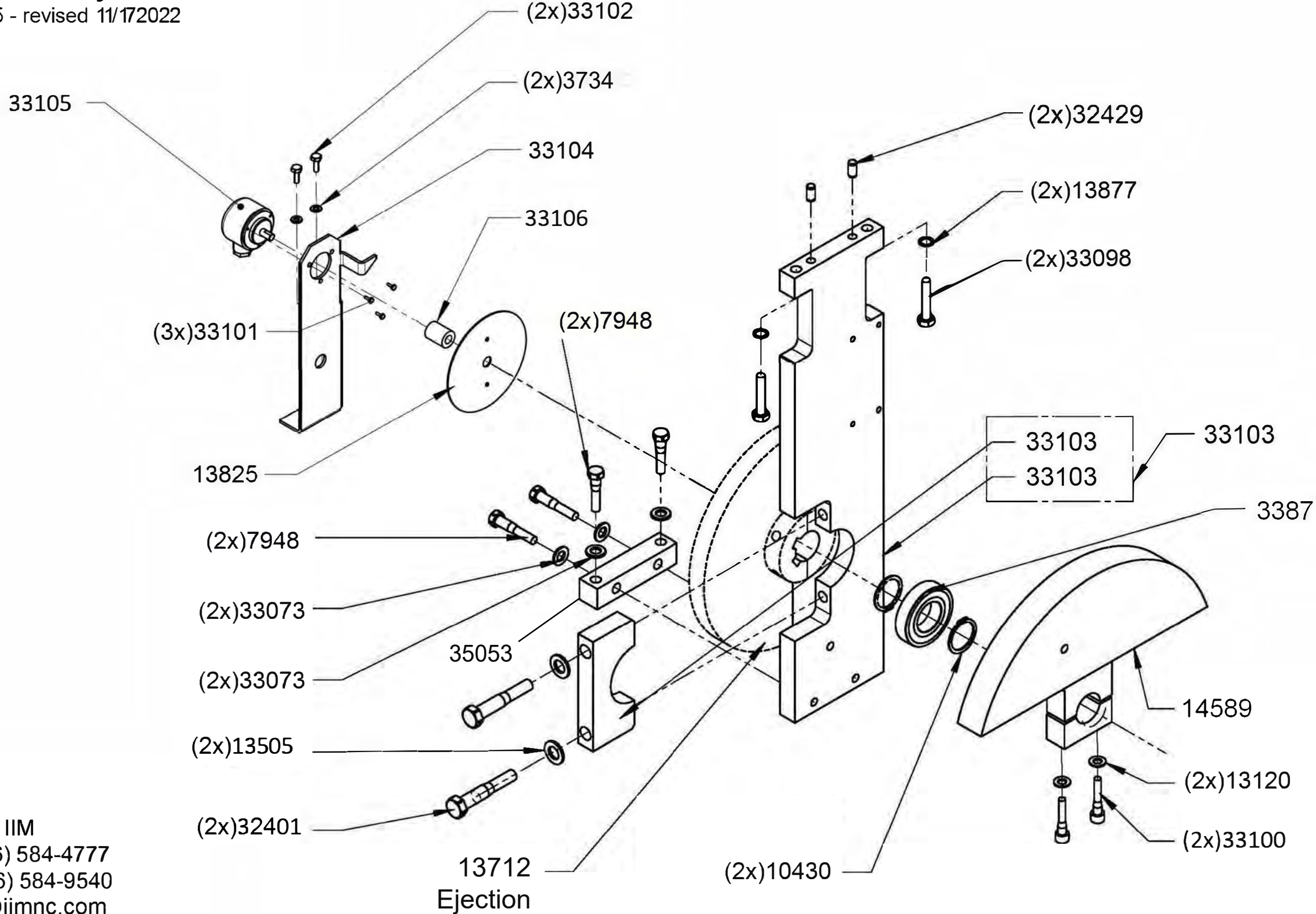

IIM
tel (336) 584-4777
fax (336) 584-9540
sales@iimnc.com
www.iimnc.com

Section 5: Belt Tensioner

GKF3005 - revised 3/1/2022

13940

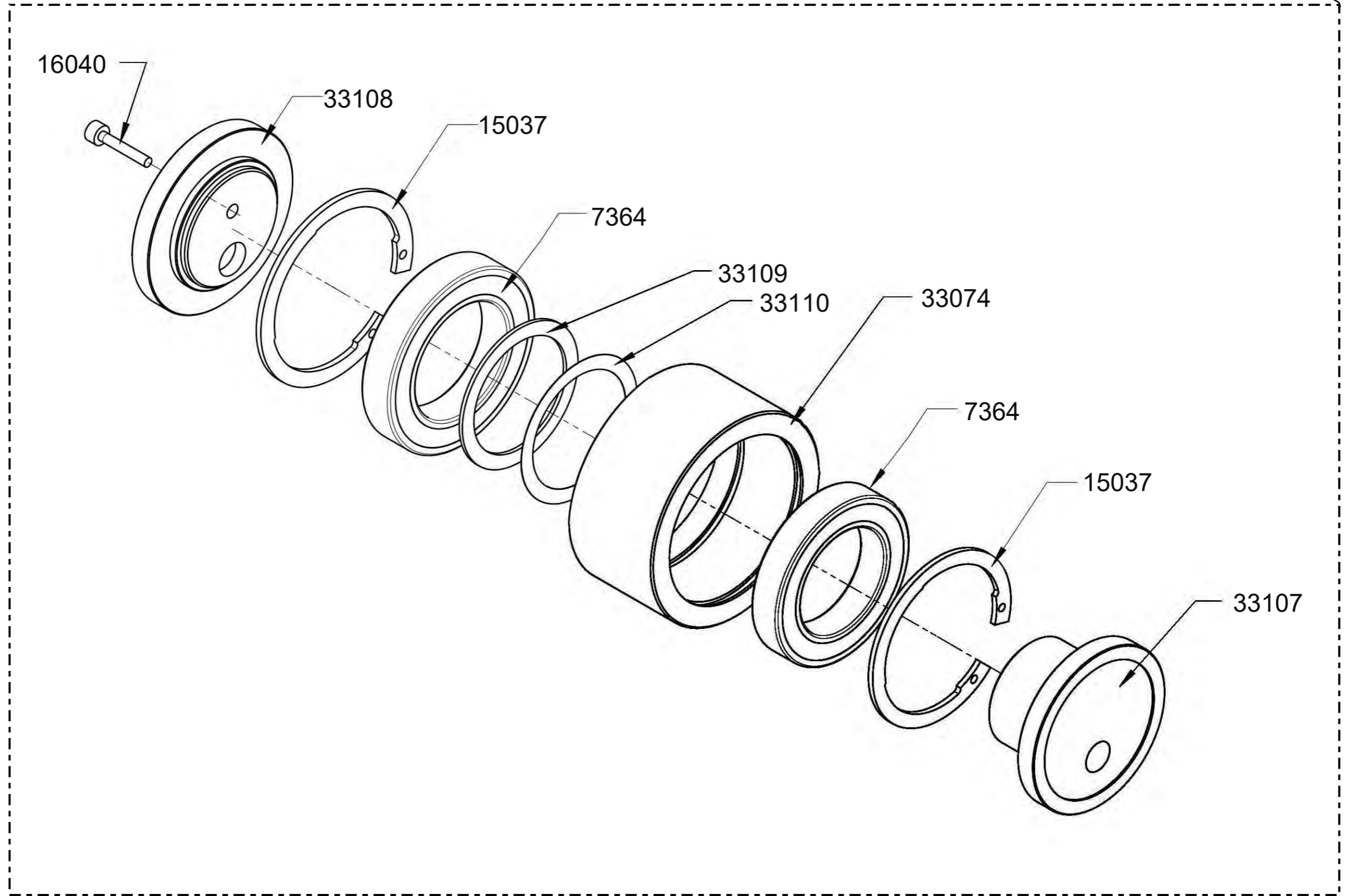

IIM

tel (336) 584-4777
fax (336) 584-9540
sales@iimnc.com
www.iimnc.com

Section 6: Belt Tensioner

GKF3005 - revised 3/1/2022

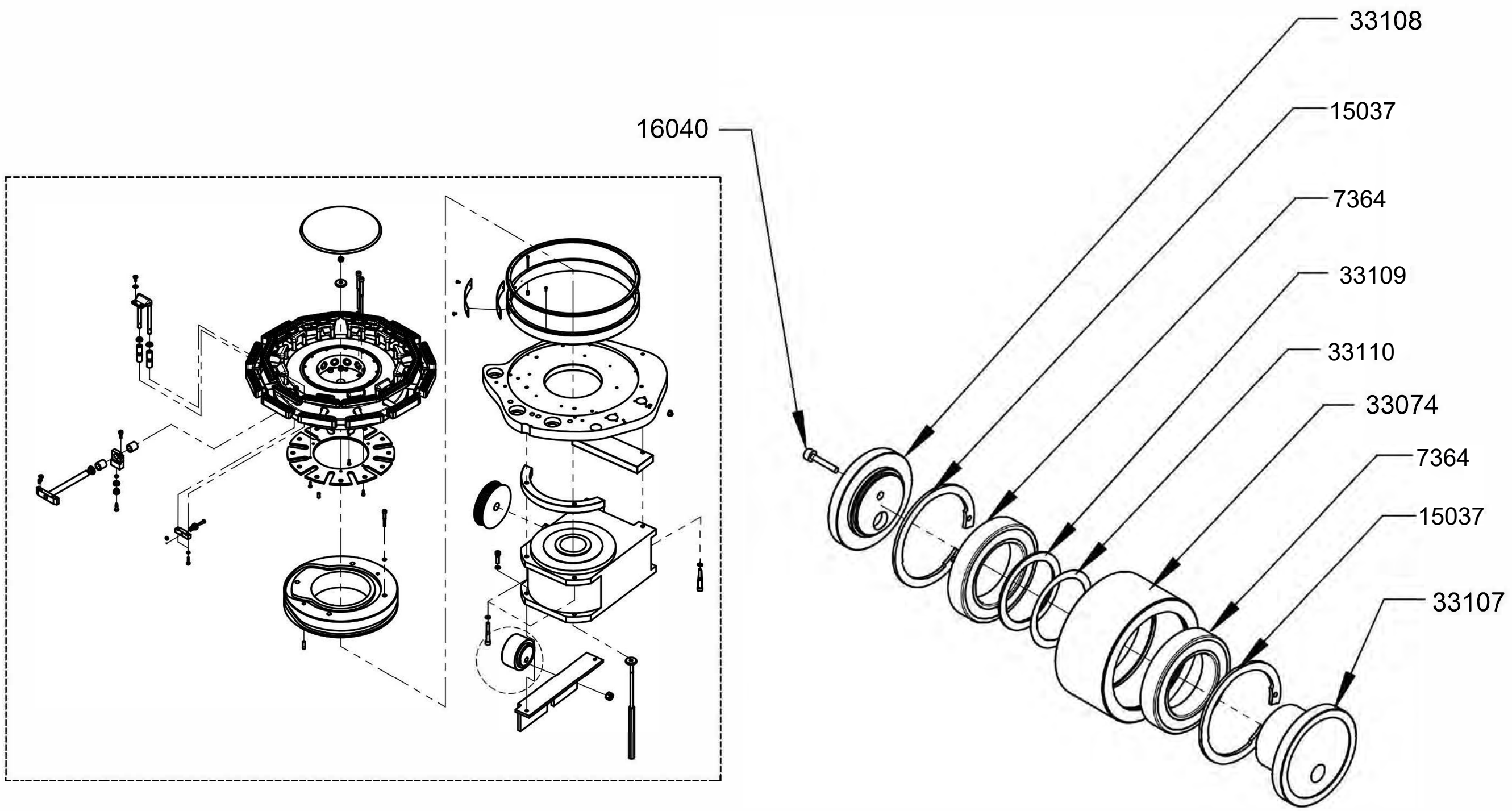

IIM
tel (336) 584-4777
fax (336) 584-9540
sales@iimnc.com
www.iimnc.com

Section 7: Segment Carriers / Turret / Gearbox

GKF3005 - revised 7/14/23

IIM Upgrade - (24x)34535

2 Pieces - (24x)32779

(24x)13675

(24x)14500

13857

(8x)13898

(8x)13876

33362

33123

33121

7959

(2x)33116

(6x)33118

(6x) 33111

(18x)13142

14452

33119

33120

33120

33120

13728

13671

(3x)33115

13485

(2x)33113

(4x)13877

(2x)33112

(2x)13877

(2x)33112

13780

13857

14315

(12x) Detail H

H

13494

(2x)13938

13672

(2x)14501

(2x)9289

13680

29405

(2x)13777

(2x)3379

13678

J

33114

(12x) Detail J

13667

13771

13677

13795

(2x)13861

(2x)3734

(2x)7937

IIM
tel (336) 584-4777
fax (336) 584-9540
sales@iimnc.com
www.iimnc.com

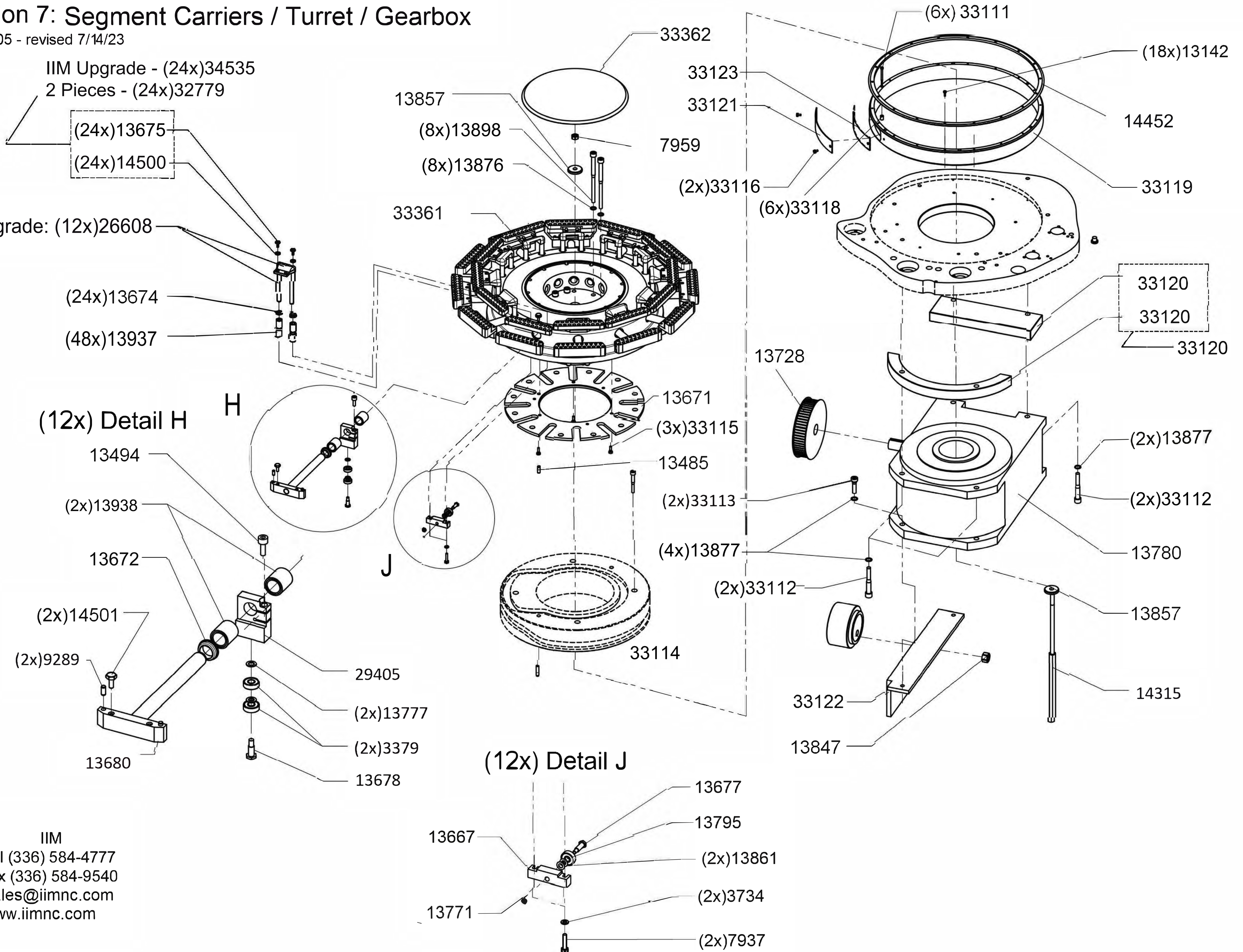

Section 8: Sorting Drive

GKF3005 - revised 3/1/2022

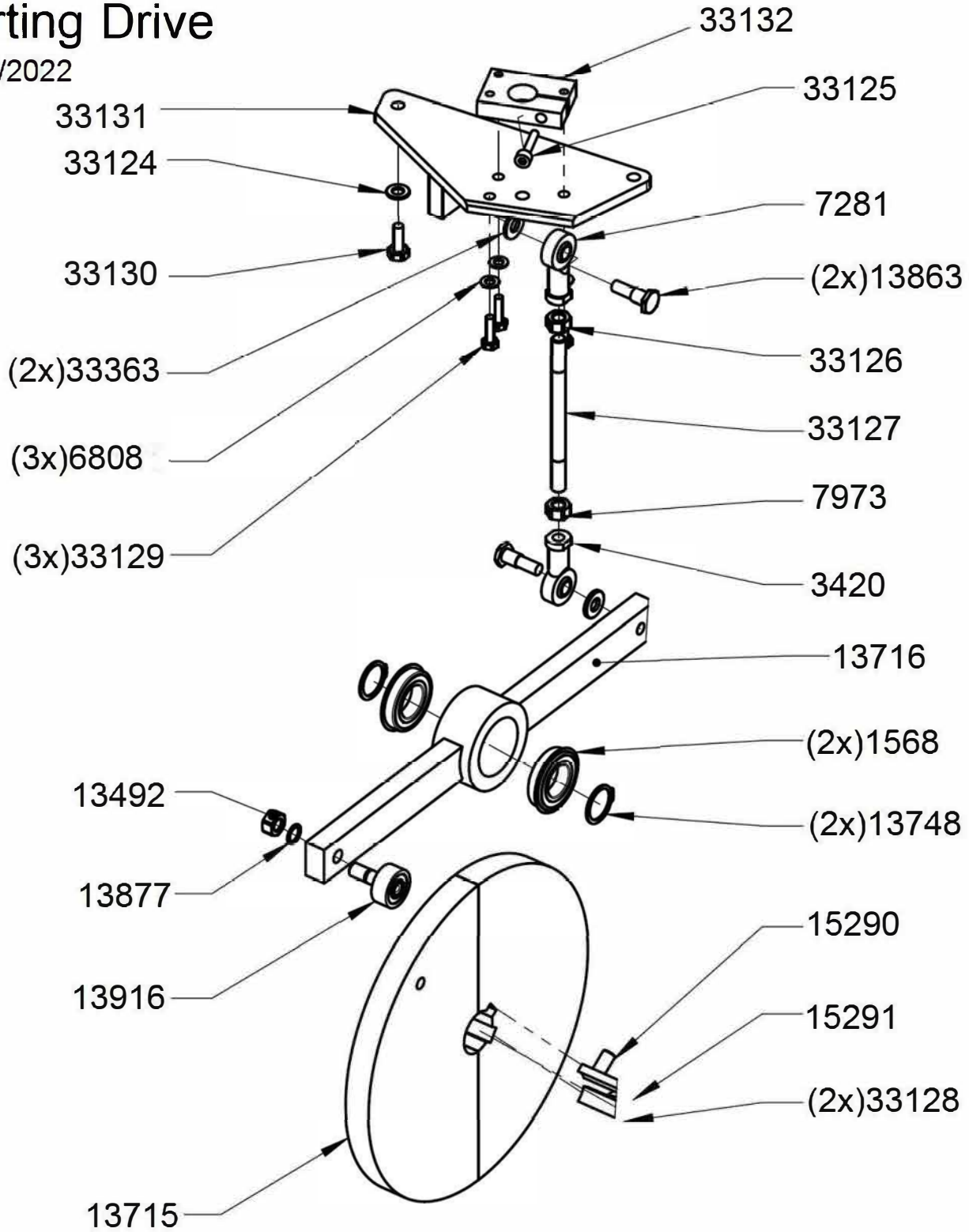

IIM
tel (336) 584-4777
fax (336) 584-9540
sales@iimnc.com
www.iimnc.com

Section 9: Separation Drive

GKF3005 - revised 3/1/2022

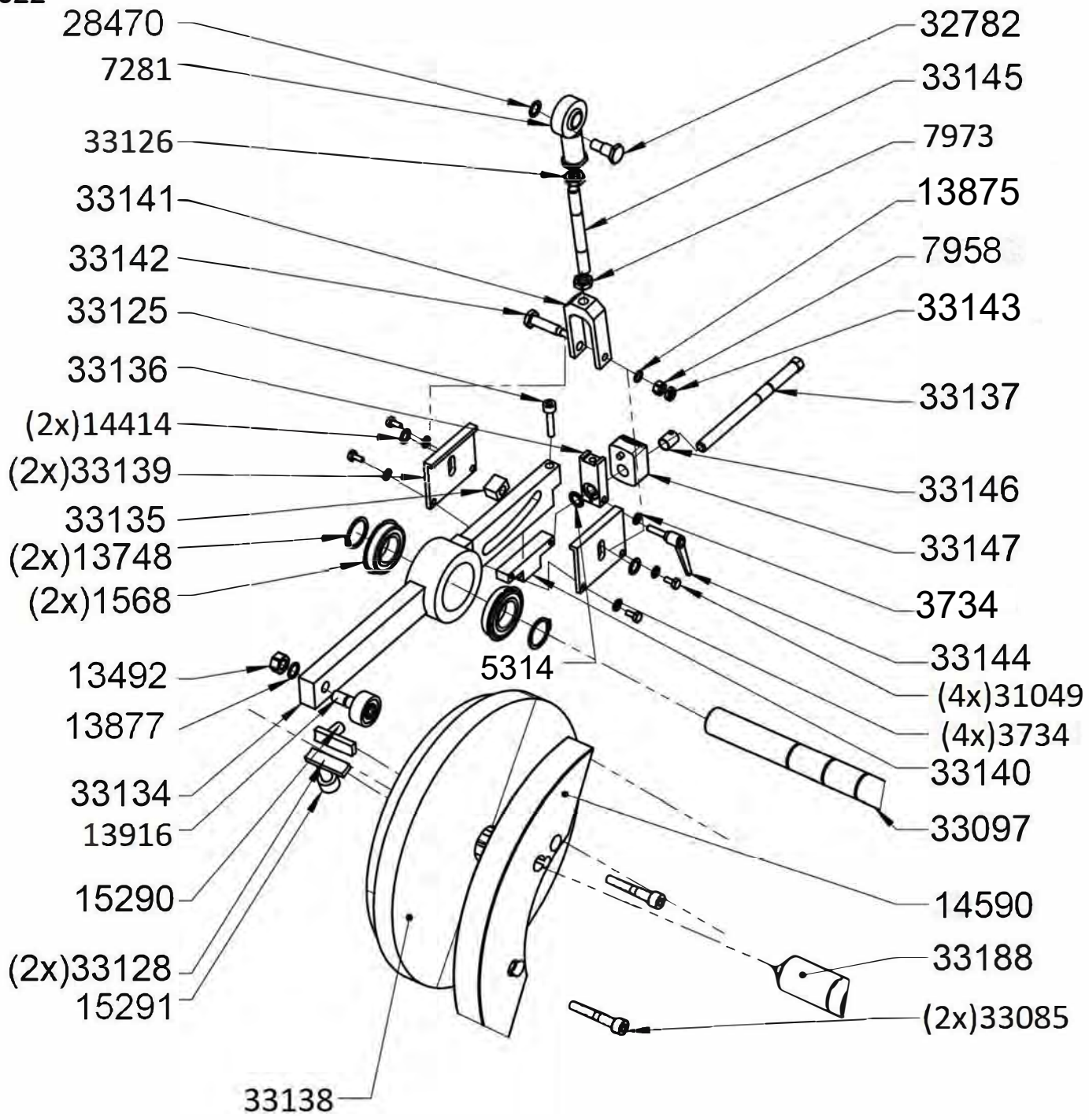

IIM
tel (336) 584-4777
fax (336) 584-9540
sales@iimnc.com
www.iimnc.com

Section 10: Tamping Station

GKF3005 - revised 3/1/2022

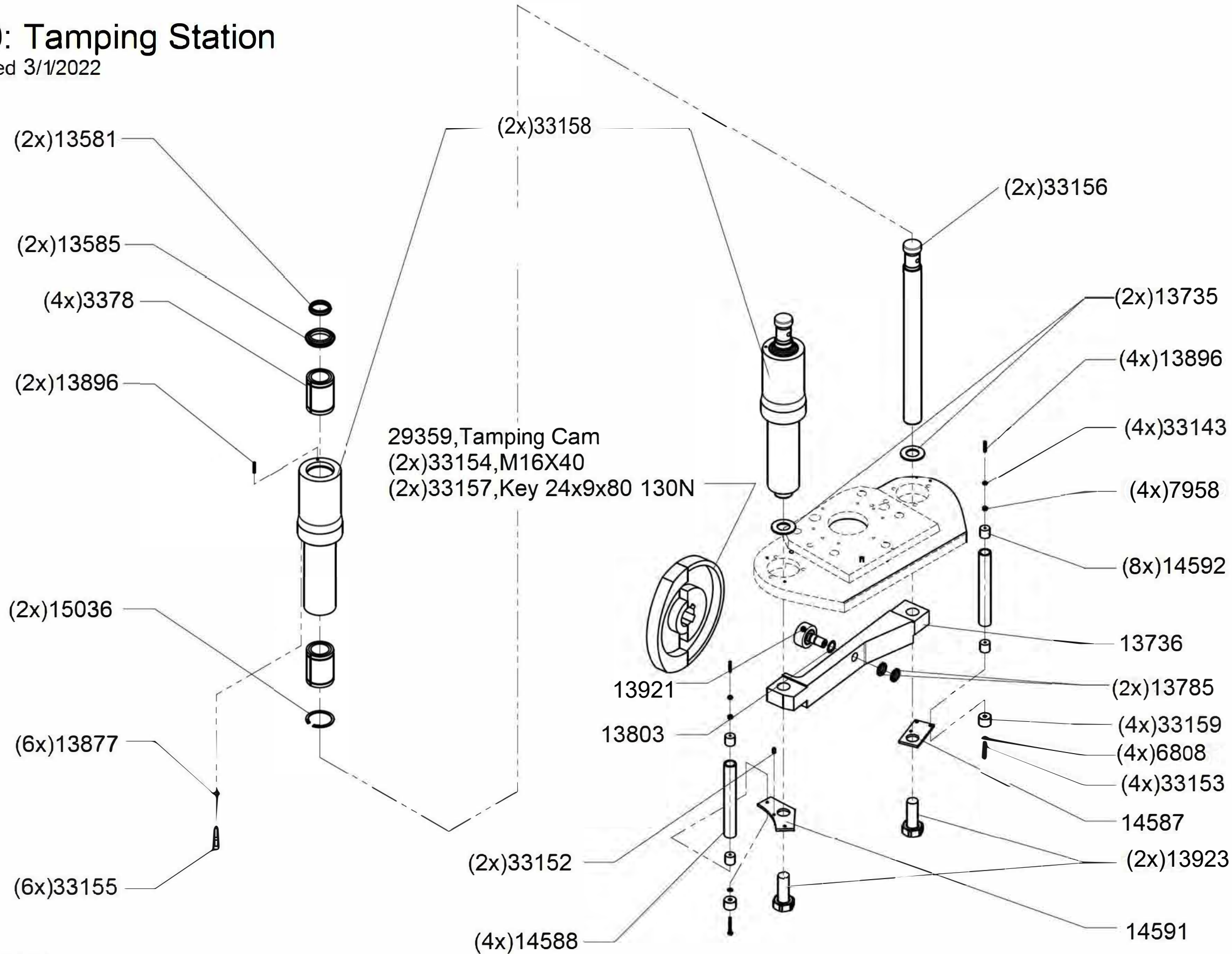

IIM
tel (336) 584-4777
fax (336) 584-9540
sales@iimnc.com
www.iimnc.com

Section 11: Dosing Station and Gearbox

GKF3005 - revised 3/12/2022

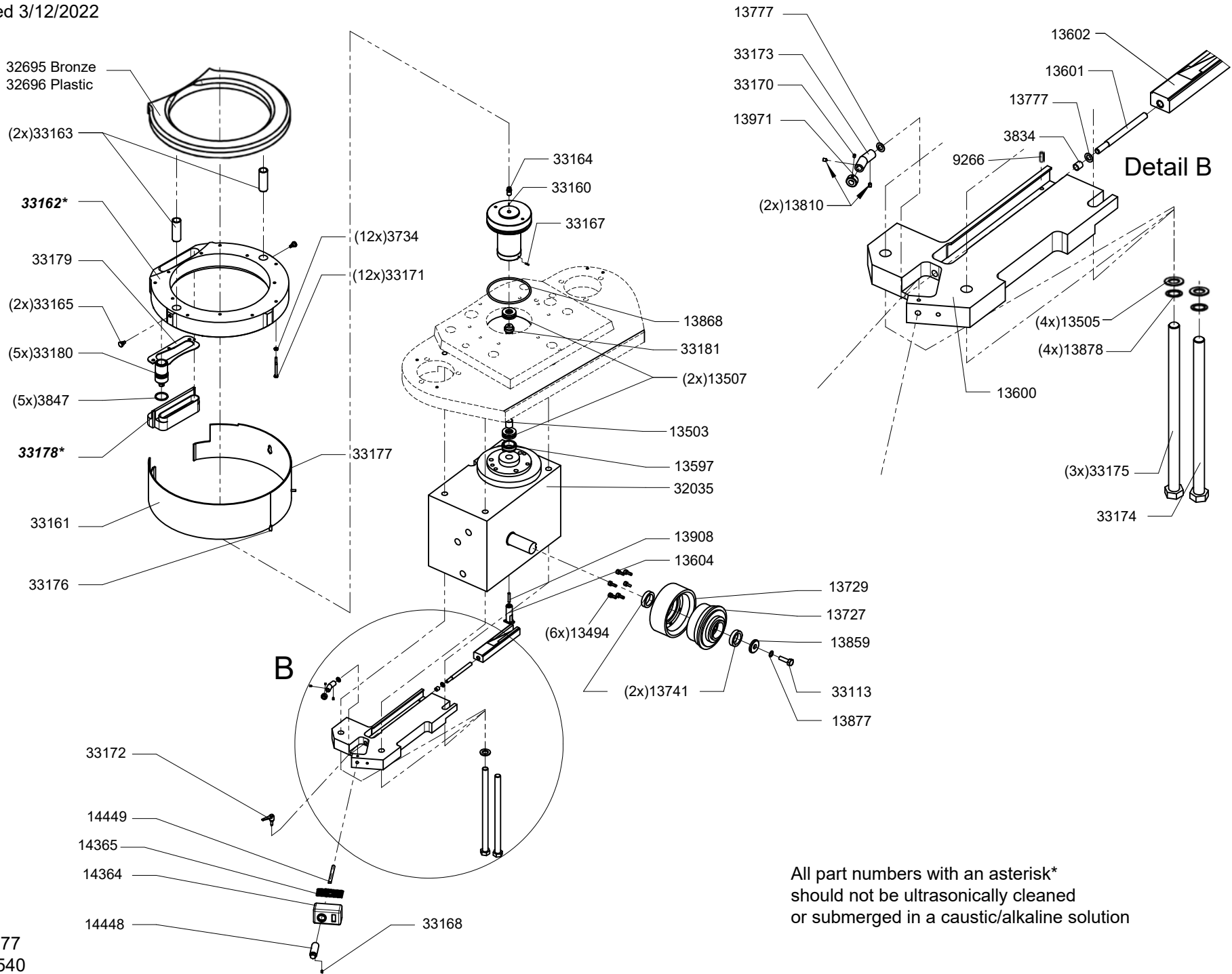

All part numbers with an asterisk* should not be ultrasonically cleaned or submerged in a caustic/alkaline solution

IIM
 tel (336)584-4777
 fax (336)584-9540
 sales@iimnc.com
 www.iimnc.com

Section 12: Powder Motor & Gearbox

GKF3005 - revised 3/2/2022

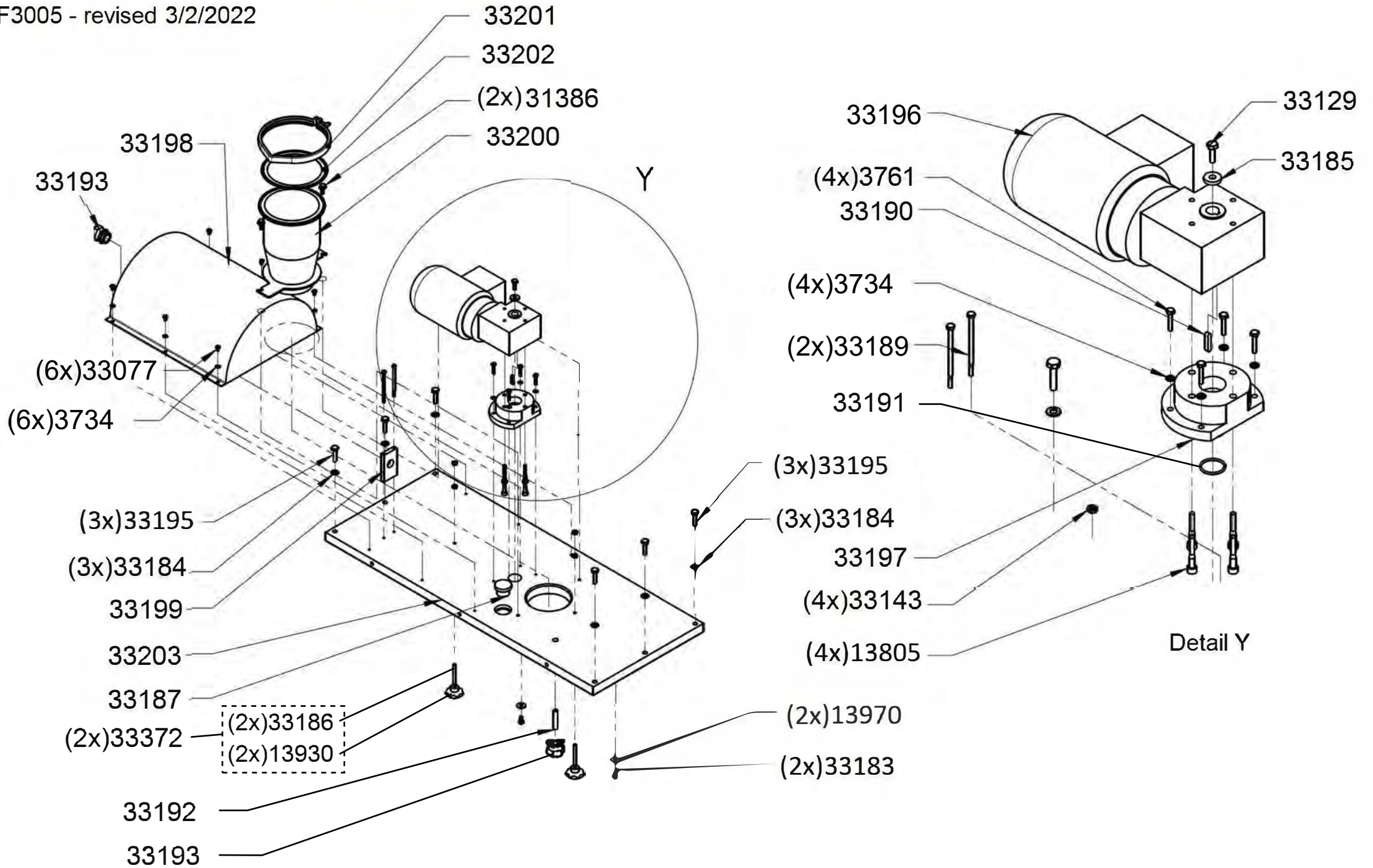

IIM

tel (336) 584-4777

fax (336) 584-9540

sales@iimnc.com

www.iimnc.com

Section 13: Powder Auger & Hopper

GKF3005 - revised 2/20/2023

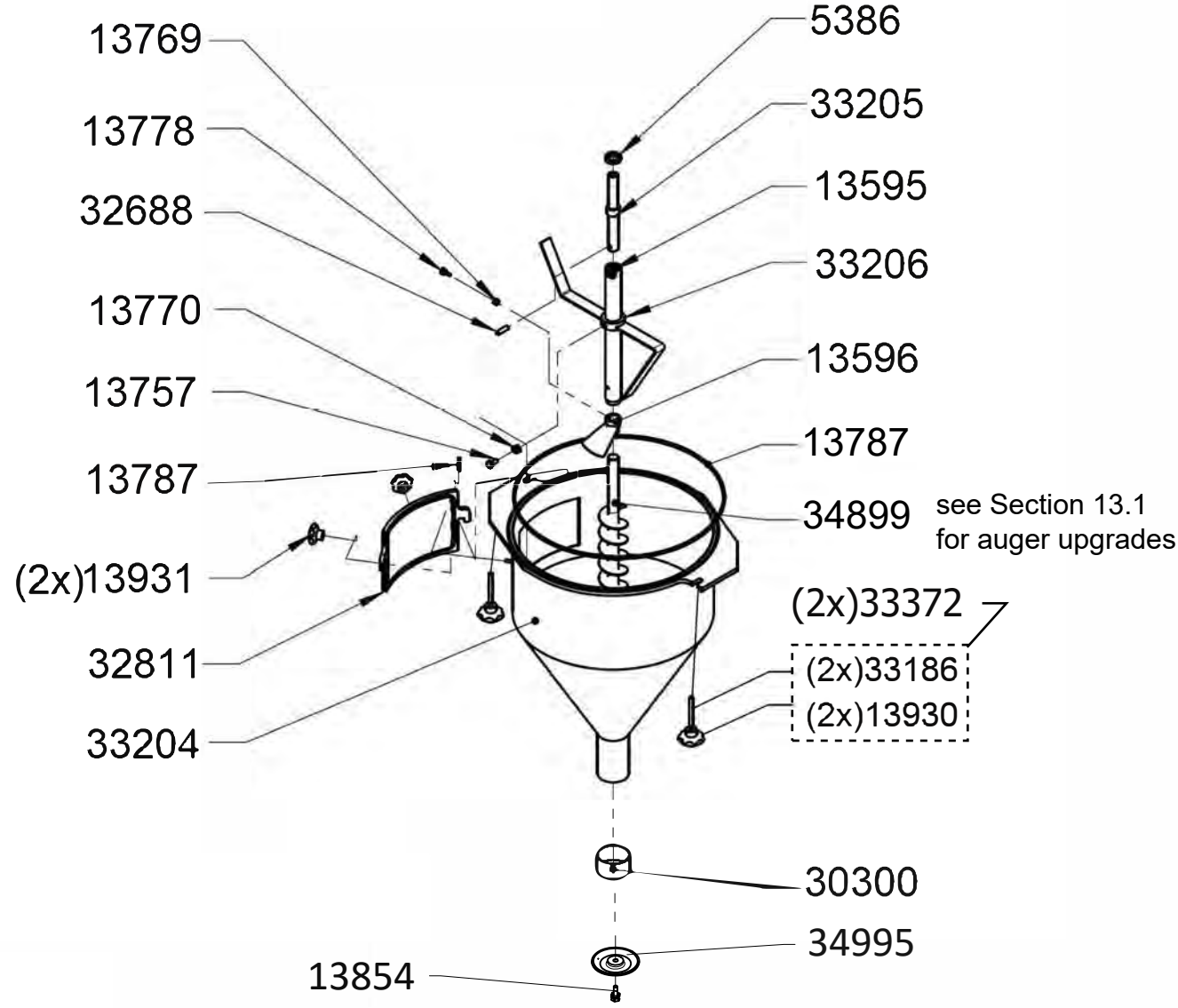

IIM
tel (336) 584-4777
fax (336) 584-9540
sales@iimnc.com
www.iimnc.com

Section 13.1: Auger Upgrades

GKF3005 – revised 7/7/2023



34900
¼ TWIST
152 PITCH



34996
3 TWIST
61.25 PITCH

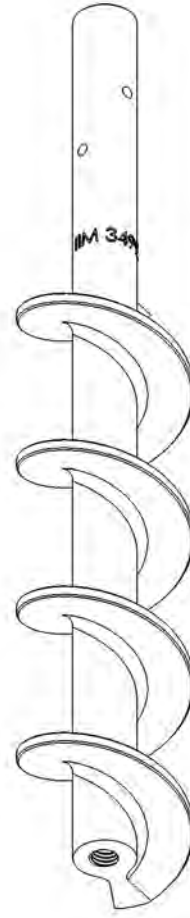

34997
4 TWIST
46 PITCH

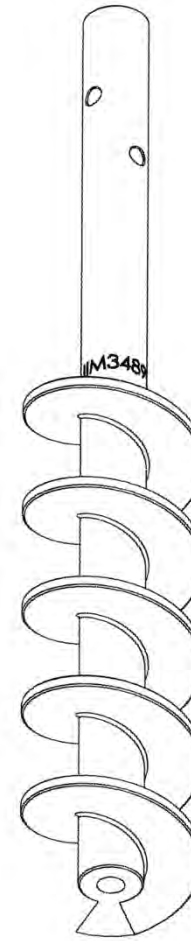

34899
5 TWIST
37 PITCH



34471
8 TWIST
23 PITCH

IIM

tel (336)584-4777

fax (336)584-9540

sales@iimnc.com

www.iimnc.com

Section 14: Ejection Drive - New Version - 3 Shaft

New Version > 2017

GKF3005 - revised 7/14/23

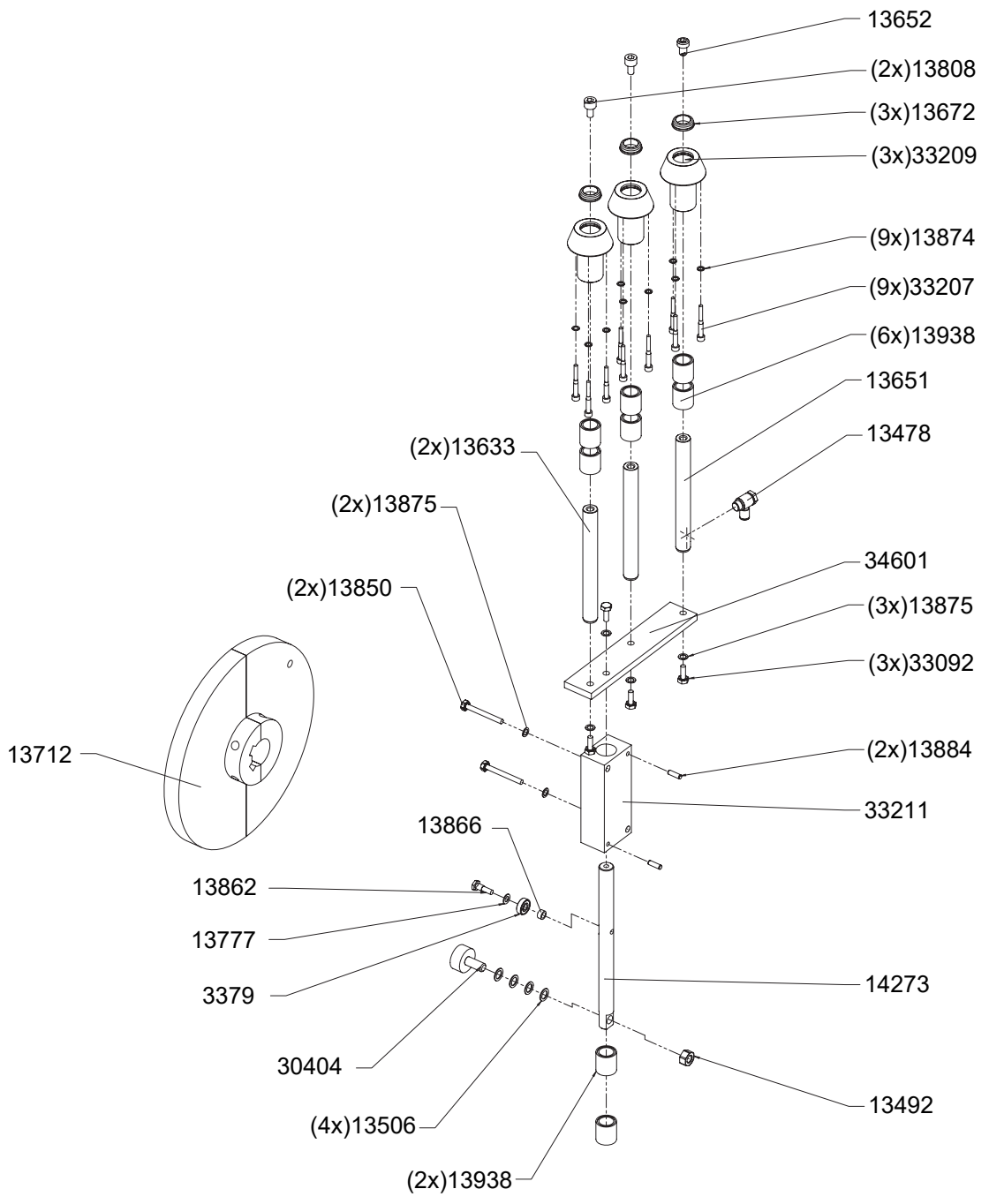

IIM
tel (336) 584-4777
fax (336) 584-9540
sales@iimnc.com
www.iimnc.com

Section 14.1: Ejection Drive - Old Version - 2 Shaft

Old Version 2014-2017
GKF3005 - revised 7/14/23

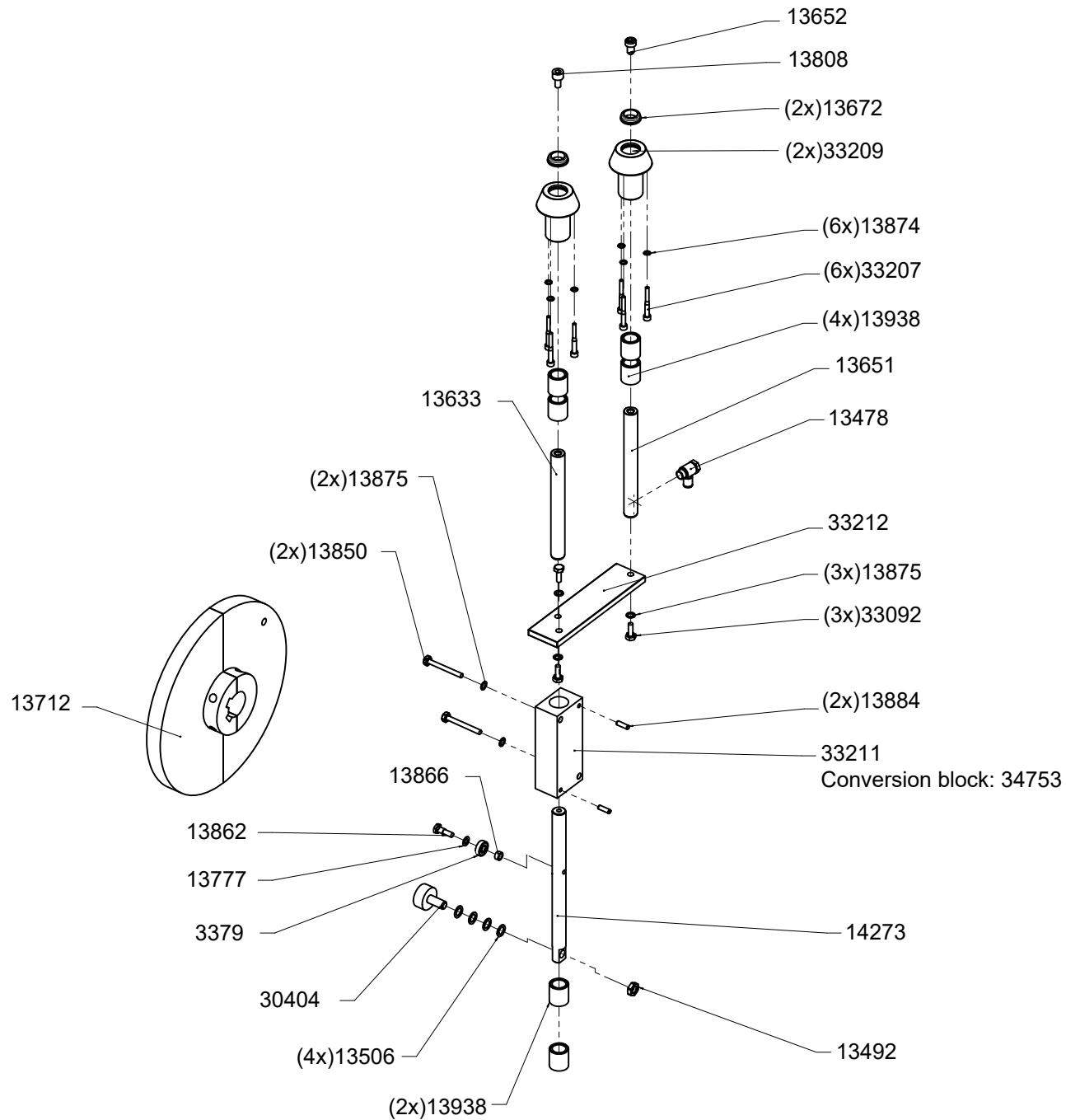

IIM
tel (336) 584-4777
fax (336) 584-9540
sales@iimnc.com
www.iimnc.com

Section 14.2: Ejection Drive - Old Version - 2 Shaft - Cantilever Cam Follower

Old Version < 2014
GKF3005 - revised 7/14/23

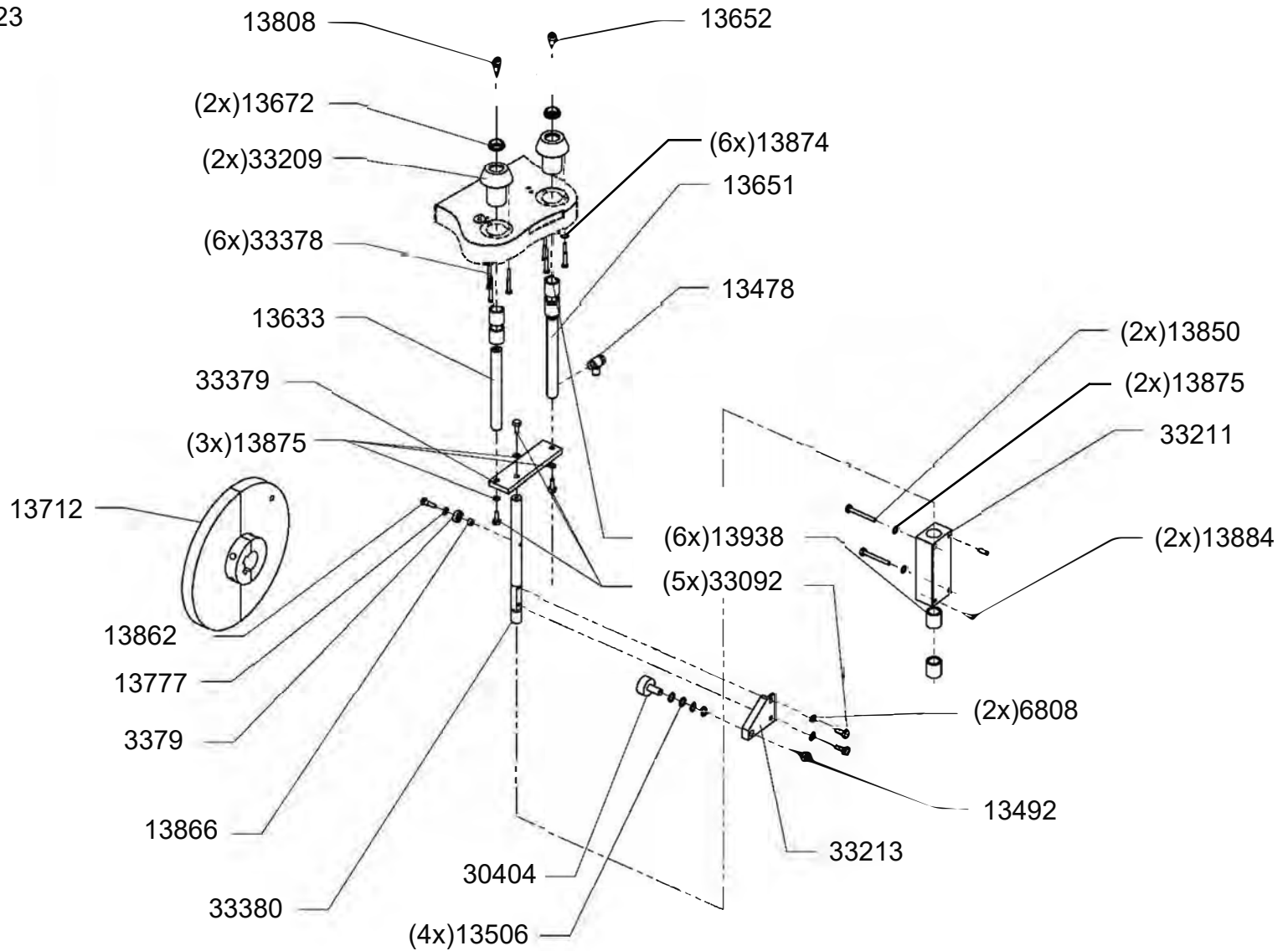

IIM

tel (336)584-4777

fax (336)584-9540

sales@iimnc.com

www.iimnc.com

Section 15: Dosing Base with Disc

GKF3005 revised 3/2/2022

IIM#	Bolt Length
(6x)31280	26mm
(6x)32804	30mm
(6x)32041	32mm
(6x)13819	35mm
(6x)31436	45mm

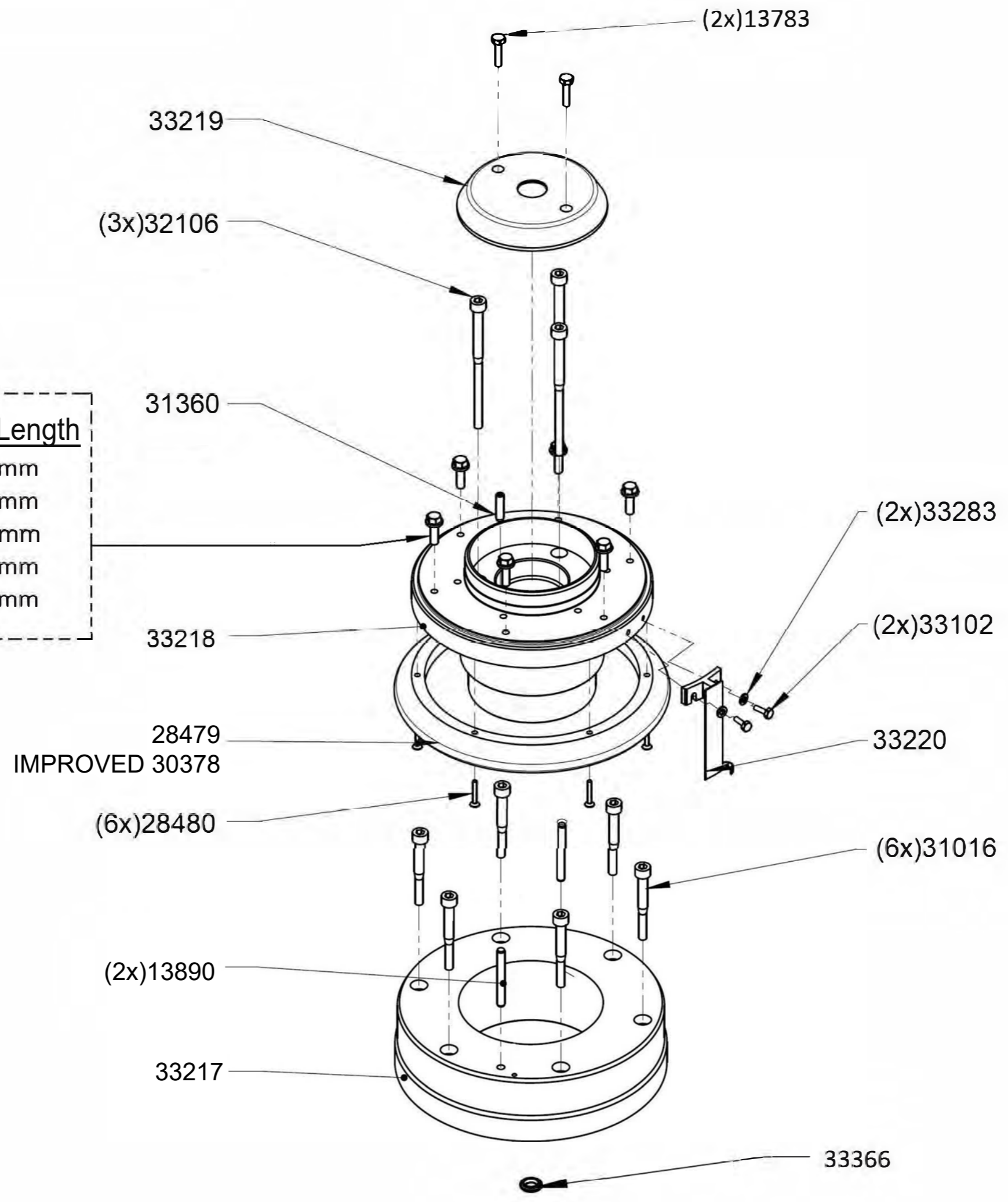

IIM
 tel (336) 584-4777
 fax (336) 584-9540
 sales@iimnc.com
 www.iimnc.com

Section 16: Powder Tamping Ring / Dosing Disc

GKF3005 - revised 7/2/2021

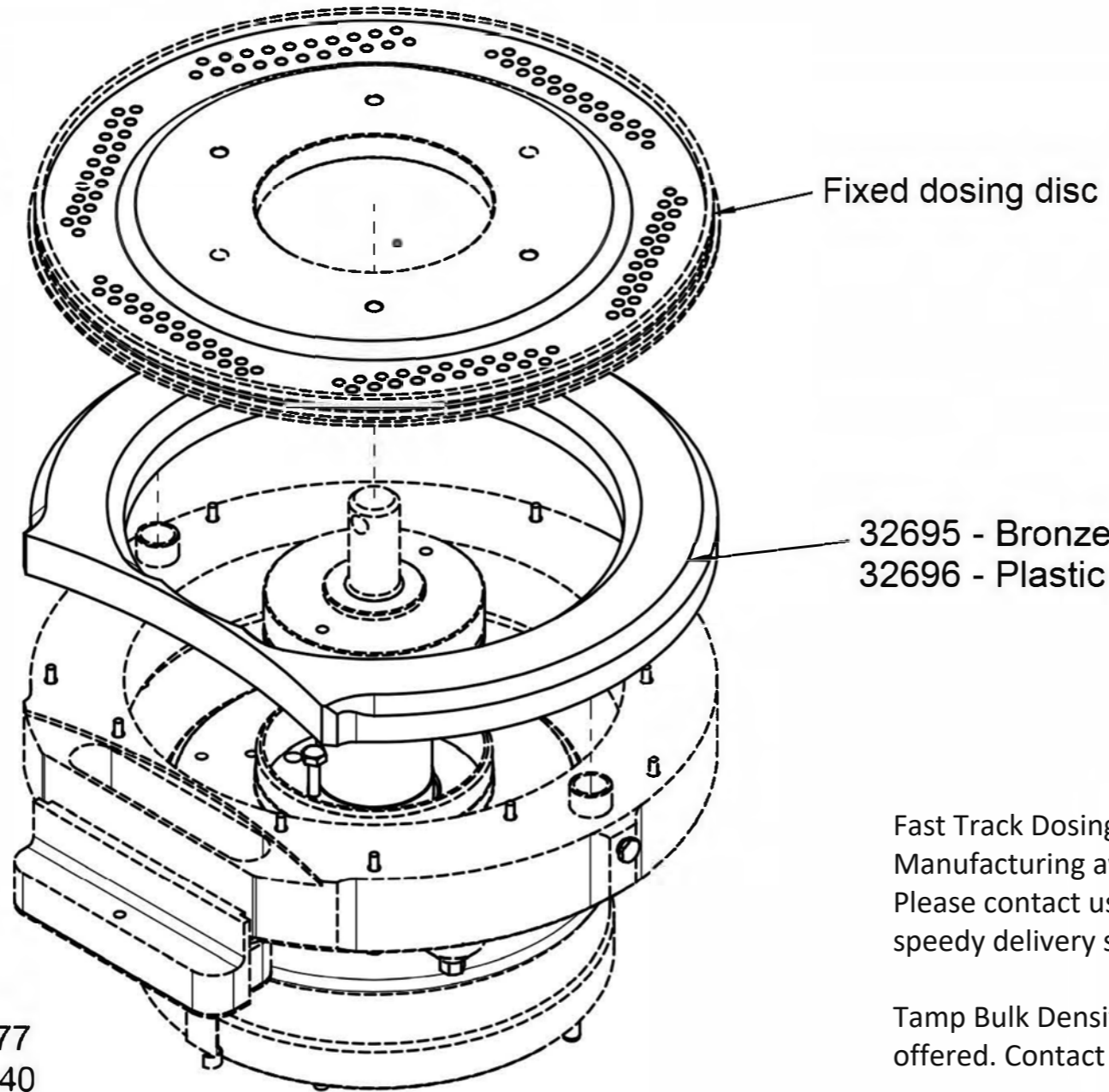

<u>IIM#</u>	<u>Description</u>
34016	Fixed Dosing Disc Size 000
34017	Fixed Dosing Disc Size 00
34018	Fixed Dosing Disc Size 0
34019	Fixed Dosing Disc Size 1
34020	Fixed Dosing Disc Size 2
34021	Fixed Dosing Disc Size 3
34022	Fixed Dosing Disc Size 4
contact us	Fixed Dosing Disc Size 5

Dosing Disc Storage Box
Fixed: IIM# 32165
Adjustable: IIM# 31281

Dosing Disc Bolts
(6x)31280 - M8x26
(6x)32041 - M8x32
(6x)13819 - M8x36

Fast Track Dosing Disc
Manufacturing available.
Please contact us for a
speedy delivery service.

Tamp Bulk Density Testing
offered. Contact us.

IIM
tel (336) 584-4777
fax (336) 584-9540
sales@iimnc.com
www.iimnc.com

Section 17: Size Change Parts 21CT

GKF3005 - revised 12/9/2022

Note: Fast Track Dosing Disc Manufacturing available.
Please contact us for speedy delivery service.

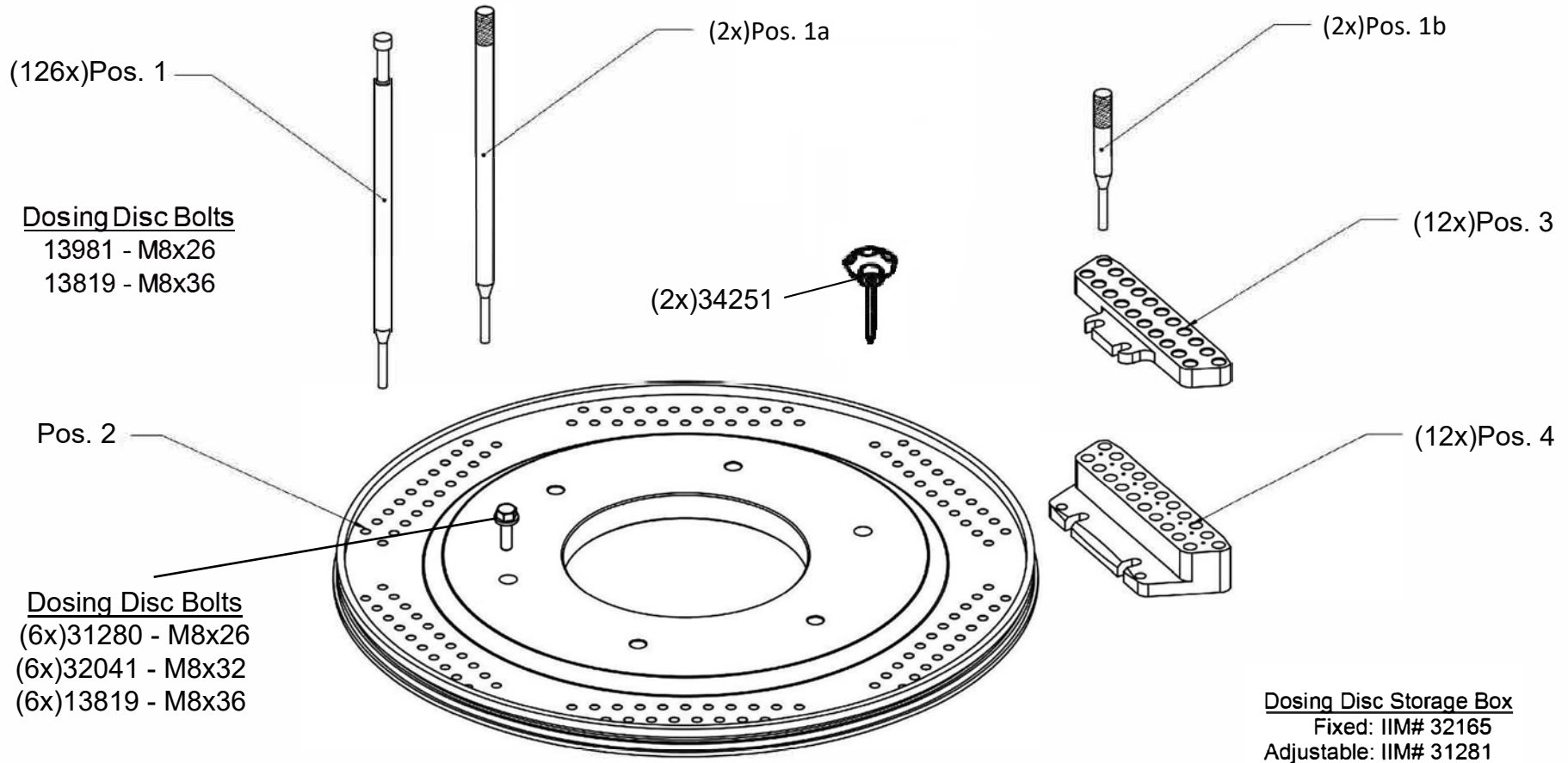

MIRRORED TAMPING PINS AVAILABLE

	<u>Description</u>	<u>Capsule Size</u>						
		000	00	0	1	2	3	4
Pos. 1	Tamping Pin	13065	13066	12953	13062	13067	13068	13069
Pos. 1a	Dosing Align Pin	7289	3539	7291	4925	5188	5189	7293
Pos. 1b	Segment Align Pin	13360	4923	8185	4924	5190	5191	13361
Pos. 2	Fix Dosing Disc	34016	34017	34018	34019	34020	34021	34022
Pos. 3	Upper Segment	33998	33999	34000	34001	34002	34003	34004
Pos. 4	Lower Segment	34005	34006	34007	34008	34009	34010	34011

IIM
tel (336) 584-4777
fax (336) 584-9540
sales@iimnc.com
www.iimnc.com

Section 18: Size Change Parts 10CT

GKF3005 - revised 3/2/2022

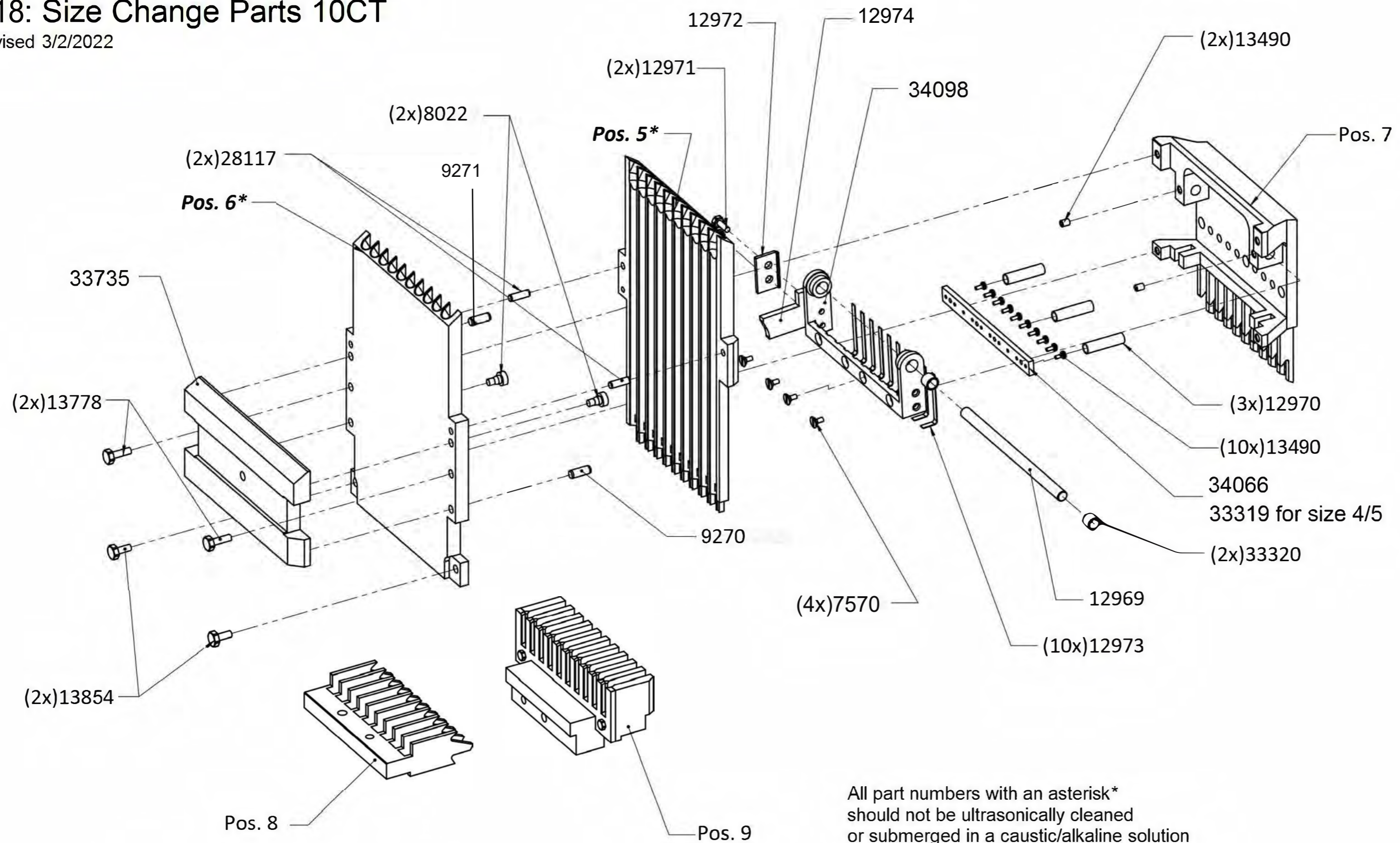

Note: Custom Parts or Specialty Parts available on request.
Storage Boxes available.

All part numbers with an asterisk* should not be ultrasonically cleaned or submerged in a caustic/alkaline solution

IIM
tel (336) 584-4777
fax (336) 584-9540
sales@iimnc.com
www.iimnc.com

		Capsule Size						
	Description	000/000eI	00/00eI	0/0eI	1/1eI	2/2eI	3	4/4eI
Pos. 5*	Magazine	34044	34045	34046	34051	34052	34053	34054
Pos. 6*								
Pos. 7	Vertical Fingers	34038	34037	34039	34040	34041	34042	34043
Pos. 8	Orientation Fingers	34023	34025	34024	34026	34027	34028	34029
Pos. 9	Sorting Block	34030	34031	34032	34033	34034	34035	34036

Section 19: Size Change Parts 11CT

GKF3005 - revised 3/2/2022

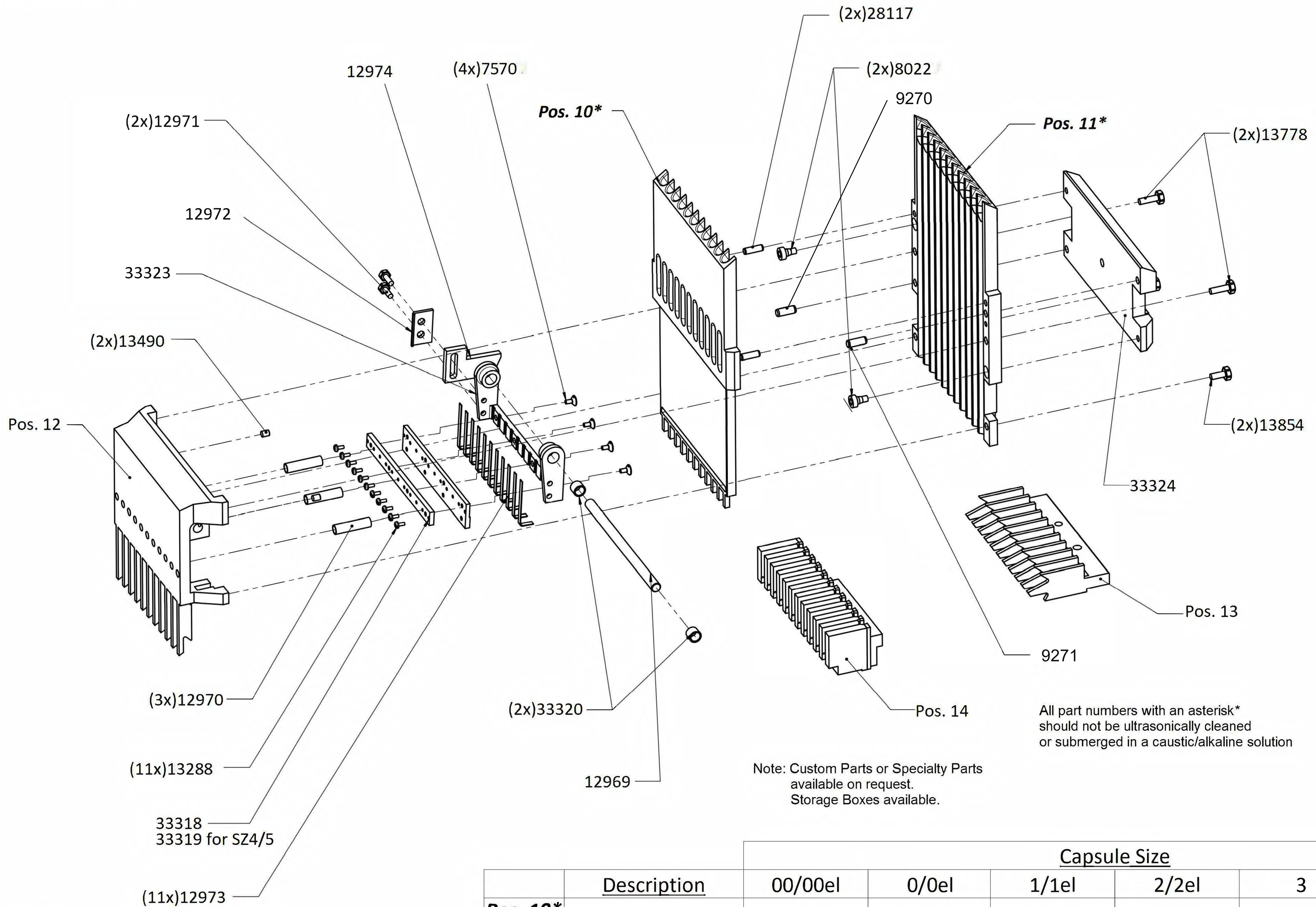

All part numbers with an asterisk* should not be ultrasonically cleaned or submerged in a caustic/alkaline solution

Note: Custom Parts or Specialty Parts available on request. Storage Boxes available.

		Capsule Size					
	Description	00/00el	0/0el	1/1el	2/2el	3	4/4el
Pos. 10*	Magazine	33042	33041	33040	33039	33038	33037
Pos. 11*							
Pos. 12	Vertical Fingers	33043	33044	33045	33046	33047	33048
Pos. 13	Orientation Fingers	33049	33050	33051	33052	33053	33054
Pos. 14	Sorting Block	33055	33056	33057	33058	33059	33060

Section 20: Segment Cam

GKF3005 - revised 3/2/2022

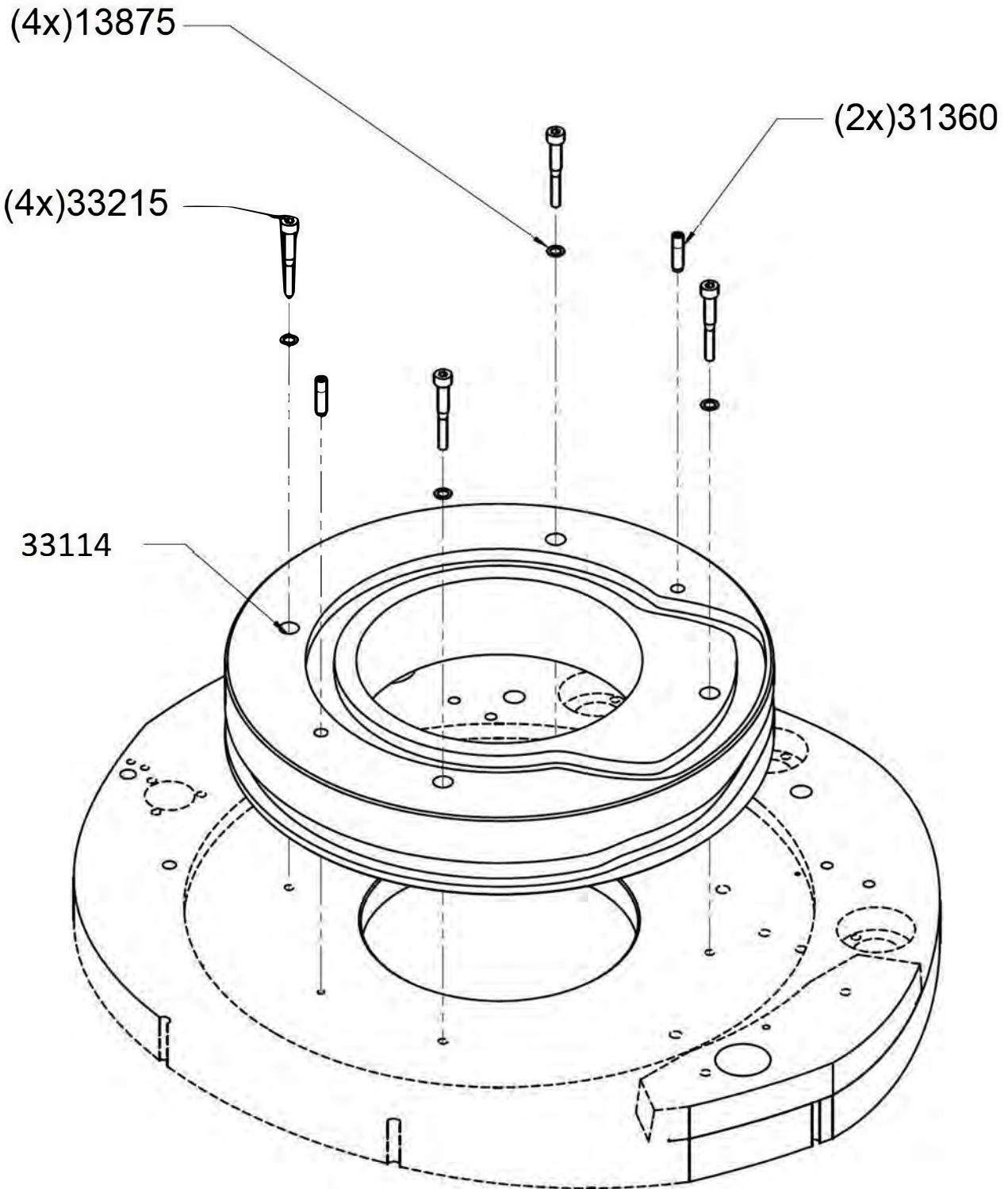

IIM
tel (336) 584-4777
fax (336) 584-9540
sales@iimnc.com
www.iimnc.com

Section 22: Closing Pins

GKF3005 - revised 3/2/2022

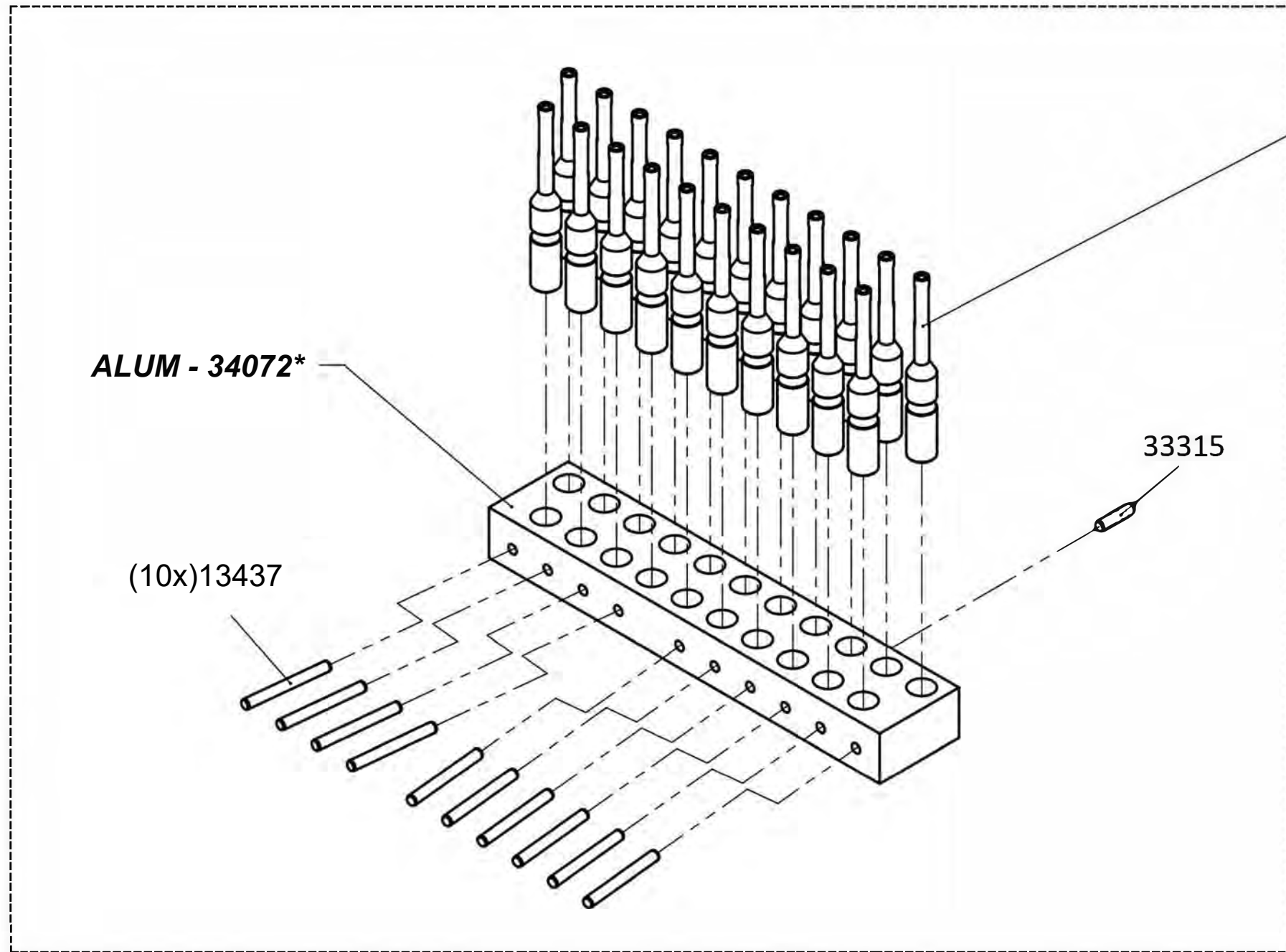

Lower Closing Pins

Capsule Size	IIM# Material: Stainless Steel	IIM# Material: Aluminum	IIM# Material: Stainless Steel		
000	ON REQUEST	ON REQUEST	29580		
00	16228	28121			
0			16230	32634	29581
1	16232	32635			33316
2					
3	ON REQUEST	ON REQUEST			
4					
5					

IIM SST Upgrade

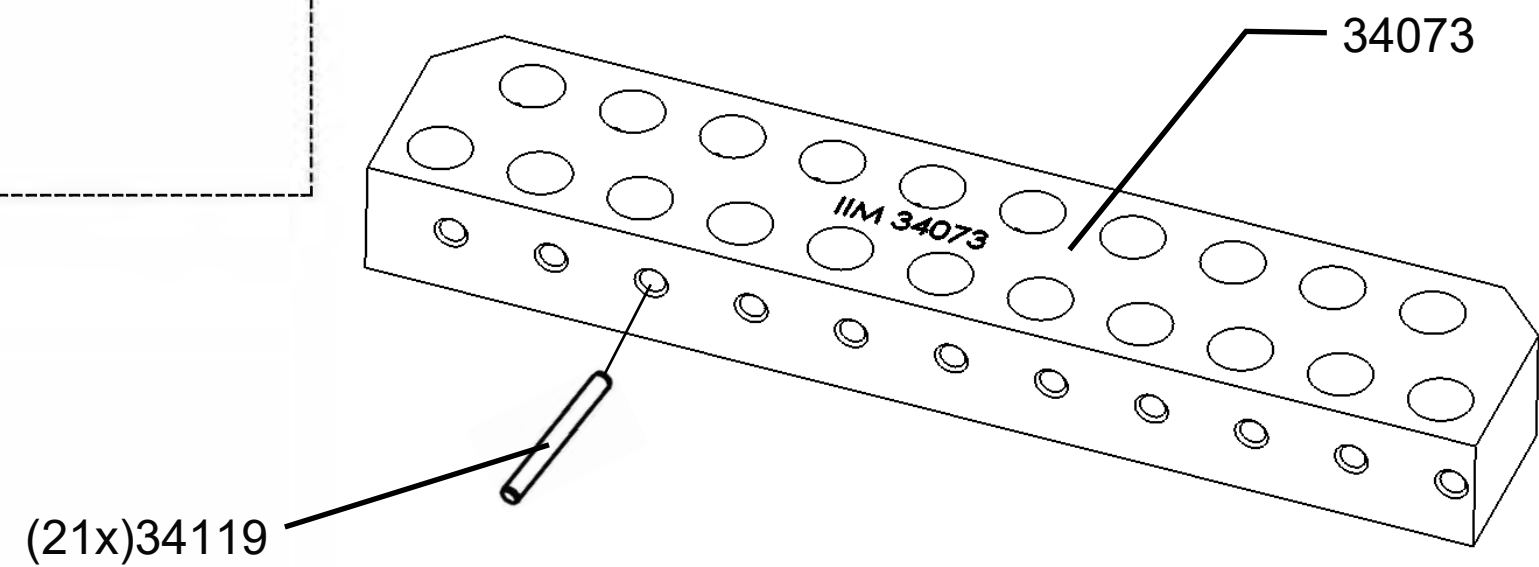

All part numbers with an asterisk* should not be ultrasonically cleaned or submerged in a caustic/alkaline solution

Section 23: Vacuum Station

GKF3005 - revised 3/2/2022

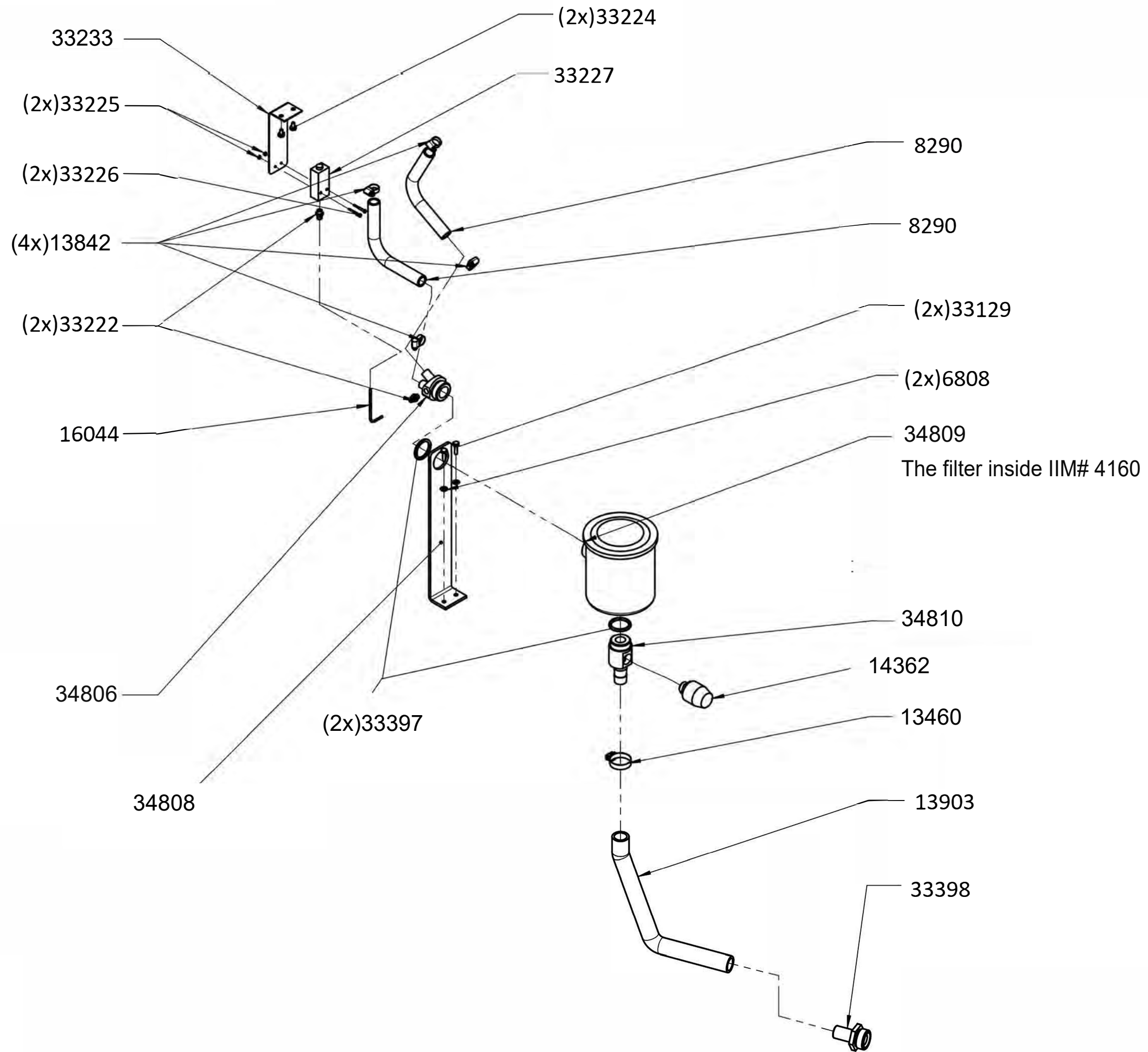

IIM

tel (336) 584-4777

fax (336) 584-9540

sales@iimnc.com

www.iimnc.com

Section 24: Capsule Sorting Housing & Drive - 11CT

GKF3005 - revised 7/14/23

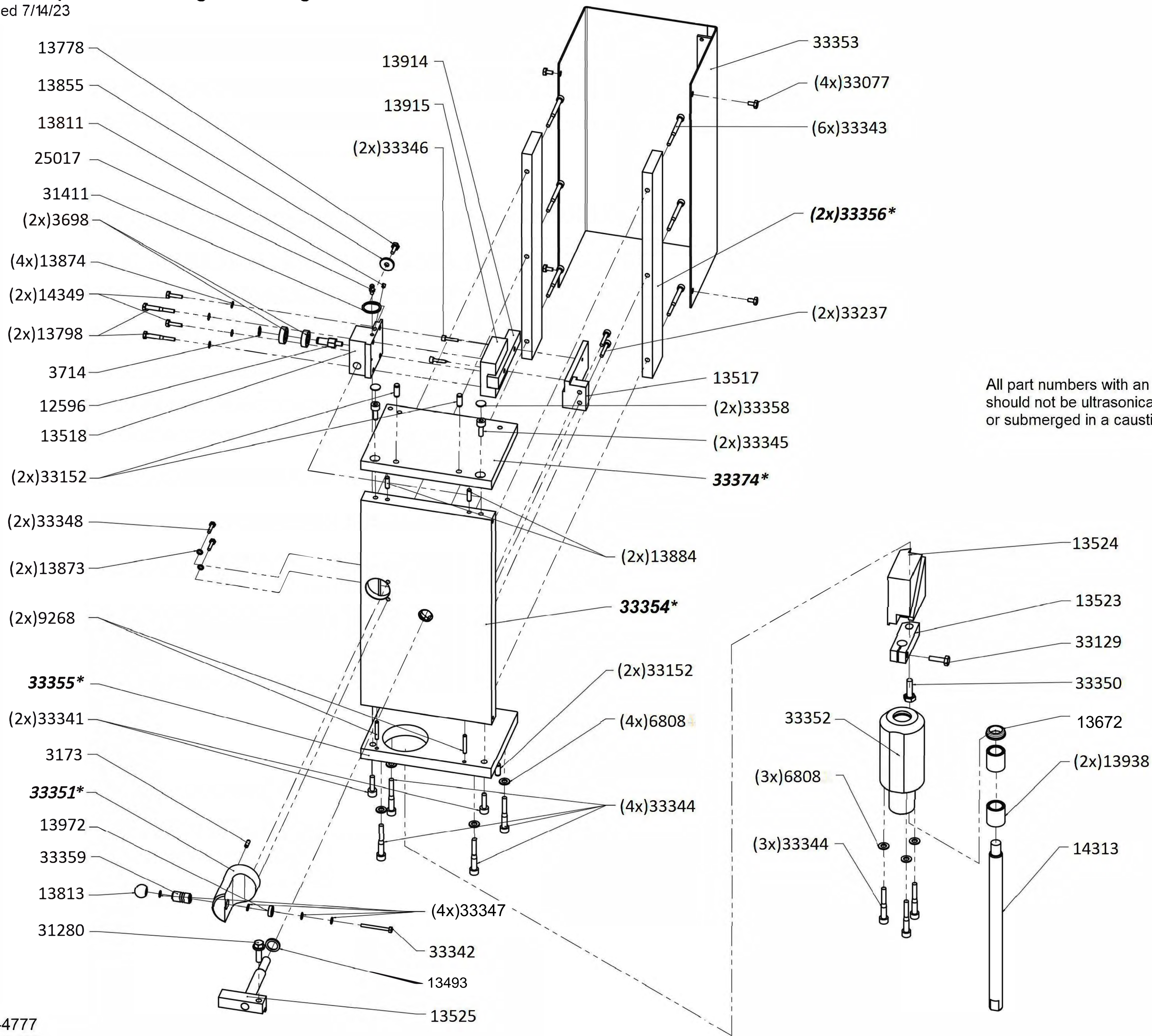

All part numbers with an asterisk* should not be ultrasonically cleaned or submerged in a caustic/alkaline solution

Capsule Orientation & Separation Station

GKF3005 - revised 3/2/2022

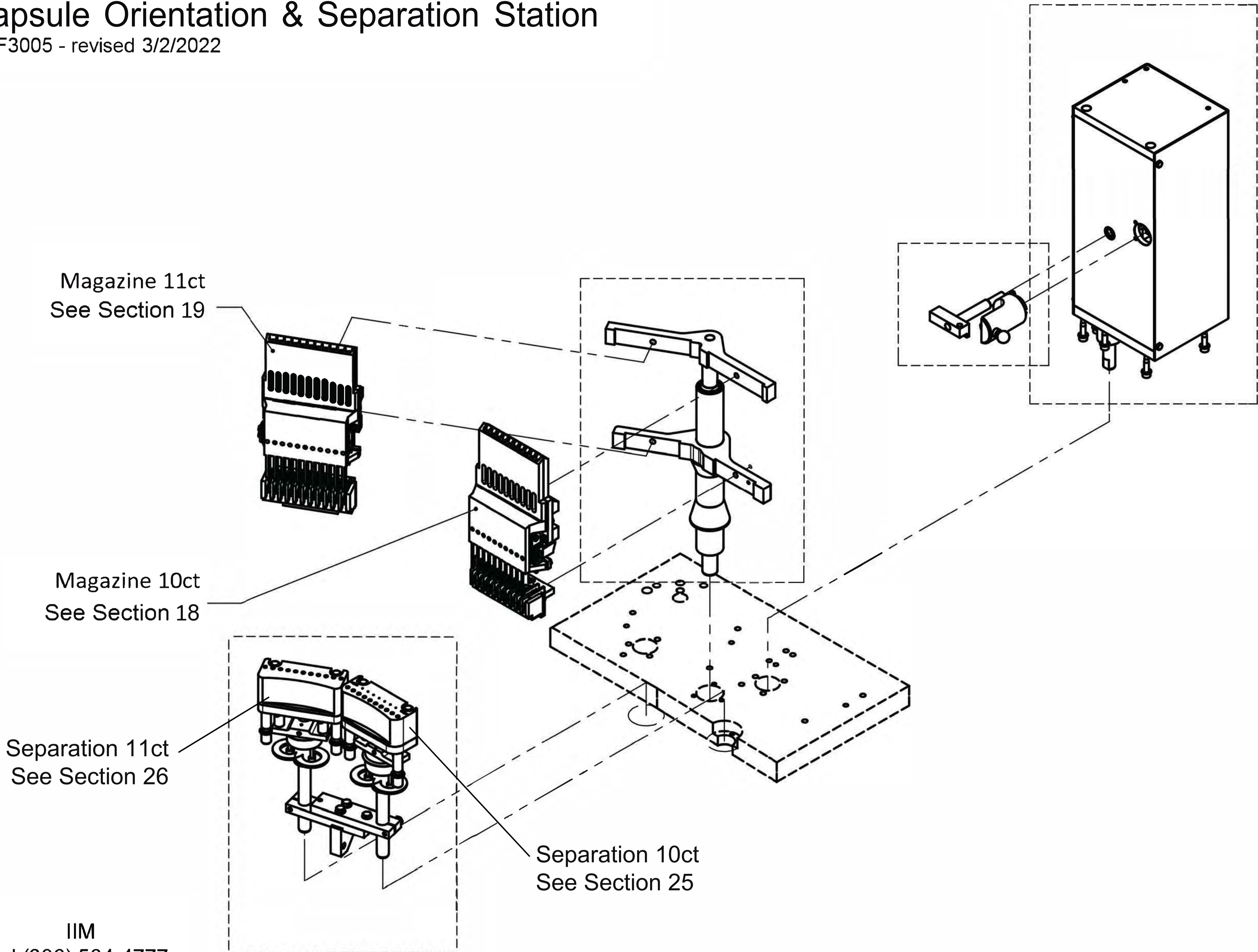

IIM
tel (336) 584-4777
fax (336) 584-9540
sales@iimnc.com
www.iimnc.com

Section 25: Capsule Separation Station - 10CT

GKF3005 - revised 7/14/23

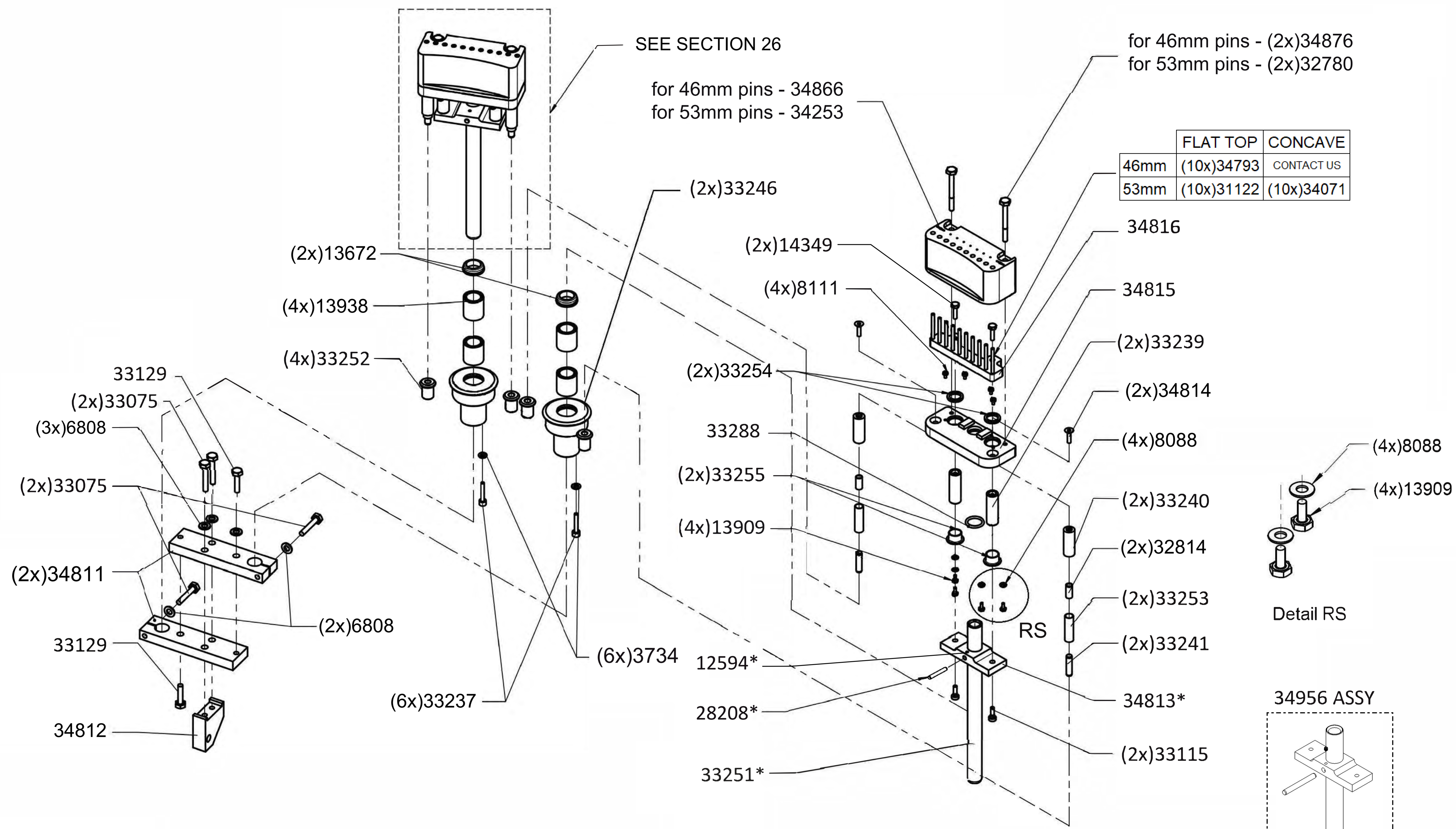

	FLAT TOP	CONCAVE
46mm	(10x)34793	CONTACT US
53mm	(10x)31122	(10x)34071

Detail RS

34956 ASSY

part numbers with an asterisk* are included in this assembly

IIM
 tel (336) 584-4777
 fax (336) 584-9540
 sales@iimnc.com
 www.iimnc.com

Section 26: Capsule Separation Station - 11CT

GKF3005 - revised 7/14/23

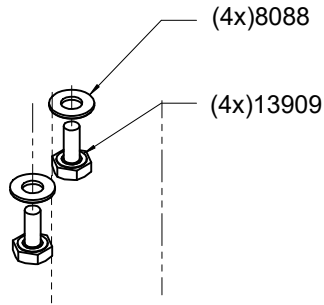

DETAIL W
SCALE 1:1

	FLAT TOP	CONCAVE
46mm	(11x)34793	CONTACT US
53mm	(11x)31122	(11x)34071

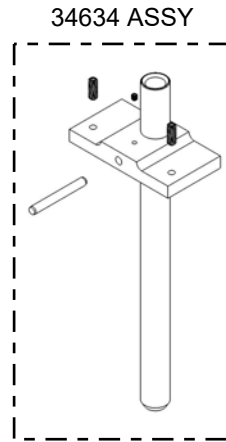

parts numbers with an asterisk* are included in this assembly

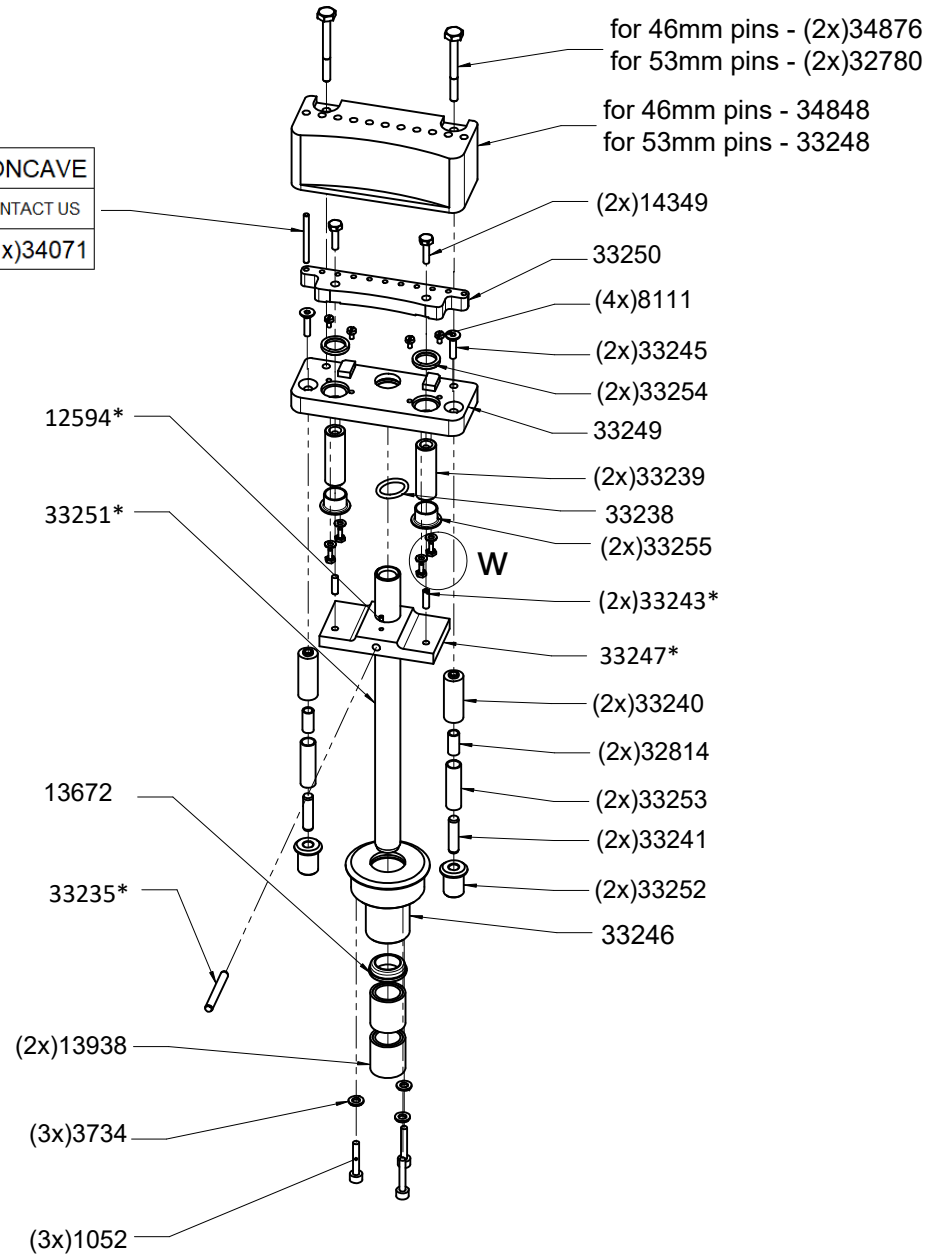

IIM

tel (336) 584-4777
 fax (336) 584-9540
 sales@iimnc.com
 www.iimnc.com

Section 27: Capsule Magazine Mounts

GKF3005 - revised 3/2/2022

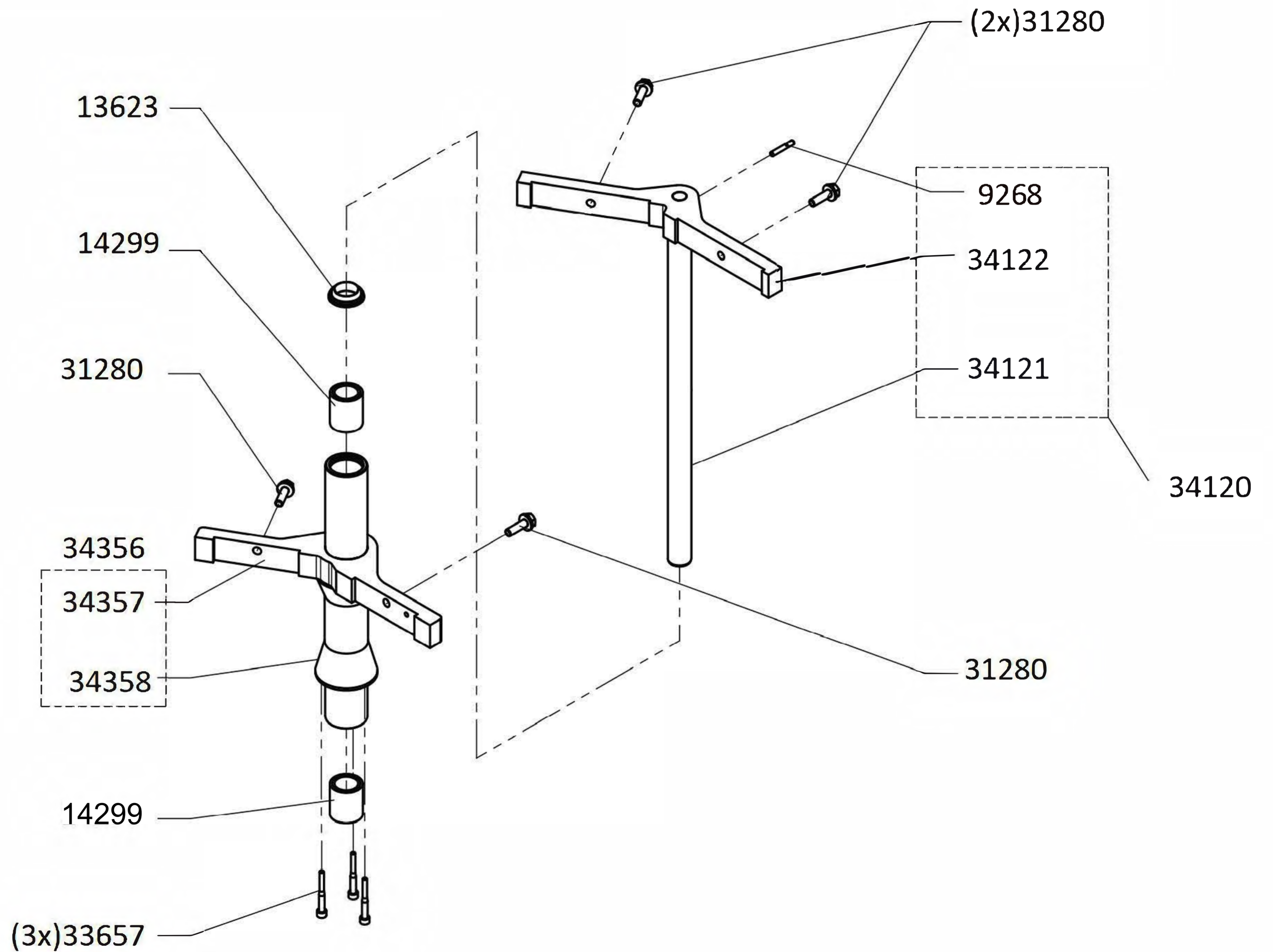

IIM

tel (336) 584-4777
fax (336) 584-9540
sales@iimnc.com
www.iimnc.com

Section 28: Capsule Sorting Station - 10CT

GKF3005 - revised 3/2/2022

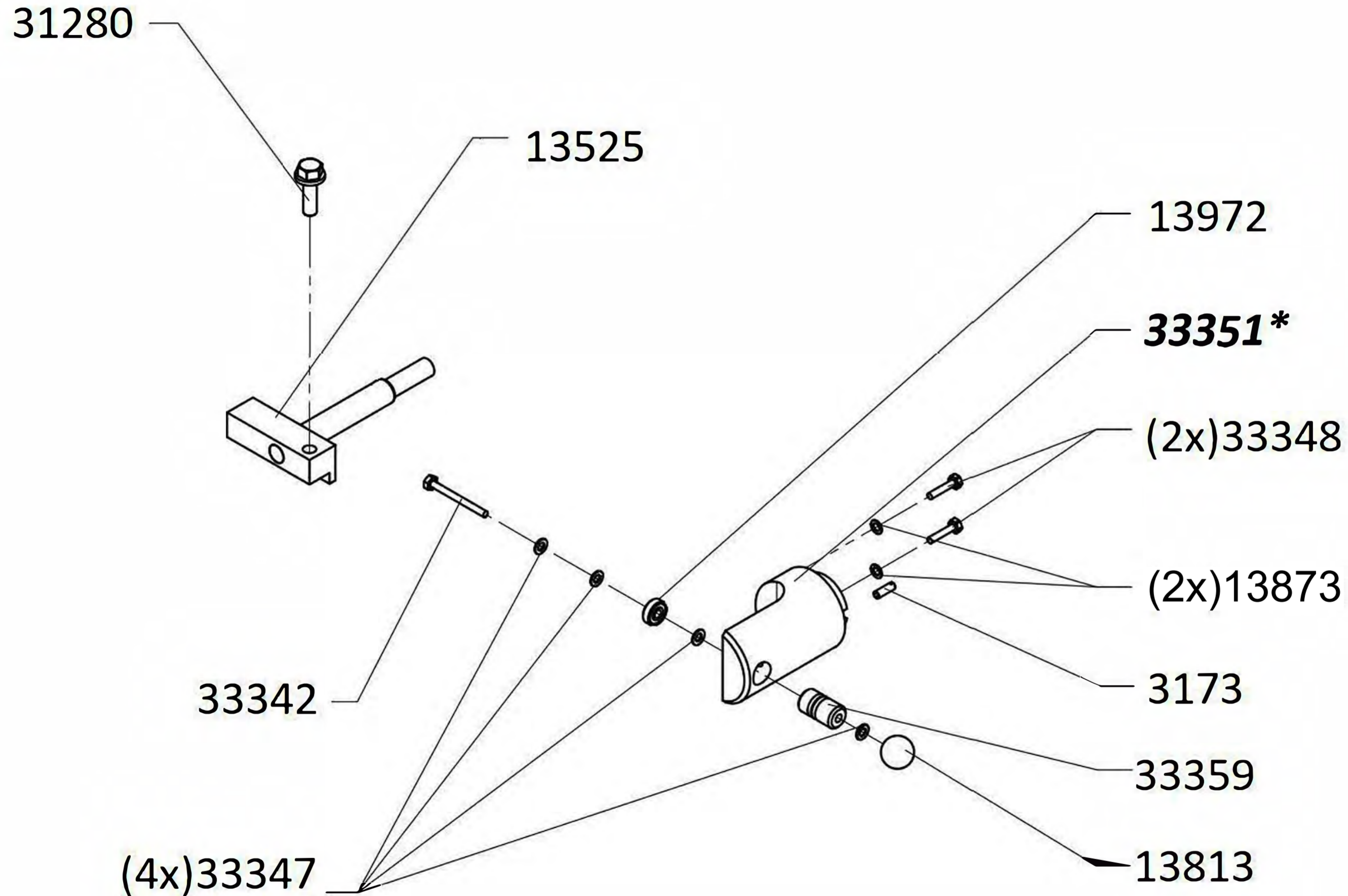

IIM

tel (336) 584-4777
fax (336) 584-9540
sales@iimnc.com
www.iimnc.com

All part numbers with an asterisk*
should not be ultrasonically cleaned
or submerged in a caustic/alkaline solution

Section 29: Capsule Sorting Station - 10CT

GKF3005 - revised 7/14/23

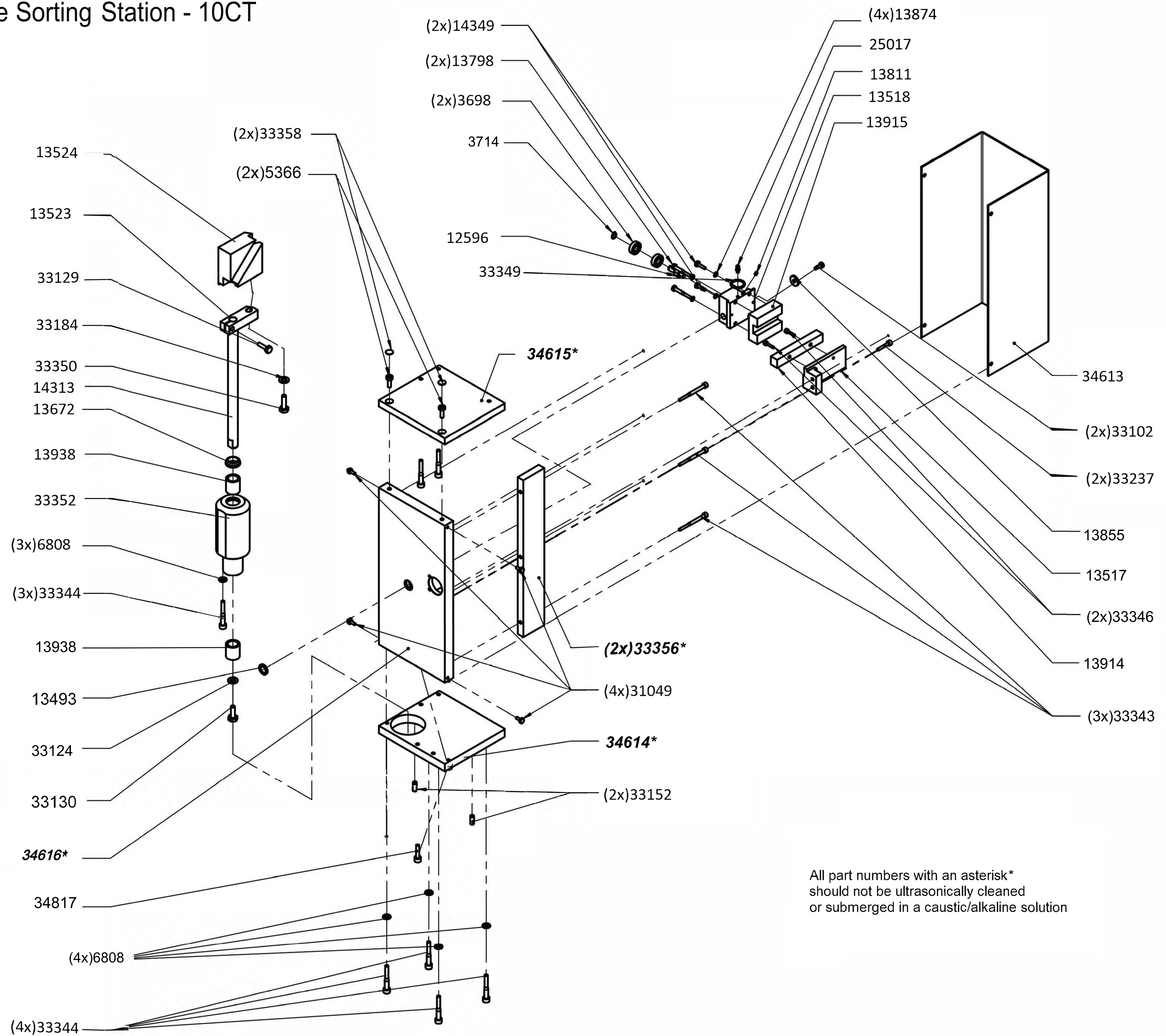

All part numbers with an asterisk*
should not be ultrasonically cleaned
or submerged in a caustic/alkaline solution

Section 30: Capsule Infeed Hopper

GKF3005 - revised 3/2/2022

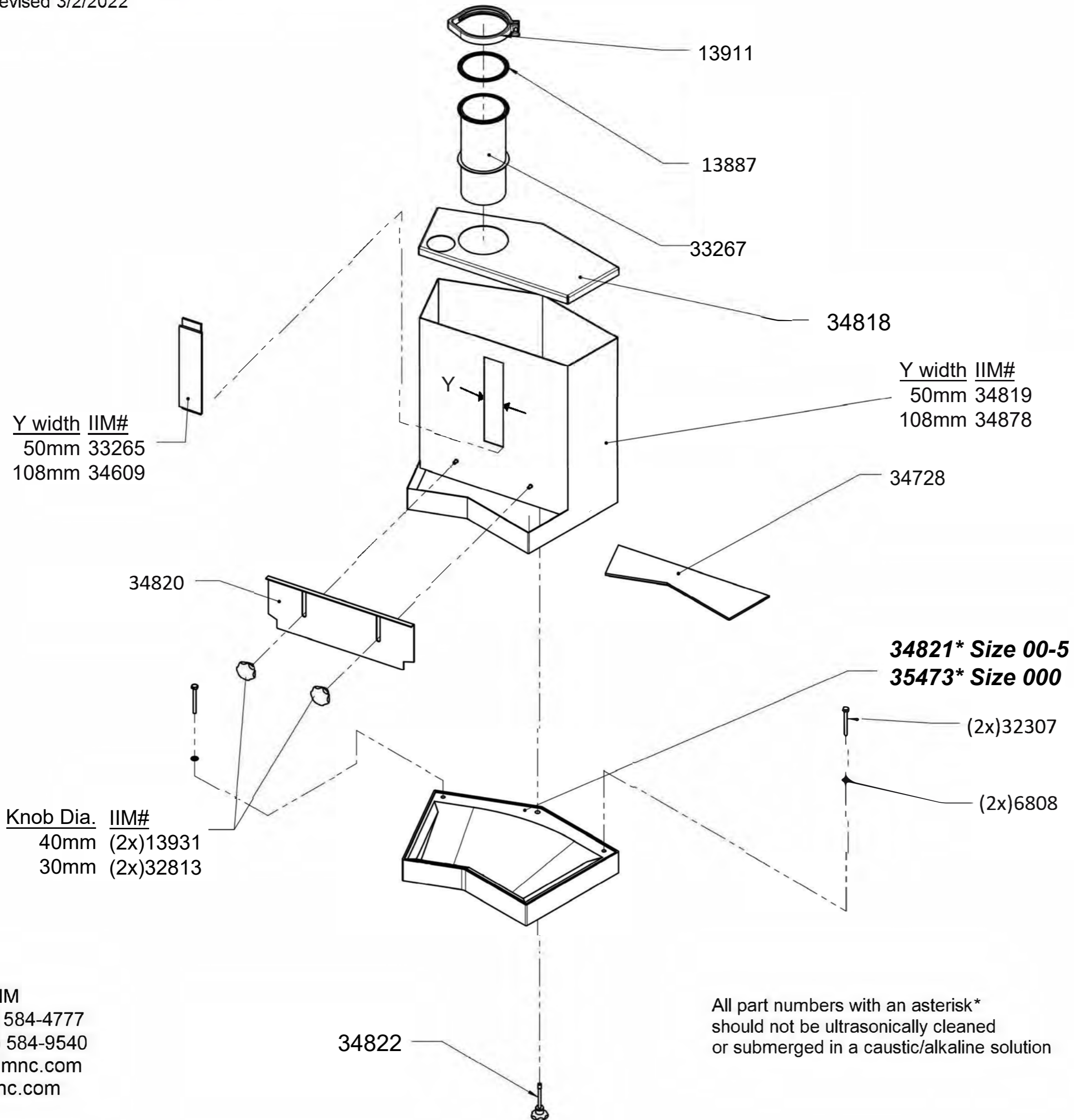

IIM
 tel (336) 584-4777
 fax (336) 584-9540
 sales@iimnc.com
 www.iimnc.com

All part numbers with an asterisk*
 should not be ultrasonically cleaned
 or submerged in a caustic/alkaline solution

Section 31: Faulty Capsule Ejection

GKF3005 - revised 3/2/2022

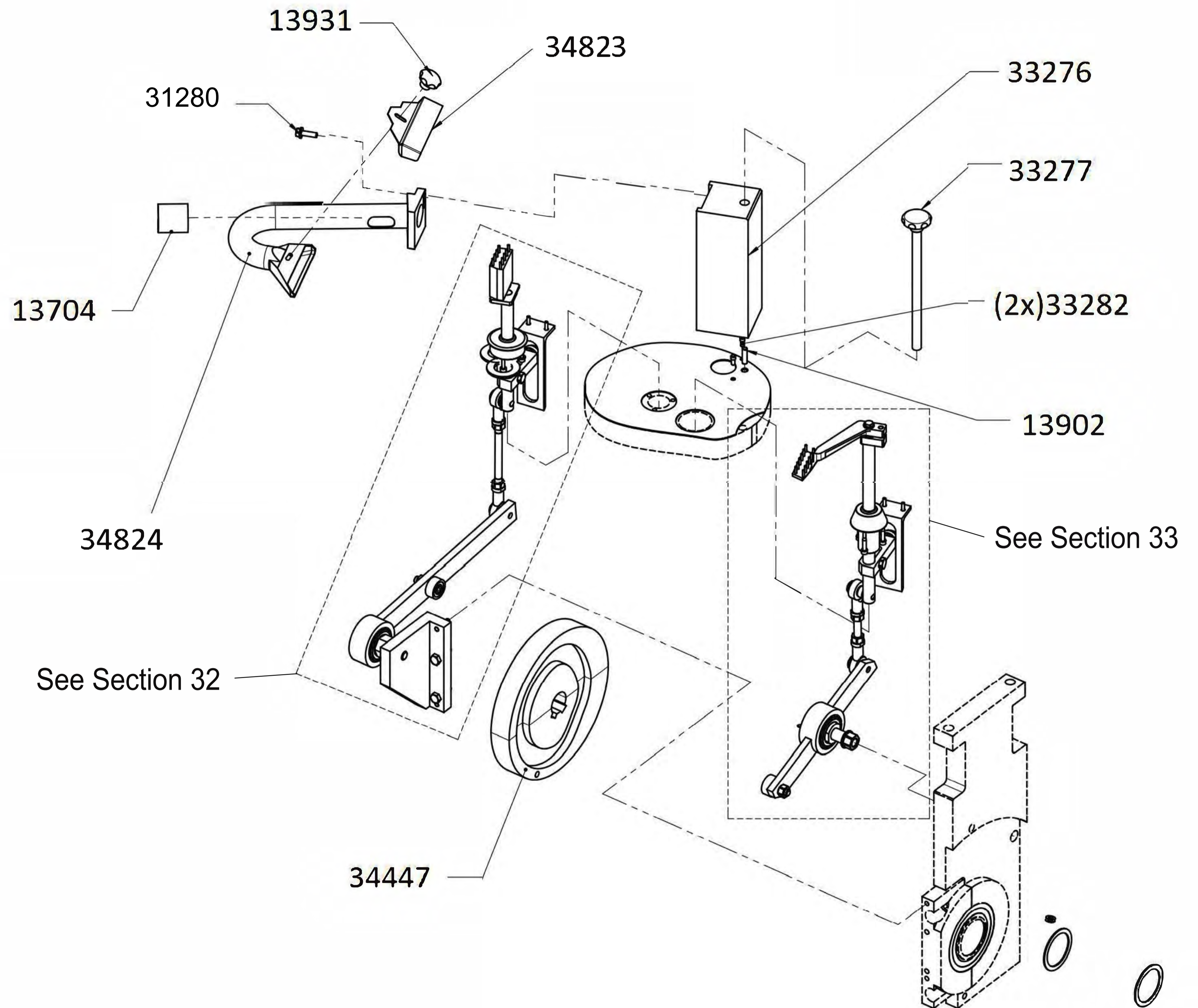

IIM

tel (336) 584-4777

fax (336) 584-9540

sales@iimnc.com

www.iimnc.com

Section 32: Faulty Capsule Ejection 9CT

GKF3005 - revised 7/14/2023

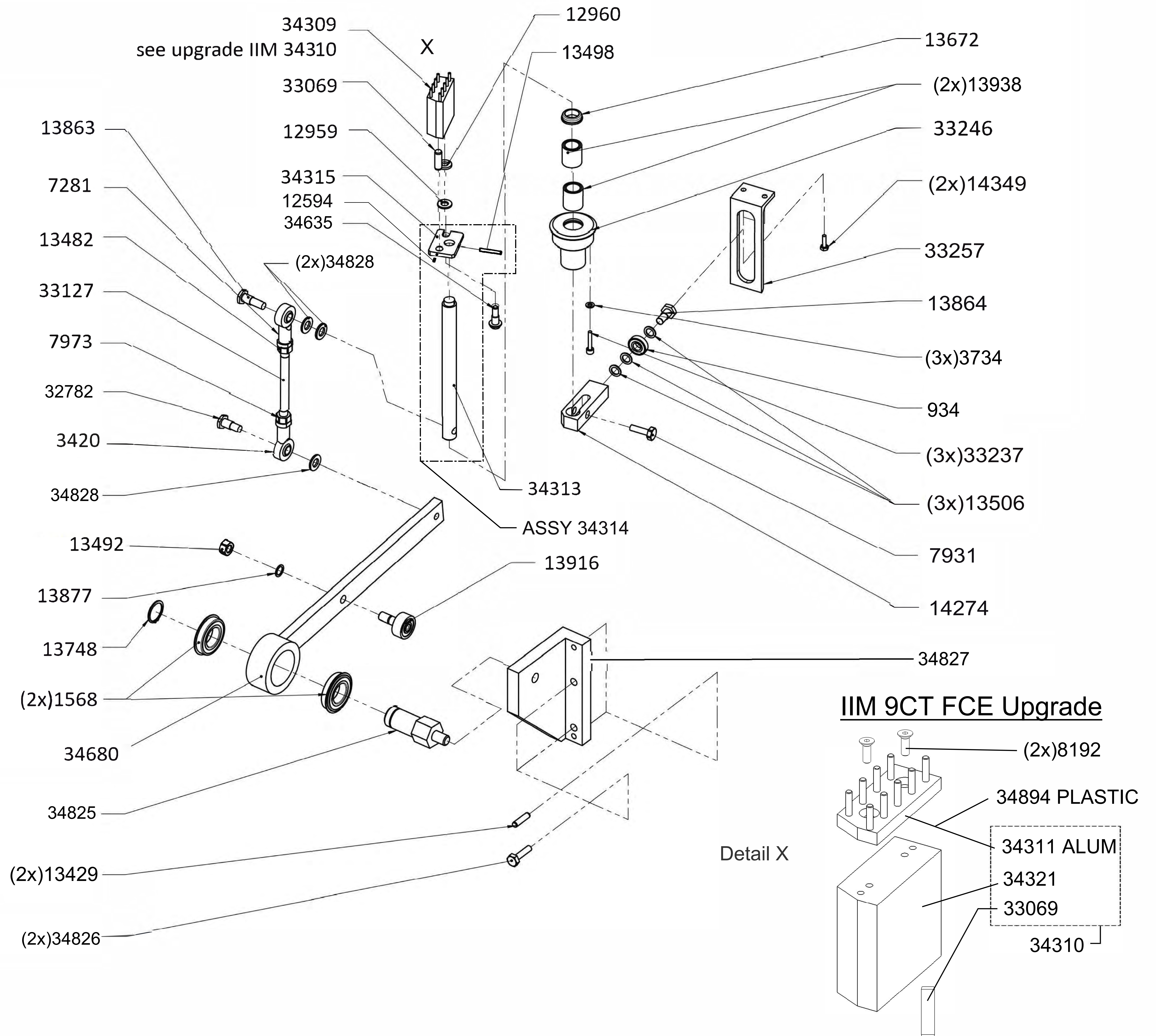

Section 33: Faulty Capsule Ejection 12CT

GKF3005 - revised 7/14/23

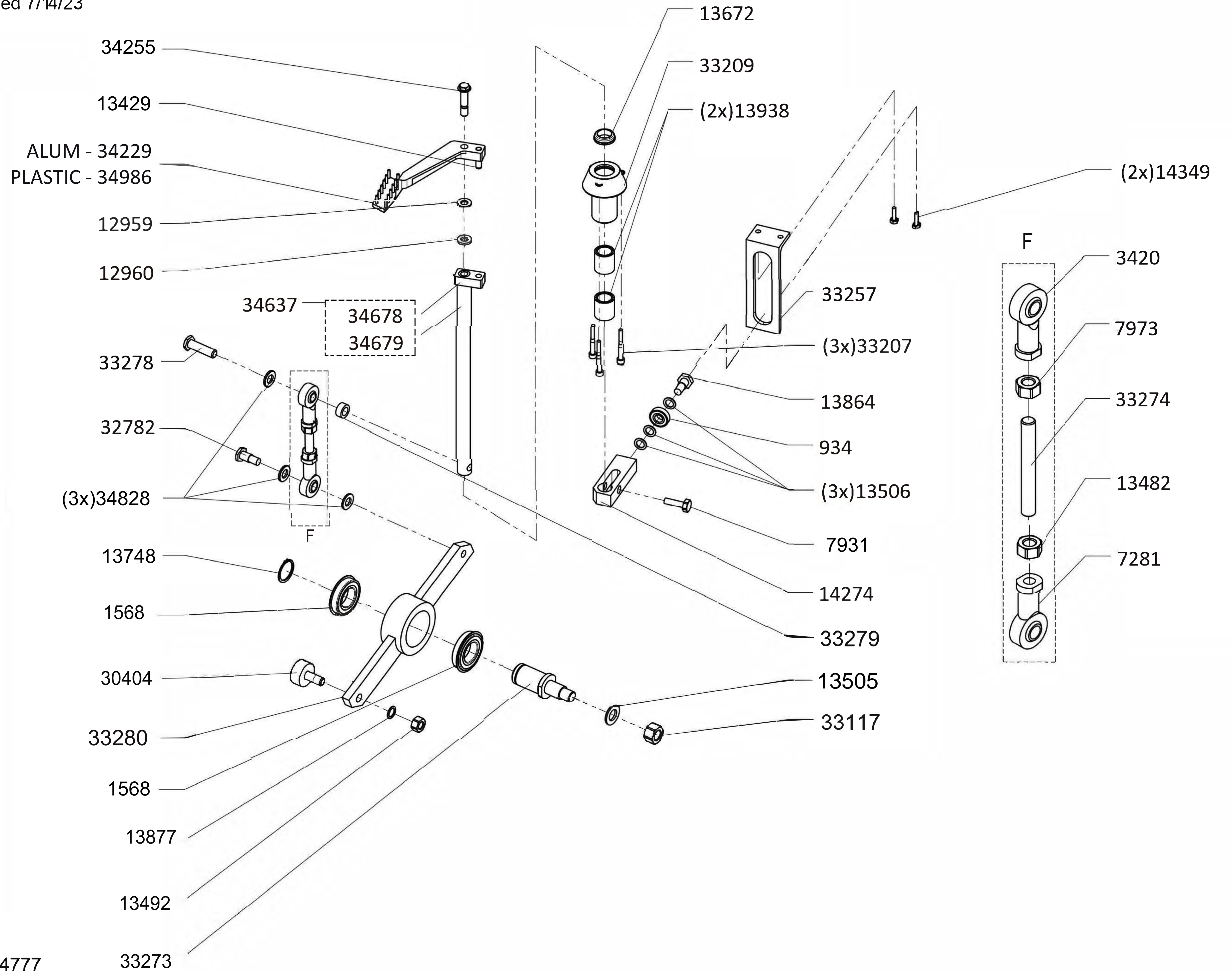

Section 34: Powder Dosing, Guide Ring & Bowl

GKF3005 - revised 6/9/2023

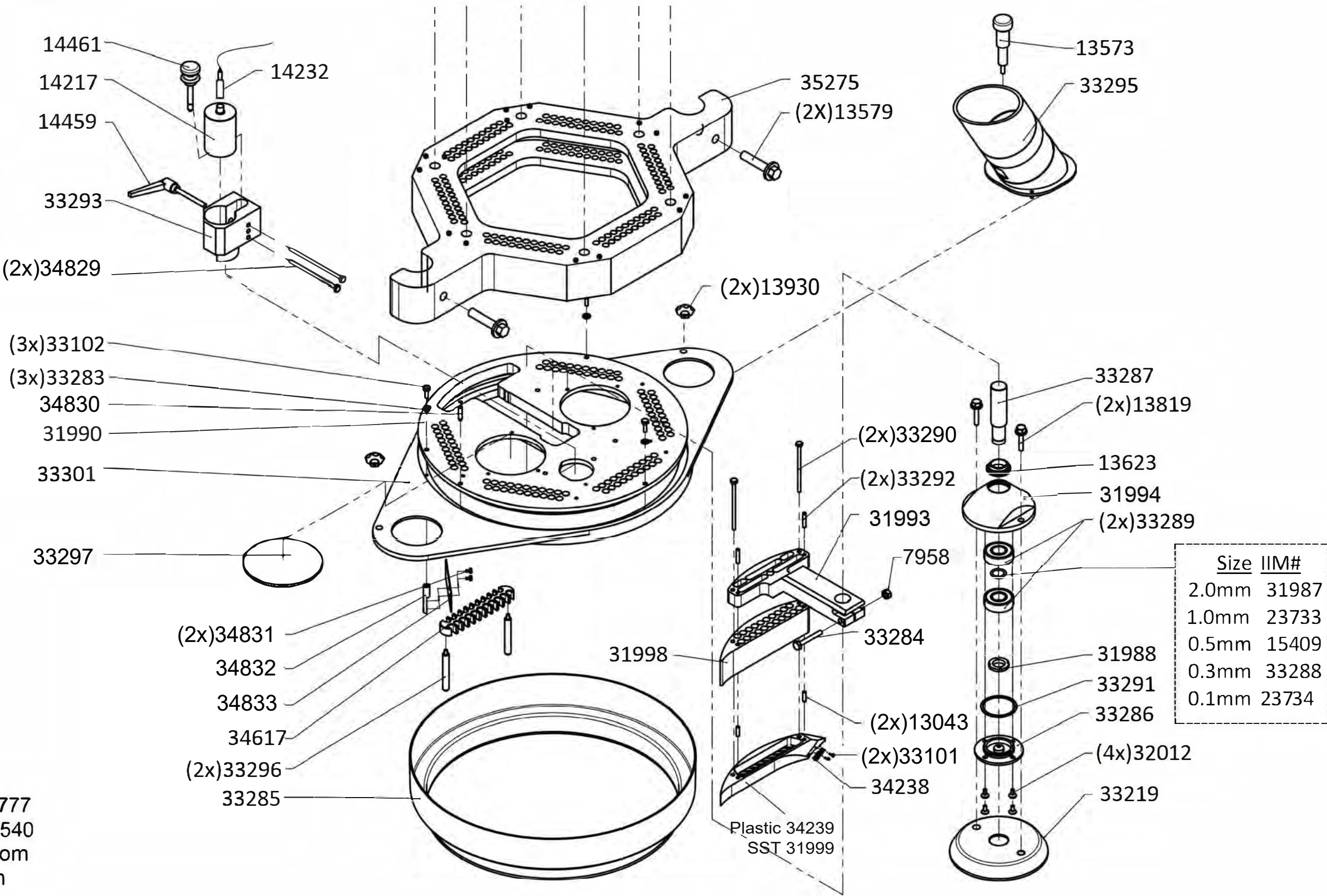

IIM
 tel (336) 584-4777
 fax (336) 584-9540
 sales@iimnc.com
 www.iimnc.com

Section 35: Tamping Head

GKF3005 - revised 3/2/2022

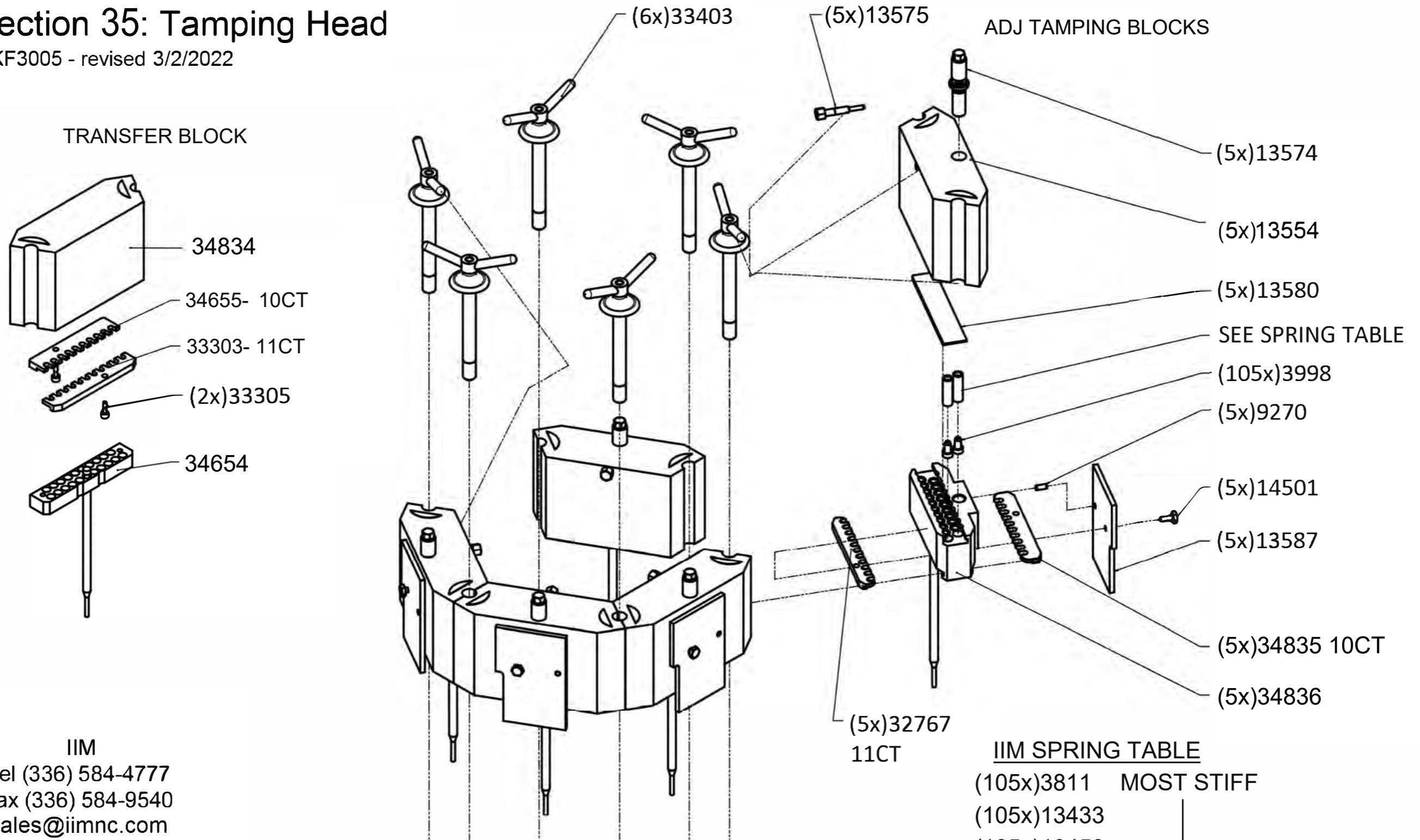

IIM SPRING TABLE

(105x)3811	MOST STIFF
(105x)13433	
(105x)10450	
(105x)32175	LEAST STIFF

↓

IIM
tel (336) 584-4777
fax (336) 584-9540
sales@iimnc.com
www.iimnc.com

Section 36: Ejection and Cleaning Station - 3 Shaft

GKF3005 - revised 12/9/2022

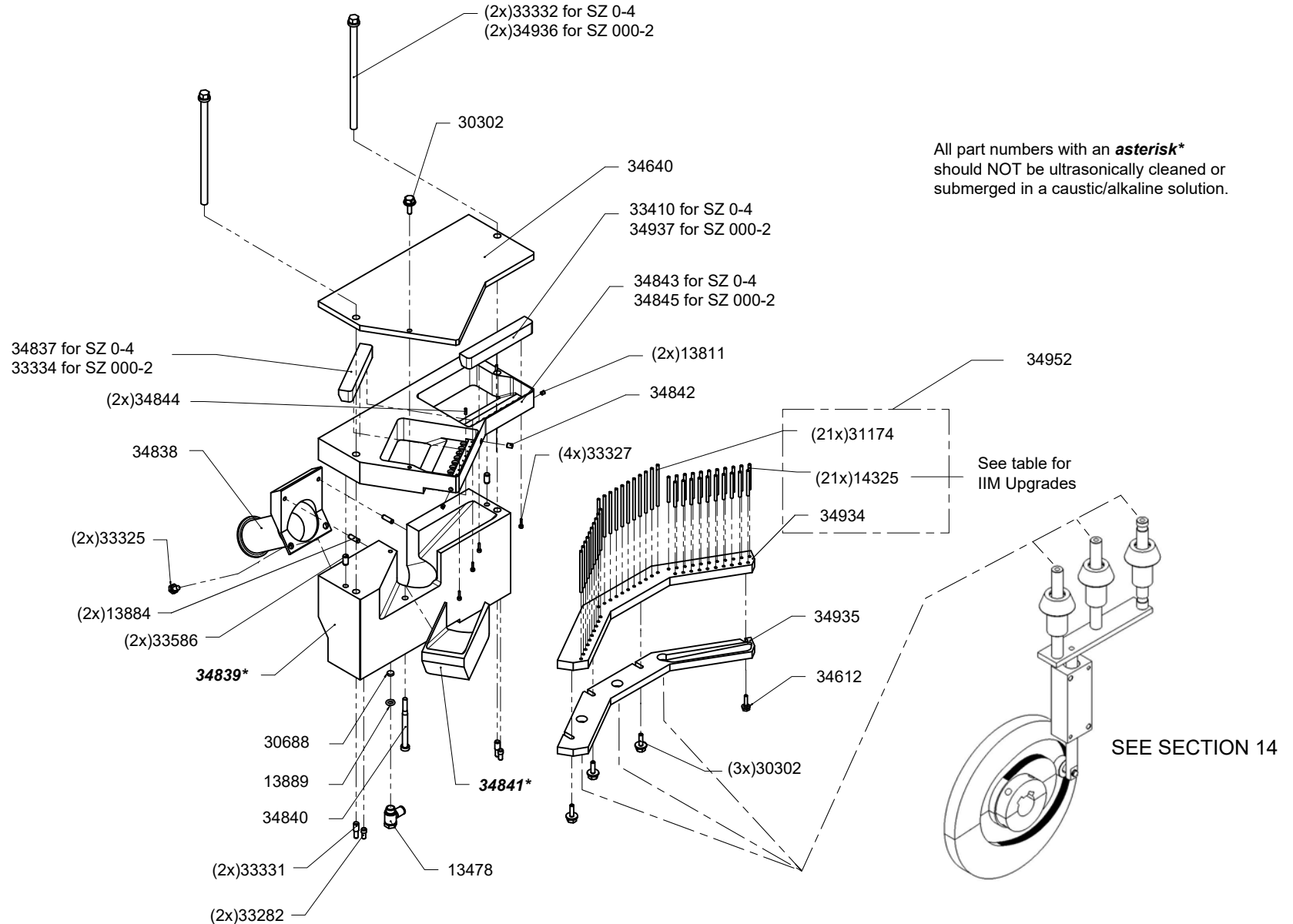

IIM
 tel (336)584-4777
 fax (336)584-9540
 sales@iimnc.com
 www.iimnc.com

Blowout Nozzles (21CT)					
Capsule Size:		000	00&0	1&2	3&4
Standard	Nozzle	14325			
for Brush	Improved Nozzle, accepts brush	33767			
	Brush	33759	31837	33776	34924

Section 36.1: Capsule Ejection & Cleaning Station - 2 Shaft

GKF3005 - revised 1/4/2023

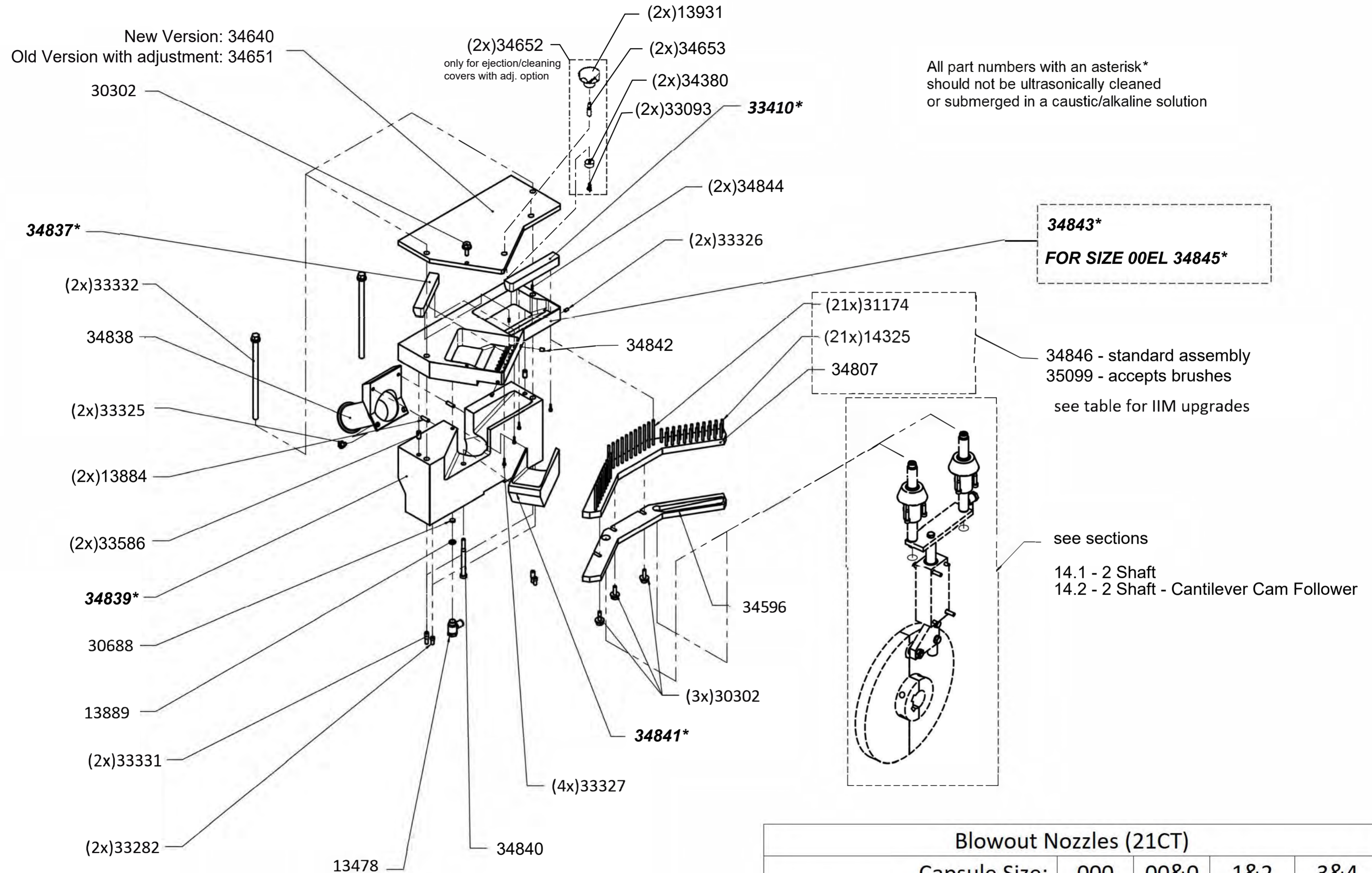

All part numbers with an asterisk* should not be ultrasonically cleaned or submerged in a caustic/alkaline solution

34843*
FOR SIZE 00EL 34845*

34846 - standard assembly
35099 - accepts brushes
see table for IIM upgrades

see sections
14.1 - 2 Shaft
14.2 - 2 Shaft - Cantilever Cam Follower

Blowout Nozzles (21CT)					
Capsule Size:		000	00&0	1&2	3&4
Standard	Nozzle	14325			
for Brush	Improved Nozzle, accepts brush	33767			
	Brush	33759	31837	33776	34924

Section 37: Cleaning Station

GKF3005 - revised 3/2/2022

All part numbers with an asterisk*
should not be ultrasonically cleaned
or submerged in a caustic/alkaline solution

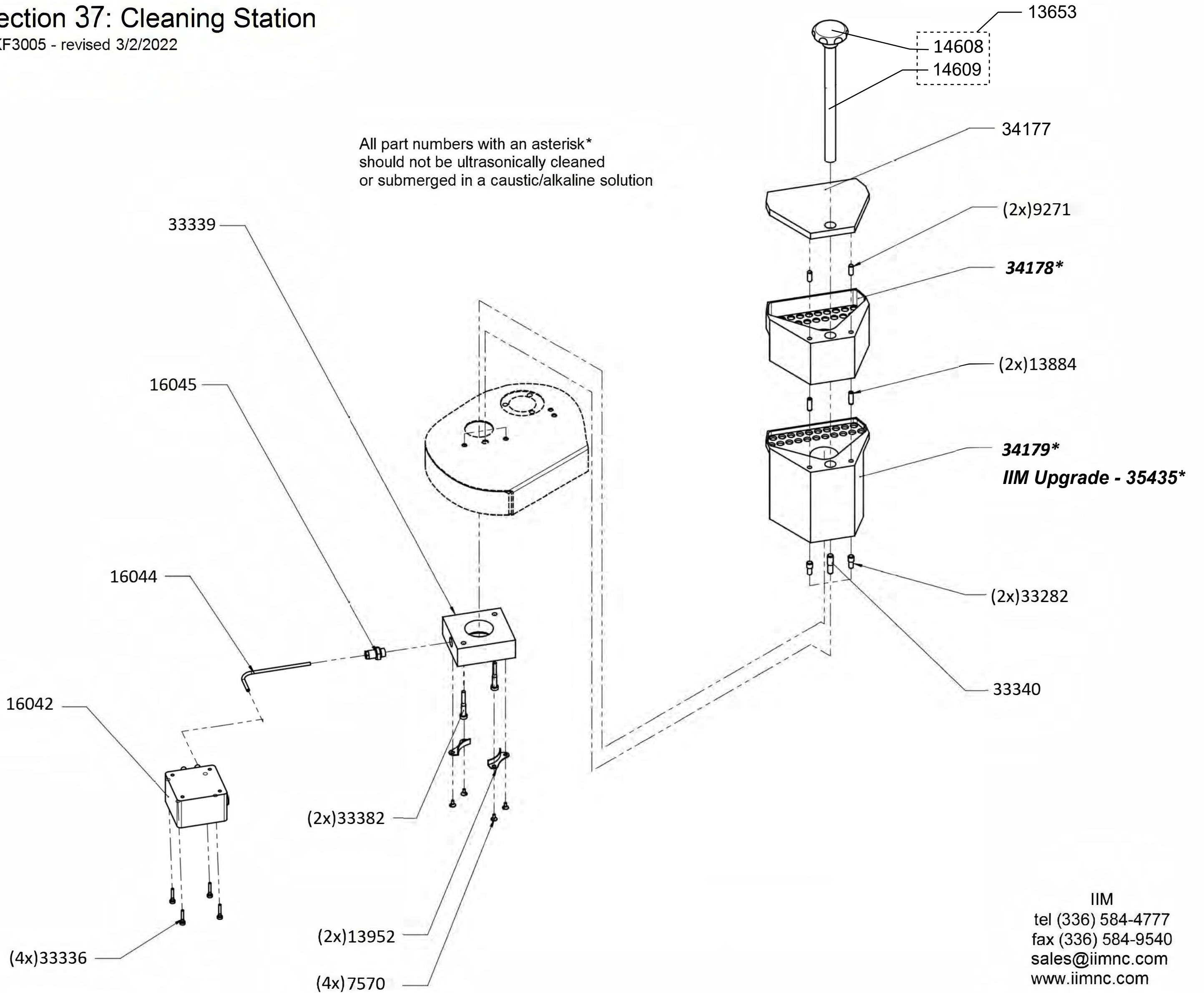

IIM
tel (336) 584-4777
fax (336) 584-9540
sales@iimnc.com
www.iimnc.com

GKF3005 Size Change Parts

21CT Dosing & Segment								
	<u>QTY</u>	<u>000</u>	<u>00</u>	<u>0</u>	<u>1</u>	<u>2</u>	<u>3</u>	<u>4</u>
Tamping Pins Standard	126x	13065	13066	12953	13062	13067	13068	13069
Tamping Pins MIRROR	126x	29851	29852	29853	29737	29854	29736	29855
CUSTOM TAMPING PINS AVAILBLE: MIRRORED, COATED, CUSTOM DIAMETER, ETC.								
Dosing Alignment Pin	2x	7289	3539	7291	4952	5188	5189	7293
Segment Alignment Pin	2x	13360	4923	8185	4924	5190	5191	13361
Dosing Disc	1x	34016	34017	34018	34019	34020	34021	34022
Upper Segment Block	12x	33998	33999	34000	34001	34002	34003	34004
Lower Segment Block	12x	34005	34006	34007	34008	34009	34010	34011
CUSTOM DOSING DISCS AND SEGMENT BLOCKS AVAILABLE								

10CT Capsule Sorting & Orientation								
	<u>QTY</u>	<u>000</u>	<u>00/00el</u>	<u>0/0el</u>	<u>1/1el</u>	<u>2/2el</u>	<u>3</u>	<u>4/4el</u>
Magazine, Complete	1x	34086	34078	34080	34087	34088	34089	34090
Vertical Fingers	1x	34038	34037	34039	34040	34041	34042	34043
Orientation Finger	1x	34023	34025	34024	34026	34027	34028	34029
Sorting Block	1x	34030	34031	34032	34033	34034	34035	34036

11CT Capsule Sorting & Orientation								
	<u>QTY</u>	<u>000</u>	<u>00/00el</u>	<u>0/0el</u>	<u>1/1el</u>	<u>2/2el</u>	<u>3</u>	<u>4/4el</u>
Magazine, Complete	1x	34085	34082	34084	34091	34092	34093	33037
Vertical Fingers	1x	Contact us	33043	33044	33045	33046	33047	33048
Orientation Finger	1x	34955	33049	33050	33051	33052	33053	33054
Sorting Block	1x	35470	33055	33056	33057	33058	33059	33060

COMPLETE KITS								
	<u>QTY</u>	<u>000</u>	<u>00/00el</u>	<u>0/0el</u>	<u>1/1el</u>	<u>2/2el</u>	<u>3</u>	<u>4/4el</u>
FULL SIZE CHANGE KIT*	1x	34055**	34056	34057	34058	34059	34060	34061
MAJOR PM KIT	1x	IIM: 35409 OEM: 34639						
MINOR PM KIT	1x	IIM: 35408 OEM: 34638						
MAIN SHAFT REBUILD	1x	34645						

*Dosing Disc sold separately

**Must purchase 000 Conversion Kit IIM#35474

Blowout Nozzles & Brushes M3								
	<u>QTY</u>	<u>000</u>	<u>00/00el</u>	<u>0/0el</u>	<u>1/1el</u>	<u>2/2el</u>	<u>3</u>	<u>4/4el</u>
Standard	Air Nozzle	21x	14325					
For Brush	Improved Nozzle, accepts brush	21x	33767					
	Brush	21x	33759	31837	33776	34924		

Lower Closing Pins								
	<u>QTY</u>	<u>000</u>	<u>00</u>	<u>0</u>	<u>1</u>	<u>2</u>	<u>3</u>	<u>4</u>
IIM Stainless Steel	21x	31638	16228		16230		16232	
IIM Aluminum	21x	contact us		28121		32634		32635
OEM Stainless Steel	21x	29580			29581		33316	

IIM #	Description	Section
934	BEARING	21
934	BEARING	21.1
934	BEARING	32
934	BEARING	33
1052	SCREW,SHC,M6	26
1568	BEARING	8
1568	BEARING	9
1568	BEARING	21
1568	BEARING	21.1
1568	BEARING	32
1568	BEARING	33
3173	SPRING PLUNGER	24
3173	SPRING PLUNGER	28
3378	LINEAR BEARING	10
3379	RADIAL BEARING	7
3379	RADIAL BEARING	14
3379	RADIAL BEARING	14.1
3379	RADIAL BEARING	14.2
3387	BEARING	4
3420	ROD END,RIGHT M12	8
3420	ROD END,RIGHT M12	21
3420	ROD END,RIGHT M12	21.1
3420	ROD END,RIGHT M12	32
3420	ROD END,RIGHT M12	33
3698	BEARING	24
3698	BEARING	29
3714	SNAP RING	24
3714	SNAP RING	29
3734	WASHER M6	4
3734	WASHER M6	7
3734	WASHER M6	9
3734	WASHER M6	9
3734	WASHER M6	11
3734	WASHER M6	12
3734	WASHER M6	21
3734	WASHER M6	21.1
3734	WASHER M6	25
3734	WASHER M6	26
3734	WASHER M6	32
3834	SPLIT BUSHING	11
3847	O-RING	11
3998	SPRING CAP	35
4160	FILTER	23
4986	SCREW,HEX M6	21.1

IIM #	Description	Section
5314	RETAINING RING	9
5366	SCREW	29
5386	SEAL RING	13
6808	WASHER M8	8
6808	WASHER M8	10
6808	WASHER M8	14.2
6808	WASHER M8	23
6808	WASHER M8	24
6808	WASHER M8	24
6808	WASHER M8	25
6808	WASHER M8	29
6808	WASHER M8	30
7281	ROD END,LEFT M12	8
7281	ROD END,LEFT M12	9
7281	ROD END,LEFT M12	32
7281	ROD END,LEFT M12	33
7364	BEARING	5
7937	SCREW,HEX M6	7
7948	SCREW,HEX	2
7948	SCREW,HEX	4
7959	NUT M10	7
7973	NUT M12	8
7973	NUT M12	9
7973	NUT M12	21
7973	NUT M12	21
7973	NUT M12	21.1
7973	NUT M12	32
8088	WASHER M4	25
8088	WASHER M4	26
8192	SCREW,FLAT M4	32
8290	HOSE	23
9266	DOWEL PIN	11
9270	DOWEL PIN	35
9271	PIN	21.1
9289	DOWEL PIN	7
12594	SET SCREW,M4	25
12594	SET SCREW,M4	26
12594	SET SCREW,M4	32
12596	SCREW	24
12596	SCREW	29
12953	TAMPING PIN SZ0	17
12959	SPACER 3MM	32
12959	SPACER 3MM	33
12960	SPACER 2MM	32

IIM #	Description	Section	IIM #	Description	Section
12960	SPACER 2MM	33	13498	PIN	32
12969	MAG MOUTHPIECE SHAFT	18	13503	BUSHING	11
12969	MAG MOUTHPIECE SHAFT	19	13505	WASHER M16	2
12970	SPRING	18	13505	WASHER M16	4
12970	SPRING	19	13505	WASHER M16	11
12972	PLATE,CAPTURE,MAG MOUTHPIECE TRIP	18	13506	SHIM	14
12972	PLATE,CAPTURE,MAG MOUTHPIECE TRIP	19	13506	SHIM	14.1
12973	LEAF SPRING FINGERS	18	13506	SHIM	14.2
12973	LEAF SPRING FINGERS	19	13506	SHIM	21
12974	MAG MOUTHPIECE CAM	18	13506	SHIM	21.1
12974	MAG MOUTHPIECE CAM	19	13506	SHIM	32
13043	PIN	34	13506	SHIM	33
13062	TAMPING PIN SZ1	17	13507	THRUST BEARING	11
13066	TAMPING PIN SZ00	17	13509	ROLLER BEARING	2
13067	TAMPING PIN SZ2	17	13517	ORIENT FINGERS BLOCK	24
13068	TAMPING PIN SZ3	17	13517	ORIENT FINGERS BLOCK	29
13069	TAMPING PIN SZ4	17	13518	SORTING DRIVE BLOCK	24
13120	WASHER	4	13518	SORTING DRIVE BLOCK	29
13142	SCREW,HEX M4	7	13523	CLAMPING BLOCK	24
13433	SPRING	35	13523	CLAMPING BLOCK	29
13437	PIN,DOWEL	22	13524	GUIDE BLOCK	24
13460	HOSE CLAMP	23	13524	GUIDE BLOCK	29
13478	SWIVEL FITTING	14	13525	SHAFT	24
13478	SWIVEL FITTING	14.1	13525	SHAFT	28
13478	SWIVEL FITTING	14.2	13554	TAMPING BLOCK HOUSING	35
13478	SWIVEL FITTING	36	34899	POWDER FEED AUGER	13
13478	SWIVEL FITTING	36.1	13573	SCREW	34
13485	DOWEL PIN	7	13574	GUIDE SCREW	35
13490	SET SCREW	18	13575	SCREW	35
13490	SET SCREW	19	13579	SCREW	34
13492	NUT M12	8	13580	TOP PLATE,TAMPING	35
13492	NUT M12	9	13581	SEAL	10
13492	NUT M12	14	13585	FLANGE	10
13492	NUT,HEX	14.1	13587	RETAINING PLATE	35
13492	NUT,HEX	14.2	13595	SHAFT,POWDER AUGER	13
13492	NUT M12	21	13596	CHOPPER,POWDER AUGER	13
13492	NUT M12	21.1	13597	LOCK NUT	11
13492	NUT M12	32	13600	BASE,ADJUSTMENT,DOSING DISC	11
13492	NUT M12	33	13601	SHAFT,DOSING	11
13493	SEAL	24	13602	GUIDE BLOCK	11
13493	SEAL	29	13604	POST	11
13494	SCREW,SHC	7	13618	SCREW,HEX	21
			13618	SCREW,HEX	21.1
			13623	SEAL	21

IIM #	Description	Section	IIM #	Description	Section
13623	SEAL,RED,25MM	21.1	13750	CIRCLIP	3
13623	SEAL,RED,25MM	27	13757	SCREW,HEX M8	13
13623	SEAL,RED,25MM	34	13759	SCREW,SHC M8	21
13625	BLOCK,LOWER CLOSING	21	13759	SCREW,SHC M8	21.1
13625	BLOCK,LOW CLOSING	21.1	7931	SCREW,HEX M10	32
13627	SPACER,LOWER CLOSING ADJ	21	7931	SCREW,HEX M10	33
13627	SPACER,LOWER CLOSING ADJ	21.1	13769	NUT M6	13
13633	SHAFT,LINEAR,EJECTION DRIVE	14	13770	NUT	13
13633	SHAFT,LINEAR,EJECTION DRIVE	14.1	13771	NUT	7
13633	SHAFT,LINEAR,EJECTION DRIVE	14.2	13777	SHIM	7
13651	SHAFT,DRIVE,SEGMENT CLEANING	14	13777	SHIM	11
13651	SHAFT,DRIVE,SEGMENT CLEANING	14.1	13777	SHIM	14
13651	SHAFT,DRIVE,SEGMENT CLEANING	14.2	13777	SHIM	14.1
13653	HAND KNOB ASSY	37	13777	SHIM	14.2
13667	UPPER SEG CAM FOLLOW BLOCK	7	13778	SCREW,HEX M6	13
13671	PLATE, SEG TURRET GENEVA	7	13780	GEARBOX	7
13674	SEAL,RED,12MM	7	13783	SCREW	15
13675	SCREW,HEX	7	13785	NUT	10
13677	SCREW,HEX	7	13787	SEAL STRIP	13
13678	SCREW,HEX	7	13795	BEARING	7
13680	LOWER SEGMENT CARRIER	7	13798	SCREW, M6	24
13704	COLLAR,SLIDE,VACUUM ADJUSTMENT	31	13798	SCREW, M6	29
13712	EJECTION CAM	4	13803	SHIM	10
13712	EJECTION CAM	14	13805	SCREW,SHC M8	12
13712	EJECTION CAM	14.1	13805	SCREW,SHC M8	21
13712	EJECTION CAM	14.2	13805	SCREW,SHC M8	21.1
13715	SORTING CAM	3	13808	SCREW,SHC	14
13715	SORTING CAM	8	13808	SCREW,SHC	14.1
13716	LEVER ARM,SORTING	8	13808	SCREW,SHC	14.2
13727	SLIP CLUTCH	11	13810	SET SCREW	11
13728	TIMING PULLEY	7	13811	SET SCREW	24
13729	TIMING PULLEY	11	13811	SET SCREW	29
13730	TIMING PULLEY	3	13811	SET SCREW	36
13731	COVER PLATE	2	13813	KNOB	24
13735	WASHER	10	13813	KNOB	28
13736	CROSS MEMBER ARM	10	13819	SCREW M8	15
13737	TIMING PULLEY	1	13819	SCREW M8	34
13741	COLLAR	11	13821	WASHER	21
13748	CIRCLIP	8	13821	WASHER	21.1
13748	CIRCLIP	9	13825	TIMING DIAL	4
13748	CIRCLIP	21	13827	ROD END,MALE	21
13748	CIRCLIP	21.1	13827	ROD END,MALE	21.1
13748	CIRCLIP	32	13842	HOSE CLAMP	23
13748	CIRCLIP	33	13847	SCREW,SHC M16	2

IIM #	Description	Section	IIM #	Description	Section
13847	SCREW,SHC M16	7	13877	WASHER M12	8
13850	SCREW,HEX M8	14	13877	WASHER M12	9
13850	SCREW,HEX M8	14.1	13877	WASHER M12	10
13850	SCREW,HEX M8	14.2	13877	WASHER M12	11
13855	WASHER	24	13877	WASHER M12	21
13855	WASHER	29	13877	WASHER M12	21.1
13857	WASHER	7	13877	WASHER M12	32
13858	SPACER	1	13877	WASHER M12	33
13859	SPACER	11	13878	WASHER M16	2
13861	SHIM	7	13878	WASHER M16	3
13862	SCREW	14	13878	WASHER,M16	11
13862	SCREW	14.1	13884	DOWEL PIN	14
13862	SCREW	14.2	13884	DOWEL PIN	14.1
13863	SCREW,M12	8	13884	DOWEL PIN	14.2
13863	SCREW,M12	21	13884	DOWEL PIN	21
13863	SCREW,M12	21.1	13884	DOWEL PIN	21.1
13863	SCREW,M12	32	13884	DOWEL PIN	24
13864	SCREW,HEX	21	13884	DOWEL PIN	36
13864	SCREW,HEX	21.1	13884	DOWEL PIN	36.1
13864	SCREW,HEX	32	13884	DOWEL PIN	37
13864	SCREW,HEX	33	13887	GASKET	30
13866	SPACER	14	13888	NUT	21
13866	SPACER	14.1	13888	NUT	21.1
13866	SPACER	14.2	13889	O-RING	36
13868	O-RING	11	13889	O-RING	36.1
13873	WASHER M5	24	13890	DOWEL PIN	15
13873	WASHER M5	28	13896	STUD	10
13874	WASHER M6	14	13896	STUD	21
13874	WASHER M6	14.1	13896	STUD	21.1
13874	WASHER M6	14.2	13898	SCREW,SHC M10	7
13874	WASHER M6	24	13902	STUD	21
13874	WASHER M6	29	13902	STUD	21.1
13875	WASHER M8	2	13902	STUD	31
13875	WASHER M8	9	13903	WIRE TUBING	23
13875	WASHER M8	14	13908	THREADED ROD	11
13875	WASHER M8	14.1	13909	SCREW,HEX M4	25
13875	WASHER M8	14.2	13909	SCREW,HEX M4	26
13875	WASHER M8	20	13911	CLAMP	30
13876	WASHER M10	1	13914	BEARING GUIDE	24
13876	WASHER M10	3	13914	BEARING GUIDE	29
13876	WASHER M10	7	13915	LINEAR BEARING	24
13877	WASHER M12	1	13915	LINEAR BEARING	29
13877	WASHER M12	4	13916	CAM FOLLOWER	8
13877	WASHER M12	7	13916	CAM FOLLOWER	9

IIM #	Description	Section	IIM #	Description	Section
13916	CAM FOLLOWER	21	14273	LINEAR SHAFT	14.2
13916	CAM FOLLOWER	21.1	14274	BRACKET,CLAMPING,FCE DRIVE SHAFT	32
13916	CAM FOLLOWER	32	14274	BRACKET,CLAMPING,FCE DRIVE SHAFT	33
13917	HUB	2	14299	LINEAR BEARING	21
13918	TIMING BELT	3	14299	LINEAR BEARING	21.1
13921	SCREW	10	14299	LINEAR BEARING	27
13923	SCREW	10	14313	OREINT DRIVE SHAFT	24
13930	HAND KNOB	12	14313	OREINT DRIVE SHAFT	29
13930	HAND KNOB	21	14315	THREADED ROD	7
13930	HAND KNOB	22	14325	BLOWOUT NOZZLE	36
13930	HAND KNOB	34	14325	BLOWOUT NOZZLE	36.1
13931	HAND KNOB	13	14349	SCREW,HEX M6	24
13931	HAND KNOB	21	14349	SCREW,HEX M6	25
13931	HAND KNOB	21.1	14349	SCREW,HEX M6	26
13931	HAND KNOB	30	14349	SCREW,HEX M6	29
13931	HAND KNOB	31	14362	VACUUM VALVE	23
13936	BELT,MAIN DRIVE	1	14364	COUNTER	11
13937	BEARING	7	14365	COUNTER PLATE	11
13938	BEARING	7	14368	TIMING BELT	2
13938	BEARING	14	14369	WASHER	1
13938	BEARING	14.1	14414	SHIM	9
13938	BEARING	14.2	14448	CUSTOM HEX	11
13938	BEARING	24	14449	PIN	11
13938	BEARING	25	14450	PULLEY	2
13938	BEARING	26	14452	TURRET SEAL	7
13938	BEARING	29	14459	LOCKING HANDLE	34
13938	BEARING	32	14461	KNOB	34
13938	BEARING	33	14466	NUT	1
13940	ROLLER,TENSION,ASSY	2	14500	WASHER	7
13940	ROLLER,TENSION,ASSY	5	14501	SCREW,HEX	7
13947	BEARING	3	14501	SCREW,HEX	35
13949	TORQUE LIMITER	1	14587	BRACKET,TAMPING SHAFT	10
13952	SPLIT RING	21	14588	SPRING	10
13952	SPLIT RING	21.1	14589	COUNTERWEIGHT,CAM	4
13952	SPLIT RING	37	14591	BRACKET,TAMPING SHAFT	10
13958	SENSOR	2	14592	THREADED INSERT	10
13970	WASHER M12	12	14608	HAND KNOB	37
13971	COLLAR	11	14609	ROD FOR HAND KNOB	37
13972	BEARING	24	15036	RETAINING RING	10
13972	BEARING	28	15037	RETAINING RING	5
14217	SENSOR	34	15290	SET SCREW	8
14232	CABLE,5M	34	15290	SET SCREW	9
14273	LINEAR SHAFT	14	15291	SCREW,SHC	8
14273	LINEAR SHAFT	14.1	15291	SCREW,SHC	9

IIM #	Description	Section	IIM #	Description	Section
16040	SCREW,SHC M6	5	31280	SCREW M8	28
16042	CONTROLLER	37	31280	SCREW M8	31
16044	TUBING	23	31281	DOSING DISC BOX	16
16044	TUBING	37	31281	DOSING DISC BOX	17
16045	FITTING	37	31360	DOWEL PIN	15
25017	GREASE FITTING	24	31360	DOWEL PIN	20
25017	GREASE FITTING	29	31363	THREADED STUD	21
26608	UPPER SEGMENT CARRIER	7	31363	THREADED STUD	21.1
28117	DOWEL PIN	18	31386	SCREW M8	12
28117	DOWEL PIN	19	31411	O-RING	24
28208	PIN,DOWEL	25	31436	SCREW,HEX	15
28470	WASHER	9	31987	SHIM	34
28479	POWDER GUARD	15	31988	NUT	34
28480	SCREW	15	31990	LEVEL SENSOR PLATE	34
29359	TAMPING CAM	2	31993	WIPER BLOCK ARM	34
29359	TAMPING CAM	10	31994	WIPER BLOCK CENTER CONE	34
29405	CLAMP,LOW SEGMENT CARRIER	7	31998	WIPER BLOCK	34
13672	SEAL	7	31999	WIPER BLOCK SHOE	34
13672	SEAL	14	32004	SHIM	34
13672	SEAL	14.1	32005	SHIM	34
13672	SEAL	14.2	32008	SHIM	34
13672	SEAL	24	9268	DOWEL PIN	24
13672	SEAL	25	9268	DOWEL PIN	27
13672	SEAL	26	32012	SCREW	34
13672	SEAL	29	32035	GEARBOX	11
13672	SEAL	32	32041	SCREW	15
13672	SEAL	33	32106	SCREW M10	15
30300	CAP,PROTECT,POWDER HOPPER OUTLET	13	32165	DOSING DISC BOX	16
30302	SCREW,HEX	36	32165	DOSING DISC BOX	17
30302	SCREW,HEX	36.1	32304	SCREW,HEX M16	2
30404	CAM FOLLOWER	14	32401	SCREW,HEX	4
30404	CAM FOLLOWER	14.1	32429	DOWEL PIN	3
30404	CAM FOLLOWER	14.2	32429	DOWEL PIN	4
30404	CAM FOLLOWER	33	32688	SCREW	13
30688	DISC,FILTER	36	32695	TAMPING RING	11
30688	DISC,FILTER	36.1	32695	TAMPING RING	16
31016	SCREW,SHC	15	32696	TAMPING RING	11
31049	SCREW,HEX	29	32767	RETAINING FINGER PLATE	35
31174	EJECTION PIN	36	32769	SCREW,HEX	21
31174	EJECTION PIN	36.1	32769	SCREW,HEX	21.1
31280	SCREW M8	15	32780	SCREW,HEX M6	25
31280	SCREW M8	24	32781	LOWER CLOSING LEVER	21
31280	SCREW M8	27	32782	SCREW, HEX M12	9
			32782	SCREW, HEX M12	21

IIM #	Description	Section	IIM #	Description	Section
32782	SCREW, HEX M12	21.1	33092	SCREW,HEX M8X20	3
32782	SCREW, HEX M12	32	33092	SCREW,HEX M8X20	14
32782	SCREW, HEX M12	33	33092	SCREW,HEX M8X20	14.1
32779	SCREW,HEX w/ washer	7	33092	SCREW,HEX M8X20	14.2
32798	SCREW M6	21	33093	SCREW M4	3
32798	SCREW M6	21.1	33094	SPROCKET	3
32799	BRACKET,GUIDE BEARING,LOWER CLOSING	21	33095	BRACKET,PIVOT,LEVER ARMS,1505/3005	3
32799	BRACKET,GUIDE BEARING,LOWER CLOSING	21.1	33096	BRACKET,PIVOT,LEVER ARMS,1505/3006	3
32804	SCREW,M8 CUSTOM	15	33097	SHAFT,MAIN	3
32811	SIGHT GLASS	13	33097	SHAFT,MAIN	9
32813	KNOB M6	30	33098	SCREW,HEX	4
32814	COMPRESSION SPRING	25	33100	SCREW,SHC	4
32814	COMPRESSION SPRING	26	33101	SCREW	4
33067	SCREW	1	33101	SCREW	34
33068	SCREW	1	33102	SCREW,HEX	4
33069	PIN,DOWEL	2	33102	SCREW,HEX	15
33069	PIN,DOWEL	32	33102	SCREW,HEX	18
33071	SCREW	2	33102	SCREW,HEX	19
33073	WASHER	2	33102	SCREW,HEX	24
33073	WASHER	4	33102	SCREW,HEX	29
33074	ROLLER,TENSION,HOUSING	5	33102	SCREW,HEX	34
33075	SCREW,HEX	2	33103	BRACKET,MOUNTING,MAIN DRIVE	4
33075	SCREW,HEX	25	33104	BRACKET,MOUNTING,SHAFT ENCODER	4
33076	WASHER	2	33105	ENCODER,SHAFT,MAIN DRIVE	4
33077	SCREW	2	33106	BUSHING	4
33077	SCREW	12	33107	CAP,END	5
33077	SCREW	24	33108	CAP,END	5
33078	SCREW,HEX	2	33109	WASHER	5
33078	SCREW,HEX	3	33110	WASHER,SHIM	5
33079	SCREW	2	33111	SCREW	7
33080	PLATE,MAIN SHAFT SUPPORT,CENTER	2	33112	SCREW,SHC	7
33081	BLOCK,MOUNTING,FRAME TO BRACKET	2	33113	SCREW,HEX	7
33083	BLOCK,MOUNTING,BELT TENSIONER	2	33113	SCREW,HEX	11
33084	SCREW,SHC	3	33114	SEGMENT TRAVERSING CAM	7
33085	SCREW,SHC	3	33114	SEGMENT TRAVERSING CAM	20
33085	SCREW,SHC	9	33115	SCREW	7
33087	CLIP	3	33115	SCREW	25
33088	TUBE	3	33116	SCREW	7
33089	CAM,SORTING	3	33117	NUT,HEX	33
33089	CAM,SORTING	21	33118	SCREW	7
33090	SCREW,SET	3	33119	SEAL,TURRET	7
33091	BEARING	3	33120	SPACER,SPLIT,SEGEMENT GEARBOX	7

IIM #	Description	Section	IIM #	Description	Section
33121	GASKET	7	7958	NUT,HEX	9
33122	BRACKET,ANGLED,BELT TENSIONER	7	7958	NUT,HEX	10
33123	GASKET	7	7958	NUT,HEX	34
33124	WASHER	8	33150	COUNTERWEIGHT,CAM	9
33124	WASHER	29	33152	SCREW,SET	10
33125	SCREW	8	33152	SCREW,SET	24
33125	SCREW,SHC	9	33152	SCREW,SET	29
13482	NUT,HEX	8	33153	SCREW	10
13482	NUT,HEX	9	33154	M16X40	10
13482	NUT,HEX	32	33155	SCREW	10
33127	ROD,THREADED	8	33156	SHAFT,TAMPING,ASSY	10
33127	ROD,THREADED	32	33157	KEY,24X9X80 130N	10
33128	KEY	8	33158	HOUSING,TAMPING SHAFT COLUMN	10
33128	KEY	9	33159	SPACER	10
33129	SCREW,HEX M8	8	33160	POST	11
33129	SCREW,HEX M8	12	33161	DOSING BOWL HALF	11
33129	SCREW,HEX M8	23	33162	TAMPING BASE	11
33129	SCREW,HEX M8	24	33163	SCREW,LEVELING,TAMPING HOUSING	11
33129	SCREW,HEX M8	25	33164	PIN,DOWEL	11
33129	SCREW,HEX M8	29	33165	SCREW	11
33130	SCREW,HEX	8	13494	SCREW	11
33130	SCREW,HEX	29	33167	SCREW,SET	11
33131	PLATE	8	33168	SCREW,SET	11
33132	BRACKET,CLAMPING,SORTING	8	33170	SCREW,SET	11
33134	LEVER,SEPARATION	9	33171	SCREW	11
33135	NUT,SQUARE	9	33172	HANDLE	11
33136	BLOCK,SEPARATION ADJUSTMENT	9	33173	UNIVERSAL JOINT	11
33137	ROD	9	33174	SCREW	11
33138	CAM, SEPARATION	3	33175	SCREW,LONGER	11
33138	CAM, SEPARATION	9	33176	PIN	11
33139	BRACKET,SEPARATION ADJUSTMENT	9	33177	HOUSING	11
33140	BRACKET,SEPARATION ADJ	9	33178	HOUSING	11
33141	BRACKET,FORK,SEPARATION	9	33179	GASKET	11
33142	SCREW,HEX	9	33180	STUD	11
33143	NUT,HEX	9	33181	BUSHING	11
33143	NUT,HEX	10	33183	SCREW	12
33143	NUT,HEX	12	33184	WASHER	12
33144	HANDLE	9	33184	WASHER	29
33145	SHAFT	9	33185	WASHER	12
33146	BUSHING	9	33186	STUD,THREADED M8	13
33147	BLOCK,SEPARATION,ADJ	9	33187	PLUG	12
31049	SCREW,HEX	9	33188	SHAFT,MAIN	1
31049	SCREW,HEX	18	33188	SHAFT,MAIN	9
31049	SCREW,HEX	19	33189	SCREW	12

IIM #	Description	Section	IIM #	Description	Section
33190	KEY	12	33237	SCREW,SHC M6	21.1
33191	O-RING	12	33237	SCREW,SHC M6	24
33192	PIN,DOWEL	12	33237	SCREW,SHC M6	25
33193	CONNECTOR	12	33237	SCREW,SHC M6	29
3761	SCREW	12	33237	SCREW,SHC M6	32
33195	SCREW	12	33238	O-RING	26
33196	MOTOR	12	33239	SPACER	25
33197	HUB,GEAR	12	33239	SPACER	26
33198	HOUSING	12	33240	SPRING SLEEVE	25
33199	BLOCK,CONNECTOR	12	33240	SPRING SLEEVE	26
33200	CUP,POWDER	12	33241	STRAIGHT PIN	25
33201	RING,CLAMP	12	33241	PIN M6	26
33202	RING	12	14349	SCREW	32
33203	PLATE,AUGER DRIVE BASE	12	14349	SCREW	33
33204	HOPPER,POWDER	13	33243	SCREW,SET	26
33205	SHAFT,DRIVE,POWDER AUGER	13	8111	SCREW,CHEESEHEAD M4	25
33206	SHAFT	13	8111	SCREW,CHEESEHEAD M4	26
33207	SCREW,SHC M6X50	14	33245	SCREW,FLAT M6	26
33207	SCREW,SHC M6X50	14.1	33246	BEARING HOUSING	25
33207	SCREW,SHC M6X50	33	33246	BEARING,SEPARATION SHAFT,TABLETOP	26
33209	HOUSING,LINEAR BEARING	14	33246	BEARING HOUSING	32
33209	HOUSING,LINEAR BEARING	14.1	33247	PLATE,MOUNTING,SEPARATION	26
33209	HOUSING,LINEAR BEARING	14.2	33249	PLATE,SUCTION SHOE	26
33209	HOUSING,LINEAR BEARING	33	33250	PLATAE,SEPARATION PIN	26
13652	SCREW,M10,EJECT,W/BLOWOUT BORE	14	33251	SHAFT,SEPARATION	25
13652	SCREW,M10,EJECT,W/BLOWOUT BORE	14.1	33251	SHAFT,SEPARATION	26
13652	SCREW,M10,EJECT,W/BLOWOUT BORE	14.2	33252	BUSHING	25
33211	BLOCK,GUIDE,BEARING	14	33252	BUSHING	26
33211	BLOCK,GUIDE,BEARING	14.1	33253	SPACER	25
33211	BLOCK,GUIDE,BEARING	14.2	33253	SPACER	26
33215	SCREW,SHC	20	33254	O-RING	25
33217	HOUSING	15	33254	O-RING	26
33218	HOUSING,TURRET	15	33255	BUSHING	25
33219	CENTERCONE FLANGE	15	33255	BUSHING	26
33219	CENTERCONE FLANGE	34	33257	BRACKET,ANGLE,BEARING GUIDE,149L	32
33220	DEFLECTOR,POWDER,TAMPING BASE	15	33257	BRACKET,ANGLE,BEARING GUIDE,149L	33
33222	CONNECTOR,PUSH IN,6MM TO G1/4	23	32307	SCREW,HEX,M8	30
33224	SCREW	23	33265	SIGHT GLASS,CAP HOP 50mm	30
33225	NUT	23	33267	TUBE	30
33226	SCREW,SHC	23	13505	WASHER M16	2
33227	VALVE	23	13505	WASHER M16	33
33233	BRACKET,ANGLED,MOUNTING	23	13429	PIN,DOWEL	32
33235	PIN,DOWEL	26	13429	PIN,DOWEL	33
33237	SCREW,SHC M6	21	7570	SCREW	18

IIM #	Description	Section	IIM #	Description	Section
7570	SCREW	19	33310	BLOCK,UPPER CLOSING,CAPS STOP	21.1
7570	SCREW	21	33311	BLOCK,MOUNTING,UP CLOSING HOUSING	21
7570	SCREW	21.1	33311	BLOCK,MOUNTING,UP CLOSING HOUSING	21.1
7570	SCREW	37	33312	SCREW	21
33273	INSERT,THREADED	33	33312	SCREW	21.1
33274	ROD,THREADED	33	33313	GUIDE	21
33276	HOUSING,MANIFOLD,FCE VACUUM TAKEAWAY	31	33313	GUIDE	21.1
33277	SCREW	31	33314	SPRING	21
33278	SCREW	33	33314	SPRING	21.1
33279	SPACER	33	33315	PIN,DOWEL	22
33280	FAULTY CAPSULE EJECTION 12CT LEVER ARM	33	33317	SCREW	18
33282	SCREW	31	33317	SCREW	19
33282	SCREW	36	33318	PLATE,SPRING FINGER CAPTURE,11CT	19
33282	SCREW	36.1	33319	PLATE,SPRNG FINGER CAPTURE,11CT,SZ4/5	18
33282	SCREW	37	33319	PLATE,SPRNG FINGER CAPTURE,11CT,SZ4/5	19
33283	WASHER	15	33320	BUSHING	18
33283	WASHER	34	33320	BUSHING	19
33284	SCREW	34	33321	SCREW	18
33285	DOSING BOWL,SIDERING	34	33321	SCREW	19
33286	CENTERCONE FLANGE	34	33322	SCREW,CHEESEHEAD	18
33287	AXIS FOR WIPER CONE	34	33322	SCREW,CHEESEHEAD	19
33288	SHIM	25	33323	MOUTHPIECE,MAGAZINE,11CT	19
33288	SHIM	34	33324	BLOCK,REAR MOUNT,ALIGN,MAG11CT	19
33289	BEARING	34	33325	SCREW,M8	36
33290	SCREW	34	33325	SCREW	36.1
33291	O-RING	34	33326	PIN	36.1
33292	PIN,DOWEL	34	33327	SCREW	36
33293	HOLDER,SENSOR	34	33327	SCREW	36.1
33295	TUBE,POWDER,TRANSFER	34	33331	SCREW	36
33296	POST,M6	34	33331	SCREW	36.1
33297	SIGHT GLASS,LEVEL SENSOR PLATE	34	33332	SCREW,EJECT HOUSING,FEMALE	36
33301	PLATE,LEVEL SENSOR,OUTER	34	33332	SCREW	36.1
33303	PLATE,TAMPING PIN RETAINER 11CT	35	33334	SPACER,BLOCK,EJECTION,SZ000-2	36
33305	SCREW	35	33336	SCREW	37
33307	LOWER CLOSING SHAFT	21	33339	BLOCK,MOUNTING,CLEAINING STATION	37
33307	SHAFT FOR LOWER CLOSING PLATE	21.1	33340	STUD,SET SCREW	37
33308	PIN	18	33341	SCREW	24
33308	PIN	19	33342	SCREW	24
33308	PIN	37	33342	SCREW	28
33309	LOWER CLOSING HEAD	21	33343	SCREW,SHC	24
33309	LOW CLOSING HEAD	21.1			
33310	BLOCK,UPPER CLOSING,CAPS STOP	21			

IIM #	Description	Section	IIM #	Description	Section
33343	SCREW,SHC	29	33398	CONNECTOR	23
33344	SCREW,SHC	24	33400	NUT M12	33
33344	SCREW,SHC	29	33401	NUT	33
33345	SCREW	24	33403	RETAINING SCREW	35
33346	SCREW	24	33404	SCREW,HEX M6	21
33346	SCREW	29	33406	SCREW FEMALE	21
33347	WASHER	24	33406	HAND KNOB	21.1
33347	WASHER	28	33407	PIN,DOWEL	21
33348	SCREW	24	33410	SPACER,BLOCK,EJECTION, SZ0-4	36
33348	SCREW	28	33410	SPACER	36.1
33349	O-RING	29	33586	PIN	36
33350	SCREW	24	33586	PIN	36.1
33350	SCREW	29	33657	SCREW	27
33351	HOLDER,PLUNGER	24	33735	BLOCK,REAR MOUNTING,ALIGN,MAG,T	18
33351	HOLDER,PLUNGER	28	33404	SCREW,HEX M6	21
33352	HOUSING	24	33406	SCREW FEMALE	21
33352	HOUSING	29	33406	HAND KNOB	21.1
33353	COVER,HOUSING SORTING	24	33407	PIN,DOWEL	21
33354	HOUSING,FACE SORTING	24	33410	SPACER,BLOCK,EJECTION, SZ0-4	36
33355	PLATE,BASE,SORTING,11CT	24	33410	SPACER	36.1
33356	BRACKET,MAG HOUSING	24	33586	PIN	36
33356	BRACKET,MAG HOUSING	29	33586	PIN	36.1
33358	O-RING	24	33657	SCREW	27
33358	O-RING	29	33735	BLOCK,REAR MOUNTING, ALIGN,MAG,T	18
33359	PLUNGER,SPRING LOADED	24	34071	SEPARATION PIN,CONCAVE	25
33359	PLUNGER,SPRING LOADED	28	34072	LOW CLOS BLOCK, ALUM	22
33360	BRACKET,MOUNTING,MAIN DRIVE	3	34073	LOW CLOS BLOCK, SST	22
33361	TURRET,SEGMENT	7	34098	BUFFER PLATE	18
33362	COVER	7	34119	PIN,THREADED	22
33363	WASHER	8	34120	MAGAZINE LIFT BRACKET	27
33366	O-RING	15	34121	MAGAZINE LIFT SHAFT	27
33370	BLOCK,UPPER CLOSING	21	34122	MAGAZINE LIFT ARM	27
33370	BLOCK,UPPER CLOSING	21.1	35275	GUIDE RING	34
33371	ASSY,KNOB,STUD	21	34177	CLEANING STATION CLOVER	37
33371	ASSY,KNOB,STUD	21.1	34178	UPPER CLEANING MANIFOLD	37
33372	ASSY,KNOB,STUD	13	34179	BASE CLEANING MANIFOLD	37
33372	HAND KNOB ASSY	13	34229	FCE ARM ASSY	33
33372	ASSY,KNOB,STUD	21	34238	SCRAPER	34
33372	ASSY,KNOB,STUD	21.1	34251	KNOB,ASSY DOSING DISC LIFT	17
33374	PLATE,TOP,SORTING,11CT	24	34253	SUCTION SHOE,SEPARATION,10CT	25
33379	PLATE,EJECT DRIVE	14.1	34255	SCREW	33
13962	MOTOR+GEARBOX,MAIN DRIVE	1	34309	FCE BLOCK 9CT	32
33382	SCREW,SHC	37	34310	UPGRADED 9CT FCE ASSY	32
33397	O-RING	23	34311	SHOE,9CT,FCE ALUM	32

IIM #	Description	Section	IIM #	Description	Section
34313	FCE 9CT DRIVE SHAFT	32	34814	SCREW,SHC	25
34314	SHAFT ASSY,9CT FCE	32	34815	PLATE,SUCTION SHOE	25
34315	FCE 9CT HEAD PLATE	32	34816	BLOCK,SEPARATION 10CT	25
34321	BASE,BLOCK,9CT,FCE	32	34817	SCREW	29
34356	MAGAZINE MOUNT ASSY	27	34818	COVER,HOPPER,CAPSULE 3005	30
34357	MAGAZINE MOUNT BRACKET	27	34819	HOPPER,CAPSULE 3005	30
34358	MAGAZINE MOUNT SHAFT	27	34820	GATE,FLOW CONTROL,HOPPER,CAPSULE	30
34447	FCE CAM	3	34821	BASE,HOPPER,CAPSULE	30
34447	FCE CAM	31	34822	KNOB	30
34596	EJECTION BOOMERANG	36.1	34823	COVER,FCE VACUUM FLOW CONTROL	31
34601	PLATE,EJECT DRIVE	14	34824	TUBE,TAKE AWAY,FCE	31
34612	SCREW,HEX,INTEGRAL WASHER,M6	36	34825	PIN,PIVOT,9CT FCE LEVER ARM	32
34613	GUARD,SORTING	29	34826	SCREW,HEX	32
34614	PLATE,BASE,SORTING STATION,10CT	29	34827	BLOCK,MOUNT,FCE 9CT LEVER ARM	32
34615	PLATE,TOP,SORTING STATION,10CT,3005	29	34828	WASHER	32
34616	PLATE,FRONT,SORTING HOUSING,10CT,3005	29	34828	WASHER	33
34617	POWDER TRANSFER BAR	34	34829	SCREW	34
34634	ASSY,SHAFT,CAP SEPARATION,11CT	26	34830	PIN,DOWEL,DOSING DISC ALIGNMENT	34
34635	BOLT,SHOULDER	32	34831	SCREW	34
34637	FCE DRIVE SHAFT ASSY	33	34832	POST,MOUNTING,POWDER PLATE	34
34640	EJECTION COVER, NEW	36	34833	PATE,MOUNTING	34
34640	EJECTION COVER, NEW	36.1	34834	BLOCK,TRANSFER,COVER	35
34651	EJECTION COVER, OLD	36.1	34835	PLATE,TAMPING PIN HOLD,10CT	35
34654	TRANSFER BLOCK INSIDE GUIDE	35	34836	BLOCK,TAMPING ADJ 21CT	35
34655	TAMPING PIN RETAINER, 10CT	35	34837	SPACER,BLOCK,EJECTION,SZ0-4	36
34672	PLATE,TAMPING PIN RETAINER 10 CT	21.1	34837	SPACER,BLOCK,EJECTION	36.1
34631	LOW CLOSING ASSY POS.7	21	34838	TUBE,DISCHARGE,EJETION	36
34678	FCE DRIVE SHAFT HEAD	33	34838	TUBE,DISCHARGE,EJETION 3005	36.1
34679	FCE DRIVE SHAFT	33	34839	HOUSING,BASE,EJECTION	36
34680	LEVER ARM,FCE 9CT	32	34839	HOUSING,BASE,EJECTION STATION 3005	36.1
34728	COVER,CAPSULE BIN,3005	30	34840	SCREW	36
34753	CONVERSION BLOCK	14.1	34840	SCREW	36.1
34793	PIN,SEPARATION	26	34841	CHUTE,EJECTION HOUSING,INCLINE	36
34806	ADAPTER,VACUUM	23	34841	CHUTE,EJECTION HOUSING,INCLINE	36.1
34807	BOOMERANG,EJECTION& CLEANING,42CT	36.1	34842	PIN,DOWEL	36
34808	BRACKET,VACUUM,HOUSING	23	34842	PIN,DOWEL	36.1
34809	HOUSING,FILTER	23	34843	HOUSING,TOP,EJECTION STATION,SZ0-4	36
34810	ADAPTER,FILTER	23	34843	HOUSING,TOP,EJECTION STATION 3005	36.1
34811	BLOCK,SEPARATION SHAFT	25	34844	PIN,DOWEL	36
34812	BLOCK,ANGLED	25	34844	PIN,DOWEL	36.1
34813	BRACKET,SEPARATION SHAFT	25	34845	HOUSING,TOP,EJECTION STATION SZ000-2	36
			34845	HOUSING,TOP,EJECTION STATION	36.1

