TOC METER ANALYZER



TOTAL ORGANIC CARBON (TOC)

Organic compounds – present in almost all types of water ...

Organic compounds are found in almost all types of water – from natural and treated drinking water to process water, cooling water, and water used in pharmaceuticals and food production.



... and a challenge in many industrial processes

Too much organic contamination in the water interferes with many industrial processes. For example, an excess of organic matter can foster microbiological growth or, when disinfecting drinking water, encourage the presence of undesirable byproducts. On the other hand, there are numerous processes in the chemical and galvanic industries in which water is mixed with organic additives. In order to control and monitor these processes, it is important to measure the amount of organic substances in the water.

TOC – an important sum parameter

Given the huge numbers of organic compounds in water, it is practically impossible to identify and measure each one individually. Instead of analyzing individual substances, a fast and precise way to rate water quality is to measure sum parameters – this is especially helpful in the case of online monitoring. Measuring the total organic carbon (TOC) is particularly important for the evaluation of the total organic contents. The advantages of TOC analysis include the high levels of accuracy and precision that can be achieved, even with small sample amounts, plus the ease with which the process can be automated.





- In many industry sectors, measuring and checking the TOC is an essential factor in making processes more efficient and reducing costs as a result.
- Monitoring the TOC is a key part of the correct treatment of wastewater and is also crucial in ensuring compliance with the organic load limits involved in wastewater treatment.
- In the field of power plant analysis, the TOC value provides information on the quality of the boiler feed water. Following the purification of condensate/make-up water, the TOC value is used to determine whether the condensate/make-up water can be fed back into the water-steam line.
- Run-off and storm water from chemical and petrochemical plants as well as airports can contain high concentrations of organic compounds. Monitoring the TOC value at collection points makes it easier to decide whether the streams require post-treatment or whether they can be fed into the outfall or the communal sewage system.

Industry sectors

- Chemicals
- Pharmaceuticals
- Food & beverage
- Automotive
- Oil & gas
- Power & energy
- Petrochemicals
- Pulp & paper
- Airports
- Environmental monitoring

Sample types

- Drinking water
- Surface water
- Process control
- Boiler feed water/condensate
- Cooling water
- Run-off/storm water
- Wastewater

Measuring TOC continuously online is the perfect solution for monitoring contamination and discharges. The TOC Analyzer measures total organic carbon in liquid samples using the method of UV persulfate oxidation with subsequent carbon dioxide detection by nondispersive infrared absorption (NDIR). The analyzer can measure TOC in liquid samples ranging from 0–5 mg/L to 20,000 mg/L. The method conforms to EPA, DIN, CE, ASTM, and NAMUR regulations as well as meeting the requirements of ISO and EN directives.

Safe operation in case of sample loss

The fast loop reservoir has a floating level sensor. If no sample reaches the reservoir for more than a preset time, the analyzer switches automatically to standby mode. As soon as the sample flow restarts, the analyzer switches back to the analysis cycle automatically. Air bubbles are removed in the reservoir before the sample enters the analyzer.

Digital flowmeter

Unlike traditional analyzers where the flow is controlled by a glass tube rotameter, the carrier gas flow is controlled digitally and is displayed in cm³/min. The flow is monitored and in the case of an abnormal value such as a line blockage, the analyzer stops automatically and displays a «low carrier flow» message.



Valve-free sample line

Samples are taken and reagents are added via the peristaltic pumps eliminating valves which risk being blocked. The autoclean, autocalibration, and autovalidation functions guarantee correct, reliable values that can be reproduced at any time without the need for manual intervention.

Dual compartment enclosure

The analyzer consists of two separate housing compartments in order to separate the electronics from the wet part.

Analysis process

The sample first is acidified and then sparged to remove inorganic carbon. The remaining liquid is mixed with sodium persulfate and digested by two high-performance reactors. The resulting CO₂ is then stripped from the liquid and, after drying, its concentration is measured by a NDIR analyzer.

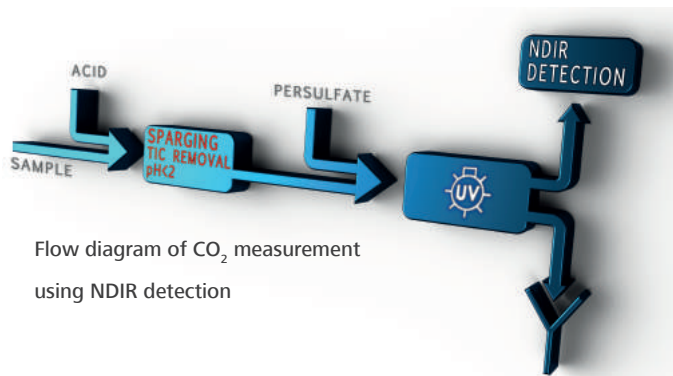

Flow diagram of CO₂ measurement using NDIR detection

Integrated carrier gas

An internal air compressor produces the carrier gas for the oxidation and detection stages. The air is purified using an internal soda lime filter which means that there is no need for external air treatment or a compressed air supply, as in traditional analyzers.

Autoclean

This function uses a dedicated peristaltic pump to clean the liquid lines of the analyzer, the sample line, and the external reservoir.

Separate lines for stripping gas and carrier gas

There are two separate gas lines, each with its own compressor. One is intended for the stripping gas for the TIC (total inorganic carbon) and one for the carrier gas (automatically monitored by a digital flowmeter).

Automatic ZEROGAS checks

The ZEROGAS value is expressed in ppm and specifies the residual CO₂ concentration value in the carrier gas (ambient air filtered through a soda lime filter). During a ZEROGAS cycle, the pumps and UV lamps are switched off and the carrier gas passes through all the wet cells to the IR detector. The detected CO₂ concentration is stored in the analyzer as the ZEROGAS value. A ZEROGAS cycle can be started manually or automatically at a time and interval selected by the operator. If the ZEROGAS value exceeds a certain preset limit, the alarm «ZEROGAS too high» will be activated and the analyzer will stop.



Materials used in the analyzer

All materials used are chosen for their long life and reliability. The design uses the minimum number of fittings. All of the materials used are resistant to the corrosive liquids used during operation.

TOC or TC

The Analyzer is also available as a total carbon (TC) analyzer. Here the step of sparging the acidified sample is omitted. Along with a high volume external pump, this offers faster response times when the total inorganic carbon (TIC) in the sample is considered insignificant.



SIMPLE OPERATION - FULL CONTROL

The user interface is a touchscreen located on the front of the analyzer. All output/input data, status information, alarms, and fault conditions are shown. Simply pressing the touchscreen buttons gives access to commands and settings; access to the system configuration and timings is protected by a password.

Main screen

During normal operation, the main screen shows a graphical display of the trend in measured concentration. Buttons are provided to select the operating modes and there are indicators of statuses and alarms.



Main screen with process values

Simply press on the main screen to obtain the status of analyzer, sample, and relay; carrier gas flow, reagent fill levels, and measured CO₂ concentrations, and last validation result. This provides all the information needed to check the analyzer is operating correctly.



Integrated data logger

Tapping on the result graph opens a notepad where the day's results are recorded at 3-minute intervals. Results for the last 30 days are saved in the instrument at 15-minute intervals and can be downloaded onto a USB stick at any time for evaluation on a PC.



Calibration page

After logging into Advanced mode, the user can access the carrier gas (ZEROGAS), liquid zero, and calibration functions. An autocalibration cycle can be activated according to the times and intervals set by the user on the timing page.

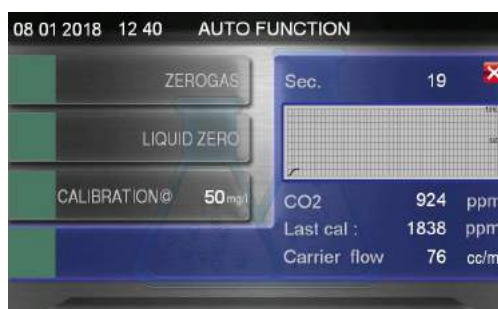

Timing page

The timing page can also be called up in Advanced mode. This page can be used to set timed automatic checks on the ZEROGAS, control the extra relay, set conditioning parameters, and schedule the selected automatic function.



TOC configuration

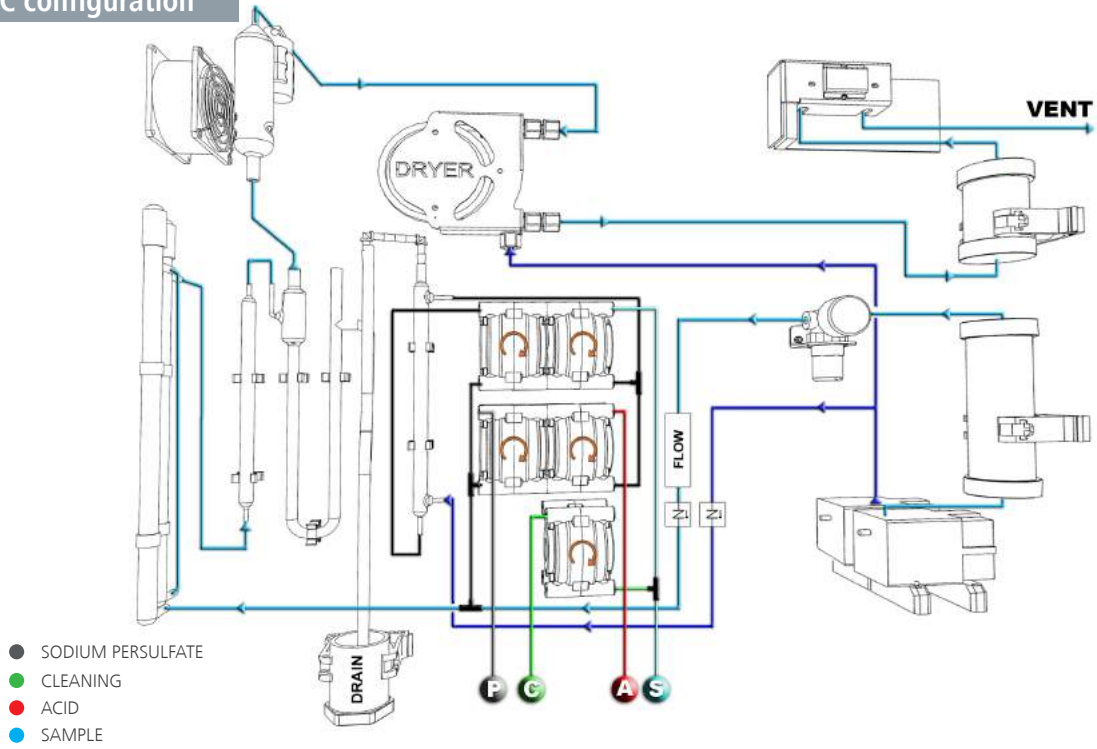

TC configuration

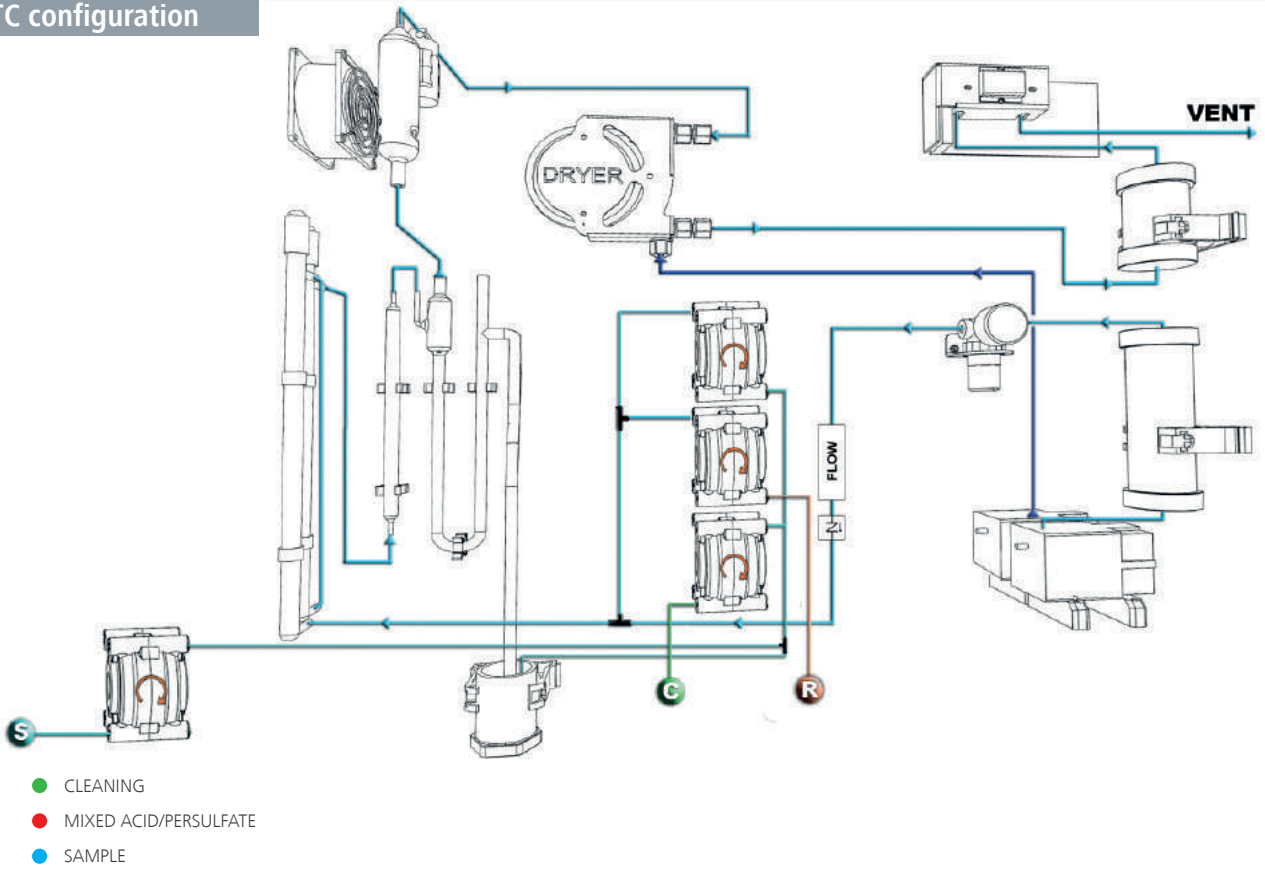

TOC DIMENSIONAL DRAWINGS

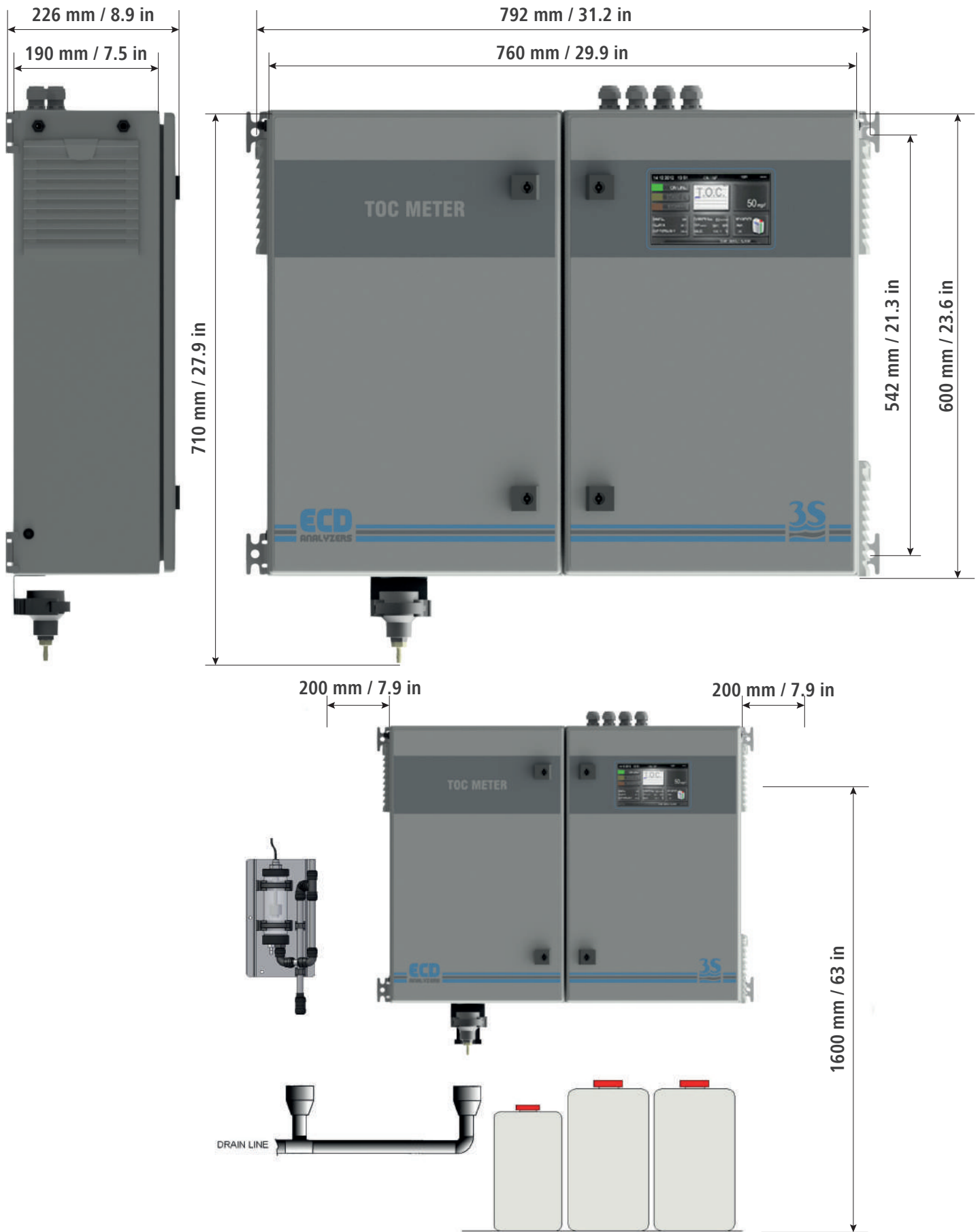

FAST LOOP RESERVOIR

The fast loop reservoir allows a fast circulation of the sample coming from the sampling point or from the optional filtration unit. Inside the fast reservoir, the sample is at atmospheric pressure allowing a constant delivery of the sample without any possible overpressure.

In addition to this, the fast-loop reservoir is a useful extra quantity of sample to avoid unnecessary fault alarms in case of short loss of sample as well as to eliminate air bubbles from sample coming the sample line or caused by the cleaning cycle of the optional filtration unit.

The stainless steel drain tubing keeps a constant water level inside the container and allows a proper sample circulation to avoid suspended solids accumulation.

The sample flow should be adjusted to have the complete sample overflow through the stainless steel tube, U shaped. A small hole at the stainless steel tubing allows to empty the fast-loop reservoir for cleaning purposes just with the finger pressure.

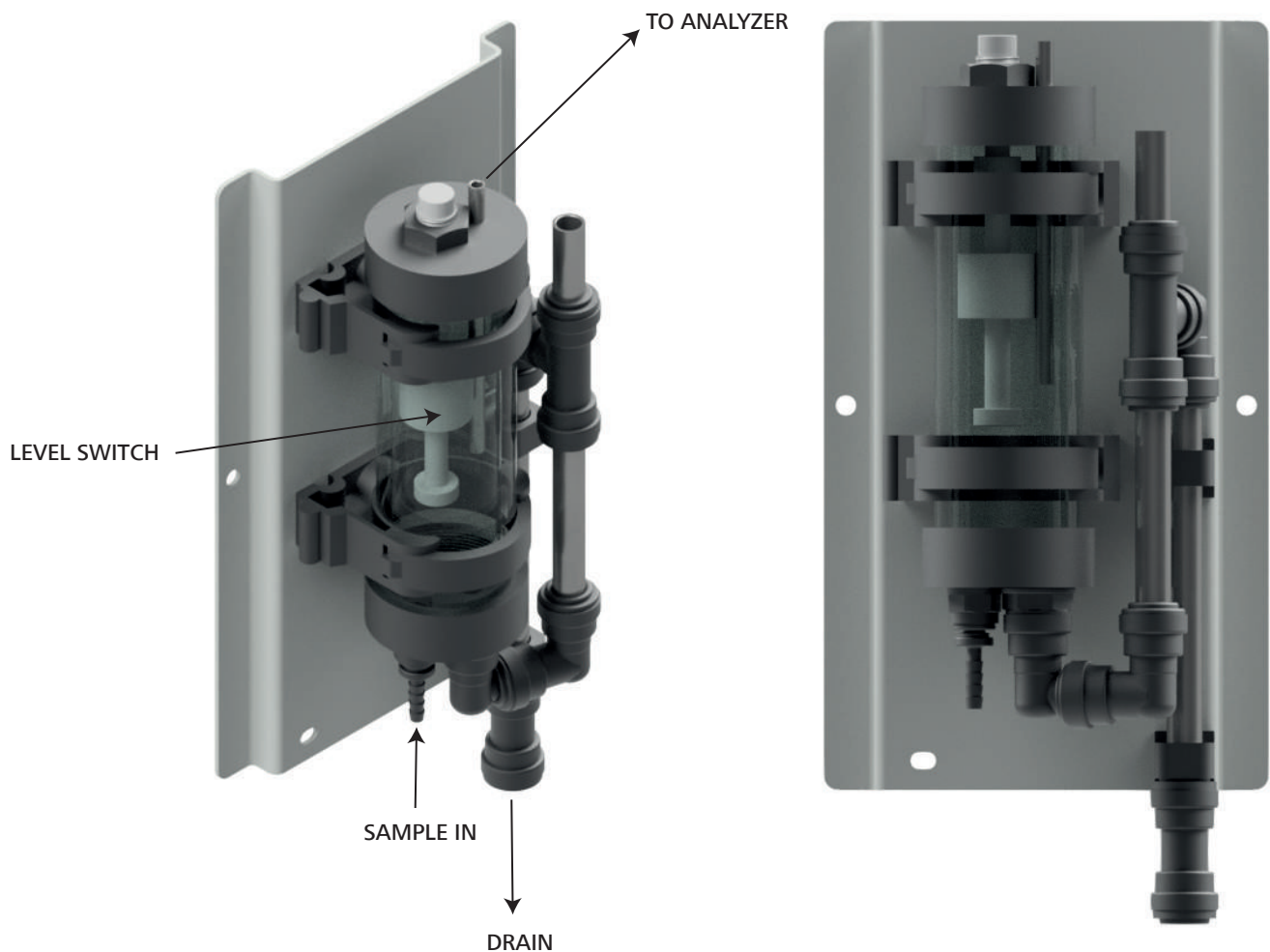

SPECIFICATIONS AND ACCESSORIES

Analyte	Total Organic Carbon (TOC), Total Carbon (TC)
Method	For TOC measurements, inorganic carbon is removed by acidification and sparging; this is followed by UV-promoted persulfate oxidation. This process oxidizes the total organic carbon into carbon dioxide which is measured in a nondispersive infrared (NDIR) analyzer. For TC measurements, the sparging step is omitted.
Range	0–5 mg/L to 20,000 mg/L
Measurement type	Continuous
Lower determination limit	0.2 mg/L (for range 0-5 mg/L using nitrogen as carrier gas)
Accuracy	± 2% of full scale nondiluted, ± 4% of full scale diluted ranges
Response time	From 6 minutes, depending on range
Ambient temperature	5-40°C / 41 - 104°F
Sample temperature	2–70°C / 36 - 158°F
Sample inlet pressure	Pressureless from overflow vessel (Fast Loop Reservoir)
User interface	Color touchscreen
Data logger	Integrated, data download via USB flash drive (USB stick)
Size	760 × 600 × 210 mm / 29.9 x 23.6 x 8.3 in
Weight	37 kg / 81.57 lbs (approx. depending on range)
Power supply	115 or 230 VAC 50/60 Hz, 350 VA (115 VAC), 250 VA (230 VAC)
Carrier gas	Air purifier integrated, supplied by an internal compressor. N ₂ or CO ₂ free air supply can be used as an option
Reagents	Phosphoric acid and sodium persulfate (approximately 10 L/month for continuous operation)
Analog outputs	2 × 4–20 mA outputs for measured data
Alarms	2 SPDT contacts. Relay A is programmable – online, offline, loss of sample, result alarm, validation alarm, reagent alarm, calibration alarm. Relay B is for the instrument fault alarm
Extra relay	Programmable for external operations
Digital input	Remote start/stop
Autoclean, autocalibration, autovalidation functions	Can be selected using the dedicated peristaltic pump
Dual channel	Dual channel integrated
Dual range (low/high)	Switches sample to an external dilutor for a higher range once a set-point is passed
Factor	Result multiplication factor, e.g., for converting TOC to equivalent COD value
Protection class	IP54 - NEMA 3
Conformity	EN 610004-2, EN 610004-4, C 46-022, EN 55022, EN 61326 (electromagnetic compatibility)

ACCESSORIES AVAILBLE

Fast loop reservoir	Maintains a constant sample flow and switches analyzer to standby in case of insufficient flow. As soon as the sample flow restarts, the measurement is resumed.
External diluters	Options of 2x to 40x dilution of one or two sample streams using 1 motor with dual pump heads or 2 motors with single pump head.
Filtration unit	Self-cleaning, at user selectable intervals and cleaning period