



## Level and Flow Measurement

# Welcome:

Pulsar® Process Measurement has, since 1997, led the way in non-contacting ultrasonic level and flow measurement technology.

As a pioneer of digital echo processing through patented DATEM software, and an innovative manufacturer of the new generation of ultrasonic devices, Pulsar has taken the measurement technique into new areas, new applications where non-contacting measurement could not previously have been contemplated. In doing so, Pulsar has developed a superb product range which allows engineers to select exactly the instrument to meet their needs, whether that is for sophisticated monitoring and control of a sump or lift station with several pumps; high accuracy, high stability open channel flow measurement; remote contents monitoring of a multitude of sites with SMS messaging protocol; distributed control of a process plant or just for simple alarms on a single tank.

Reliable, well engineered point level measurement instruments, process protection devices and the exceptional Sludge Finder 2 interface monitor complete the range, along with software and accessories to help you get the best from the equipment.

We pride ourselves on our attention to detail and customer service. From your first contact with our office through to final set up of your equipment, Pulsar's staff are dedicated to the success of your project, offering advice, consultation and support to ensure that you get the best possible results.

Pulsar's development was recognised with the award of the prestigious Queen's Award for Enterprise: Export Achievement 2009. You can buy Pulsar equipment anywhere in the world secure in the knowledge that it is supported by probably the best distributor network in the industry.



MALVERN HQ



U.S.A. HQ

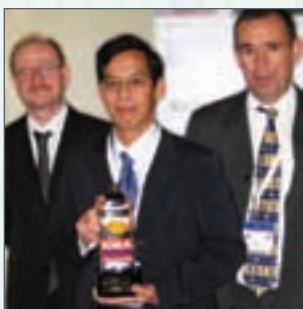

## iDEA Award

Pulsar engineers won this prestigious iDEA award in 2008 for reducing design cycle time – bringing new innovation quickly to market so that customers can quickly gain the benefit of new technology.



## Queens Award

The Queen's Awards for Enterprise have been described as 'the knighthoods of business'. Pulsar were honoured in 2009 in the 'Export Achievement' category, recognising the way that Pulsar have always seen global business as central to their development, building partnerships with customers and distributors throughout the world.



# Contents:

Description	Page	
Continuous Level Measurement:	04	■
dB Transducers: Standard Range and Threaded Range	06-10	■
Accessories and Brackets:	11-13	■
DATEM Software:	14	■
Ultra Range: Introduction	15	■
Ultra 3/5/TWIN:	16-18	■
Ultra Wizard:	19	■
Ultra Range: Product Comparison	20-21	■
Ultra PC Software:	22	■
Applications: Pump/Open Channel/Differential /Volume	23-24	■
Specialist Ultrasonic Range: Introduction	25	■
FlowCERT/DUET/Speedy:	26-28	■
Speedy Interface:	29	■
FlowCERT/DUET/Speedy: Technical Specification	30	■
Zenith: + Technical Specification	31-33	■
Quantum: + Technical Specification & Product comparison	34-36	■
Blackbox: Introduction	37	■
Blackbox 130/133/134/135/136:	38	■
Blackbox Calibration:	39	■
Blackbox Display:	40	■
Blackbox Modem/136/136 Level CSO: + Technical Specification	41-45	■
IMP: Introduction	46	■
IMP: +Technical Specification	47-48	■
IMP I.S.: +Technical Specification	49-50	■
Sludge Finder 2: Introduction	51	■
Sludge Finder 2: Introduction + Technical Specification	52-55	■
200 Vibrating Probes: + Technical Specification	56-57	■
300 Rotating Paddles: + Technical Specification	58-59	■
700 Pressure Transducer: + Technical Specification	60-61	■
800 Float Switches: + Technical Specification	62-63	■
Pulsar Guard 2010: + Technical Specification	64-65	■
Contact Details:	66-67	■



# Continuous Level Measurement:

There are many good reasons for monitoring and controlling level and flow of materials, from simple stock control through to sophisticated control of critical process levels and measurement of flows for environmental monitoring.



Just as there are many good reasons for measuring materials, there are good reasons for using non-contacting techniques – in solids, contamination may be an issue, a probe can wear out, or break, or materials can stick to the probe and give false readings. In liquid applications, the same problems may be faced as in solids, with the added complications of agitators, foam, or fumes. A good non-contacting no maintenance system is the ideal answer.

Ultrasonic measurement is a 'time of flight' technique where a high-frequency sound wave at a specific frequency is generated by exciting a piezoelectric crystal, usually positioned above the material level to be measured. This sound wave is reflected from the target material and re-excites the crystal, providing a signal that is analysed by a "transceiver". Knowing the speed of sound, the time delay between excitation and re-excitation is translated into a distance. Often, this basic data is displayed as something more meaningful to the user, for example a measurement of level or volume based on the overall dimensions and shape of the vessel.



**IMERYS**  
WITH DATEM, EVEN  
MEASUREMENTS  
THROUGH IRON GRIDS  
LIKE THIS ARE POSSIBLE

Ultrasonic measurement has been around for a long time - the early systems came into regular use in the 1970's and 80's. Before the rise of digital signal processing these early units were analogue devices, and while ingenious, were very difficult to set up, calibrate and work with, sometimes having problems from the effects of objects in the 'beam angle' producing false echoes and false measurements. The major breakthrough came with the development of digital echo processing, of which types Pulsar's DATEM system leads the way.

## DATEM – Digital Adaptive Tracking of Echo Movement

Pulsar Process Measurement's DATEM system identifies the correct echo using a range of parameters, then tracks it, so no matter what competing echoes there are in the vessel, the correct echo is followed throughout. The system will even follow material level through grids or gratings, something that would have been unthinkable using the older analogue systems, or even the earlier digital algorithms, which still relied on the size of the echo or whether it was "first". The 'beam angle', so important to early systems, is now almost irrelevant despite echoes from significant obstructions.

**TRUE ECHO SHOWN  
BY THE BLUE LINE**

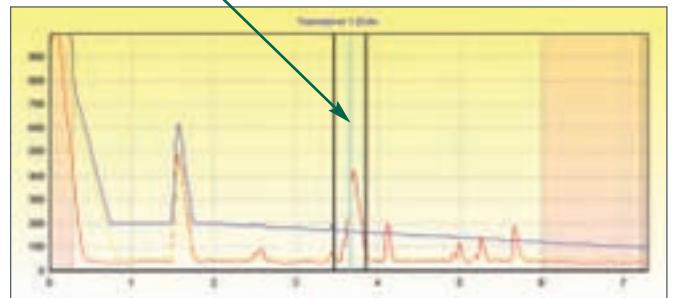

**ECHO TRACE**  
USING Pulsar SOFTWARE, IT IS POSSIBLE TO SEE  
HOW THE SYSTEM 'ZEROES IN' ON THE TRUE ECHO  
FOR ULTRA-RELIABLE PERFORMANCE.

# pulsar

## Transducers



### Standard Range

page 06

A range of compact high acoustic output, non contacting transducers are designed for liquids or solids level measurement use. All have ATEX EEx m as standard for use in zone 1 flammable atmospheres.



### Threaded Range

page 09

These incorporate the performance features of the standard products, but additionally offer a front thread mount option to suit threaded nozzles or flanged tank entries.



### Accessories

page 11

Various transducer options can be provided to suit specific applications, such as submergence shields, foam faced transducers, sanitary flanges, blind flanges and a choice of transducer mounting brackets.

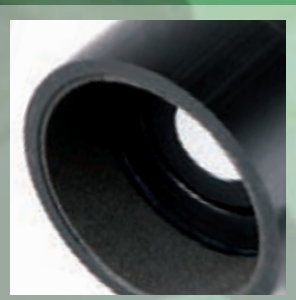

# Transducers:

## Standard Range

### Features

- Encapsulated ATEX (EEx m) for zones 1 and 2 as standard
- On NPT threaded versions, FM Class I, Div 1, Group A, B, C and D. Class II, Div 1, Group E, F and G. Class III.
- I.S. ATEX (EEx ia) for zone 0 (option)
- Integral temperature compensation
- Narrow beam angles
- Robust IP 68
- PZT ceramic transducer element
- Standard 2 or 3 core screened cable extensions to 1000m
- High acoustic power output
- Patented

Pulsar's main dB series of non contact ultrasonic transducers offer compact, robust measurement and an innovative approach to transducer design. Previously, users had a choice between high-voltage, frequency dependent transducers that were susceptible to electrical noise and needed special, protected interconnecting cables, and weak, low-power transducers that had good hazardous area performance but performed poorly in any but the simplest application.

The dB range has changed all that, creating a compact, low power transducer design that can be I.S. certified and uses standard interconnecting cables, yet produces extremely high acoustic power to give exceptional results in a wide variety of challenging situations.

Team a dB transducer with any of Pulsar's Ultra, FlowCERT, Zenith, Quantum or Blackbox control

units to create the perfect solution for your application. All transducers have flammable atmosphere approval as standard.

Standard transducer bodies are made from Valox 357 PBT with a special foam radiating face. Some are available with both body and sealed front face in PVDF for corrosive applications.

(all beam angles defined as, -3dB or half power inclusive)

#### **dB3 – short range solids and liquids measurement**

Range – 125mm – 3m, 125kHz, 19mm diameter radiating face, <10° beam angle.

All dB3 versions are fitted with a shallow drip shield.

#### **dB6 – short range solids and liquids measurement**

Range – 300mm – 6m, 75kHz, 30mm diameter radiating face, <10° beam angle.

#### **dB6S – short deadband version, solids and liquids measurement**

Range 200mm – 6m, at 50kHz, 45mm radiating face, <10° beam angle.

#### **dB10 – solids, powders and liquids measurement**

Range – 300mm – 10m, 50kHz, 45mm diameter radiating face, <10° beam angle.

#### **dB15 – narrow beam transducer for solids, powders and liquids**

Range – 500mm – 15m, 41kHz, 60mm diameter radiating face, <8° beam angle.

#### **dB25 – narrow beam, mid-range transducer for solids, powders and liquids**

Range – 600mm – 25m, 30kHz, 78mm diameter radiating face, <6° beam angle.

#### **dB40 – narrow beam, long range transducer for solids, powders and liquids**

Range – 1.2 – 40m, 20kHz, 160mm diameter radiating face, <5° beam angle.

#### **dB50 – narrow beam, long range transducer for solids, powders and liquids**

Range – 2 – 50m, 20kHz, 160mm diameter radiating face, <5° beam angle.

*dB50 for use with modified Ultra 3 & Ultra 5 only. dB50 not ATEX approved*



ALL BEAM ANGLES ARE INCLUSIVE, BUT GIVE AN EFFECTIVE BEAM ANGLE OF <3 DEGREES ON OUR CONTROLLERS. RANGE ON POWDERS AND SOLIDS DEPENDS ON APPLICATION.

# Transducers:

## Flanged Transducers

### Flanged transducers

Flange options are available for dB3, dB6, dB10 and dB15 transducers, ANSI or DIN specification, all featuring full PTFE coating on the process wetted side. Various flange sizes are available. Maximum vessel pressure on flanges is 0.5bar (7psi). See technical specifications for more details. These incorporate the performance features of the standard products, but additionally offer a front thread mount option to suit threaded nozzles or flanged tank entries.

These integral flange options are available with the standard family of transducers, up to the dB15 size.

### Features

- Full PTFE face on flange
- ATEX and optional FM flammable atmosphere units
- I.S. Intrinsically Safe versions available
- Rugged construction and IP68



UNDERSIDE OF THE FLANGED TRANSDUCER

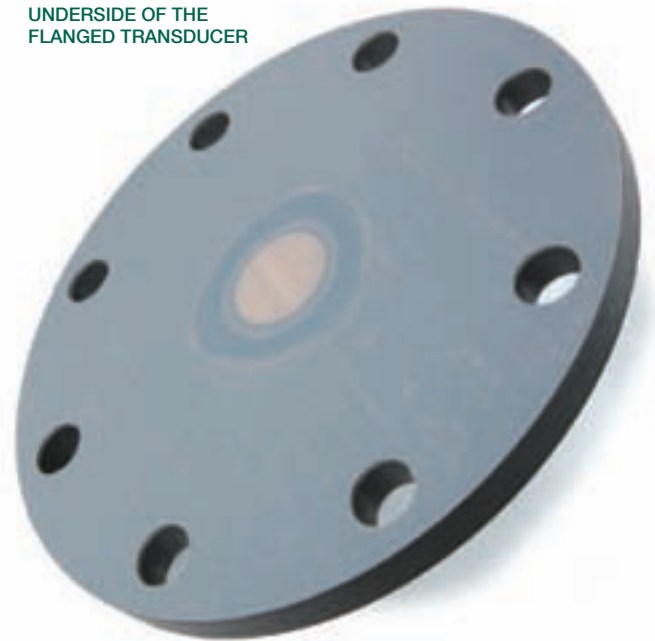

FLANGED TRANSDUCERS SHOWN ON TANKS



# Transducer Options:



## Foam Face

A foam faced option is available for all the standard range transducers to provide more acoustic power output in dry, dusty environments. This higher acoustic power output increases return echo strength in these dry applications. Not available on dB3 versions.



## Submergence Shield

A shield can be fitted to keep the transducer face clean and dry in applications at risk of submergence. In case of submergence the controller can be asked to fail high, low or hold the last reading. When the level drops back below the shield it allows the controller to resume operation with a clean transducer face. The shield can be fitted to the dB3, dB6, dB10 and dB15 dB25 standard transducers. Note: All dB3 transducers are fitted with a shallow drip shield.



## dBMACH3 – high accuracy open channel flow transducer

Featuring unique sun and submergence shields, the dBMACH3 transducer is designed specifically for open channel flow applications. dBMACH3 is the first ultrasonic transducer with zero effective blanking distance beyond the nosecone, allowing it to be sited as little as a few mm from the high flow level. One of the critical factors affecting ultrasonic accuracy is the measurement distance and air temperature, so by minimising this distance, accuracy is maximised. Operating at 125kHz frequency the transducer provides a resulting high resolution accuracy. Essential in open channel flow applications. This dBMACH3 is used with Ultra 3 or 5 and TWIN when in open channel flow mode.

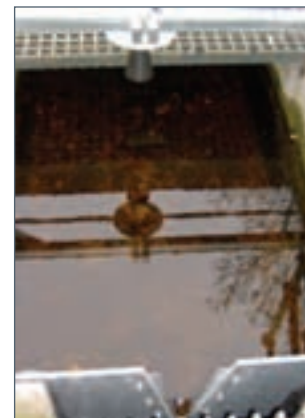

## Sanitary Flanged Transducers

For standard transducer from dB3 to dB10 an option of a sanitary flange construction exists. The flange has a full face PTFE seal for use in hygienic applications. The flange is available in 2" or 3" (on dB3) and 3" on the dB6 and dB10 units. These flanges allow Tri-Clamp fittings to be used onto tanks or vessels.





# Transducers:

## Threaded Range

dB3, dB6 and dB10 transducers are available with threaded noses for easy mounting. dB3 and dB6 models feature 1.5 inch universal thread while dB10 has a 2" universal thread. Standard transducer bodies are made from Valox 357 PBT with a special foam radiating face. All are available in optional PVDF version for corrosive applications. All performance parameters of the transducers remain unchanged.

### dB3 – solids, powders and liquids measurement to 3m

Range 0.15 - 3m, 125kHz operating frequency, <10° beam angle (-3dB inclusive).

### dB6 – solids, powders and liquids measurement to 6m

Range 0.3 - 6m, (0.2m deadband option available at 50kHz) 75kHz, <10° beam angle.

### dB10 – solids, powders and liquids measurement to 10m

Range 0.3 - 10m, 50kHz <10° beam angle.

### All

Operating temperatures -40 to +90°C (+75°C for hazardous area)

ATEX (EEx m) II T6 as standard, ATEX (EEx ia T6) I.S. intrinsically safe optional, all are IP68.

FM approved Ex-proof FM/FMC, Class I, Div. 1, Grp. A, B, C, D; Class II, Div. 1, Grp. E, F, G Optional Intrinsically Safe ATEX EEx ia IIC T6.

## Features

- Universal 1.5" or 2" BSP/NPT nose thread
- ATEX and optional FM flammable atmosphere units
- PVDF version option for corrosive applications
- I.S. approval versions available
- Rugged IP 68



ALL BEAM ANGLES ARE INCLUSIVE, BUT GIVE AN EFFECTIVE BEAM ANGLE OF <3 DEGREES ON OUR CONTROLLERS. RANGE ON POWDERS AND SOLIDS DEPENDS ON APPLICATION.

# Transducers:

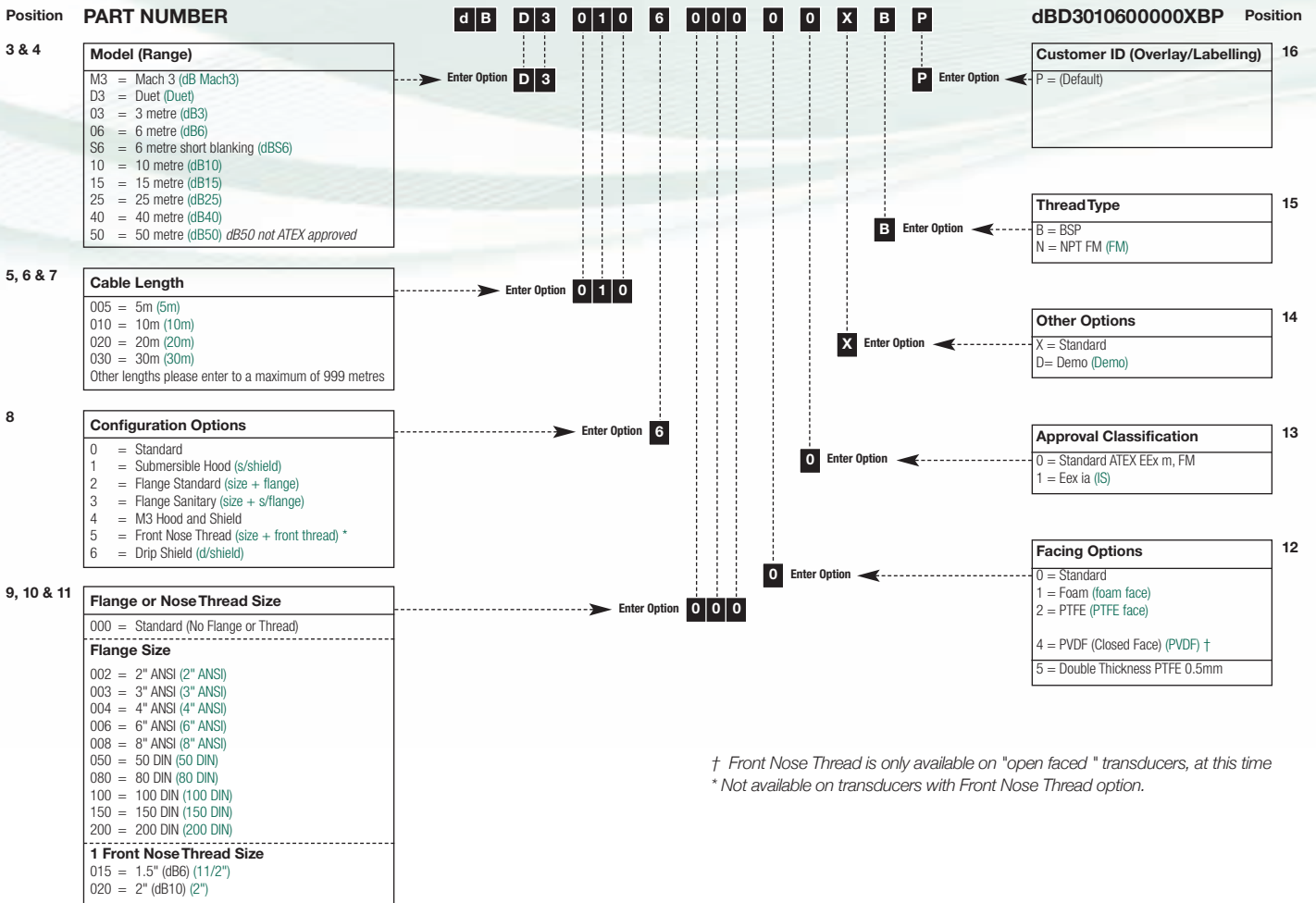

## Technical Specification: PULSAR dB Transducers

### DATA APPLICABLE TO ALL TRANSDUCERS

<b>Operating temperature range:</b>	-40°C to +90°C (Hazardous area versions +75°C max)
<b>Hazardous area approval:</b>	Standard ATEX EEx m II T6 or optional EEx ia T6 (FM approved available)
<b>Ingress protection (IP) rating:</b>	IP68 to BS EN 60068-2-17 : 1995 and BS EN 60529 (Nema 6P available)
<b>Integral cable length:</b>	Standard 5, 10, 20 or 30 metres
<b>CE Approvals:</b>	EMC tested to BS EN 50081-1 : 1992 for emissions and BS EN 50082-2 : 1995 for immunity Electrical safety tested to BS EN 61010-1 : 1993
<b>Bump, shock and vibration:</b>	To BS EN 60068-2-29, BS EN 60068-2-27 and BS EN 60068-2-6

### HOUSING DETAILS

	Housing material	Housing diameter mm	Housing height mm	Mounting connection
<b>dB3:</b>	Valox 357 *PBT	86	98	BSP or 1" NPT
<b>dB6†:</b>	Valox 357 *PBT	86	106	BSP or 1" NPT
<b>dB10†:</b>	Valox 357 *PBT	86	106	BSP or 1" NPT
<b>dB15:</b>	Valox 357 *PBT	86	120	BSP or 1" NPT
<b>dB25:</b>	Valox 357 *PBT	114	140	BSP or 1" NPT
<b>dB40:</b>	Valox 357 *PBT	205	215	BSP or 1" NPT
<b>dB50:</b>	Valox 357 *PBT	205	215	BSP or 1" NPT

### OPTIONAL FLANGES - All have PTFE full face on process side

Flanges:	ANSI	2"	3"	4"	6"	8"	DIN	50	80	100	150	200	Sanitary	2"	3"
<b>dB3:</b>		4	4	4	4	4		4	4	4	4	4		4	4
<b>dB6:</b>		4	4	4	4	4		4	4	4	4	4			4
<b>dB10:</b>		4	4	4	4	4		4	4	4	4	4			4
<b>dB15:</b>			4	4	4	4			4	4	4	4			

### OPTIONS

<b>Facings:</b>	Closed cell soft foam for increased power in dry dusty environments PTFE standard on all flanged transducers for chemical compatibility
<b>Submergence shield:</b>	For continuous operation in applications at risk of submergence
<b>Beam aiming kit:</b>	Recommended for easy transducer aiming in solids applications (drawing available on request)

dB50 not ATEX approved

† Available in optional PVDF body material (Polyvinylidene fluoride)

\*PBT - Polybutylene terephthalate

# Accessories:

Various transducer options can be provided to suit specific applications, such as submergence shields, foam faced transducers, sanitary flanges, blind flanges and a choice of transducer mounting brackets.

## Cable Options

Transducer cable lengths are supplied as a standard in 5m, 10m, 20m or 30m. Longer lengths can be supplied as required in 10m steps. It is important to note that the supplied transducer cable may be extended by using standard 2 or 3 core screened cable for up to 1000m or beyond if needed. No separation is required between transducer and other cables as it is not susceptible to cross talk and significant costs can be saved on site.

## Aiming Kit

Pulsar's robust and effective aiming kit allows the transducer to be aimed towards the material draw off point at the bottom of the silo or tank, ensuring that the returning echo is as strong as possible and that the ultrasonic system is able to measure right down to the true empty point of the silo. The location of the aiming kit should be as far away from the fill point as possible to avoid seeing falling material. It should be aimed to coincide with the material's angle of repose, ensuring a more powerful signal return to the transducer. The rotational ball mechanism allows up to 20 degrees off vertical and 360 degrees of rotation.

## Features

- Allows rotation to suit silo conditions
- Coincide with angle of repose of material being measured
- Follow material level down to draw off point
- Easy aim and lock system

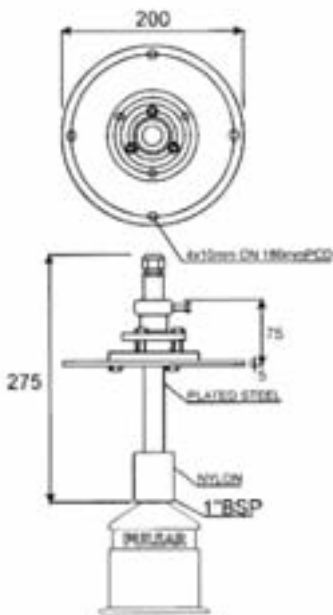

WE RECOMMEND THE INSTALLATION OF AN AIMING KIT WHEN MEASURING SOLIDS MATERIAL.



AIMING KIT ON A CRUSHER APPLICATION

## Blind Flanges

A range of blind PVC flanges with central 1" BSP or NPT hole is available. These are for mounting transducers within a standpipe or tank using rear thread or dB3 front thread mounting. These available in 2", 3", 4" and 6" ANSI or DIN 80, DIN 100, DIN 150 and DIN 200 patterns.

## Features

- Selection of DIN or ANSI patterns
- Excellent corrosion resistance



# Brackets:

## Angled Bracket



### Pulsar Fixed Angle Transducer Bracket p/n dBA004

Fixed angle bracket made from steel with a BZP (bright zinc passivate) coat. Ideal for mounting against a wall where there is an under-hang under a manhole or similar. 2 x 14mm holes allow rigid fixing into a vertical surface using suitable bolts.

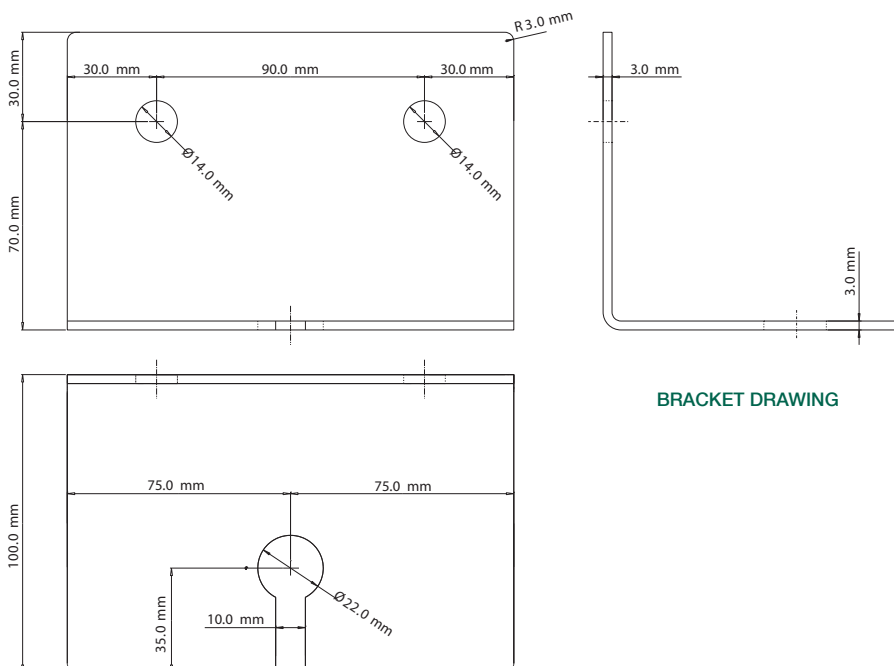

BRACKET DRAWING

# Brackets:

## Pulsar Hinged Transducer Bracket p/n dBA003

Pulsar's hinged transducer bracket is an easy-mounting solution for any of the dB series transducers, providing a stable method of positioning a transducer above an application. The bracket is made from hot dipped galvanised steel and is hinged to allow the transducer to be swivelled up for cleaning or to allow access. The transducer can then be returned to the original position with no need to recalibrate.

### Features

- Rugged construction
- Galvanised or BZP coated
- Hinge allows easy lift cleaning
- Drain holes in channel prevent liquid build up
- Simple to fit on site



The dB series transducer is mounted to one of the 22mm holes in the bracket using the 1" to 20mm adaptor provided. If one of the inner holes is used and the excess bracketry removed, the retaining thro-nut with the steel pull cable attached easily slides to a new position. The bracket is supplied with the plastic channel seal.



HINGED BRACKET OVER A WET WELL



STEEL CABLE WITH KARABINER AND NON-SLIP CONNECTORS



### BRACKET DRAWING

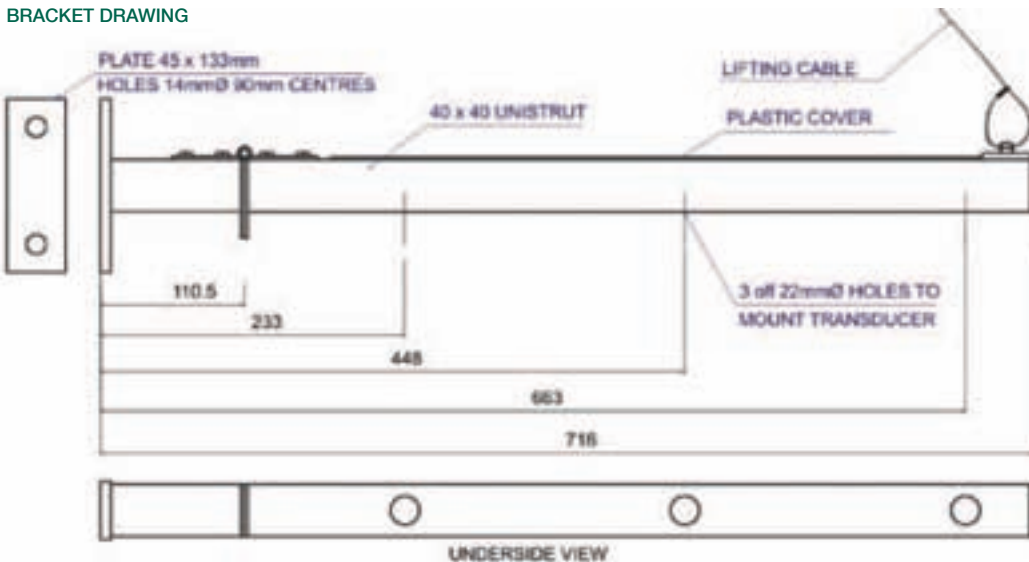

# DATEM Software:

## Ultrasonic level measurement and DATEM digital echo processing Digital Adaptive Tracking of Echo Movement

### Features

- Superb echo discrimination
- Most accurate ultrasonic level measurement system in the world
- Easy application set-up
- Locks onto the true echo, ignores interference from other signals
- Trouble free operation

As a technique, ultrasonic level measurement has been around for decades, working on the 'time of flight' principle that if you know the speed of sound, then the time that a sound pulse takes to travel from a transducer and back again may be used to calculate the distance that pulse has travelled. Divide by two and you have the distance to the 'target'.

Early analogue instruments, while they were fine for simple applications, were easily 'confused', they had to be carefully set up and the path to the target had to be clear and unobstructed, because the success of the measurement depended on the true echo returning from the target being 'louder' than any competing echo. As time went on, more sophisticated digital echo processing allowed for more discrimination of echoes, but still depended on blocking out competing echo traces and using software to identify the true echo from among the competing traces.

Pulsar pioneers the way in ultrasonic level echo processing technology. As microprocessors have improved, Pulsar has continued to develop and improve echo processing software, so that it is now

possible to make successful measurements in situations that would have been far beyond the units of even a decade ago. Pulsar's echo discrimination system, DATEM, works on the basis that it first identifies the true, moving echo from the background noise, then follows it, ignoring all of the competing echoes as it does, so DATEM allows Pulsar equipment to work in a cluttered sewage wet well, or in a noisy stone silo, an agitated tank or even through a grid. DATEM also looks for echoes within a very small frequency range, which helps to make it especially good at ignoring both acoustic and electrical noise. The high power of Pulsar's dB series transducers makes sure that all the echoes from an application can be easily monitored. The end result is highly reliable level measurement in applications which previously could not be considered.

19m STORM TANK WITH WETWELL AT BASE

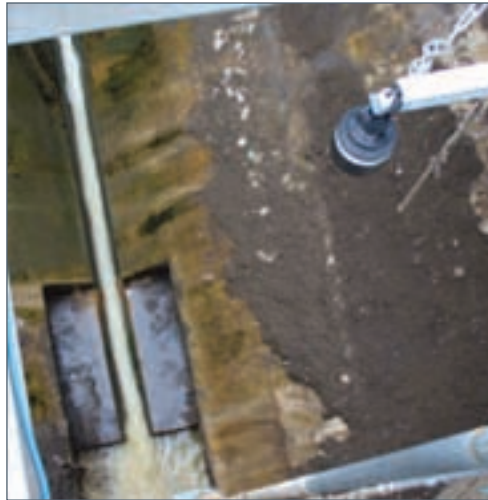

BLOCKED CHUTE DETECTION OVER 1.2m



WETWELL 6m WITH LADDER AND FLOAT



WETWELL 4.5m WITH LADDER AND FAT RING



# pulsar

## Ultra Range

### Ultra 3

page 16

Ultra sophistication in a smart package, Ultra 3 combines reliable non-contacting ultrasonic level and volume measurement, high specification pump control and open channel flow measurement to international standards. Three control or alarm relays, optional data logging, Pulsar's world-leading DATEM echo processing software and a choice of wall, fascia, panel or 19" rack mounting.

### Ultra 5

page 17

Ultra 5 continues where Ultra 3 leaves off, maintaining the same reliability, flexibility and menu-driven programming simplicity, with two extra relays, extra features for advanced pump control, differential level and open channel flow, plus the option of RS485 digital communication and 4-20 mA input.

### UltraTWIN

page 18

Two independent ultrasonic systems in one unit. Each channel is user-configurable to operate in any combination of: a full function open channel flow monitor calculating flow rate to BS ISO standards, a pump control system or as a level and volume monitoring unit for liquids or solids, calculating volumes and providing alarms. UltraTWIN features six relays configurable for either channel as well as four digital inputs and 2 x 4-20mA outputs.

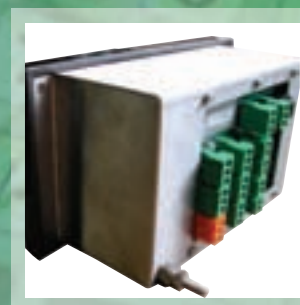

# Ultra Range:

## Ultra 3

### Features

- Solids or liquids level measurement
- Choice of wall, panel, fascia or 19" rack mount controllers
- RS232 standard with optional 485 Modbus and Profibus
- AC or DC supply as standard
- No special interconnection cable
- Up to 1000m separation
- Ultra Wizard easy set up
- Backlit display
- DATEM Software



PANEL MOUNT OPTION



19" RACK MOUNT OPTION

Ultra 3 combines several full-function, world-beating ultrasonic level measurement instruments into one. Pulsar engineers have created devices that can be simply configured by the user to provide top-drawer performance. Through the use of ULTRA WIZARD, an integrated high level software configuration tool, you choose your application and the Ultra unit leads you through the set-up process for that specific operation. Full control functions are available: open channel flow is calculated to BS ISO 1438 and 4359. Pump control features are built into Ultra 3, and an extensive set of volume calculations and linearisation facilities are available for a tank or silo level measurement task.

Ultra 3 features the benefits of DATEM, the world's most advanced echo processing software, for level measurement.

### Level

Perfect for the wide range of level measurement applications in solids and liquids found in the food, pharmaceutical, chemical, power generation and many more industries. In level measurement configuration, Ultra 3 has three control relays and a measurement range from 125mm to 40m.

### Volume

Ultra 3 features pre-programmed tank shape conversion for a wide variety of standard tank shapes including: cylindrical, rectangular, cone base, pyramid base, sloped base, horizontal including parabolic ended tanks and spherical. Unusual shapes are also accommodated through the 32 point linearisation function.

### Display:

- 8 digit on-board totaliser
- 6 digit display of flowrate or head
- Bar indicator displaying head or flow

### Pump control

Pulsar pump control units are used throughout the global water and waste industries. Ultra 3 gives you sophisticated pump control on changing level or rate of level change to provide:

- **Power on delay**, allows to delay switching on pumps when power resumes.
- **Pump start delay**, allows delay switching on pumps after another has started.
- **Fixed duty assist**
- **Fixed duty back up**
- **Alternate duty assist**
- **Alternate duty back up**
- **Duty back up and assist**
- **Service ratio duty assist**
- **Service ratio duty back up**
- **FOFO (alternate first on first off duty assist)**

### Open Channel Flow

Ultra 3 in open channel flow mode provides non-contacting, maintenance free flow measurement and control in a wide range of flumes and weirs by calculating flow from the measured head preceding a primary element. Flow calculation to BS ISO 1438 and 4359. Three control relays for control choices.

A data logging board is an optional extra with RS485 connection and large data log capability together with Profibus DP V0 and V1 or Modbus communications.



WALL MOUNT ULTRA 3 and 5



# Ultra Range:

## Ultra 5

Ultra 5 offers the ultimate flexibility in ultrasonic control and measurement. Like Ultra 3, Ultra 5 is user-configurable to measure level or volume, provide advanced pump control or measure open channel flow to BS ISO 1438 and 4359. Over and above the facilities offered by Ultra 3, Ultra 5 gives you the ultimate flexibility of: five assignable relays with extra alarm options such as pump efficiency; extra pump control functions including pump run-on and pump exercising; storm and aeration control; differential control using two transducers, the addition of further relays in OCM applications.

Ultra 5 features the benefit of DATEM, the world's most advanced echo processing software, for reliable level measurement.

### Level

All the features of the Ultra 3 with 2 additional relays. Offers optional 4 - 20mA input for a pressure transmitter or similar.

### Volume

All the features of the Ultra 3 with 2 additional control/alarm relays.

### Pump control

Ultra 5 in pump control configuration is a premium specification ultrasonic pump control unit offering many standard features. Advanced control functions include:

- **Pump run-on**, allowing the user to set both the run-on interval and the duration, for periodic pumping past the off point to remove solids from pump stations.
- **Pump exercising**, causes pumps to come on when a period of non operation has occurred, idle time and exercise time can be set.
- **Start point variation**, reduces material build up on the walls at the 'normal' level by setting a band in which the switch point varies.
- **Storm control feature** permits the identification of a storm condition and operate any relay with specific points being set to accommodate needs during a storm, and the ability to disable other relays during the storm if required.
- **Aeration control** activates on elapsed time (since pumps ran), in little used well. Introduces air to reduce well gases.
- **Flush valve control** activates a re-circulation valve for a specific time based on pump cycle frequency, Prevents solids settling.

### Data logs

- Running total of individual pump running hours.
- Running total of individual pump starts
- Running total of individual pump run-ons.

### Differential

Ultra 5 offers further sophistication with the inclusion of differential level capability using two transducers. With one upstream and the other downstream of a screen or penstock, an alarm or control signal is initiated as the difference between the level exceeds a user-defined limit to automatically operate the cleaning mechanism.

### Open Channel Flow

All the features of the Ultra 3 with 2 additional relays. With the additional step/time control for use with a penstock.

A data logging board is an optional extra with RS485 connection and large data log capability together with Profibus DP V0 and V1 or Modbus communications.

## Features

- Solids or liquids level measurement
- Linearisation for tank shapes
- Advanced pump control choices
- Pump efficiency alarm
- Optional 4 - 20mA input
- Wide choice of flumes and weirs in OCM
- Easy prompt set up
- DATEM software



FASCIA MOUNT OPTION



FASCIA MOUNT REAR VIEW

# UltraTWIN:

## Features

- 2 independent channels
- Wall or Fascia mount options
- Datalogging option
- Easy prompt led set up

Twin-channel ultrasonic level/volume monitoring, pump control, open channel flow measurement or any combination of these.

Flexibility is the keyword for the UltraTWIN 2 channel ultrasonic system. Each channel is user-configurable to operate independently either as a full function open channel flow monitor calculating flow rate to BS ISO 1438 and 4359, a pump control system or as a level and volume monitoring unit for liquids or solids, calculating volumes and providing alarms. UltraTWIN is compatible with the full range of Pulsar's dB transducers, from the ultra-high resolution dBMACH 3 to the powerful 40m range dB40. Six relays configurable to either channel provide full alarm and control options.

## Level/Volume measurement

Use the level/volume measurement setting and ultraTWIN provides everything you would get from the Pulsar Ultra 3 or Ultra 5 in level measurement mode. UltraTWIN in level/volume mode will calculate volumes based on a wide variety of standard tank shapes and is equally at home measuring liquids and solids.

## Open Channel Flow measurement

When you select the Open Channel Flow option, you are getting the full power of Pulsar's flow measurement expertise, the choice of waste water companies and process industries worldwide to measure open channel flow within effluent treatment processes. Features include on-board totalisation and pulsed output. UltraTWIN provides outstanding accuracy when teamed with the high resolution accuracy of the dBMACH 3 transducer.

## Pump Control

In pump control configuration, ultraTWIN provides all the power of the Pulsar Ultra 3. Extremely reliable level monitoring even in the most difficult applications, it also provides a wide range of sophisticated pump control routines to keep the application running perfectly. UltraTWIN also includes four digital inputs, making it possible to monitor the performance of other equipment, for example a no-flow signal from a pump can trigger an alarm without the need for a PLC.

## Data logging/Digital Communications

A powerful data logging solution can be added to the ultraTWIN system. As a factory fit option, level and flow information is recorded and "date stamped" at user defined intervals to build up a complete picture of the changing situation on site. Information may be stored for up to a year, and easily downloaded to a computer through a standard RJ11 port. The data logging solution offers Pulsar's PC Ultra Log software package, which records and charts data and trends in an easily accessible form.

UltraTWIN may also be upgraded to include RS485 communications, operating the Modbus or Profibus DP V0 or V1 protocols.



# Ultra Wizard:

A high level software configuration tool allowing the user to dedicate the device to a specific function.

**Ultra Wizard is an on-board, menu-driven software tool that allows the user to quickly and simply set up an Ultra 3, 5 or ultraTWIN unit for a specific application.**

Simply enter the programming code (1997) and Ultra Wizard leads the user through a set-up menu. From the first question, do you want me to operate as:

1. Level/volume controller, or
2. Pump controller, or
3. Open Channel Flow.

The user is led into a 'Quick Setup' menu specific to the application type that allows parameters such as empty and full distances and alarm/control relay settings to be entered. The majority of applications will then be 'ready to go', while it is easy to finish off the more demanding installations via further menus, refining the programming to add extra sophistication such as Ultra 5's advanced pump control routines.

The unique 'Quick Setup' allows a user to avoid time-consuming programming and reference to parameter numbers.

## Features

- Absolute flexibility
- User choice of function
- Lowers controller stockholding
- Simple to set up
- Units can be reprogrammed to suit changing applications



# Product comparison:



	Functions													
	Ultra 3				Ultra 5				Ultra TWIN					
	level	volume	pump control	open channel	level	volume	pump control	differential	open channel	level	volume	pump control	differential	open channel
Three control/alarm relays	•	•	•	•										
Five control/alarm relays					•	•	•	•	•					
Six control/alarm relays									•	•	•	•	•	•
Compatible with all dB family transducers for 125mm to 40m measurement range (X=db15max)	X	X	X	X	•	•	•	•	X	•	•	•	•	X
High accuracy dBMACH3 transducer	•	•	•	•	•	•	•	•	•	•	•	•	•	•
Liquids, solids and dusty applications	•	•	•	•	•	•	•	•	•	•	•	•	•	•
I.S. transducer (EEx ia) option	•	•	•	•	•	•	•	•	•	•	•	•	•	•
Wall, fascia, panel and 19" rack mount versions (wall and fascia only on ultraTWIN)	•	•	•	•	•	•	•	•	•					
<b>Volumetric conversion (12 tank shapes)</b>		•				•				•				
<b>Alarm Functions on changing level to provide:</b>														
High/Low level	•	•	•	•	•	•	•	•	•	•	•	•	•	•
In band/out of band	•	•	•	•	•	•	•	•	•	•	•	•	•	•
Rate of fill and empty	•	•	•	•	•	•	•	•	•	•	•	•	•	•
High/Low temperature	•	•	•	•	•	•	•	•	•	•	•	•	•	•
System fail (loss of echo)	•	•	•	•	•	•	•	•	•	•	•	•	•	•
Pump efficiency							•							
Fill/empty control (initiate/stop)	•	•			•	•	•		•	•		•		
Differential control/alarm using two transducers								•					•	
<b>Pump control functions:</b>														
Fixed duty assist			•	•			•	•			•	•	•	
Fixed duty backup			•	•			•	•			•	•	•	
Alternate duty assist			•	•			•	•			•	•	•	
Alternate duty backup			•	•			•	•			•	•	•	
Duty backup and assist			•	•			•	•			•	•	•	
Service ratio duty assist			•	•			•	•			•	•	•	
Service ratio duty backup			•	•			•	•			•	•	•	
FOFO (first on first off alternate duty assist)			•	•			•	•			•	•	•	
Standby			•	•			•	•			•	•	•	
Pump by time feature							•					•		
2 pump sets (4 pumps total)							•					•		
<b>Advanced pump control functions:</b>														
Pump run-on							•					•		
Power on/off delay							•					•		
Pump start/stop delay							•					•		
Pump exercising							•					•		
Pump start variation							•					•		
Storm control feature							•					•		
Aeration control							•					•		
Flush valve control							•					•		
<b>Data logs:</b>														
Pump running, run-on hours							•					•		
Number of pump starts							•					•		
Maximum and minimum recorded temperatures	•	•	•	•	•	•	•	•	•	•	•	•	•	•
Optional datalogging board for expanded logging capacity and Modbus or Profibus connectivity	•	•	•	•	•	•	•	•	•	•	•	•	•	•
Differential (using two transducers)								•					•	

## Functions

	Ultra 3				Ultra 5				Ultra TWIN					
	level	volume	pump control	open channel	level	volume	pump control	differential	open channel	level	volume	pump control	differential	open channel
<b>Open channel flow</b>				•					•					•
Simple exponential (venturi, parshall, trapezoidal weir etc)				•					•					•
Selected primary element to BS3680, ISO1438 and 4359				•					•					•
Flumes: rectangular, u-throated				•					•					•
Thin plate weirs (standard V-notch)				•					•					•
Thin plate weirs: Rectangular and V-notch 90° and 60°				•					•					•
Other types (Palmer-Bowlus, H-flume etc)				•					•					•
Universal flow calculation (32 setpoints)				•					•					•
Penstock control using step time				•			•	•					•	•

### WALL MOUNT

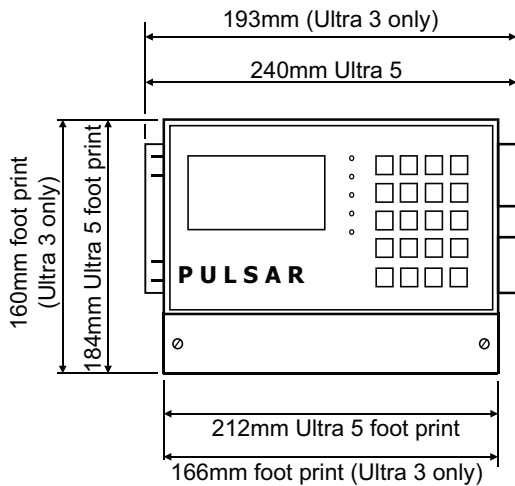

Unit Depth - 108mm

### FASCIA MOUNT

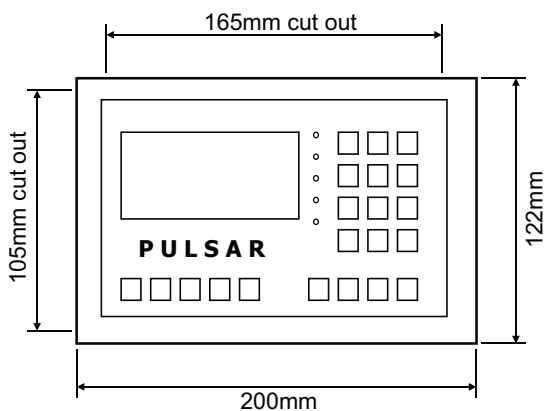

Unit Depth - 108mm



RAIL TRUCK LEVEL FOR WATER SPRAY CONTROL

### 19" RACK MOUNT

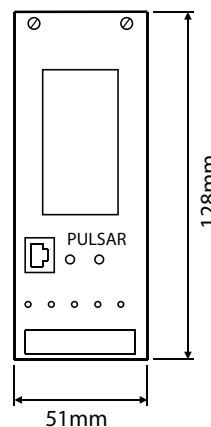

### PANEL MOUNT

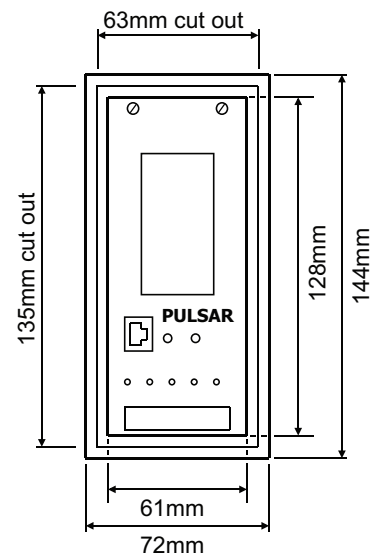

Unit Depth - 176mm

# Ultra PC Software:

## Features

- Allows 'cloning of units'
- Real time recording of echo trace
- Stores all calibrated parameters by site
- Clean effective and accurate storage
- CD with USB port or serial connection leads
- Easy to operate and setup

Ultra PC software is a powerful tool that fine tunes the Ultra series of controllers, helping the user get the best from their level or flow system.

Ultra PC can be used to record all the parameters for your applications, these may be saved to PC, disc or email. All programming parameters can be changed and downloaded to the instrument via your laptop or PC. The software may also be used to record echo profiles of your applications, these can be saved for

your records or sent via e mail back to Pulsar for analysis. PC Ultra can also record echo profiles, allowing them to be saved for your records or emailed to Pulsar for analysis. Events may be recorded and logged over long periods of time, creating an archive of level or flow variations.

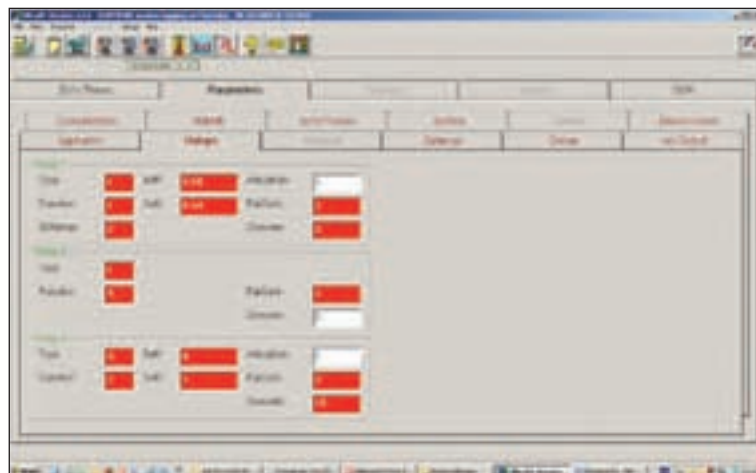
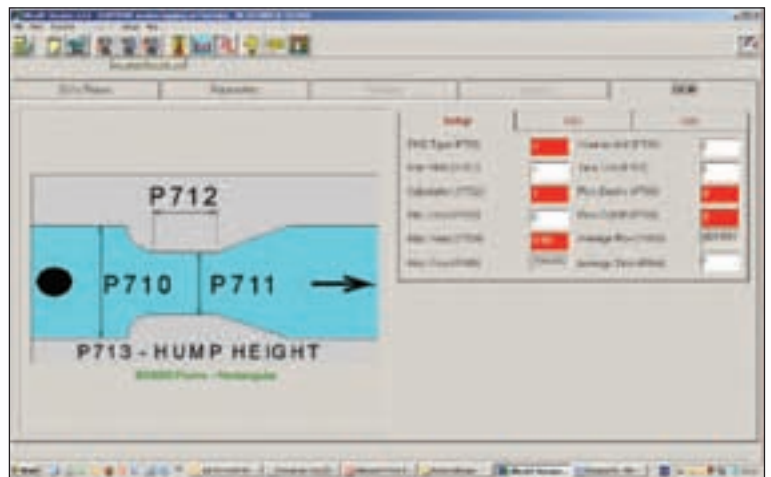
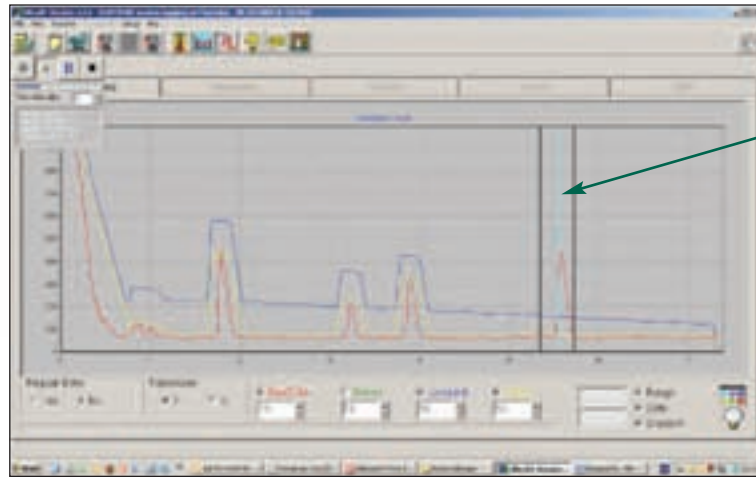

# Pump Control:



7m PUMP CONTROL



27m STORM TANK 3 PUMPS  
DOWN CENTRAL WELL



4m TIGHT WELL



3.5m FOAMY WETWELL PUMP CONTROL



4m WETWELL PUMP CONTROL AND HIGH FILL RATE

# Differential Level:



5m CANAL DIFFERENTIAL



9m HARBOUR DIFFERENTIAL



1.5m SCREEN DIFFERENTIAL

# Open Channel Flow:



RECTANGULAR WEIR FLOW



AREA X VELOCITY IN A CHANNEL USING SPEEDY and dBS6



RECTANGULAR FLUME FLOW



RECTANGULAR WEIR and DUET TRANSDUCER



RECTANGULAR FLUME and dBMACH3



FLOW BOX WITH A V-NOTCH WEIR and dBMACH3

# Volume Measurement:



CEMENT 12m



FUEL OIL 9m



LIME SILOS 9m



CLINKER 14m



CHEMICAL TANK WITH STANDPIPE 1.9m



PLASTIC PELLET SILOS 18m



# pulsar

## Specialist Ultrasonic Range

### FlowCERT/DUET/Speedy page 26-28

Pulsar's FlowCERT is a complete solution for high-accuracy measurement of open channel flows. Teamed with the temperature independent DUET transducer array, FlowCERT achieves the highest possible accuracy in flumes and weirs, and includes 5 alarm or control relays and data logging facilities. For applications where no PMD exists, FlowCERT works with Pulsar's Speedy velocity sensor.

### Zenith page 31-33

Zenith is a full function pump station controller with six control relays and a host of sophisticated features including Tariff Guard, which saves energy costs by minimising pumping during high tariff periods, and seven digital inputs. A uniquely intelligent performance.

### Quantum page 34-36

Quantum – the last word in intelligent pump station control.

Featuring ten digital outputs and seven digital inputs, together with Pulsar's Tariff Guard software and digital communications, Quantum will provide alarms, including a unique alarm warning of 'time to spill' particularly in critical areas, minimise pump usage in periods of high energy costs (TRIAD periods - pat pending) and reset tripped pumps automatically, so staff may never have to visit site just to reset a pump.

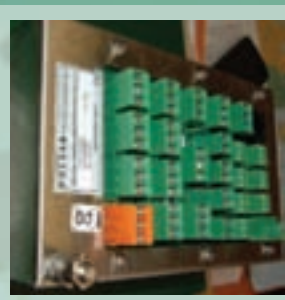
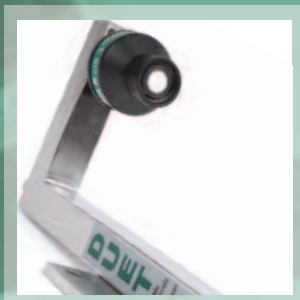

# FlowCERT:

High accuracy flow on weirs, flumes and area x velocity

## Features

- Most accurate OCM in the world (MCERTs class 1)
- Can be used for Area x Velocity
- Easy prompt set up
- Large standard on board memory gives 1 year log at 10 min intervals
- Modbus and

Pulsar's FlowCERT system gives you everything you need for the industry's highest accuracy non-contacting ultrasonic measurement of open channel flows. Designed for flumes and weirs, FlowCERT gives temperature-independent, reliable measurement and logging facilities. It includes five alarm/control relays plus 4-20mA output, datalogging, digital input with the ability to accept a velocity sensor input for non PMD applications. Programming the unit is a simple, menu-driven process. MCERTs class 1 approval when used with DUET.

- **Five control/alarm relays**

- Choice of transducers
- I.S. transducer (EEx ia) option
- Wall mounted

- **Alarm functions**

- High/Low level
- In band/out of band
- Rate of level rise/fall
- High/Low temperature
- Loss of Echo

- **Data logs**

- (all date/time stamped)
- Flow rate (variable time intervals)
- Total flow (and daily totals etc)
- Average flow rate
- Temperature (max/min)
- Echo confidence and more...

- **Flow totalisation and outputs**

- Relay closure assignable to totalised flow for remote totaliser
- Relay closure assignable for flow volume or time for a flow sampler
- Ten days logged flow at 24 hour intervals recorded by date and accessible via the key pad.

- **Open channel flow elements**

- Simple exponential (venturi, parshall, trapezoidal weir etc)

- **Selected primary** element to BS 3680,

- ISO 1438:2008 & 4359:1983 etc.

- Flumes: rectangular, u-throated
- Thin-plate weirs (standard v-notch)
- Thin-plate weirs (rectangular and v-notch 90° and 60°)
- Other international standards (Palmer-Bowlus, H-flume etc)

- **Universal flow calculation (32 setpoints)**

- **Penstock control using step time**

- **Option: Speedy velocity sensor for area x velocity (Q=VA calculation) in channels or pipes**



Sira MC 090154/00

# DUET: patent pending

## Dual Ultrasonic Echo Transducer

FlowCERT and Pulsar's unique twin-transducer DUET, provides the highest accuracy non-contact ultrasonic flow measurement system available.

The speed of sound varies with air density change; as the temperature varies, so does the time it takes for an echo to reflect from the target, and therefore the accuracy of the measurement is significantly affected. Temperature compensation of various types may help, but are heavily dependent upon good siting and are slow to respond. The air temperature gradient between the liquid surface and the air is often large and temperature sensors are not representative of the variation in air density. Only DUET features Pulsar's unique, patented, approach to the issue. Both transducers fire together. By continuously monitoring the phase difference of the echoes, and because the distance between the transducer faces is known and constant, the speed of sound is continuously updated in real time on the process. The resulting accuracy and stability is exceptional.

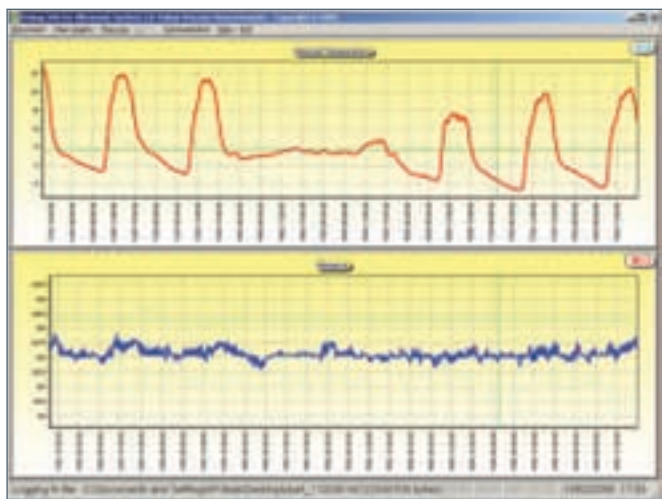

THIS CHART SHOWS HOW A MEASUREMENT OF DISTANCE VARIES (LOWER TRACE) AGAINST CHANGES IN TEMPERATURE OVER THE PERIOD OF A WEEK. DESPITE TEMPERATURES RANGING FROM OVER 25°C DOWN TO -7°C, THE MEASUREMENT REMAINED EXTREMELY CONSTANT, WITHIN  $\pm 0.5\text{MM}$ , ON A RANGE OF 383.5MM.



Sira MC 090154/00

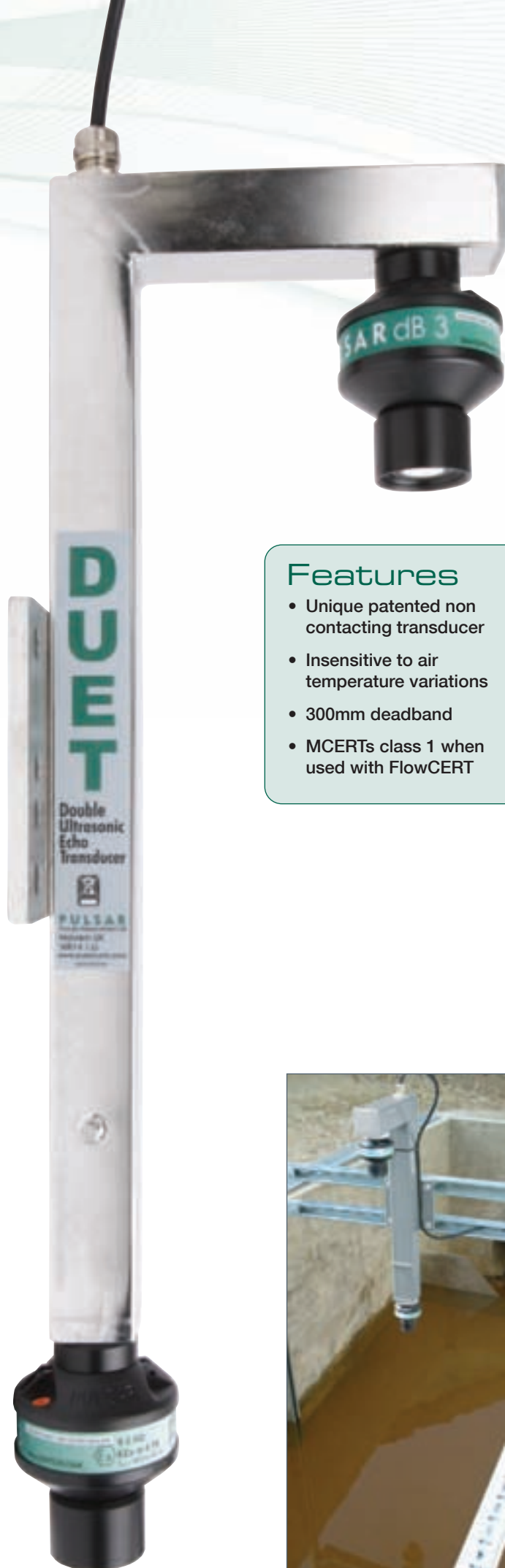

### Features

- Unique patented non contacting transducer
- Insensitive to air temperature variations
- 300mm deadband
- MCERTs class 1 when used with FlowCERT

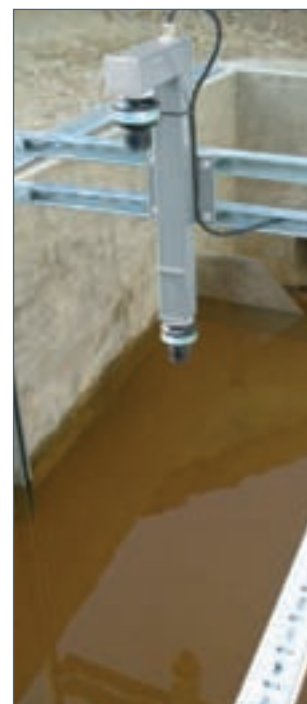

# Speedy:

## Liquid velocity sensor

### Features

- streamlined, easy to fit sensor
- In channels, pipes where no PMD is fitted
- Wedge base mount or pipe mount option
- Reliable proven and easy set up

The latest version of Pulsar's popular "Speedy" velocity sensor, for use in channels, pipes or sections where no Primary Measurement Device (PMD) exists. New Speedy performs all its calculations internally, removing the need for a separate converter unit.

WEDGE SENSOR



Communication with the FlowCERT unit is via RS485, and Speedy can be mounted up to 300m from the FlowCERT controller. Speedy is available as a "wedge" sensor with a stainless steel base plate or as a pipe mounted sensor (pictured below).

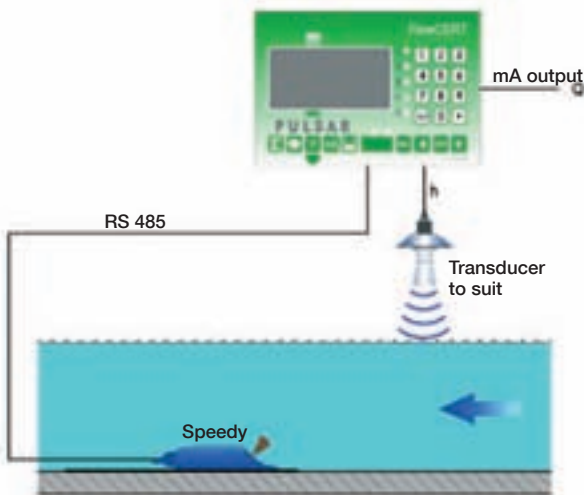

### U-THROATED RECTANGULAR OR TRAPEZOIDAL CHANNELS

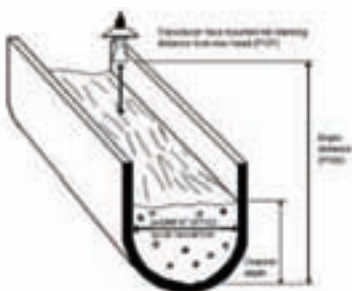

### CIRCULAR PIPES

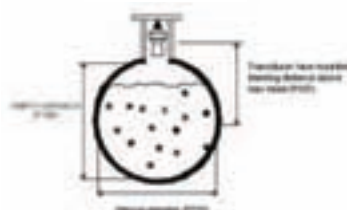

PIPE INSERTION SENSOR

# Speedy Interface:

## Digital to analogue converter

**Pulsar's Speedy Interface is a digital to analogue converter that works with the latest Speedy velocity sensor in two important ways. It frees up the RS485 output from a FlowCERT controller in applications where digital communications are required, and allows users of Pulsar's older equipment to upgrade to the latest Speedy sensor. It also provides the option of alarms based on flow velocity.**

Pulsar's Speedy velocity sensor communicates digitally and is designed to connect to Pulsar's FlowCERT open channel flow monitor via FlowCERT's on-board RS485 interface board, where it provides the velocity measurement for velocity x head calculations of flow volume where no primary measurement device exists. However, there are some applications where external digital communications are required, for example to network flow measurements or to modify the programming of the unit. Speedy Interface converts the digital output of the Speedy doppler velocity sensor into a 4-20mA signal proportional to flow velocity, which can then be

fed into the analogue input terminal on the FlowCERT controller. This then leaves the RS485 connection included in the FlowCERT unit free to be used for digital bus communications.

Speedy interface is easily configured using the integral keyboard, and includes a display of flow velocity. There are two on-board relays that can provide alarms or control signals on high or low flow velocity. The Speedy Interface is self-contained to the extent that it can be used without the FlowCERT controller where a simple alarm on flow velocity or a 4-20mA signal proportional to velocity is required.

### Features

- Allows Modbus or Profibus comms when using Speedy sensor
- Gives backwards compatibility to previous Speedy units



## Technical Specification: FlowCERT/DUET/Speedy

FLOWCERT CONTROLLER	
<b>Volt free contacts:</b>	5 form C (SPDT) 5A, 240V ac
<b>Outside dimensions:</b>	240 x 184 x 118mm
<b>Cable entry:</b>	10 cable entries - 5 x M20, 1 x M16 underside, 4 x 18mm at rear
<b>Weight:</b>	Nominal 1kg
<b>Case material:</b>	Polycarbonate, flame resistant to UL94-V2
<b>IP rating:</b>	IP65
<b>Max and min temp. (electronics):</b>	-20°C to +50°C
<b>Flammable atmosphere approval:</b>	Safe area: compatible with approved dB transducers (see transducer specification sheet)
<b>CE Approval:</b>	EMC approval to BS EN 50081-1:1992 for emissions and BS EN 50082-2:1995 for immunity, and to BS EN 61010-1:1993 for low voltage directive.
<b>Echo processing:</b>	Patented DATEM (Digital Adaptive Tracking of Echo Movement)
<b>Analogue output x2:</b>	Isolated output 4-20mA or 0-20mA into 500Ω (user programmable), 0.1% resolution
<b>Serial output:</b>	Full duplex RS232 via RJ11 port
<b>Digital output:</b>	RS485 conn for Modbus with Profibus DP V0 or V1 options
<b>Display:</b>	6 digits plus 12 character text, plus bargraph with direction indicators, remote communicator identifier and program/run/test mode indicators
<b>Data logging:</b>	Via RJ11 port has 256kb giving 1 year at 10 min intervals (needs ultralog PC software)
<b>Programming:</b>	Integral keypad. Also PC Programming via RS232 (RJ11 port) or RS485
<b>Programming security:</b>	Via password (user selectable and adjustable)
<b>Programmed data integrity:</b>	Via non-volatile RAM, plus backup
<b>Power supply:</b>	115V ac +5% -10% 50/60Hz, 230V ac +5% -10%, 18-36V dc
DUET	
<b>Mode of operation:</b>	Twin transducers, fixed distance apart, firing together
<b>Transducer types:</b>	2 x Pulsar dBMACH3, 125KHz frequency, beam angle 10° (@ -3dB)
<b>Range:</b>	300mm - 2m (from face of lower transducer)
<b>Hazardous area:</b>	ATEX EEx m IIT6 for Zone 1 and 2. FM available
<b>Transducer cable:</b>	Three core screened, can be extended with 2 or 3 core screened
<b>Maximum separation:</b>	500m from transducer to control unit
SPEEDY VELOCITY SENSOR	
<b>Measurement principle:</b>	Doppler (flow velocity). Flow velocity sensor with v measurement using Doppler principle and temperature measurement to compensate temperature effects on speed of sound.
<b>Measurement frequency:</b>	1MHz
<b>Protection:</b>	IP68
<b>Operating temperature:</b>	-20°C - +50°C
<b>Storage temperature:</b>	-30°C - +70°C
<b>Operating pressure:</b>	max 4bar
<b>Cable length:</b>	10/15/20/30/50/100 metres pre-cut, extendable to max 250m
<b>Cable types:</b>	LiC11Y 2x1.5 + 1x2x0.34
<b>Cable diameter:</b>	8.4mm ± 0.25mm
<b>Constructions:</b>	Wedge sensor for installation on channel bottom Pipe sensor for installation using nozzle and cutting ring screw joint in pipes
<b>Contacting materials:</b>	Wedge sensor: Polyurethane, stainless steel 1.4571, PVDF, PA Pipe sensor: stainless steel 1.4571, Polyurethane, FEP coated cable
<b>Measurement range:</b>	-6m/s - +6m/s
<b>Zero point drift:</b>	0 - absolutely stable zero point
<b>Sonic lobe:</b>	±5 degrees
<b>Temp. measurement:</b>	-20°C - +60°C ±0.5°C

# Zenith:

## Intelligent Pump Controller

The Pulsar Zenith Intelligent Pump Controller is a high specification pumping station management system, offering unrivalled performance. Using Pulsar's proven non-contacting ultrasonic technology it provides almost all known pumping routines in an easy to use package. By combining advanced ultrasonic level measurement with the control and monitoring of pumps and providing many other control functions, it is possible to eliminate a PLC by using Zenith in a smaller station.

Significant capital and operation cost savings can be achieved by using advanced truly unique patented peak tariff avoidance (Tariff Guard) control software to enable efficient control of pumps to optimise the use of minimum cost electricity in a station or well.

The Zenith system, incorporates back lit LCD display, ac and dc supply capability in optimising one unit, advanced pump control software routines, digital (RS232) and RS485 Modbus and Profibus communication options. It is available in an IP 64 fascia mount configuration to suit MCC and panel fronts.

### Tariff Guard

- Provides significant energy saving by maximising pump use during low rate electricity cost periods, and limits pump use during high cost tariff periods. There are 10 user definable periods, which may be set at any time during the week, or set to a recurring program.

### Daylight

- When selected, automatically corrects for the relevant months of daylight saving time.

### Digital Inputs

- 7 digital inputs allow multi purpose alarm and control sequences for pump failure, other external inputs such as a rain gauge, or control inter locks may be used to monitor a control event, manual override or reset, switches inhibit or enable.

### Pump Control Features

**Advanced pump control on changing level to provide:**

- Fixed duty assist
- Fixed duty back up
- Alternate duty assist
- Alternate duty back up
- Duty back up and assist
- Service ratio duty assist
- Service ratio duty back up
- Two pump set
- FOFO (first on first off) duty assist
- Duty Standby

### Alarm Functions

**Alarm Functions to provide:**

- High or low level
- In or out of band
- Rate of filling or emptying
- High or low temperature
- System failed
- Pump efficiency

### Data Logs

- Running total of individual pumped volume
- Running total of individual pump running hours
- Running total of individual pump starts
- Running total of individual pump run-ons
- Individual pump efficiency

### Volumetric Throughput

- Conversion of level measurement into pumped volume throughput, stored in an 8 digit memory, with the ability to monitor a variety of well shapes and provide custom linearisation of non-standard shapes.

Specifying information and wiring diagrams are available on request from Pulsar

## Features

- Advanced Pump control features as standard
- Reduce capital costs by eliminating PLC on small sites
- Reduce panel depth and size
- Reduce power costs by intelligent use of lower tariff periods for pumping
- Monitoring of pumps or controls via the 7 digital inputs
- Easy prompt led menu system with clear back lit display
- RS232 with RS485 Modbus or Profibus DP V0/V1 options
- Totalised volume throughput of well or station
- Small panel footprint and only 90mm inside projection



# Zenith:

## Intelligent Pump Controller

### Power Cost Saving Feature (Tariff Guard)

Zenith operates in a highly intelligent and predictive manner, the concept is to have a 'full' or 'empty' well at the tariff change period.

The liquid level and the inflow rate is continually measured and assessed in the well. Both these variables are then related to the time the next tariff charge occurs. If the next tariff change is for a higher cost rate, the well will be first filled to enable pump down immediately prior to the tariff change, this then provides maximum storage capacity in the well during the higher tariff period, once in the lower tariff cost period the level is pumped down as normal using the minimum number of pumps.

Zenith continually monitors the level and inflow condition of the well to optimise the liquid level and intelligently control the pumps according to the impending tariff change. By doing this, high tariff charge pumping may be reduced significantly, or avoided entirely, to provide real cost savings on pump energy charges, especially during higher energy cost periods.

Ten set points for tariff variations may be installed, these can be assigned per day, week, or other re-occurring periods to be site specific.

It is important to note that the normal pump on and off points are maintained, and that storm capacity is normally available.

Actual energy savings achieved will depend on the capacity of the wet-well, the frequency of the tariff changes, the size of the pumps and the relative tariff charges applied. However cost savings are usually significant.

These features may also be utilised for sites where noise at night or other environmental pressures require minimal pump activity which can be set by time of day/night.

### Simple Calibration

The Zenith is calibrated via the unique simple menu driven system, or if there are a number of typical pumping stations the unit may be assigned a factory set up routine to enable the operator to simple select 3 menu options as follows:

- The pumping routine that is required
- Transducer type being used
- The working span required

This saves time on site but also reduces the potential for any errors during the set up process. This also removes the necessity for other control devices or for complicated setup routines.

### Digital Inputs

The Zenith Intelligent Pump Controller gives the operator the ability to replace costly PLC control systems on simple pumping stations. By utilising the ultrasonic level measurement units abilities, duplication of functionality may be avoided. Having 7 discreet digital inputs, the Zenith has the ability to detect a no flow signal from a switch or other source, and then create an alarm output as well as taking the defective pump out of service whilst changing the duty of the pumps as a result. Pumps may be placed on over-ride or inhibit at any time via a digital input. Communication and resulting control is via outputs including 6-volt free contacts, an isolated 4-20mA signal and RS485.

The Zenith removes the necessity for other control devices by carrying out full control of a wet-well and providing the diagnostic feedback to enable confident management of a site.

Manual switches may be linked to Zenith via the digital inputs enabling choices of pump overrides, to reset alarms or pumps back into service.

### Volume Throughput

Conversion of the level measurement into stored volume throughput, with the ability to accommodate a variety of well shapes and to custom linearise for non standard wells is included. This feature is useful for monitoring local flow changes and for well capacity performance when part of an integrated flow system.

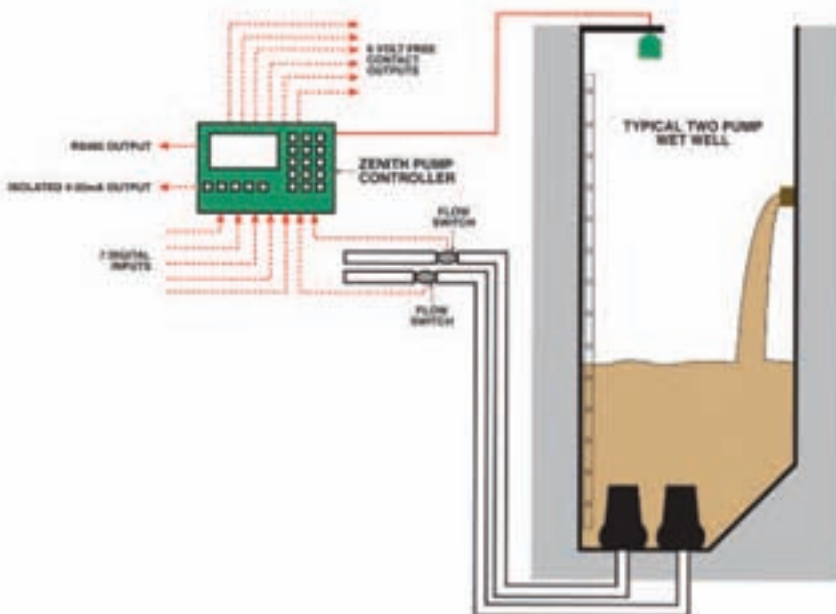



### Convenient Installation

The fascia mounted Zenith is a convenient size for panel front mounting. Having only a 15mm external projection and a 90mm internal projection this package allows reduced panel or MCC sizes. A rectangular cut-out with 4 holes to suit the rear fastening is convenient and easy to produce.

The rear of the Zenith has a stainless steel enclosure with clip on electrical connections giving safe and easy access to the power and control terminals to suit the specific site. The integral keypad on the IP64 front panel makes set-up easy and the back-lit display provides useful information during calibration and run mode.

The rear connectors include RS232 port local uploading and downloading of stored information via Pulsar Ultra PC software, and an RS485 connection for optional communication purposes.

## Technical Specification: PULSAR Zenith

PHYSICAL	
Outside dimensions (fascia) / Weight:	200 x 112 x 108mm / Nominal 1kg
Case material/description:	Stainless steel and polycarbonate, flame resistant to UL94-V0
Transducer cable requirements / Maximum separation:	Standard twin screened / 1000m
Cable connection details:	Push on screwed identified terminals
OPTIONS	
Digital comms (optional):	RS485 - Modbus RTU / ASCII, Profibus DP V0 or V1 (communications)
ENVIRONMENTAL	
IP fascia mount:	IP64
Max. and min. temperature (electronics):	-20°C to +50°C
Flammable atmosphere use:	The Pulsar Ultra is used in conjunction with the dB series of transducers which are available for use in a hazardous area (see transducer specification sheet)
CE approval:	EMC approval to BS EN 50081-1:1992 for emissions and BS EN50082-2:1995 for immunity, and to BS EN61010-1:1993 for low voltage directive
PERFORMANCE	
Accuracy:	0.25% of the measured range or 6mm (whichever is greater)
Resolution:	0.1% of the measured range or 2mm (whichever is greater)
Max. range:	3 m (dB3 transducer), 6 m (dB6), 10 m (dB10), 15 m (dB15), 25 m (dB25), 40 m (dB40)
ECHO PROCESSING	
Description:	DATEM (Digital Adaptive Tracking of Echo Movement)
OUTPUTS	
Analogue output:	Isolated output of 4-20 mA or 0-20 mA into 500Ω (user programmable and adjustable) 0.1% resolution
Serial comms:	RS232 via RJ11 port
Volt free contacts, number and rating:	6 form "C" (SPDT) at 5A at 240V ac
Display:	6 digits plus 12 character text, plus bargraph with level direction indicators, remote communicator identifier, and program/run/test mode indicators
ANALOGUE INPUT	
	4-20 mA source (N.B. Active Input on Request)
PROGRAMMING	
On-board programming:	By integral keypad
PC programming:	via conn for RS232 (RJ11 port)
Programming security:	Via password (user selectable and adjustable)
Programmed data integrity:	Via non-volatile RAM, plus backup, RS485 Modbus or Profibus DP V0 or V1
SUPPLY	
Power supply:	115V ac + 5% / -10% 50/60 Hz, 230V ac + 5% / -10% 50/60 Hz, dc 18 - 36V
DIGITAL INPUTS	
	7 NO or NC with 24vDC internal supply, available max 20mA

# Quantum:

## The Last Word in Level and Pumping Station Control

### Features

- Highly intelligent pump controller
- Automatically resets tripped pumps
- Time to spill calculation and warning
- Easy prompt led set up
- RS485 Modbus and Profibus DP V0 and V1 options
- 10 relay outputs and 7 digital inputs
- Pump efficiency alarm function
- Peak power tariff avoidance

Pulsar has taken the intelligent pump control built into the Zenith, to a new level with Quantum. It has all the features of Zenith but with extra capabilities and advantages. Quantum will provide alarms, including a unique alarm warning of 'time to spill' in critical areas, and reset tripped pumps automatically, so staff may never have to visit site just to reset a pump (pat. pending).

Quantum can be programmed to provide an alarm based on the time remaining before the station or well spills over. This is for instance vital for utilities, who face the risk of prosecution if a station pollutes the local environment.

The likelihood of a 'spill' depends both on the rate of change of the level and the operating efficiency of the pumps, which can be affected by failure, blockage or underperformance. If a pump has failed, the rate of change may not be important, because the level may well creep up slowly to reach a dangerous level. More important is to know how much time remains before a critical high level, or an overspill level, is reached. Quantum takes all the inflow and outflow rates of the station together and calculates the time remaining before a spill, warning via Modbus register or any other protocol or relay closure for the site operators to take remedial action.

In addition to the 'time to spill' feature, Quantum is also a fully-featured pump controller, using Pulsar's unique non-contacting ultrasonic technology including DATEM digital echo discrimination to provide rock-solid performance and sophisticated level management. The Tariff Guard software built into Pulsar's Quantum (and Zenith) controllers monitors well inflow and outflow rates to override the normal on/off levels of the control unit to keep pump usage to an absolute minimum during the high tariff period.

Quantum includes ten relays (digital outputs) and seven digital inputs. Digital inputs are used to detect the status of the pump trip circuit. If a pump has tripped, digital outputs can be assigned to provide a reset to the trip circuit (after a programmable time delay). Quantum counts the number of consecutive trips and the number of trips in a rolling 24 hour period. If any of these counts reach a predetermined maximum, the pump is considered to be faulty and the auto reset process is ceased. A digital output can be assigned to provide indication that a pump is faulty and site attendance is required.

The Quantum controller has optional RS485 digital communications (Modbus and optional Profibus DP V0 and DP V1) allowing the status to be monitored and the unit to be programmed remotely. Additionally it has the option of a large on board data-logging facility (256kb).

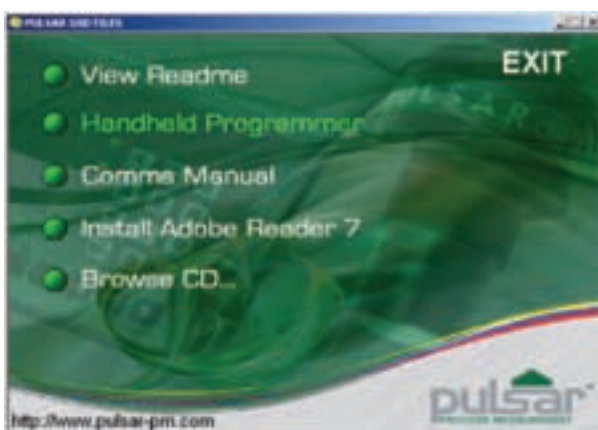

IMAGE OF THE REAR PANEL OF THE QUANTUM UNIT



# Technical Specification: Quantum

PHYSICAL:	
Weight:	Nominal 1.3kg
Case material:	Stainless steel and polycarbonate, flame resistant to UL94 V0
Transducer cable requirements:	Twin screened
Maximum separation:	1000m
Fascia mount:	200mm x 112mm frontage, 165mmx 105mm cut-out
OPTIONS:	
Digital communications:	RS485 Modbus or Profibus DP V0 or V1
ENVIRONMENTAL:	
IP rating:	IP64
Max. and min. temperature (electronics):	-20°C to +50°C
Flammable atmosphere approval:	Safe area: compatible with approved dB transducers allowing installation to zone 0 (see transducer specification sheet)
CE Approval:	EMC approval to BS EN 50081-1:1992 for emissions and BS EN 50082-2:1995 for Immunity, and to BS EN 61010-1:1993 for low voltage directive.
Power Supply:	115V ac +5% -10% 50/60Hz, 230V ac +5% -10%, 18-36V dc
PERFORMANCE:	
Accuracy:	0.25% of the measured range or 6mm (whichever is greater)
Resolution:	0.1% of the measured range or 2mm (whichever is greater)
Range:	Depending upon transducer, from 125mm to 40m
ECHO PROCESSING:	
Echo Processing:	Patented DATEM (Digital Adaptive Tracking of Echo Movement)
INPUT/OUTPUT:	
Volt free contacts:	10 in total; Relays 1-5 form C (SPDT) 5A, 240V ac, Relays 6-10 form C (SPDT) 3A, 240V ac
Digital Inputs:	7 NO or NC with 24V dc internal supply, available max 20mA
Analogue Output (adjustable), 0.1%:	Isolated output 4-20mA or 0-20mA into 500Ω (user programmable and adjustable)
Analogue Input:	Isolated input for loop powered device
Serial Output:	RS232 via RJ11 port
Display:	6 digits plus 12 character text, plus bargraph with direction indicators, remote Communicator identifier and program/run/test mode indicators
ANALOGUE INPUT:	
	4-20 mA source (N.B. Active Input on Request)
PROGRAMMING:	
On-Board Programming:	Standard with integral keypad
PC Programming:	Via RS232 (RJ11 port)
Programming Security:	Via password (user selectable and adjustable)
Programmed Data Integrity:	Via non-volatile RAM, plus backup



TYPICAL SET-UP SCREEN FOR PROFIBUS GSD FILES

# Product comparison:

	Functions			
	Zenith		Quantum	
	level	pump control	level	pump control
Six control/alarm relays	•	•		
Ten control/alarm relays			•	•
Compatible with all dB family transducers for 125mm to 40m measurement range	•	•	•	•
Liquids and solids	•	•	•	•
I.S. transducer (EEx ia) option	•	•	•	•
Fascia mount version only	•	•	•	•
<b>Alarm Functions on changing level to provide: (see Ultra 5 specification)</b>				
<b>Pump control functions: (see Ultra 5 specification)</b>				
<b>Advanced pump control functions:</b>	•	•	•	•
Tariff guard (high power cost avoidance)	•	•	•	•
Pump over-ride or inhibit via input	•	•	•	•
Digital inputs 7 off	•	•	•	•
Time to spill alarm			•	•
Pump auto-reset facility			•	•
Pump run-on	•	•	•	•
Power on/off delay	•	•	•	•
Pump start/stop delay	•	•	•	•
Pump exercising	•	•	•	•
Pump start variation	•	•	•	•
Storm control feature	•	•	•	•
Aeration control	•	•	•	•
Flush valve control	•	•	•	•
<b>Data logs:</b>				
Pump trip counts in 24 hrs			•	•
Pump running, run-on hours	•	•	•	•
Number of pump starts	•	•	•	•
Maximum and minimum recorded temperatures	•	•	•	•
Optional datalogging board for expanded logging capacity and Modbus or Profibus connectivity	•	•	•	•
Differential (using two transducers)	•	•	•	•
Penstock control on level difference	•	•	•	•

# pulsar

## Blackbox

Blackbox is Pulsar's component non-contacting ultrasonic level measurement range, designed to fit right into a distributed control system. A small control unit sits remotely on your plant, connected to an ultrasonic transducer. Simply set up from a hand held programmer or PC interface using Pulsar's 'Blackbox PC' software, you select the output type that you need and the right transducer for the application from Pulsar's dB range, giving you a measurement range from 125mm through to 40m on solids or liquids.

Simple does not mean unsophisticated – the blackbox range enjoys the benefit of advanced DATEM echo processing for a reliable, consistent result.



# Blackbox Controllers:

## Level measurement made simple

### Features

- Compact low cost intelligent controllers
- Will operate on all dB transducers up to 40m range
- Solids, powders and liquids level measurement
- Separation from transducers up to 1000m using standard 2 core screened cable

All standard Blackbox units share a common IP67 enclosure with 3 cable glands fitted. A flashing LED indicates healthy operation. Programmed through PC using supplied software or Pulsar hand held programmer using RS232 via RJ11 port.

## Blackbox 1 30

### Level

Non-contacting level measurement featuring a 4-20mA output, which can be supplied isolated or non isolated, proportional to level and two alarm or control relays.



## Blackbox 1 33

### Level Control

Two control or alarm relays, with simple 0-5V output proportional to level to drive a local display. Simple 2 pump control with alternation is also included in the 133.



## Blackbox 1 34/1 35

### Level Comms

Blackbox Level Comms retains the alarm relays of Blackbox 133, and adds an RS485 port for digital communications.

Modbus (code 134), Profibus DP V0 or V1 (model 135)



## Blackbox 1 36

### Level CSO

Pulsar's blackbox 136 CSO is a sophisticated ultrasonic system specifically designed for use with batteries to provide non-contacting monitoring of level or overflow events, with exceptionally low power consumption to maximise battery life in remote locations.



# Blackbox Calibration:

The standard Blackbox units have two choices of calibration

The first method is via PC software, Blackbox PC, a CD is provided free of charge with each unit, although an additional interconnect cable will be required. Should this choice be selected an additional connector between the PC being used to calibrate the instrument and the Blackbox itself would need to be purchased. One connector can be used, to calibrate any number of units whichever model they are. This connector attaches to the RJ11 RS232 port within each Blackbox controller and has a choice of a serial connector back to a PC or a USB port. The part number for cable with USB port is: PCLEAD-U and the part number for cable with serial connector is: PCLEAD-S.

The second method of calibrating a number of Blackbox controllers is to use the removable hand held programming unit shown. This can be purchased and be used for any number of Blackbox controllers of whatever type, and provides an easy and immediately visual feedback to the user. Once calibration is complete just remove the cable from the RJ11 port and all parameters will be retained in the controller and it will revert to the run mode.

**Programming options include: PC software download, removable hand-held programming unit.**



REMOVABLE HAND-HELD PROGRAMMING UNIT CONNECTED TO BLACKBOX



FOOD PROCESSING TANK LEVEL



BLACKBOX PC SOFTWARE SUPPLIED ON A CD AND OPTIONAL CABLE CONNECTING FROM RJ11 TO PC



MINERAL OIL TANK LEVEL



BLACKBOX ON MIXING TANKS WITH AGITATORS



# Blackbox Display:

Blackbox with integral display - component non-contacting level monitoring with integrated readout

## Features

- Clear backlit display
- Keypad with 'hot keys'
- Easy set up

Blackbox is Pulsar's component non-contacting ultrasonic level measurement and control range, fitting between the self-contained IMP and the high specification Ultra 3 and Ultra 5 for volume monitoring, pump control and open channel flow measurement. Blackbox units are available with a variety of output options: 2 control relays, 4-20mA, or RS485 digital output (see Blackbox 134/5 information). Programming options include: PC software download, removable hand-held programming unit and now the further option of an integral keypad and display.



The integral keypad and display is available for any unit in the blackbox range with the exception of the blackbox 136 CSO.

The integrated keypad and display means that you have complete flexibility in your control application, providing a local display for those applications that require local indication. Alternatively, blackbox with integral keypad and display provides an economical alternative for simple level measurement or control applications.

Blackbox units are compatible with Pulsar's complete range of transducers, giving a range extending from 125mm right through to 40m, on solids, powders or liquids. The Blackbox range benefits from DATEM (Digital Adaptive Tracking of Echo Movement) digital echo processing, providing unrivalled performance particularly on difficult applications.



SHOWS THE BLACKBOX DISPLAY IN SITU

## Technical Specification: Blackbox Display

PHYSICAL	
<b>Dimensions:</b>	130mm x 130mm x 60mm
<b>Weight:</b>	Nominal 0.65kg
<b>Enclosure:</b>	ABS Base with polycarbonate lid
<b>Programming:</b>	integral keypad or RS232 interface using optional software or hand-held programmer
ENVIRONMENTAL	
<b>Flammability rating UL94HB:</b>	Fitted with 3 x M20 nylon cable glands for 6-12mm cable. IP rating: IP66
Electronics should be mounted in a safe area. Please see detailed specification for full details of EMC approvals etc.	
<b>Max/min temperatures (electronics):</b>	-20°C - +50°C
<b>Measurement range:</b>	125mm - 40m depending on transducer
PERFORMANCE	
<b>Accuracy:</b>	0.25% or 6mm whichever is greater
<b>Resolution:</b>	0.1% or 2mm whichever is greater
<b>Display:</b>	2 x 12 alpha numeric (backlit)
ECHO PROCESSING	
<b>Programming security:</b>	Via Passcode (user selectable)
<b>Outputs:</b>	2 volt-free contacts, form "C" SPDT rated 2A at 240V AC, RS232 for programming and data
<b>Comms:</b>	RS232 via RJ11 port standard and optional RS485 providing digital communications by 134/5 units



# Blackbox:

## Modem

The ultimate distributed stock monitoring and control system, Blackbox Modem features an built-in GSM modem that provides SMS (text) messages in response to low level or re-fill points, meaning you can monitor stocks across a site, a city or a country – plan your transport efficiently, save time and money and most importantly, keep your customers happy.

Blackbox modem features superb digital echo processing to give reliable level measurement over anything from 125mm to 40m on solids, powders or liquids, making it perfect for measurement of almost any kind of bulk material.

“Blackbox modem” includes a GSM modem, which is simply configured via a PC set-up to provide a mobile phone SMS text message either when stocks reach a user configured “restock” point or at user-set intervals. That allows the supplier to plan properly for restocking, decide the most efficient routes for delivery vehicles in advance, and perhaps most importantly, avoid the dreaded “I’ve run out – can you be here in ten minutes?!” phone calls.

Blackbox modem is aimed at companies with distributed stocks of material that need replenishment on a regular basis, for example: cement silos in construction sites over a wide area, chemical tanks based on customers’ premises and so on. Alternatively, Blackbox modem is ideal for large sites where it is important to maintain a stock level in strategic areas, or for environmental protection applications where high levels or overflow conditions are critical. The GSM modem can also act as a wireless connection to Pulsar’s Blackbox PC software for diagnostics and programming.

### Blackbox Modem is available in 4 versions:-

**Modem Level 130:** which also features a 4-20mA output for local display of level;

**Modem Level Control 133:** which offers two mechanical relays (Type C, 230V 2A SPDT) for alarm or control functions.

**Modem Level Comms 134/5:** with Modbus or Profibus DP V0 or V1 digital comms on board.

Two software packages are available - BlackboxPC, which provides set-up facilities for the Blackbox unit and allows the user to fully set up the unit, view echo profiles and perform diagnostic checks. SMS Server is specifically designed for collating SMS data from multiple units in the field. Use a Pulsar GSM modem at a PC to receive and record the data.



## Features

- SMS text alert on level
- SMS server software monitors and logs many tanks for levels

## SMS Server software

SMS Server shows you all your sites at a glance on your PC screen. A simple colour-coded mimic tells you when a site has reached a re-order point or is at a dangerously low level, so you can make the right decisions about restocking materials and programming vehicles for the best possible efficiency - saving time, resources, manpower and energy.

SMS Server is easy to set up and runs on a standard PC connected to the compact Pulsar GSM modem.



# Blackbox Modem:

## Blackbox with integrated GSM Modem

The system\* is dependent on SIM card used; it can be either “data” enabled or standard SMS type (Voice/PAYG).

If the SIM card is standard voice type, the Blackbox Modem (1) can send SMS text messages on alarm to designated mobile phones, or customer can install Pulsar SMS server on a PC connected to a PC modem (2). The SMS server software can collect data and reports and present data in a graphical format, also this data can be saved into Excel format. This is a many to one connection.

If SIM card fitted on the remote site is a “data” type then, using Blackbox PC software on a local PC with modem (2), this allows getting and setting of parameters and getting traces, this is a one to one transparent connection from Blackbox PC software to the remote unit.

\*Coverage dependent on network.

1: The modem is a quad band modem GSM 900/DCS 1800/GSM 850/PCS 1900 fitted in larger enclosure with Blackbox processor board and PSU.

2: The modem is a quad band modem GSM 900/DCS 1800/GSM 850/PCS 1900 fitted in larger enclosure with PSU.



FIGURE 1: THE OPERATIONS OVERVIEW SCREEN

The bars here show the most recent levels for each “station”. Green bars mean stock levels are OK, yellow show that level is below a warning threshold but above the alarm level, and red shows that levels are below an alarm threshold.

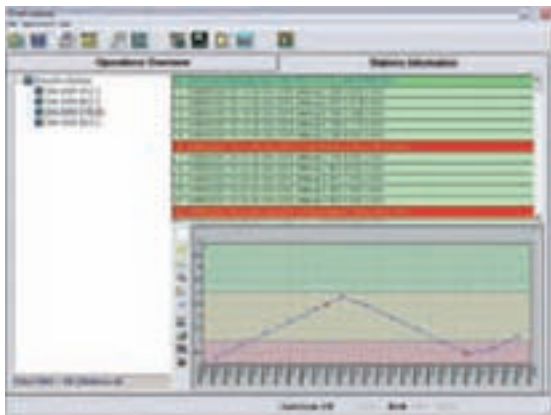
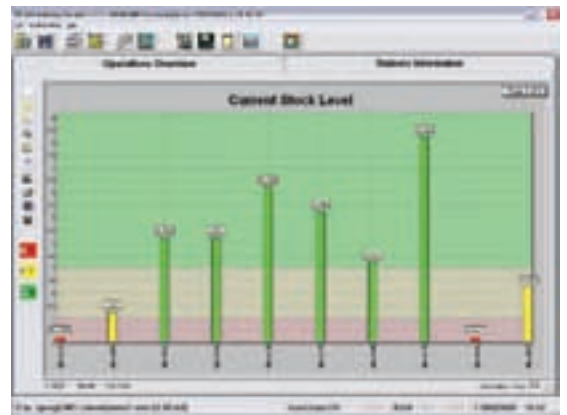

FIGURE 2: STATIONS INFORMATION SCREEN

More detailed information for each station is available here: the type of site, the number of reports received from each site, the number of alarms received are all displayed, and a graph showing the trend data from each station helps decisions to be made on restock frequency etc. All the data can be exported in .csv format for additional analysis or reporting in spreadsheets or other programs.



## Technical Specification: Blackbox Modem

### PHYSICAL:

<b>Enclosure:</b>	polycarbonate lid, ABS base, IP66/67
<b>Dimensions:</b>	130mm x 180mm x 60mm
<b>Power requirement:</b>	30W max
<b>Transducer:</b>	compatible with the dB range of transducers, 125mm to 40m measurement range
<b>Flammable atmosphere:</b>	Blackbox unit must be mounted in safe area, see transducers data for Zone approvals

**Brief Specification:** (NB: for full specification see Blackbox specification below):

# Blackbox 136:

## Level CSO

**Pulsar's blackbox 136 CSO is a sophisticated ultrasonic system specifically designed for non-contacting monitoring of level or overflow events, with exceptionally low power consumption to maximise battery life in remote locations and built in data logger.**

Blackbox 136 CSO provides a self-contained solution to level and event recording and with the ability to supply a voltage output to an external monitoring or telemetry outstation if required. Blackbox 136 CSO may be programmed to provide level measurement using the optional hand-held calibrator or using Blackbox PC calibrator software, a copy of which is supplied with the unit.

If data logging is a requirement, the optional CSO log software is available both to set up the unit and download and analyse the logged data. The software includes powerful graphing, data analysis, export and print functions so that the history of the site can be easily understood and displayed.

136 CSO may be set to read level continuously, or in order to prolong battery life, may be set to wake up to take readings at user-defined intervals (1-99 minutes). Each data record is internally logged and also supplied as a 0-5v output. On standby, 136 CSO is ready to be polled by an external data logger or telemetry outstation for the retrieval of information.

Wake up intervals may also be varied automatically. For instance, if the level approaches a critical point, the interval between measurements can be reduced on even set to run the system continuously so that more detailed records of the event are available. The new interval will be maintained until the level returns to normal values and then the system reverts back to the previous wake up interval.

Should a weir or other flow structure be available in the CSO then the Blackbox 136 can totalise 'spill volume' through this structure. Not only will the 136 CSO unit log the day, time and duration of any 'spill event' it logs the quantity too.

Flexibility and adaptability to specific site requirements are key features of the 136 CSO system.

## Features

- Low power with large internal data log
- Flexible and variable wake up periods
- Can be externally polled for logged data
- Battery life calculator included in CSO Log software



**LEVEL CSO MOUNTED ON BATTERY PACK INSIDE A BOLLARD**

# Blackbox 136 Level CSO

## Software

### Features

- CSO Log easy set up software optional
- Multi parameter logging feature of level/ day/ time/ duration/volume spill
- Volume of spill over weir calculation included
- Plug in set up and leave

CSO log software is a powerful way to record and manage accumulated data. CSO log software provides both set-up of Blackbox 136 CSO units and the download and analysis of internally logged data for graphing and output. PC connection to the system is from a PC RS232 (COM) via the 136 CSO's on-board RJ11 port.

The 136 CSO unit may be completely calibrated, either in advance or on site. As with all Pulsar equipment, set up parameters are logical and intuitive. All you have to do is set up the physical dimensions of the application and tell the unit what you want to measure and how often. Data logging is flexible; you select the information you wish to log and the logging interval. The unit will let you know how many months storage is available and any aspect of measurement or logging may be adjusted to suit the reporting requirements. Depending on measurement frequency, 136 CSO is easily capable of recording twelve months of data and may be set so that new data overwrites the oldest where required.

Logged site data is downloaded to a PC file through the same cable connection used for programming. In addition, all programming parameters may be downloaded for backup or repeat set up (cloning).

The powerful graphical analysis tools in CSO log software put the story of the site at your fingertips. You can see how all your logged data has varied over time, clearly plotted and available to be "cut and pasted" into a word processor or other reporting program. A standard CSV file may be exported to a spreadsheet or data analysis package or archive.

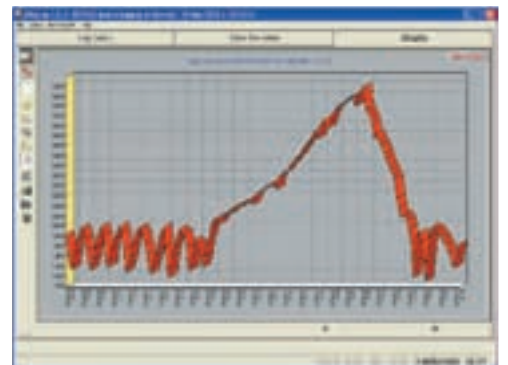
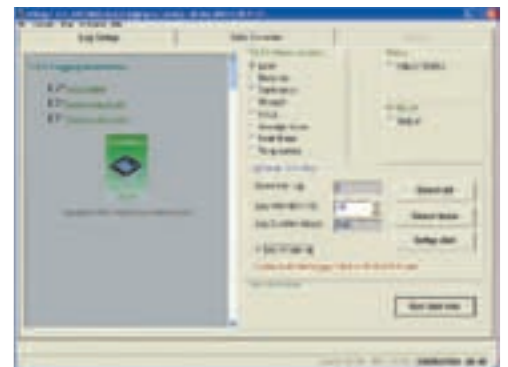
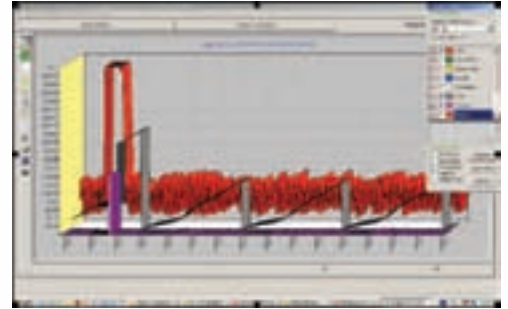

dB3 WITH DRIP SHIELD  
MOUNTED IN CSO CHAMBER

## Technical Specification: Blackbox

### Product Functions

	Blackbox				
	130 Level	133 Level Control	134 Level Comms	135 Level Comms	136 Level CSO
115/230 VAC	•	•	•	•	
10-28v DC	•	•	•	•	•
4-20mA o/p Max 1K	•				
0-5V o/p Min Load 10K		•			•
2 relays 230V, 2A Form C (SPDT)	•	•	•	•	
RS232 RJ11 port	•	•	•	•	•
RS485 Modbus			•		
RS485 Profibus DP V0 or V1				•	
Logging					•



WATERPROOF CONNECTION (TO IP67) MOUNTED ON UNIT'S ENCLOSURE INSTEAD OF RJ11 PORT INSIDE.

### PHYSICAL

<b>Weight:</b>	nominal 0.65Kg
<b>Enclosure:</b>	ABS Base with polycarbonate lid, flammability rating UL94HB
<b>Cable entries:</b>	3xM20 nylon cable glands suitable for 6-12mm cable

### ENVIRONMENTAL

<b>IP Rating:</b>	IP66/67
<b>Max/min temperature (electronics):</b>	-20°C - +45°C
<b>Flammable atmosphere approval:</b>	All blackbox units must be mounted in a safe area.

### PERFORMANCE

<b>Accuracy:</b>	0.25% of measured range or 6mm (whichever is greater)
<b>Resolution:</b>	0.1% of the measured range or 2mm (whichever is greater)
<b>Range:</b>	Dependent on transducer. Nominally 125mm to 40m. Compatible with all dB transducers

### ECHO PROCESSING

<b>DATEM:</b>	(Digital Adaptive Tracking of Echo Movement)
<b>Programming security:</b>	Via Passcode (user selectable)
<b>Programmed data integrity:</b>	Via non-volatile RAM

### POWER SUPPLY

115V ac +5% / -10% 50-60Hz
230V ac +5% / -10% 50-60Hz
dc 10-28V
10W maximum power (typically 5W)

### HAND HELD PROGRAMMER

Power supplied via Blackbox RS232 RJ11 connector

### FUSES

50mA at 200 - 240V ac
100mA at 90 - 120V ac

### Dimensions: Blackbox Standard

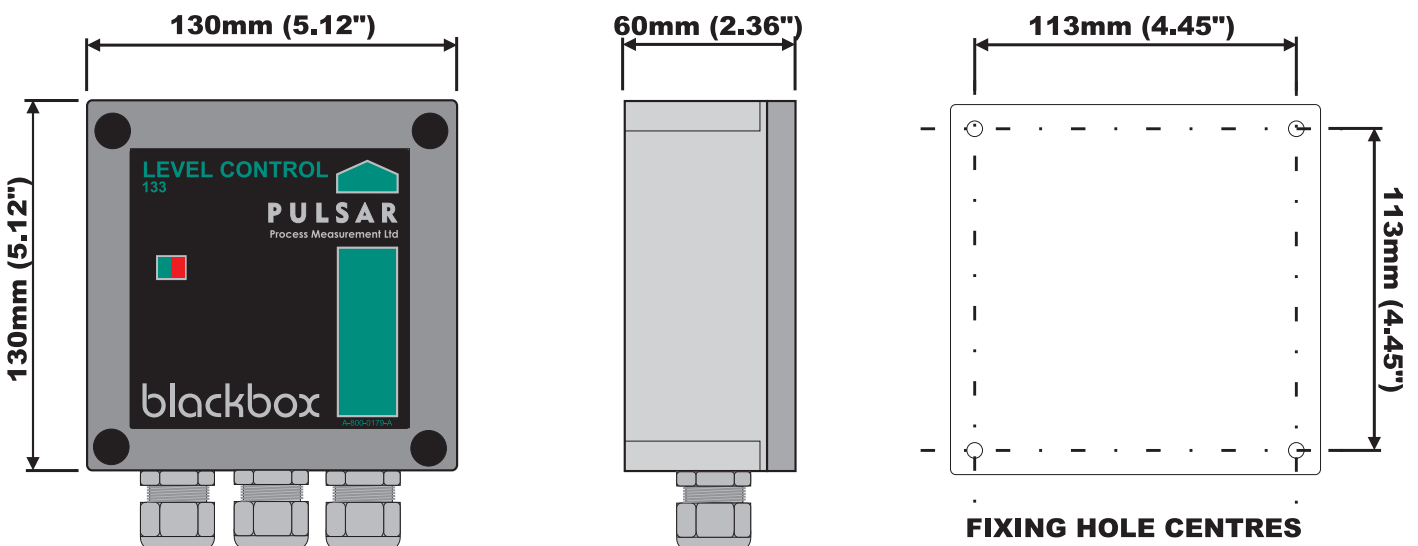

# pulsar

## IMP

### IMP Standard 2/3 Wire page 47-48

The IMP range offers a combined transducer and controller in one self contained unit. Non-contact level measurement of liquids or solids. Has a choice of 2 or 3 wire configuration. Up to 10m range.

### IMP I.S. page 49

IMP is also available in I.S. configuration to ATEX and IECEx. 2 wire loop powered easy set up

### IMP PC Software page 49

IMP PC software allows parameter access and echo trace viewing on screen. This easy-to-use software package stores calibration details of each IMP.

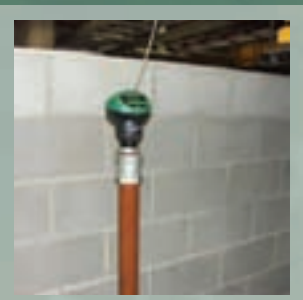
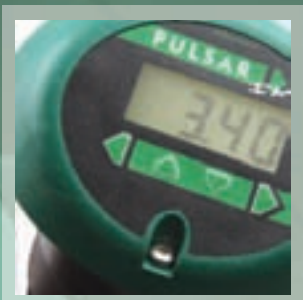

# IMP:

## Self-contained ultrasonic level measurement without compromise

Pulsar's IMP range is non-contacting ultrasonic level measurement without compromise. Compact, low-profile self contained units with the benefit of digital echo processing specially designed for IMP. Simple programming without affecting the IP rating via the integral keypad or using IMP PC, IMP's own PC software that lets you program the unit, view and download echo profiles and parameters.

There is an IMP to suit your application. 3m, 6m and 10m range versions are available and each can be wired for 2 wire or 3 wire operation. 2-wire Intrinsically Safe (I.S.) versions are also available. All IMPs feature LCD displays and digital temperature measurement and compensation. Imp also has 2 relay outputs as standard.

You can use IMP wherever you need reliable non-contacting level measurement: digital echo processing means IMP is perfect for solids or liquids. Sumps, tanks, silos. Anywhere you need a display telling you the level, or an analogue output to interface with your site control system or drive a display.

When used on battery power for intermittent (wake-up) applications, IMP's high speed boot up of circa 3 seconds maximises battery life. For example, if an IMP were switched on every 15 minutes for a 3 second reading, average current is a mere 40 $\mu$ A.

Active and passive (sourcing and sinking) analogue outputs assist with system integration, especially when retro-fitting into older installations.

### Features

- Compact self contained level measurement
- Calibrate without compromising the IP67 rating
- Simple menu led set up
- High power and narrow beam angles



IMP ON CHEMICAL TANK



STANDARD IMP FACE



## Features

- 1.5" universal thread (2" on IMP 10)
- Agitator avoidance as standard
- 200mm deadband on IMP 3
- PVDF Nose option

## IMP Variants

VARIANTS:	IMP 3	IMP 6	IMP 10
<b>Range:</b>	200mm - 3m	300mm - 6m	300mm - 10m
<b>2 / 3-wire configurable IMP:</b>	11-30 volts dc / 4-key user interface / LCD adjustable backlit display Digital temperature measurement / 2 alarm relays (1A 30V) / IMP PC software download / Digital echo processing.		
<b>2-wire I.S. IMP:</b>	I.S. certificate to ATEX EEx ia IIC T4 and IECEx / 4-20mA loop powered / 4-key user interface / LCD display / Digital temperature measurement / Digital echo processing.		



PVDF NOSE CONE OPTION

The full IMP range is available with the wetted parts in PVDF build alternative for corrosive or aggressive applications. The picture below shows a PVDF nose cone on an IMP 6 unit.



INSIDE OF I.S. IMP (ATEX and IECEx)



INSIDE OF STANDARD 2/3 WIRE IMP

IMP ON A MIXING TANK



IMP ON A LIQUID LIME TANK





# I.S. IMP:

## I.S. IMP and IMP PC Software

### IMP applications

You can use IMP wherever you need reliable non-contacting level measurement: digital echo processing means IMP is perfect for solids or liquids. Sumps, tanks, silos. Anywhere you need a display telling you the level, or an analogue output to interface with your site control system or drive a display.

When used on battery power for intermittent (wake-up) applications, IMP's high speed boot up of circa 3 seconds maximises battery life. For example, if an IMP were switched on every 15 minutes for a 3-second reading, average current is 40µA (3 seconds "live" @ 12mA averaged over 15 minutes) .

The presence of active and passive (sourcing and sinking) analogue outputs assists with system integration, especially when retrofitting into older installations.

### IMP PC

**IMP PC** is optional software that extends IMP's capabilities, allowing you to:

- **Download, analyse and store echo profiles.**  
A great way to see exactly what is happening in the application. Fine tuning for ultimate performance.
- **Set-up** IMP. All programming parameters are instantly visible in the IMP PC programming screens. Program the IMP unit on a desktop before installation, or clone a number of IMPs to save valuable time.
- **Updates.** Future-proof your IMP! Pulsar's policy of continuous improvement means that we never stop developing our products. IMP PC allows new firmware to be installed into your IMP units without even removing them from the application.
- **Flow measurement.** A flow curve may be added within IMP PC to configure for simple level to flow linearisation

### Simple to install

The compact IMP is only 175mm high with a 130mm diameter. Cable glands are provided and IMP can be simply screwed into a 1.5" or 2" universal fitting (a 1.5" to 2" adaptor is available). High transducer power and tight beam angles, together with Pulsar's digital echo processing, makes IMP ideal for many "difficult" applications such as dusty or foamy environments, or where a tank has unavoidable intrusions. The integral display makes programming

IMP extremely straightforward. IMP can be completely set up, without compromising the IP rating, using the integral keypad alone with no need for a PC. Optional IMP PC software makes it easy to fine tune IMP's performance and "clone" any number of IMP units to the same settings if, for example, they are being used on a tank farm. Please note that PC interface is not included on I.S. IMP variants.

## Features

- **High Specification I.S. version**
- **Up to 10m range available**

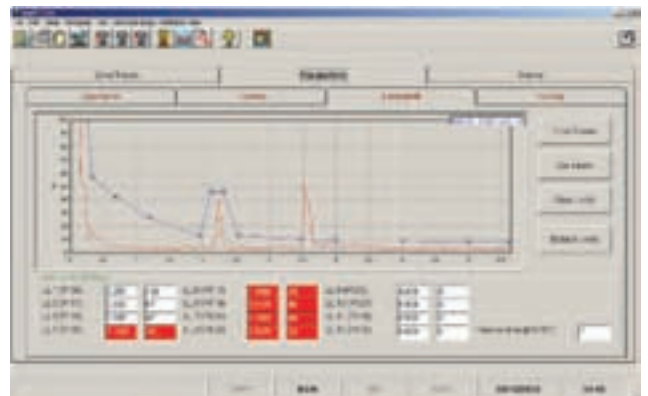

IMP PC DIAGNOSTICS

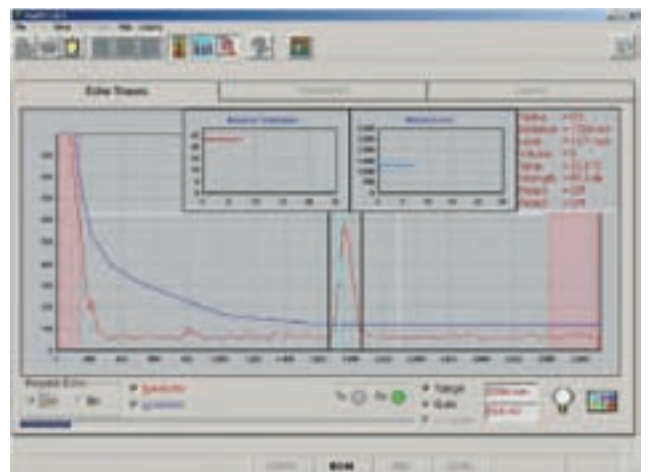

IMP PC ECHO TRACE



IMP PC PARAMETER SETUP

## Technical Specification: IMP

PHYSICAL:			
<b>Dimensions:</b>	175mm overall height x 130mm diameter		
<b>Cable entry:</b>	2 off 16mm cable glands 3.5 - 10mm cable dia.		
<b>Mounting:</b>	1.5" (3m and 6m range versions), 2" (10m version) universal thread - suits BSP and NPT, parallel and tapered		
<b>Weight:</b>	approximately 1Kg		
ENVIRONMENTAL:			
<b>Temp range (process):</b>	-40°C - +85°C (-40°C - +80°C for I.S. version)		
<b>Temp range (ambient):</b>	-20°C - +65°C		
<b>IP Rating:</b>	IP67		
VARIANTS:			
	IMP 3	IMP 6	IMP 10
<b>Beam angle (-3dB half power):</b>	<10° inclusive	<10° inclusive	<10° inclusive
<b>Operating frequency:</b>	125kHz	75kHz	41kHz
<b>Measurement range:</b>	0.2m-3m	0.3m-6m	0.3m-10m
PERFORMANCE:			
<b>Digital echo processing:</b>			
<b>Input voltage range:</b>	11 - 30V (17 - 28V for I.S. version), 3.5 - 22mA		
<b>Accuracy:</b>	± 0.25% or 6mm (whichever is greater)		
<b>Resolution:</b>	± 0.1% or 2mm (whichever is greater)		
<b>4-20mA outputs:</b>	resolution 5 micro A (both active and passive outputs)		
<b>Temperature compensation:</b>	via internal temperature sensor (±0.5°C accuracy) Level and volume conversion are installed allowing linearisation for tank shapes		
IMP MAY BE WIRED AS EITHER 2-WIRE OR 3-WIRE, GIVING THE FEATURES BELOW:			
<b>2-wire configuration:</b>	RS232 (RJ11 port) connection for diagnostics and software updates 4 digit LCD display 4 button keypad for parameter entry <b>Power consumption:</b> 3.5 - 22mA Passive 4-20mA output		
<b>3-wire configuration (additional to 2-wire):</b>	Backlit LCD display 0-10V analogue output <b>2 relays:</b> single pole two way, 1A 30VDC/AC Power consumption with relays energised <60mA (less 12mA/relay not energised) Active and passive 4-20mA outputs		
<b>2-wire I.S. version:</b>	Intrinsically safe to ATEX EEx ia IIC T4 and IECEx. NB: I.S. IMP is identified by black cap to housing instead of green. Does not include RS232 interface.		
<b>PC Interface IMP PC:</b>	All parameters can be accessed and changed through IMP PC software. Echo traces may be viewed on screen. NB: IMP I.S. does not offer this feature.		



IMP CONTROLLING SCREEN HEIGHT



IMP CONTROLLING GATE HEIGHT



IMP MONITORING IN A CSO CHAMBER

# pulsar

## Sludge Finder 2

### Sludge Finder 2

page 52

Is a proven effective sludge blanket interface monitor in both waste water and industrial applications. Sludge Finder 2 provides a continuous level indication and 4 – 20 mA output of interface height from the tank bottom along with relays for alarm or control use . Sludge Finder 2 monitors SBR tanks, primary or secondary settlement tanks down to 0.5% density.

### Prompt Led Set Up

page 53

Easy drop down menu allows quick set up, the clear large display offers a choice of menus and the interface echo can be constantly seen if needed.

### Self Cleaning Viper Transducer

page 54

The Viper transducer complete with a sweep clean wiper removes dirt and air from the transducer face. A second transducer may be added to the controller giving two channel ability if needed. The second transducer may be a through air ultrasonic unit, enabling the second channel to monitor level of liquid or solids, particularly useful in mineral or mining applications.

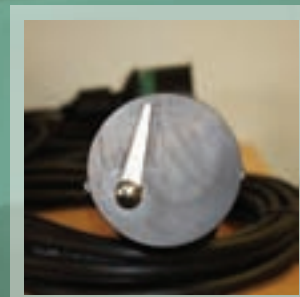
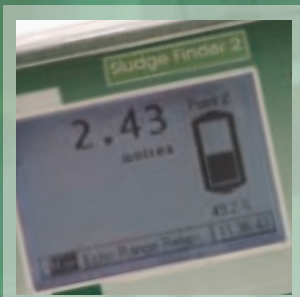

# Sludge Finder 2:

## Sludge interface monitor

### Features

- Continuous single or dual channel level control choice
- High frequency gives high reliability long term
- Self cleaning transducer removes need for regular inspection
- SBR tank applications can be monitored
- Easy set up, via drop down menu on large clear display

**Pulsar's Sludge Finder 2 is a versatile, accurate and reliable solution to the problem of accurately measuring interface levels in primary or secondary settlement tanks and SBR systems. Operating ultrasonically through liquid, Sludge Finder 2 uses proven echo processing algorithms to identify the sludge interface level by state of the art digital echo processing techniques found only in this unit.**

Sludge Finder 2's unique Viper transducer is immersed in the liquid, emitting a high frequency ultrasonic pulse down towards the sludge interface. The pulse reflects from the interface of the denser material back to the Viper transducer face. This echo is analysed by the controller unit providing a depth reading and an analogue output proportional to the height of the interface above the vessel bottom.

Sludge Finder 2 uses a self-cleaning underwater acoustic sensor that results in continuous, reliable sludge level measurement. You can reduce sludge pumping, optimise dosing and let your staff concentrate on other things.

### Multiple Tanks, Multiple Applications

Sludge Finder 2 will operate with one or two transducers: you can mix and match Sludge Transducers and Pulsar's main dB transducer range to give astonishing versatility. Manage two clarifiers/thickeners, or one clarifier plus an ultrasonic level application from a single unit, providing flexible, economical control and a single connection point for system interface.

Sludge Finder 2 features a microprocessor and a multifunction display showing blanket level, complete echo profile, alarm points, tank depth and multiple tank status.

### Use Sludge Finder 2 in:

- Primary and secondary settlement tanks
- Clarifiers
- Stationary and travelling bridge applications
- Gravity thickeners
- Reactor clarifiers
- DAF thickeners
- Sequential batch reaction tanks
- Industrial process thickeners

### Versatile outputs

Sludge Finder 2 features 4-20mA isolated outputs for each channel, with optional RS485 connection (Modbus or Profibus). Six control relays are included (5A rated), independently assignable to any channel. An optional radio modem with a 500m line-of-sight range may also be specified.

### The hygienic solution

Remote measurement with Sludge Finder 2 means you can put an end to tedious, time consuming, potentially unhygienic and hazardous manual measurements using gap switches or vacuum probes.

### Self-cleaning transducer

Sludge Finder 2 is designed to be maintenance free. Sludge Finder's Viper transducer is a single beam ultrasonic unit immersed just below the liquid surface. A wiper blade sweeps the transducer face, ensuring that it remains clean. The Viper transducer may be positioned up to 200m from the control unit and has a measurement range of 0.3 to 10m.

Accuracy is 0.25% of the measured range. A tight 6° beam angle and sophisticated echo processing algorithms makes sure that

Sludge Finder 2 deals with difficult tanks and rotating equipment with ease.



# Sludge Finder 2:

## Prompt led set-up

### Easy installation and set-up

Sludge Finder 2 is simply installed and the transducer cable can be easily extended with twin pair screened cable. To program Sludge Finder 2, the operator enters operating parameters via a menu driven operator interface and the Sludge Finder 2 automatically tracks to the blanket interface. Sludge Finder 2's operator interface consists of several screens that make setting up the unit straightforward and communicates information about the process quickly, clearly and concisely.

TYPICAL SCREEN SHOTS THROUGH MENU

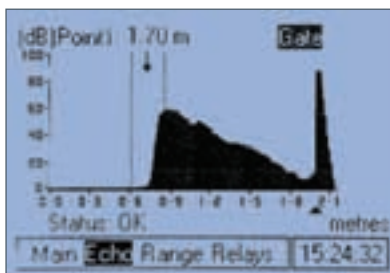
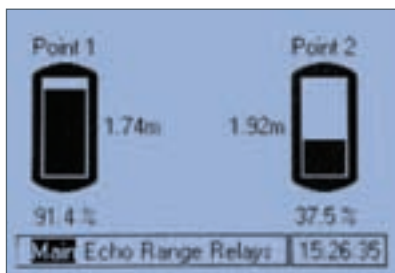
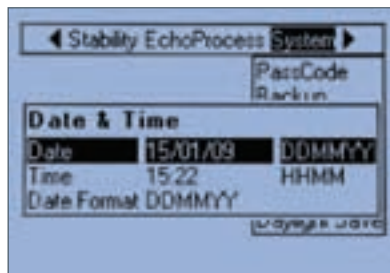
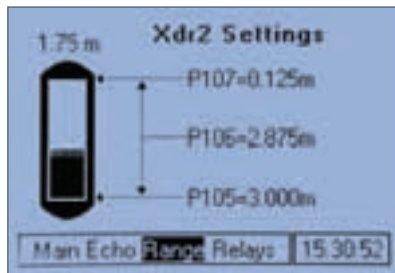
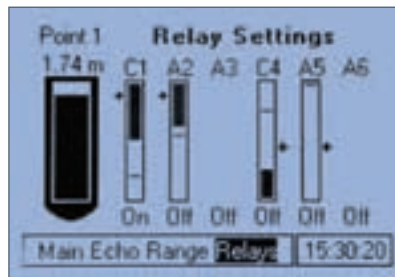
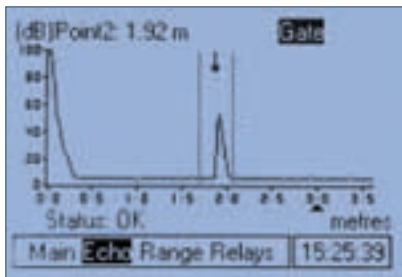
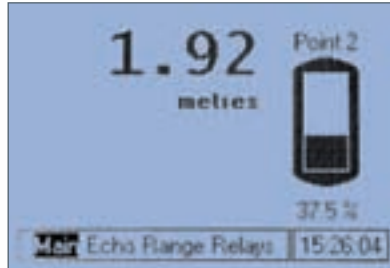

### Features

- Relay choices for alarm or pump control function
- Reliable monitoring down to 0.5% density
- Second transducer may be interface Viper transducer or an air transducer for liquids or solids level measurement
- 200m separation distance between Viper and controller using standard cable

A TYPICAL ECHO PROFILE VIEWED ON OPTIONAL SLUDGE PC SOFTWARE

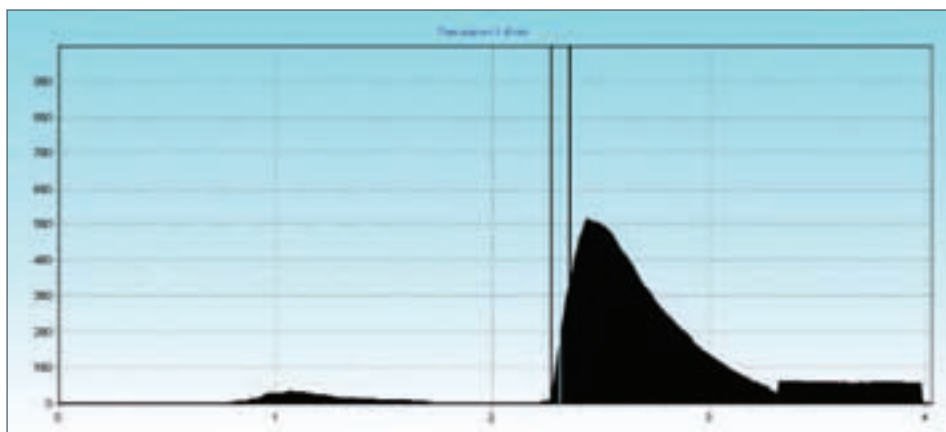

# Sludge Finder 2:

## Viper Transducer

### Features

- Self-cleaning transducer reduces maintenance
- Keeps algae and other growth off the face
- Flexible transducer arm option, allows rotating bridges to be used
- Mounting bracket options available

### Self-cleaning transducer

The Viper transducer is designed to operate continually immersed in liquid, and features an oscillating wiper blade to keep the face free of algae or bacterial growth that could otherwise affect performance. The wiper also effectively clears air bubbles from the transducer face, while the 0.2mm gap between the wiper and the transducer face makes sure there is no wear between the surfaces.

The sweep action of the wiper discourages 'hair' build up, ensuring that the shaft does not lock up over time.



VIPER MOUNTED BEHIND SURFACE SKIMMER AND IN FRONT OF ROTATING BRIDGE



FRONT VIEW OF VIPER FACE SHOWING WIPER

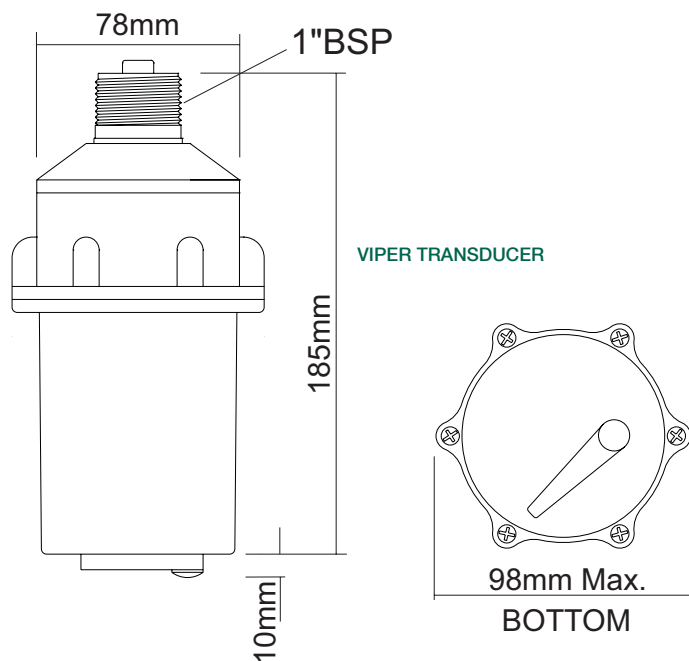

# Technical Specification: Sludge Finder 2

PHYSICAL:	
<b>Wall Mount:</b>	
<b>External dimensions:</b>	235 x 184 x 120 mm
<b>Weight Nominal:</b>	1 kg
<b>Enclosure material/description:</b>	Polycarbonate, flame resistant to UL94-5V
<b>Cable entry detail:</b>	10 cable entry knock outs, 5 x M20 and 1 x M16 underside, 4 x PG11 at rear
<b>Transducer cable extensions:</b>	2 x twin pair with overall screen
<b>Maximum separation:</b>	200 m from transducer to transceiver
ENVIRONMENTAL:	
<b>IP Rating (Wall):</b>	IP65
<b>Max. and min. temp. (electronics):</b>	-20 °C to +50 °C
<b>CE approval:</b>	2004/108/EC EMC approval 2006/95/EC low voltage directive
SONAR (INTERFACE) PERFORMANCE:	
<b>Accuracy:</b>	0.25% of the measured range or 10 mm (whichever is greater)
<b>Resolution:</b>	0.25% of the measured range or 10 mm (whichever is greater)
<b>Max. range:</b>	10m
<b>Min. range:</b>	0.3m
<b>NB:</b> Please refer to separate literature for dB transducer performance if using an 'air' application.	
OUTPUTS:	
<b>Viper material:</b>	Body in black Valox 357 with a 316 wiper blade and shaft
<b>Analogue output:</b>	2 off Isolated output (to 150V) of 4-20 mA or 0-20 mA into 1kΩ (user programmable and adjustable) 0.1% resolution
<b>Serial output:</b>	Half Duplex RS232
<b>Volt free contacts:</b>	6 form "C" (SPDT) rated at 5A at 240V AC
<b>Display:</b>	192 x 128 pixel illuminated graphical display. Fully programmable display options. Integral keypad with menu navigation keys
<b>Radio Modem (optional):</b>	4 – 20mA using wireless exempt frequencies
<b>Maximum range:</b>	500m line of site
<b>Communication bus (optional):</b>	RS485 Modbus RTU/ASCII or Profibus DP V0 or V1
PROGRAMMING:	
<b>On-board programming:</b>	By integral keypad
<b>PC programming:</b>	Via RS232 RJ11 port
<b>Programming security:</b>	Via passcode (user selectable and adjustable)
<b>Programmed data integrity:</b>	Non-volatile memory
SUPPLY:	
<b>Power supply:</b>	Universal 100 - 240VAC 50/60Hz DC 22 - 28V 14W maximum power (typically 11W) Fuse 2A slow blow

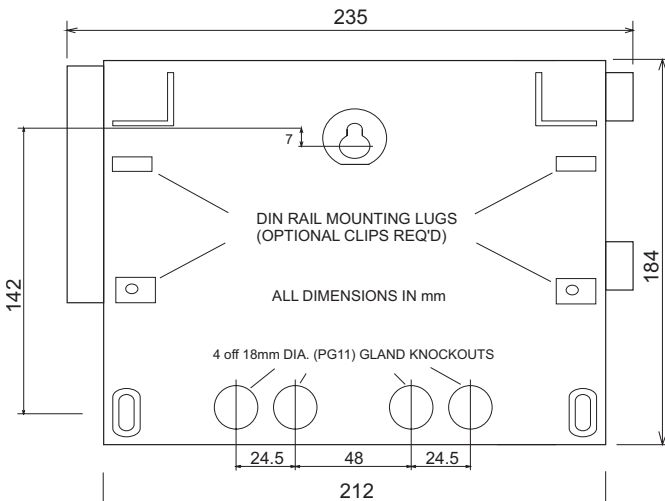

ENCLOSURE DIMENSIONS AND KNOCKOUT DETAILS

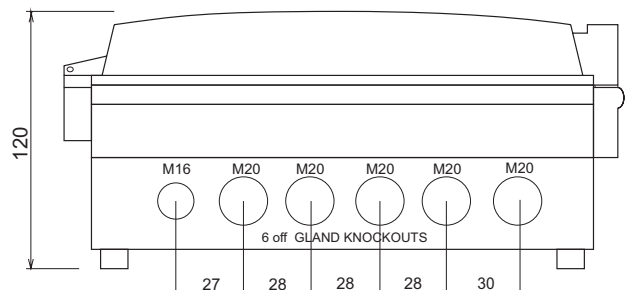

# Vibrating Probes:

## 200 Series

### Features

- No moving parts to wear out
- Strong stainless steel construction
- Tip sensitive not affected by wall cling
- Sharp blade prevents material build up
- No calibration or adjustments needed
- High temperature 150°C option
- Rigid tube and cable extension versions
- Ex ia versions for dust and gas applications

The Pulsarpoint 200 series is a range of vibrating level switches, for bulk solids applications. When solids material comes into contact with the vibrating probe, the frequency of oscillation changes. This is detected and a signal generated to provide a changing relay output.

May be used to signify a material level as being high, intermediate or low depending on configuration chosen.

The design of the sharp edged blade profile and the frequency of oscillation ensure that the probe is able to resist material build up, which may be associated with other tuning fork designs. This provides long trouble free operation.

### Application

Effective management of material storage and flow prevents overflows, empty vessels, clogged or blocked chutes or conveyors. Costly or dangerous spillage, material waste or unnecessary maintenance may therefore be avoided.

Typical applications may be found in the food, animal feed, pharmaceutical, chemical, plastics, quarrying, power generation, cement and other bulk solids material storage industries. It is suitable for most dry bulk solids from powder up to 20mm particle size.

Products include: flour, sugar, cellulose, coffee, sawdust, styrofoam, powdered milk, tea, ground glass, sand, grain, pellets and animal feed.

A normal process temperature of -20°C to +80°C may be monitored with the standard unit, whilst a higher temperature version the 212, allows a process temperature of 150°C to be handled.

### Pulsarpoint 210 - standard

The 210 is suitable for most granular products with a bulk density of 20g/litre or more. A relay output is standard. The electronics are mounted in a diecast aluminium housing. The process connection and probe are in stainless steel. An adjustable sensitivity setting allows easy adjustment to suit the material being monitored.



POINT 210

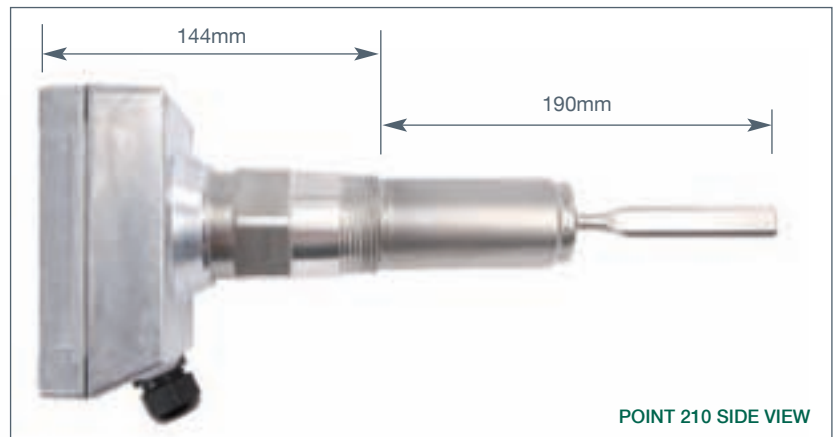

POINT 210 SIDE VIEW



THIN PROFILE BLADE PREVENTS BUILD UP



### Pulsarpoint 212 - high temperature unit

This 212 unit uses a separate electrical enclosure, with a 2m long high temperature cable, between the fork assembly and the separated electronics. Applications up to 150°C process are able to be handled.



POINT 212

### Pulsarpoint 214 - rigid tube extension

Where a longer insertion length is needed, then 214 can be provided this with its rigid welded tube construction. This is suitable for top mounting on a vessel or silo. Maximum insertion length is 2m.



POINT 214

### Pulsarpoint 215 - cable extension

The polyurethane sheathed steel reinforced cable allows insertion lengths up to 20m. These versions are typically used in bulk powder as high level switches leaving sufficient space not to overfill the silo. Cable length needs to be specified at the time of ordering.

**Pulsarpoint 210 – Ex ia**

**Pulsarpoint 214 – Ex ia**

**Pulsarpoint 215 – Ex ia**

These versions are all available with flammable atmosphere approval to the following:

**Gas:** ATEX II 1G Ex ia IIB T4.  
(Zone 0, 1 and 2)

**Dust:** ATEX 1D Ex ia D20 TX  
(Zone 20, 21 and 22)

See specification table for electrical supply and output signal of these Ex ia versions.



## Technical Specification: Pulsarpoint 200 Series

210 (SOLID):	
<b>Power Supply:</b>	20 to 250 V AC/DC, 3VA (Ex ia version 18 to 23, 7V DC provided by barrier unit)
<b>Output:</b>	1 volt free contact (SPDT) 8A @250Vac (Ex ia version 8 / 16mA depending on switching mode)
<b>Sensor:</b>	Stainless steel 1.4301 / AISI 304
<b>Housing:</b>	IP 66/67 Diecast aluminium
<b>Thread:</b>	1½ " conical DIN 2999 ( 1½ " BSP) or NPT
<b>Resonance frequency:</b>	290 HZ
<b>Temperature limits:</b>	Process -20°C to +80°C (212 sensor unit -20°C to +150°C), ambient 20°C to 60°C
<b>Application:</b>	Minimum material density: 20g/litre
<b>Maximum pressure in silo:</b>	10 bar
<b>Options:</b>	DPDT, 24V or 48Vac, 24Vdc; Extensions
PULSARPOINT 200 SERIES OPTIONS:	
<b>210:</b>	Standard length probe system
<b>212:</b>	High temperature 150°C standard length probe system with 2m separation
<b>214:</b>	Rigid tube extension up to 2m between probe and electronics
<b>215:</b>	Flexible cable extension up to 20m between probe and electronics

# Rotating Paddles:

## 300 Series

### Features

- Robust and high reliability switching
- High, demand and low level switching
- Low cost polypropylene versions
- High strength stainless steel
- Cable and rigid extension options
- High temperature +350°C option
- ATEX dust Ex ia Zone 20/21 option

The Pulsarpoint 300 series is a range of rotating paddle level switches, for level measurement and switching on bulk solids. The paddle's rotation is interrupted when material reaches the paddle, causing a clutch to disengage the motor. This in turn actuates a relay allowing an alarm signal to be switched. This may be used to signify a material level as being high, intermediate or low depending on configuration chosen.

### Application

Effective management of material storage and flow prevents overflows, empty vessels, clogged or blocked chutes or conveyors. Costly or dangerous spillage, material waste or unnecessary maintenance may be avoided.

Typical applications may be found in the food, animal feed, pharmaceutical, chemical, plastics, quarrying, power generation, cement and other industries employing bulk solids material storage or conveying.

Suitable products for monitoring include plaster, cement, chalk, lime, granules, wood chips, cereals, cocoa, sugar, animal feeds, washing powders or plastic powders and pellets.



### Pulsarpoint 300

The 300 utilises a polycarbonate housing, sealed to IP 66. The process connection is of the same material, with a polypropylene paddle.



### Pulsarpoint 310

The 310 has a diecast aluminium housing sealed to IP 66, with process connection in aluminium, or stainless steel. Various paddle materials, along with options on seals for aggressive media applications are available. The 310 switch is available for high application temps of up to 350°C. It is also available with ATEX dust approval for zone 20, 21 and 22.

### Options

Switches are available with solid or cable extension, allowing a wide range of alarm points to be catered for with materials to suit the application, as well as high temperature versions for applications up to 350°C, such as is required in electrostatic precipitator hopper level measurement.

## Technical Specification: Pulsarpoint 300 series

### TECHNICAL SPECIFICATION PULSARPOINT 300 and 310:

<b>Voltage: (5 versions):</b>	240, 110, 48, 24VAC 50/60HZ, 24V DC
<b>Installed load:</b>	3VA
<b>Switched output:</b>	Max. load 250V, 2A, AC: 300V, 2A, DC

### TECHNICAL SPECIFICATION PULSARPOINT 300:

<b>Housing:</b>	Polycarbonate IP66
<b>Cable entry:</b>	1 entry with M20 x 1.5. 2nd entry optional
<b>Process connection:</b>	1½" " DIN 228 (1½" BSP)
<b>Process connection material:</b>	Polycarbonate
<b>Shaft material:</b>	Stainless steel
<b>Paddle material:</b>	Polypropylene
<b>Bearing and seal:</b>	Slide bearing, shaft seal to DIN 3760
<b>Shaft speed:</b>	1 rpm with 1.3 second switching delay
<b>Minimum bulk density:</b>	Adjustable in 3 steps from 100g/litre
<b>Process temp and pressure:</b>	-20°C to +80°C and +0.8bar

### TECHNICAL SPECIFICATION PULSARPOINT 310 and ATEX EX IA OPTION:

<b>Housing:</b>	Aluminium die cast IP65
<b>Cable entry:</b>	1 entry with PG13.5 gland. 2nd entry optional
<b>Process connection:</b>	1½" " DIN 228 (1½" BSP) or optional flange
<b>Process connection material:</b>	Stainless steel, aluminium, galvanised
<b>Shaft material:</b>	Stainless steel
<b>Paddle material:</b>	Stainless steel or polypropylene
<b>Bearing and seal:</b>	Ball bearing, shaft seal to DIN 3760
<b>Shaft speed:</b>	1 rpm with 1.3 second switching delay
<b>Minimum bulk density:</b>	15g/litre
<b>Process temp and pressure:</b>	-20°C to +80°C and +0.8 bar
<b>Flammable atmosphere version:</b>	Dust: ATEX 1/2D Ex ia D20 (Zone 20, 21 and 22)
<b>High temperature option:</b>	+350°C (not Ex version)

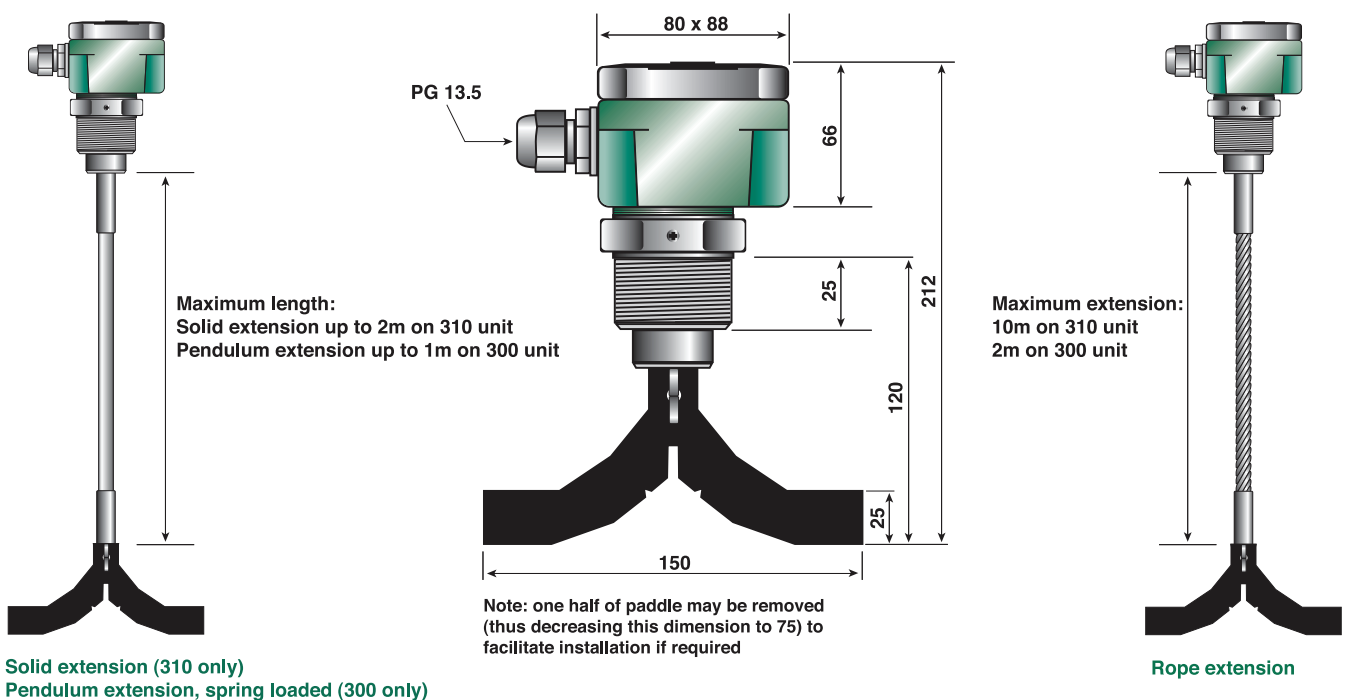

# Pressure Transducer:

## Pulsarbar 700 Pressure / Level transducers

### Features

- High stability
- ATEX EEx ia options available
- Choice of pressure connections
- Submersible and general purpose

Pulsarbar is a range of pressure and level transmitters that are perfect for demanding applications throughout industry and the utilities. They are exceptionally stable and combine advanced sensing technology with modern manufacturing methods to provide a superb pressure transducer with very long life. All Pulsarbar pressure transducers are submersible. The robust measurement cell provides good overrange protection and, with accuracy of at least 0.25% fs, you can specify Pulsarbar with confidence. Typical applications include borehole level measurement, sumps, tanks and basin depth.

### Pulsarbar 720 General Purpose Transducers

Pulsarbar 720 series feature a stable and accurate strain gauge sensor that provides accuracy of 0.25% together with a welded stainless steel back end for all demanding or submersible applications. Models are available for pressure ranges of vacuum to 400bar and offer a stability of 0.2% full scale per year (non-cumulative). Gauge, absolute and relative pressure versions are available, with a choice of millivolt, voltage and current outputs.



### Pulsarbar 750 Low Range Transducers

Pulsarbar 750 features a strong ceramic diaphragm with high over-pressure capability and very accurate capacitance technology that will detect minute pressure variations while withstanding large pressure spikes. Sensing ranges are available from 25mbar to 1 bar, with voltage or current output options. Sensing range is adjustable via a potentiometer to give a 3:1 turndown ratio from the capsule range.



### Pulsarbar 760 Transducers with turn-down

For applications where a wide range ability is required the Pulsarbar 760 provides an internal 5:1 turndown capability using a potentiometer. Gauge and absolute sensing ranges are available from 180mBar to 400bar. The Pulsarbar 760 features a sputtered sensing element for high stability with an accurate strain gauge sensor. The Pulsarbar 760 has a rugged stainless steel enclosure. Design life is 100 million full scale cycles.



## Technical Specification: PULSARbar 700 series

PULSARbar VERSION	PULSARbar 720	PULSARbar 750	PULSARbar 760
<b>INPUT</b>			
<b>Pressure range:</b>	Vacuum to 400bar	0-25mbar to 0-1bar	0.18 to 400bar
<b>Proof pressure:</b>	2 x full scale (FS) (1.5 x FS for 400bar)	2bar for range to 200mbar 4bar for range 201 to 350mbar 7bar for range 351mbar to 1bar	2 x full scale (FS)
<b>Burst pressure:</b>	>35 x FS (<=6bar) >20 x FS (>=60bar) >5 x FS (<=400bar)	3bar for 70mbar and below 4bar for 71 to 200mbar 6bar for 201 to 350mbar 10bar for 351mbar to 1bar	>35 x FS (<=6bar) >20 x FS (>=60bar) >5 x FS (<=400bar)
<b>Fatigue life:</b>	> 100 million FS cycles	10 million FS cycles	> 100 million FS cycles
<b>Supply voltage:</b>	24Vdc (7-35Vdc) 4-20mA output version	9-35Vdc 4-20mA version	8.5-40 Vdc 4-20mA only
<b>PERFORMANCE</b>			
<b>Long term drift:</b>	0.2% FS per year (non-cumulative)	0.25% FS per year	0.15% FS per year
<b>Accuracy:</b>	0.25% FS typical	0.2% span maximum	0.15% FS typical
<b>Thermal error:</b>	1.5% FS typical	2% span maximum	0.5%-1% FS typical
<b>Compensated temperatures:</b>	-20 to 80°C	-20 to 60°C	-20 - 80°C
<b>Operating temperatures:</b>	-20 - 50°C submersible version	-20 - 50°C submersible version	-20 - 50°C submersible version
<b>Zero/Span tolerances:</b>	1% of span	0.1% of span	0.1% of span
<b>Zero adjustment:</b>	approx 10% factory set	+/-10%	+/-10% (100% at factory)
<b>Span adjustment:</b>	approx 50% factory set	+/-10%	17 - 100% of span (potentiometer)
<b>MECHANICAL CONFIGURATION:</b>			
<b>Pressure port:</b>	Various	Various	Various
<b>Wetted parts:</b>	17-4 PH stainless steel	s/s to UNS 31803 Inconel 625, ceramic and nitrile	17-4 PH stainless steel
<b>Electrical connection:</b>	moulded cable submersible	moulded cable submersible	moulded cable submersible
<b>Enclosure:</b>	Submersible version IP68	Submersible version IP68	Submersible version IP68
<b>Approvals:</b>	CE	CE; ExII 1G; EExia IIB*	CE; ExII 1G;EExia II CT4*
<b>Weight:</b>	Approx 100g (cable 75g/m)	330g plus cable	250g plus cable
* ExII is optional extra			
<b>OUTPUT:</b>			
<b>Output:</b>	4-20mA (2 wire)	4-20mA (2 wire)	4-20mA (2 wire)
<b>Max loop resistance:</b>	(Vs-7) x 50 ohms	(Vs-9) x 50 ohms	(Vs-8.5) x 50 ohms
<b>Versions:</b>	Millivolt and voltage output versions also available	Voltage output version also available	Current output only

# Float Switches:

## 800 Series

### Features

- High quality, high reliability, low cost
- Up to 13 Amp current switching (specials available)
- Adjustable pumping range
- High quality cable entry seal to floats
- Pump up, pump down or SPDT operation
- Resistant to turbulence or rotation
- Mounting straps and cable weights choice
- Standard with 3m or 10m leads, (longer lengths are available on request)
- Single pole double throw (SPDT) Can carry out both the low or high level alarm functions. Has 3 core cable.

The Pulsarpoint 800 range of liquid level float switches and accessories offer the user a wide selection of high integrity devices, designed for very reliable operation when controlling the level of non-potable water and sewage. Versions are available to provide alarm control and pump control. The units have all been designed for maximum durability and dependability, and are manufactured to the highest standards.

### Description

Mechanically activated designs are available. With units capable of switching operating currents from 5 to 13 Amps, pump up or pump down.

The 800 series pump control switches have a wide angle operation to enable user adjustable pumping ranges from one pump switch.

The 800 series alarm control switches have narrow angle operation to provide precise switch on and off points to activate pump control panels and alarms.

The floats are manufactured from high impact and corrosion resistant PVC or polypropylene and are suitable for liquid temperatures up to 60°C.

A specially designed seal bonds the cable into the float, preventing water ingress, whilst allowing flexibility and ensuring reliable operation.

Pulsarpoint 800 series float switches have typical working life of over ½ million operations.

Pipe clamp and cable weighted versions are available, as well as Single Pole Double Throw outputs for pump up or pump down operations from one switch.

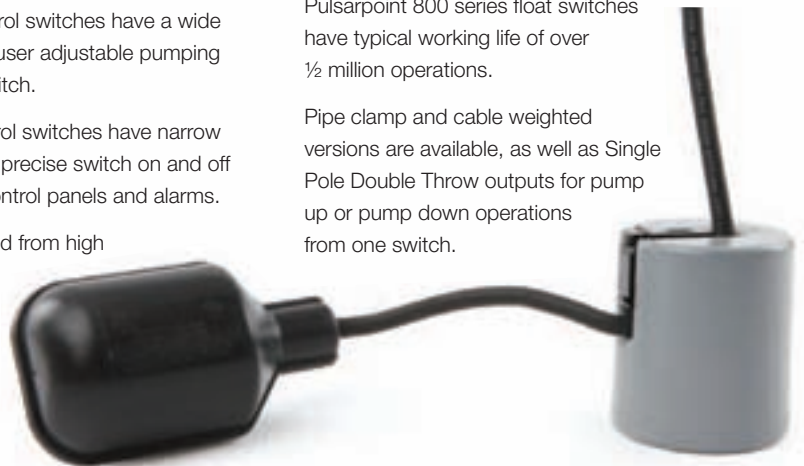

### 800-20 Pump Master – Pump Switch

A versatile, mechanically activated wide angle pump switch, not sensitive to turbulence. Controls pump control panels or control pumps directly up to 1.35kW at 115V AC and 2.59kW at 230V AC. Maximum continuous current 13 Amps, maximum starting current 85 Amps. Pump up and pump down or SPDT versions. Available with cable weight option.

The float is 7.73cm dia x 9cm and is manufactured from PVC. Adjustable pumping range from 18cm to 91cm.

### 800-50 Micro Master – Pump Switch

A low cost mechanically activated pump switch designed for use in turbulent conditions. Controls pumps up to 10 Amps at 115V AC, 8 Amps at 230V AC. Pump up, pump down or SPDT versions.

The float is 7cm dia x 12.3cm and is manufactured from high impact resistant polypropylene.

### 800-70 Signal Master – Control Switch

A high performance, mechanically activated narrow angle control switch designed to accurately activate pump control panels and alarms. Switches currents of up to 5 Amps AC.

Switch operating range typically  $\pm 4$ cm from horizontal. Pump up, pump down or SPDT versions are all available with pipe clamp or cable weight options. The float is 7.2cm dia x 8.7cm and is manufactured from high impact resistant polypropylene housing.

This narrow-angle sensing device is used to accurately monitor liquid levels in:

- Potable water
- Water
- Sewage applications

The Pulsar Signal Master SPDT can be wired to work in either normally open or normally closed applications. It is not sensitive to rotation.



### Normally Open Model (high level)

The control switch turns on (closes) when the float tips slightly above horizontal signalling a high level, and turns off (opens) when the float drops slightly below horizontal.

### Normally Closed Model (low level)

The control switch turns on (closes) when the float tips slightly below horizontal signalling a low level, and turns off (opens) when the float tips slightly above horizontal.

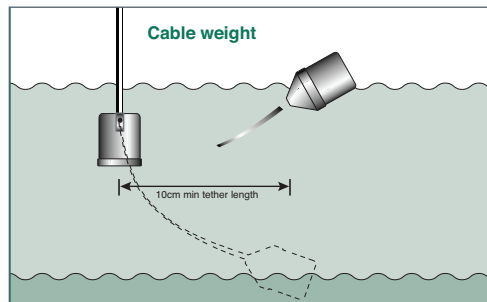
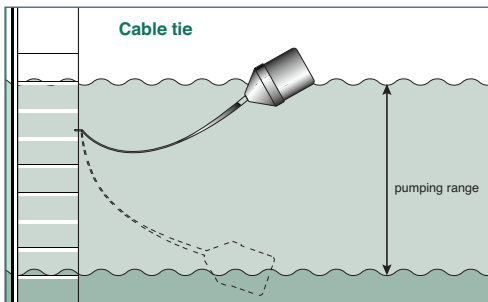

## Technical Specification: Pulsarpoint 800 Series - Float Switches

### 800 -20 PUMP MASTER – PUMP SWITCH:



A most versatile, mechanically activated wide angle pump switch, not sensitive to turbulence. Controls pump control panels or control pumps directly up to 1.35kW at 115V AC and 2.59kW at 230V AC. Maximum continuous current 13 Amps, maximum starting current 85 Amps. Pump up and pump down or SPDT versions. Available with cable weight option. The float is 7.75cm dia x 9cm and is manufactured from PVC. Adjustable pumping range from 18cm to 91cm.

### 800-50 MICRO MASTER – PUMP SWITCH:



A low cost mechanically activated pump switch designed for use in turbulent conditions. Controls pumps up to 10 Amps at 115V AC, 8 Amps at 230V AC. Pump up, pump down or SPDT versions. The float is 7cm dia x 12.3cm and is manufactured from high impact resistant polypropylene. Adjustable pumping range from 20cm to 91cm.

### 800-60 SENSOR FLOAT – CONTROL SWITCH:



A mercury activated, narrow angle control switch designed to accurately activate pump control panels and alarms. There is a smaller version for operation in confined spaces. Switches currents of up to 5 Amps AC. Switch operating range typically  $\pm 1$ cm from horizontal. Pump up, pump down or SPDT versions are available with the pipe clamp, integral weight (not SPDT) or cable options. The float is 8.6cm dia x 11.6cm and is manufactured from PVC.

### 800-70 SIGNAL MASTER – CONTROL SWITCH:



A low cost, mechanically activated narrow angle control switch designed to accurately activate pump control panels and alarms. Switches currents of up to 5 Amps AC. Switch operating range typically  $\pm 4$ cm from horizontal. Pump up, pump down or SPDT versions are all available with pipe clamp or cable weight options. The float is 7.2cm dia x 8.7cm and is manufactured from high impact resistant polypropylene housing.

# Pulsar Guard 2010:

## Non-invasive solids flow monitor

### Features

- Non invasive and maintenance free
- Simple bolt on installation
- Low cost
- No moving parts and vibration resistant
- IP 68 Stainless Steel housing
- Highly reliable in low or high temperatures
- ATEX Flammable atmosphere approved '2011' option

The Pulsar Guard 2010 sensor detects structure borne acoustic signals caused by the movement of material. This movement causes impacts and frictional contact with a containing face, for example the inside of a pipe. The sensor is fastened to the outside of the structure, and its high frequency detection picks up these signals, which are often undetectable to the human ear. The high frequency detection allows use in environments where there is a high degree of machinery or process noise, without interference. Pulsar Guard's non-invasive nature allows easy fit to most pipes, chutes or feed mechanisms without stopping the process.

### The Technology

The 2010 series of process protection units use patented state of art soundwave technology to detect changes in structure borne acoustic emissions from equipment and materials in motion. The sensor listens to noise caused by impacts, and friction within structures, on a wide frequency band width of 100 to 600kHz, making it sensitive to the slightest changes in process conditions, but also immune to audible noise or vibration caused by plant machinery.

Instant reaction to flow changes provides protection to plant operation from abnormal flow conditions in pipes, supply lines, chutes and feed machines. Fine powder in flight, in minute quantities can generate a large acoustic signal enabling flow or no flow alarms.

### Easy To Use

The 2010 sensor series is designed with the operator in mind. Powered with 23 to 30 V DC the sensor provides a 0 to 10 volt output, this signal may be fed directly to a PLC, or the optional control unit 2020.

### Simple Installation

As the sensor is completely non-invasive there is no need to shut down the process for installation. Installation takes minutes, and the compact design means that it can be fitted in the tightest of positions or environments.

### Typical Applications

- Burst filter bag detection
- Detects impending blockages
- Detects flow and no flow of solids
- Detects pump cavitation
- Valve leakage detection
- Detects Bridging or Rat-holing in silos
- Material flow/route verification
- Bearing failure

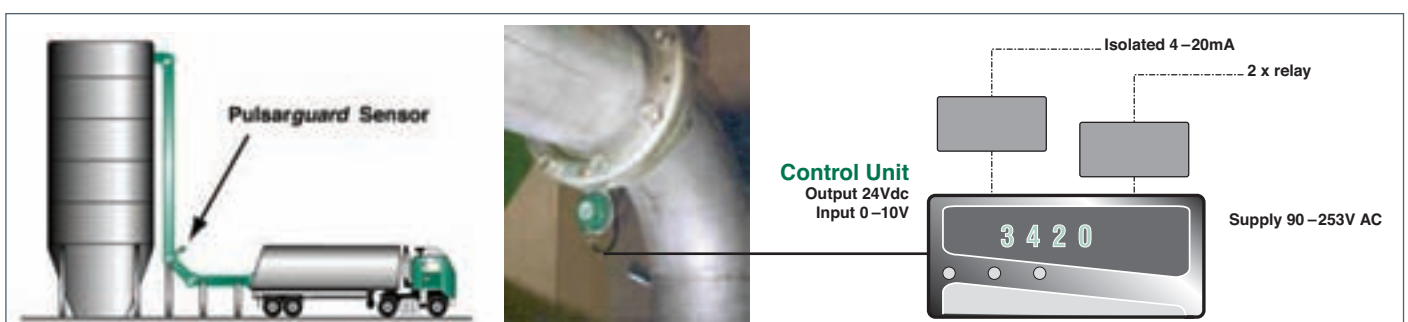



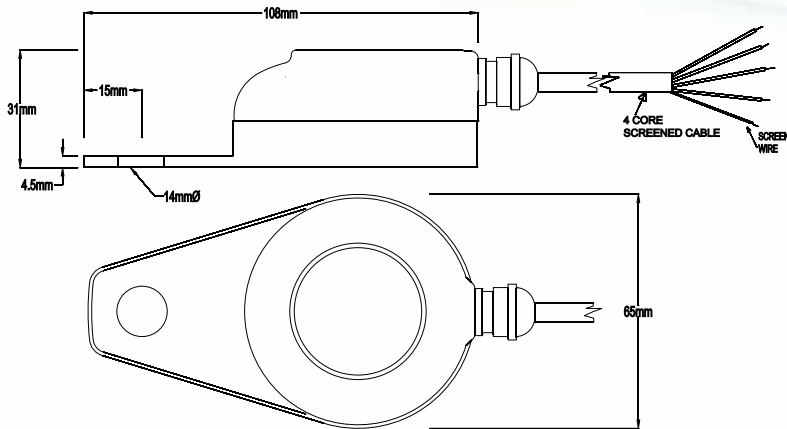

Flammable atmosphere versions are available.

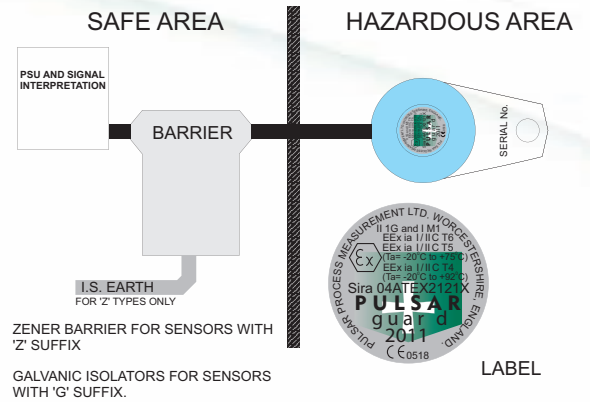

The standard sensor 2010 has a temperature range of -40°C to +85°C.

A higher temperature sensor version the 2015 unit which can operate up to +125°C.

BARRIER PARAMETERS	SENSOR LABELLING
POWER SUPPLY U <sub>o</sub> =28 V I <sub>o</sub> = 93.3 mA P <sub>o</sub> = 0.635 W	ZONE 0: CERT No. Sira 04ATEX2121X EEx ia I/IIC T6 (Tamb= -20°C to +40°C) EEx ia I/IIC T5 (Tamb= -20°C to +75°C) EEx ia I/IIC T4 (Tamb= -20°C to +92°C)
SIGNAL SUPPLY U <sub>o</sub> =18 V I <sub>o</sub> =15.3 mA P <sub>o</sub> =0.07W	



2010 SENSORS FITTED TO ANIMAL FEED CHUTES



## Technical Specification: 2010, 2015, 2011Z and 2011G Sensor

<b>Detection frequency:</b>	100 to 600 kHz
<b>Power supply required:</b>	23 to 30 V DC (except 2011Z = 24V to 26 V DC)
<b>Analogue output:</b>	0 to 10 V DC
<b>Cable:</b>	4m of 4 core shielded 24 AWG
<b>Operating Temperatures:</b>	Standard version (2010 unit): -40° to +85°C High temperature version (2015 unit): -40° to +125°C
<b>Ingress protection:</b>	IP 68 (NEMA 4)
<b>Sensor mounting:</b>	Tab with 14mm hole
<b>Construction:</b>	Cap and base housing in 316 stainless steel
<b>Weight:</b>	640 grams (includes cable)
<b>Size:</b>	120mm long
<b>Electrical connection:</b>	4 core screened cable

### (I.S.) 2011Z

Suitable for use with Zener barriers only. This system requires connection to an intrinsically safe earth. Identified by "Z" stamped on mounting tab. Approval to EEx ia IIC T6 (+40°C), or EEx ia IIC T4 (+92°C).

### (I.S.) 2011G

Suitable for use with Galvanically isolating barriers only. This system does not require connection to an intrinsically safe earth. Identified by "G" stamped on mounting tab. Approvals as above.

## 2020 Control unit

Pulsarguard 2020 panel mounted optional controller. Has LED display and AC supply (DC option) excitation for the 2010 sensor. Optional pods of functions (max 2 pods per controller)

**Pod 02-** Dual alarm relay pod, two mains rated user definable relay outputs.

**Pod 03-** Isolated 4 – 20mA retransmission pod.

**Pod 05-** Modbus RTU serial comms pod, 4 wire or 2 wire half duplex.

# Application Data Sheet:

Page  of

**Company:**

**Address:**

**Date:**

**Contact:**

**Phone:**

**Fax:**

**Email:**

## If Solids

**Particle size:**

**Bulk density:**

**Temperature:** Min  Max  °c

**Dust in air:** None  Low  High

**Angle of repose:** Flat  Low  High

**Bridging:** Yes  No

**Rat holing:** Yes  No

## If Liquids or Slurries

**Build-up on walls:** Yes  No

**Temperature:** Min  Max  °c

**Liquid surface:** Still  Waves  Turbulent

**Foam:** Yes  No  If yes, what is av height (m)

**Vapour:** Yes  No

**Condensation:** Yes  No

**Carbon Dioxide, Methane or Hydrocarbons:** Yes  No

## Application Information

**Material:**   **Quantity of Instruments:**

**Application:** Continuous Level  Point Level  OCM Flow

**Type of Primary Device:**

**Pump Control, how many pumps:**  **Relays required:** Yes  No  If yes, how many:

**Range to be measured:**  m **Diameter:**  m (see sketch below)

**Is the area General Purpose:**  **Hazardous:**  **Classification Requirements:**

**Transducer mounting:** 1.5" BSP  2" BSP  Flange: 2"  3"  4"  6"  8"

50 DIN  80 DIN  100 DIN  150 DIN  **Power Supply:** AC 115-230  DC  DC Loop Powered

**Output required:** 1 x 4-20mA  2 x 4-20mA  Modbus RTU  Profibus DP: Vs0  or Vs1  Ethernet

Sketch application and provide any comments:

# Notes:



011  
**sira**  
Registered Company  
Cert No. 072570



011  
**sira**  
Registered Company  
Cert No.950136

Pulsar Process Measurement Limited operates a policy of constant development and improvement and reserves the right to amend technical details as necessary

Pulsar® Process  
Measurement Ltd.

Cardinal Building  
Enigma Commercial Centre  
Sandy's Road  
Malvern  
Worcestershire  
WR14 1JJ  
England

Tel: +44 (0) 1684 891 371  
Fax: +44 (0) 1684 575 985  
Email: [info@pulsar-pm.com](mailto:info@pulsar-pm.com)

[www.pulsar-pm.com](http://www.pulsar-pm.com)

Pulsar® Process  
Measurement Inc.

P.O. Box 5177  
4565 Commercial Drive  
Suite 105  
Niceville  
FL 32578  
USA

Tel: +1 850 279 4882  
Fax: + 1 850 279 4886  
Email: [info.usa@pulsar-pm.com](mailto:info.usa@pulsar-pm.com)