



**MegaFab™**

INSTRUCTIONS  
AND REPAIR PARTS  
MANUAL FOR

**PIRANHA**

IRONWORKER  
MODEL NUMBER  
P-90

Publication: April, 2013

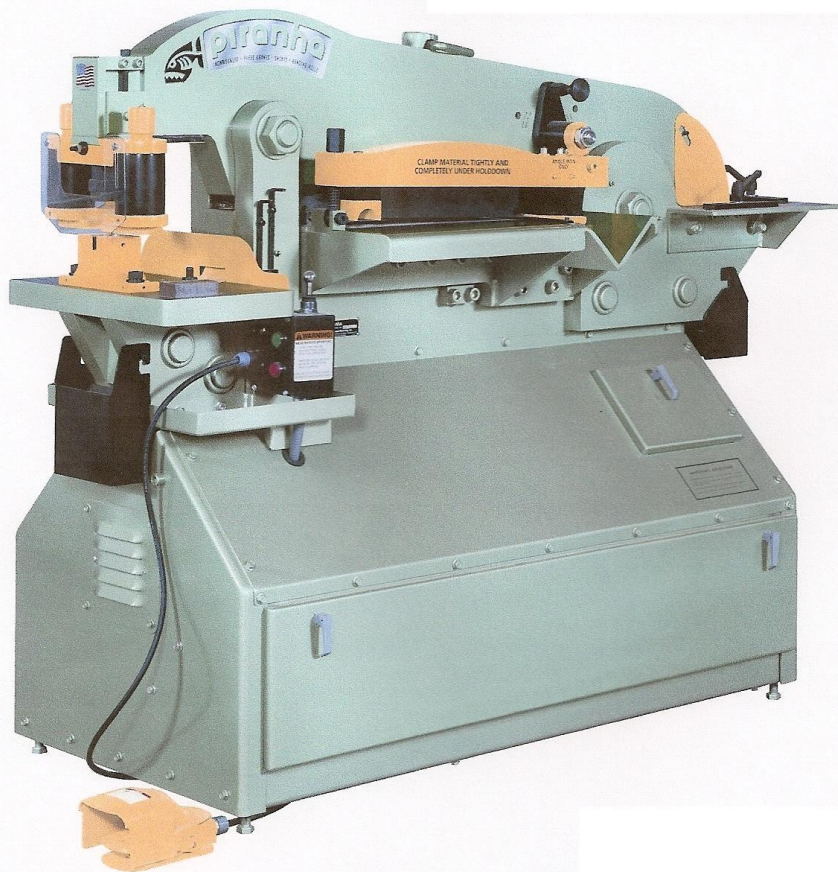

For Serial Numbers  
P90-3001 to Current  
Models

[www.megafab.com](http://www.megafab.com)  
800-338-5471

Be sure to register your model  
and serial number to receive  
Piranha Service and Product  
Updates.

# Piranha Optional Tooling and Attachments

## Enhance your Ironworker's Versatility

### Oversize Punch Attachments

- Expand your punching capacity up to 5"

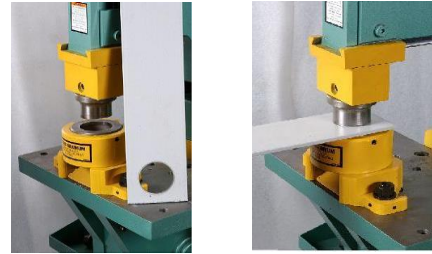

### Quickset Gauging Table

- Allows you to quickly set-up your punch end for multiple holes.
- Includes an angle gauge bar to index off the heel of your angle and a plate gauge bar, which indexes off the end of your plate.
- Extensions are available in left and right hand styles in 5' and 10' lengths.

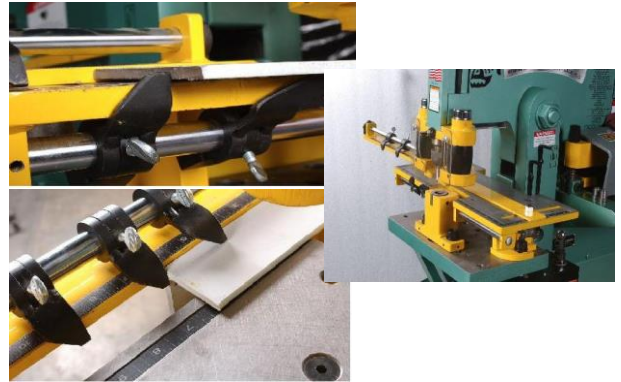

### Backgauge

- Allows you to quickly set-up your machine to repeat your shearing length by adding a mechanical backstop.
- Backstop can be positioned in either the angle, flat bar, or round bar section of the machine.
- Available in lengths of 3', 6', 9', or 12'.
- An electronic version is also available, which cycles the machine automatically when material makes contact with the backgauge probe.



### Pipe Notching Attachment

- Allows you to single notch Schedule 40 Pipe.
- A must have for handrail jobs.
- Attaches to the punch end of the machine.
- Notching dies available for 3/4", 1", 1-1/4", 1-1/2", and 2" Schedule 40 Pipe.
- 

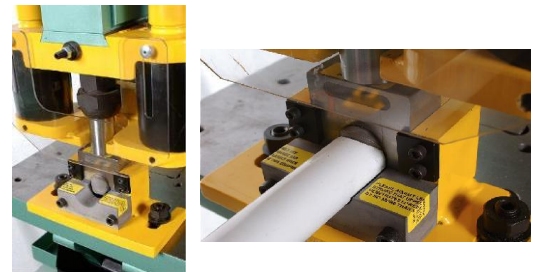

### Oversize Bending Attachments

- Expand your bending capacity to 24" on most models.
- Includes a 4-way die block for different thicknesses of material.



\*\*\* Additional Options Shown on Inside of Back Cover\*\*\*

INSTRUCTIONS  
AND  
REPAIR PARTS MANUAL  
FOR  
**PIRANHA**  
IRONWORKER

MODEL NUMBER P-90

Publication: April, 2013

P.O. Box 1206  
Rockford, IL 61105  
PH: 800-338-5471  
FAX: 815-964-0831  
[www.megafab.com](http://www.megafab.com)



## TABLE OF CONTENTS

Refer to second section of this manual for information on repair parts breakdown and ordering repair parts.

	<b>Page No.</b>
FORWARD .....	4
WARRANTY .....	4
INTRODUCTION .....	5
SAFETY PRECAUTIONS .....	6
MACHINE SPECIFICATIONS .....	7
FUNCTIONAL DIAGRAM .....	8
DIMENSIONAL DATA.....	9
STANDARDS COMPLIANCE .....	10
INSTALLATION .....	11
OPERATING INSTRUCTIONS.....	13
LUBRICATION.....	20
MAINTENANCE.....	21
TROUBLESHOOTING.....	22
CALCULATING PUNCHING FORCE .....	26
PUNCH & DIE CLEARANCE CHART.....	27
TOOL LIST .....	27
ORDERING INSTRUCTIONS.....	RP-1
REPAIR PARTS ILLUSTRATIONS.....	RP-2
REPAIR PARTS ILLUSTRATION INDEX.....	RP-3
SERVICE RECORD CHART .....	RP-23

## **FOREWORD**

This manual has been prepared for those persons who will operate and maintain the Piranha Ironworker. It is important that all persons responsible for the care and operation of this equipment read and understand the information presented in this publication.

The illustrations and instructions on the following pages were the most recent available at the time of publication and selection of this material was made based on a standard machine arrangement. Differences between the machine you received and the views contained in this manual are the result of design improvement and / or the addition of optional accessories specified on your order.

## **WARRANTY**

Mega Manufacturing will replace (F.O.B. our factory), or refund the purchase price for any goods which are defective in materials and workmanship within 12 months of date of purchase. The buyer must return the warranty registration card within thirty-(30) days of the purchase date, and at the seller's option, return the defective materials freight and delivery prepaid to the seller, which shall be the buyer's sole remedy for defective materials. Seller shall not be liable to purchaser or any other person for consequential or incidental damages. Hydraulic and electrical components are subject to their respective manufacturer's warranties. This warranty does not apply to machines and / or components, which have been altered in any way, or subjected to abusive or abnormal use, inadequate maintenance, and lubrication, or to use beyond seller's recommended capacities and specifications. Seller shall not be liable under any circumstances for labor costs expended on such goods or consequential damages. Seller shall not be liable to purchaser or any other person for loss or damage directly or indirectly arising from the use of the goods, or from any other cause. No employee, agent, officer, or seller is authorized to make oral representations or warranty of fitness or to waive any of the foregoing terms of sale and none shall be binding on the seller.

## INTRODUCTION

The Piranha Ironworker is a compact hydraulically powered machine that shears, punches, bends, notches, and copes, all in a low silhouette, efficiently designed unit, resulting in minimal floor space requirements. The integral lifting lug provides instant portability and the unit arrives fully assembled, requiring only the addition of hydraulic oil and electrical power to become fully operational. A quick-change mounting assembly, utilizing a split dovetail, allows setup from punching to bending in less than one minute. The large platen has seventeen 5/8-11 tapped holes giving a wide base for increased flexibility of attachment sizes. The shearing operation features an adjustable automatic hold-down allowing the operator to clamp the work piece with a slight initial adjustment. All workstations are located approximately 44" off the floor for ease of operation.

The first part of this manual provides operations and maintenance instructions, including a section on troubleshooting various problems that may occur. The second part of this manual provides repair parts information and a complete parts list with their respective part numbers.

Proper understanding and application of the information and procedures given in this manual will aid in establishing a preventative maintenance program and, provide assistance for correcting malfunctions that may occur in the machine. The repair parts list provides information for parts procurement as well as assembly breakdowns to aid in disassembly and re-assembly for repair part installation.

## SAFETY PRECAUTIONS

The operator of this machine should view the operational video provided with the machine, and thoroughly understand this manual before starting any operation.

This machine was designed for use by a single operator only.

Wear eye protection at all times.

Use the proper voltage outlet for your machine.

Make sure that all guards and cover shields are down before starting machine.

**CAUTION:** *Do not remove guards.*

Keep hands off working tables and out of the path of moving parts during operation. Remove all material from the tables except for the work piece.

Remove all tooling from the punch end before starting shearing or coping operations.

Make sure that all tooling is properly held in position before starting any operation.

The area around the machine should be well lighted, dry, and as free from obstructions as possible.

All maintenance and repair work should be performed by a person familiar with this publication.

At the end of the working day, the operator should turn the power off to the machine.

Adjust limit switches when punching or bending to allow 1/4" maximum clearance between bottom of the stripper foot or bending punch and the top of the material. Contact the factory for limit switch adjustments on special tooling.

Turn selector switch to the "OFF" position when changing tooling or performing maintenance work. (Reference Page 12, Figure "B").

## MACHINE SPECIFICATIONS

<b>HYDRAULIC SYSTEM</b>	
Drive Motor	10 HP 230 / 460 Volt 3 Phase
Hydraulic Tank Capacity	25 Gallons
Hydraulic Oil	AW-32 or Equivalent ISO Grade 32
	Consult your local distributor for a cross reference.
<b>WORKING SURFACE</b>	
Platen	12" x 21"
Coping	18-1/2" x 18-1/2"
<b>CAPACITIES</b>	
Punch	Maximum 1-1/8" Thru 1" thick material or 90 Tons
Bending	Maximum 90 Tons
Punch End	Maximum 90 Tons
Bar	2" Round or 1-3/8" Square
Plate	3/4" x 12" or 1/2" x 18" with optional knives
Angle	5" x 5" x 1/2" with 4 Radius Knife
Coper-Notcher	3-1/2" x 5" x 3/8"
<b>WEIGHT</b>	
Shipping Weight	4,250 Pounds



# FUNCTIONAL DIAGRAM

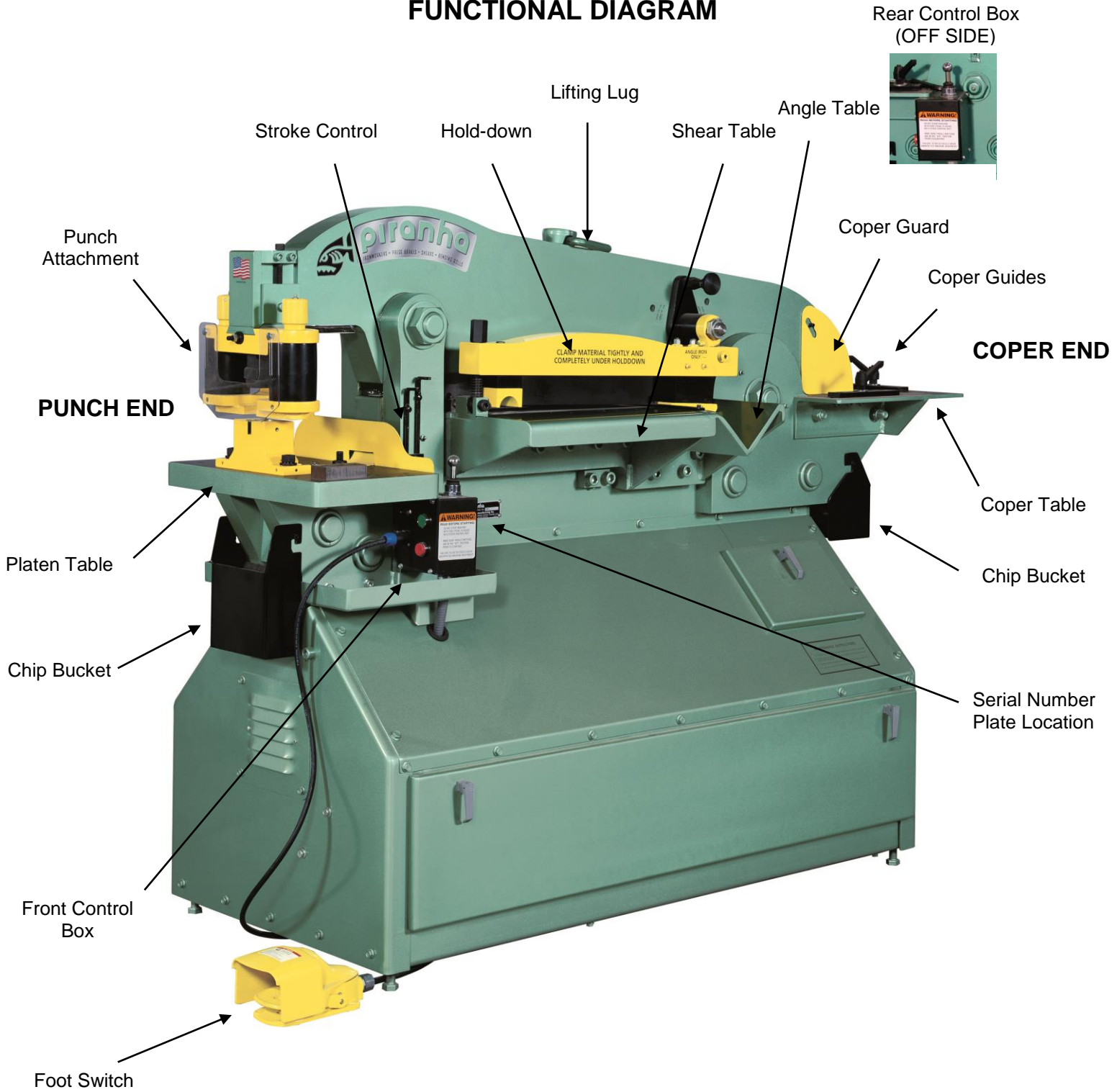

## DIMENSIONAL DATA

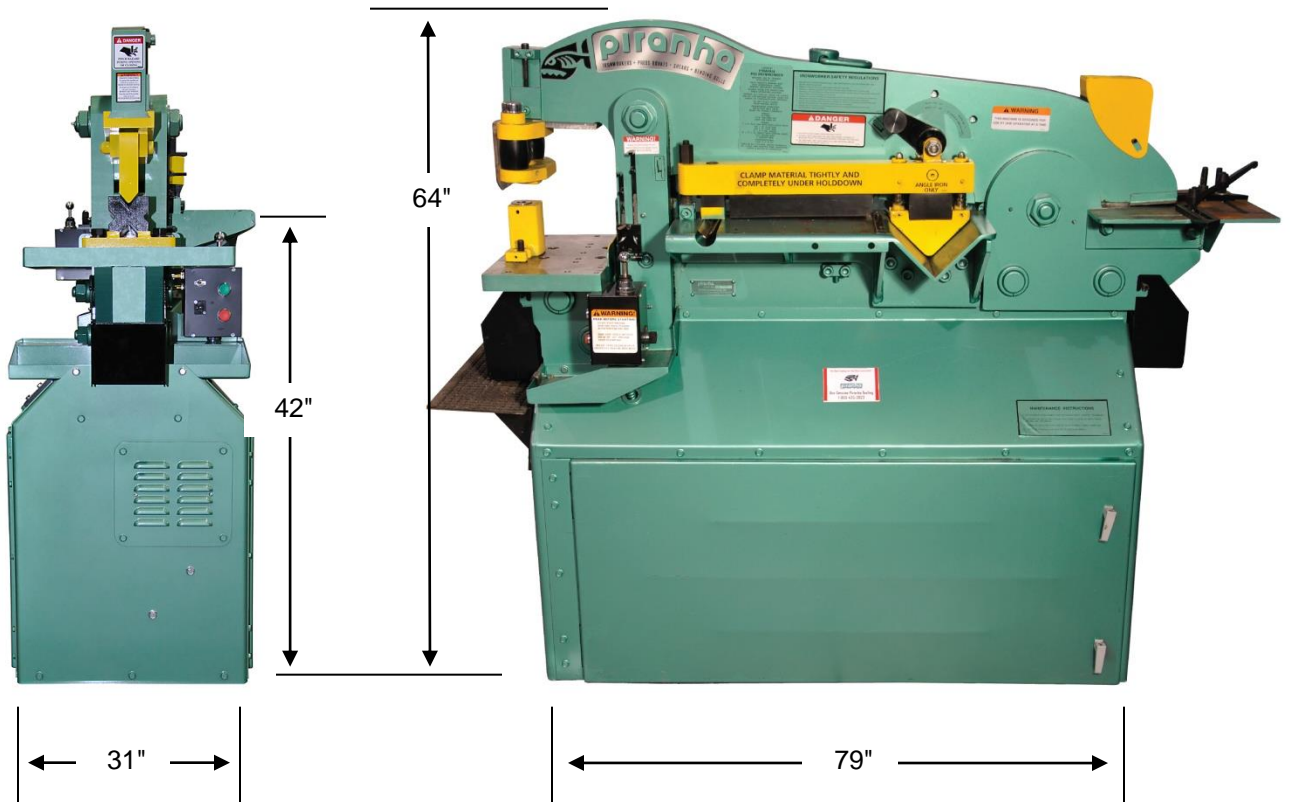

## **Standards Compliance**

### **Electrical System Design/Manufacture:**

The machines manufactured in Rockford, Illinois, USA are furnished with electrical / electronic products that are UL (Underwriter's Laboratory) approved. These components have the UL numbers printed or stamped on them and can be easily traced to the point of manufacture. In addition, all of the machines meet the current "Ontario Hydro" electrical code for proper manufacture of the electrical circuits.

### **Hydraulic System Design/Manufacture:**

Hydraulic components used in Piranha machines are approved by NFPA (National Fluid Power Association), and those approval numbers can be traced through the manufacturer's part numbers.

### **ANSI/OSHA Compliance:**

Mega Manufacturing meets the current ANSI construction standards for manufacturing of ironworkers, press brakes, and shears:

**ANSI B11.5 - Ironworkers, Construction, Care, and Use**

**ANSI B11.3 - Power press brakes, Construction, Care, and Use**

**ANSI B11.4 - Shears, Construction, Care, and Use**

The ANSI B11 standards were developed to establish levels of responsibility for manufacturing safe products, and for installing, training, and using these products. The levels of responsibility are fairly evenly distributed between the manufacturer, the owner/end-user of the equipment, and the operator. Specific guarding requirements are, in general, assigned to the owner/end-user of the equipment.

With specific reference to Ironworkers, OSHA (Occupational Safety and Health Administration) made a ruling on March 4, 1991 - under their standard number 1910.212, specific to the OSHA Machine Guarding Standard 29 CFR 1910.212(a)(1). This ruling is stated verbatim below:

"If an employer provides an iron worker machine (at his or her workplace), which is manufactured in compliance with the safety requirements specified in ANSI B 11.5-1988, and the guarding is maintained as required; then that employer meets OSHA's machine guarding requirements for that machine."

Please understand that this ruling places the primary burden of responsibility for maintenance of guarding on the owner/end-user of the equipment. Inherent in this requirement is the responsibility of the owners/end-users of the equipment to develop and maintain guarding specific to their application for the equipment. These ANSI safety requirements may be acquired from:

**American National Standard Institute 1430 Broadway  
New York, New York 10018 Telephone (212) 354-3300**

# INSTALLATION

## Location

For the best overall performance, install the Piranha in a location that is clean and well lighted. Provide sufficient space in all directions to allow for the material lengths of the work pieces to be processed by the Piranha.

## Foundation

To maintain the accurate alignment built into the Piranha, and to prevent undue stress on the moving parts under a load, the Piranha should be placed on a stable base or floor adequately constructed to withstand the unit weight. **NOTE: Use the leveling bolts provided with the machine.**

## Wiring

The Piranha is shipped totally wired through the electrical enclosure box. It has been left to the owner's discretion whether to wire direct to an electrical disconnect, or to install a cord and plug for mobility of the Piranha.

**CAUTION:** Compare machine wiring to input voltage *prior* to connecting power. Only connect the specified voltage to the machine.

## Lifting

The lifting lug on the Piranha is an integral part of the machine. Use a device with adequate lifting capacity to handle the Piranha.

**CAUTION:** The unit is exceptionally **top heavy!** Lifting from the underside of the machine may cause damage to the cabinet structure.

## Assembly

The Piranha is pre-assembled at the factory. The only requirements are the addition of hydraulic oil and electrical power.

**FIGURE "A"**



**Front Cover**  
Front and Rear  
Control Boxes

**FIGURE "B"**



**Rear Cover**  
Front Control  
Box Only

**NOTE:** Turn selector switch to OFF position when performing maintenance or changing tooling.

Selector Switch  
Front – OFF - Rear

**FIGURE "E"**

View Control Box  
Locations

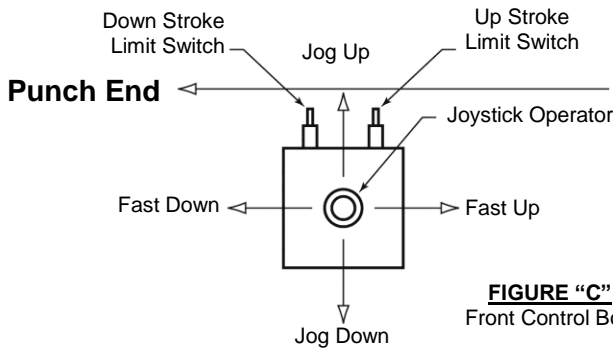

**FIGURE "C"**  
Front Control Box

**FIGURE "D"**

Rear Control Box

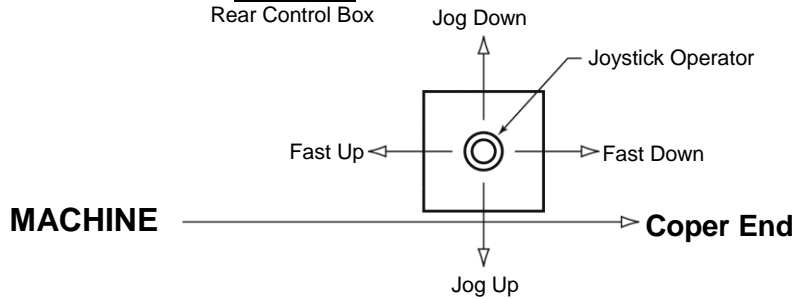

**Note:** Joystick Center Position is Neutral

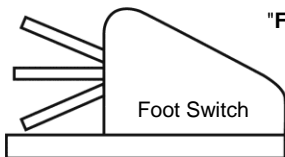

Foot Switch Lever Positions  
1) Beam Moves Up  
2) Beam is Stopped  
3) Beam Moves Down

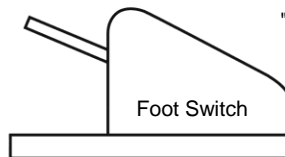

Foot Switch Lever  
Full Up Position  
Beam Elevates  
To Limit Setting

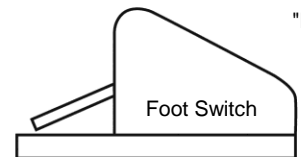

Foot Switch Lever  
Depressed Past Center  
Beam Moves Down  
To Limit Setting

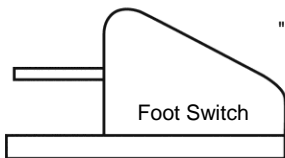

Foot Switch Lever  
Neutral Position  
Beam Travel  
Is Halted

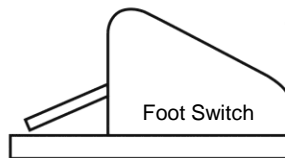

Foot Switch Lever  
Depressed Past Center  
Beam Moves Down  
To Limit Setting

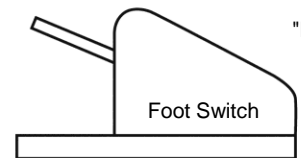

Foot Switch Lever  
Full Up Position  
Beam Elevates  
To Limit Setting

## **OPERATING INSTRUCTIONS**

(refer to drawings on page 12)

The Piranha Ironworker comes pre-assembled and pre-wired, requiring only the addition of hydraulic fluid in the reservoir to the mark on the fill cap dipstick and a power source from a disconnect to the electrical enclosure box located inside the cabinet.

The unit can be started and stopped by the push button operators located on the front cover of the control boxes on each end of the unit. (Reference Page 12, Figure "A"). For the Control Box locations, reference Page 12, Figure "E".

The electrical controls have a selector switch to determine which control box controls the unit. This safety feature is located on the rear cover of the front control box only, (reference Figure "B"). The legend plate on the selector switch is printed "Front-Off-Rear". "Front" allows electrical control to the Front Box only. "Off" disconnects electrical control to both control boxes. "Rear" allows electrical control to the Rear Box only. The selector switch should be in the "OFF" position when the machine is not being used, such as, changing tooling, maintenance work, etc. The machine can only be started from the control box selected via the selector switch. It can be stopped using either "stop" button.

### **Joystick Operation**

The ironworker is hand controlled by a five-position momentary joystick operator. When the joystick is released from any of the four positions, it will return to the neutral (center) position stopping machine movement instantly. The joysticks are located on top of the control box at each end of the machine (reference Figure "E").

The four controlling positions of the joystick are:

1. Fast Down (pulling the handle forward).
2. Fast Up (pushing the handle away).
3. Jog Down (pushing the handle to the right).
4. Jog Up (pushing the handle to the left). Reference: Figures "C" and "D".

All directions in Figures "C" and "D" are determined by standing at either end and facing the machine. The jog speed in both positions is a slow speed for alignment of center punch marks and scribe lines for shearing. The fast cycle should be used for the work cycle.

## Footswitch Operation

The ironworker can also be controlled by a footswitch (reference Figure "F"). The footswitch is used by plugging the 4-pole twist lock cap into the 4-pole twist lock receptacle located in the front cover of either control box (reference Figure "A"), and switching the toggle switch (reference Figure "A") from the "OFF" position to the "ON" position.

The footswitch is a three-(3) position switch allowing hands-free operation.

- By fully depressing the footswitch lever, machine movement is downward to limit setting (reference Figure F2).
- By allowing the footswitch lever to elevate to the center position, machine movement stops (reference Figure F3).
- Completion of downward cycle is accomplished by depressing footswitch lever again. Machine movement is down until limit setting is met (reference Figure F4).
- Removing foot pressure from the switch entirely allows machine movement upward to limit setting, completing upstroke cycle (reference Figure F5).

The footswitch is used in conjunction with the upstroke and down stroke limit switches located on the machine side off the front control box only (reference Figure "C").

- The front limit switch (closest to the punch end and the lower switch of the two switches) controls the down stroke limit.
- The back switch (furthest from the punch end and the higher of the two switches) controls the upstroke limit.
- The limit switches are activated by the limit switch arms: Item Number 60, shown on Page Number RP-3. To set the stroke using the limit switch arms, use the following procedure:
  - 1) Plug in footswitch.
  - 2) Turn toggle switch to "ON" position.
  - 3) Loosen thumbscrew on down stroke limit-switch arm.
  - 4) Fully depress footswitch lever allowing beam to move downward.
  - 5) Slide limit switch arm until contact with the down stroke switch stops beam movement at the desired lower limit.
  - 6) Tighten thumbscrew to hold limit switch arm firmly in place.
  - 7) Loosen thumbscrew on upstroke limit-switch arm.

- 8) Allow footswitch lever to elevate allowing beam to rise.
- 9) Slide limit switch arm until contact with the upstroke switch stops beam movement at the desired upper limit.
- 10) Tighten thumbscrew to hold limit switch arm firmly in place.

**NOTE:** When punching or using the bending attachment, set upper and lower limits to allow for 1/4" maximum clearance between the bottom of the punch and the top of the work material. The setting will change when the work material thickness changes.

**NOTE:** The down stroke limit switch on the punch end controls the upstroke limit on the coper end. The upstroke limit is the only switch controlled from the rear control box footswitch control. The operator controls the downstroke limit by allowing the footswitch lever to fully elevate after the upper coper knife passes through the material.



## STRIPPER ATTACHMENT ALIGNMENT

The alignment of the stripper should be accomplished in the following manner. (Reference Pages RP-3 and RP-8).

1. Slide the punch stripper assembly on the dovetail-mounting shoe.
2. Tighten the locking shoe by turning the cap screw clockwise (requires 3/8" Allen wrench). This locks the stripper assembly firmly in place.
3. Remove the coupling nut from the punch stem using the coupling wrench.
4. Insert the punch in the coupling nut and tighten on the punch stem using the coupling wrench.
5. Insert the female die in the die block.
6. Tighten the setscrew against the female die (requires 3/16" Allen wrench).
7. Slide the die block around the setscrews on the platen table. **Do not** tighten the flanged nuts.
8. Switch the front control box toggle switch (reference Figure "A") to the "OFF" position. Disconnect the foot switch from the receptacle.
9. Start the machine. Use the front control box joystick in the jog down mode (reference Figure "C"), to move the beam downward. Stop beam movement when the bottom of the stripper foot is approximately 1/8" above the die block.
10. Align the punch and die visually and by hand movement of the die block. Jog down again slightly and align. Continue this procedure until the punch has passed through into the die.
11. Using the wrench supplied with the machine, tighten the flanged nuts on the setscrews to hold the die block firmly to the platen table.
12. Set the limit switches to control the length of stroke (reference procedures previously listed).
13. Start operation.

## STRIPPER ASSEMBLY ADJUSTMENT

**NOTE:** The selector switch should be in the "OFF" position until all tooling changes are complete. (Reference Page 12, Figure "B".)

The adjustment of the stripper assembly to compensate for varying punch lengths should be accomplished in the following manner. (Reference Page RP-8 for a visual reference).

**NOTE:** The correct adjustment should have the tip of the punch 1/16" below the bottom of the stripper footplate and the stripper footplate level.

1. Install the stripper assembly on the upper beam (reference instructions previously listed).
2. Insert punch in the stripper assembly (reference instructions previously listed).
3. Measure the length of the punch relative to the bottom of the stripper foot.
4. If the tip of the punch extends more than 1/16" below the bottom of the stripper foot, adjustment is required.
5. Turn the two (2) guide pin adjusting caps *counter clockwise* until the tip of the punch extends 1/16" below the bottom of the stripper footplate. The stripper footplate **MUST** remain level or parallel to the work material. The punch tip should be able to line up on a center punch mark before the stripper footplate engages the material.
6. If the tip of the punch does not extend 1/16" below the bottom of the stripper foot, or if the stripper footplate is not parallel with the work material, adjustment is required.
7. Turn the two (2) guide pin adjusting caps *clockwise* until the tip of the punch extends 1/16" below the bottom of the stripper footplate. The stripper footplate **MUST** remain level or parallel to the work material. The punch tip should be able to line up on a center punch mark before the stripper footplate engages the material.

## BENDING ATTACHMENT ALIGNMENT

The alignment of the bending punch and bending die should be accomplished by the following manner. (Reference Pages RP-3 and RP-10).

1. Slide the bending punch assembly on the dovetail-mounting shoe. The front edge of the bending dovetail slide should be even with the mounting shoe
2. Tighten the locking shoe by turning the cap screw clockwise (requires 3/8" Allen wrench). This locks the bending punch assembly firmly in place.
3. Place the bending base holders on the platen table over the setscrews. Do not tighten flanged nuts.
4. Place the four-way bending die into the bending base holder with the proper width die opening on the top.
5. Switch the front control box toggle switch (Reference Figure "A") to the "OFF" position and disconnect the foot switch from the receptacle.
6. Start the machine. Using the front control box joystick in the jog down mode (Reference Figure "C"), move the beam downward.
7. When contact between the bending punch and the bending die block opening is made, the bending die block will center itself.
8. Using the wrench supplied with the machine, tighten flanged nuts on the setscrews to hold the base assembly firmly to the platen.
9. Set the limit switches to control the length of stroke (reference procedures previously listed).
10. Start operation.

## SHEAR HOLD-DOWN ASSEMBLY ADJUSTMENT

The adjustment on the hold-down assembly should be accomplished by the following manner. (Reference Page RP-6)

1. Raise the upper beam to its full upstroke limit.
2. Adjust the three-position hold-down locator per the following instructions:
  - Locator hole nearest punch end - Plate = 1/4" thick and less, Angle = 3/16" thick and less.
  - Locator hole center position - Plate = 5/16" to 1/2" thick, Angle = 1/4" to 5/16" thick.
  - Locator hole nearest the coper end - Plate = 5/8" to 1" thick, Angle = 3/8" to 1/2" thick\*
3. Loosen the long hex head nut without removing it from the swing bolt, raising the hold-down assembly.
4. Assure the hold-down bar has risen until it is directly under the long nut.
5. Insert material to be sheared under the hold-down assembly.
6. Tighten the long hex head nut to allow for approximately 1/8" clearance between the bottom of the shear urethane and the top of the material to be sheared. The material should move freely and not be held by the hold-down assembly at this point.
7. Lower the beam using the front control box joystick in the jog mode (reference Figure "C") until the hold-down assembly firmly clamps the material.

**NOTE:** The hold-down assembly must firmly clamp the material before the shear knives engage the material surface.
8. If the foot switch is to be used during the operation, adjust the limit switches to control the length of stroke (reference procedures previously listed).

## LUBRICATION

### GENERAL

The importance of correct lubrication cannot be over emphasized. Under no circumstances should the machine be operated without complying with the lubrication requirements set forth in this publication.

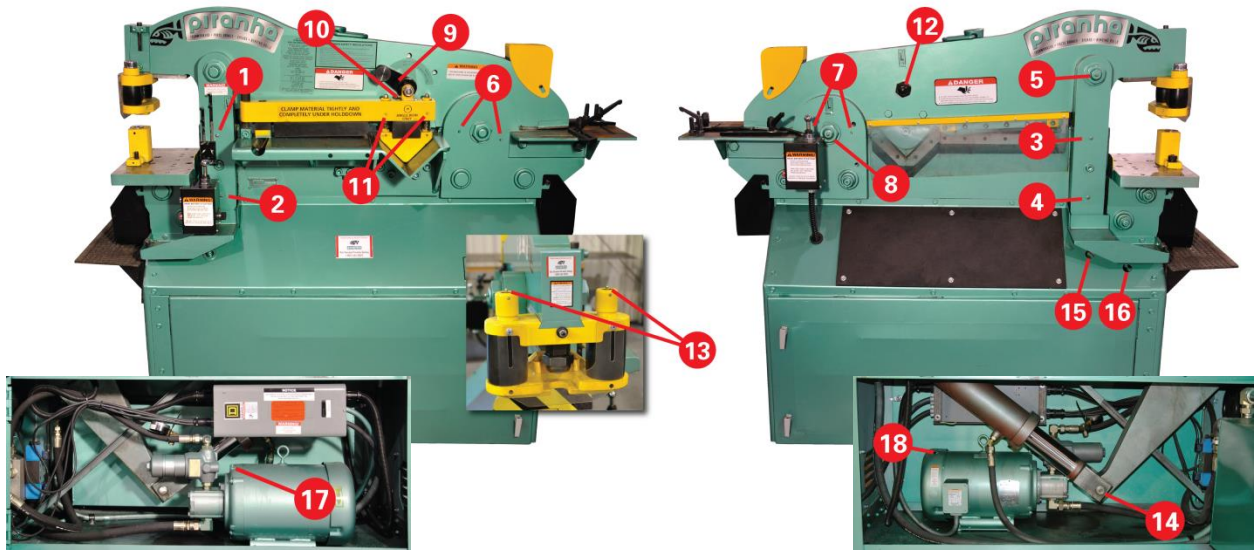

### LUBRICATION CHART

Station	Part Lubricated	Frequency	Instructions	Lubrication Type
1	Upper Pull Arm On Side	Every 40 hours or weekly with normal use	Apply With Grease Gun Until Grease Appears Around Edge Of Parts	Mobile MP Or Any Multi-Purpose Grease
2	Lower Pull Arm On Side			
2	Upper Pull Arm Off Side			
4	Lower Pull Arm Off Side			
5	Upper Pull Arm Hinge Pin			
6	Coper Side Plate On Side (2 Places)			
7	Coper Side Plate Off Side (2 Places)			
8	Rear Hinge Pin			
9	Angle Knife Bushing			
10	Hold-down Link			
11	Hold-down Bar (2 Places)			
12	Hold-down Pin			
13	Stripper Assembly (2 Places)			
14	Clevis Pin			
15	Lower Pull Arm Hinge Pin			
16	Crank Arm Hinge Pin			
17	Drive Motor	One Shot Per Year	One Shot From Grease Gun	Multi-Purpose Grease
18	Drive Motor			

## MAINTENANCE

**NOTE:** The Selector Switch should be in the "OFF" position while maintenance checks are being performed. Reference Page 12, Figure "B".

### HYDRAULIC FILTER ELEMENT

The hydraulic oil filter is a vital component of the hydraulic system as it filters impurities and foreign particles to avoid hydraulic component malfunctions.

**CAUTION:** When the filter element is plugged, hydraulic fluid will by-pass the element, allowing contamination to enter the hydraulic system. It is recommended that the filter element be changed every three-(3) months, depending on workload and environmental conditions. One extra element is furnished with the basic unit. This element should be installed after the first 40 hours of use. The filter housing is mounted inside the access door on the machine. Reference: Repair Parts List for reordering instructions and the item number 7, Page RP-17.

### FASTENERS AND CONNECTIONS

The efficiency and accuracy of the Piranha is dependent upon proper alignment of all parts. Alignment can only be achieved by keeping the fasteners tight. Check all bolts and nuts for tightness every 40 hours of operation, or when lubricating the machine. Unless specified in parts illustrations, torque socket head bolts and hinge pin jam nuts to the specifications in the table on Page 27.

Check all hydraulic hose and fitting connections for tightness when lubricating the machine. We recommend you use Loctite hydraulic sealant or an equivalent product on all connectors.

Check to insure the hydraulic cylinder clevis is screwed tight on the piston rod each time machine is lubricated.

### HYDRAULIC OIL LEVEL

Your Piranha ironworker is equipped with a dipstick indicator on the fill cap located inside the access door. The dipstick is marked to help maintain proper fluid level. This should be checked as part of your normal maintenance cycle.

**NOTE:** We recommend that you implement a weekly maintenance program to inspect and lubricate your Piranha. For your convenience, a service record chart has been provided on Page RP-23.

## **TROUBLESHOOTING**

The following material is a troubleshooting guide to be followed by maintenance personnel should a problem occur with your machine. Many of these problems can be solved in your shop by following a step-by-step procedure for isolating the deficiency. If the deficiency cannot be isolated and corrected in your shop, any information regarding your effort to isolate the area should be related to the service technician at Mega Manufacturing, Inc. to assist him in finding a solution. These efforts will assure restoring your machine to full operational status with the minimum amount of downtime.

### **POTENTIAL PROBLEMS AND SOLUTIONS**

#### **P1 - MACHINE WILL NOT START**

1. Check that selector switch is turned to the control box you are starting the machine from.
2. Check fuses at disconnect.
3. Check voltage to motor starter.
4. Transformer control voltage (Output - 120 V). If not, check:
  - A. Transformer fuse. If blown, inspect circuit for a ground short.
  - B. Incoming voltage to input side of transformer is correct and the jumper bars are in the correct location. Reference Page RP-12 and RP-13.
  - C. All wire and fuse holder connections are tight.
  - D. Possible faulty transformer.
5. Control circuit from transformer to front and rear control boxes to motor starter coil. (Reference Wiring Diagram Page RP-13).

## **P2 - MACHINE STARTS BUT WILL NOT OPERATE**

Determine if the problem is electrical or hydraulic by using the manual override buttons located on the Rexroth directional valve top and bottom sides. (Refer to Page RP-18, Item 9).

If the machine operates, the problem is electrical. Follow the procedure below:

1. Determine if problem exists in the front control box only, the rear control box only, or in both control boxes.
  - A. If problem is isolated to one box only, check the internal wiring and wiring harness with disconnect plug for loose connection.
  - B. If the problem exists in both boxes, follow the remaining procedures.
2. Check wiring connections in the electrical enclosure.
3. Check the valve body wiring harness, including the disconnect plugs, for loose connections.
4. Check coils in the directional control valve.

**If the machine does not operate on manual override, the problem is hydraulic.**

1. Check to determine if the pump is developing flow. If not:
  - A. See if motor rotation is correct.
  - B. Check motor / pump coupling (in models prior to S/N P3-5893) for tightness on both shafts; and also check that insert is not damaged.
  - C. Check hydraulic suction line for tightness.
  - D. Check Oil level.
  - E. If the above checks out okay, the pump may be defective
2. Check to determine if the spool in the directional control valve is stuck in the center position. If the valve is stuck, remove the end caps of the control valve and free the spool. Inspect for contamination.



### **P3 - MACHINE OVERHEATS**

1. Check if fluid level in reservoir is low.
2. Check for low line voltage to transformer, causing low control voltage to directional valve solenoid coils.
3. Determine if limit switches are set improperly when using footswitch, allowing cylinder to bottom out at retraction and extension. This may cause hydraulic fluid to by-pass over relief valve, creating heat buildup.
4. If jog mode is used during production, hydraulic fluid may pass over the NC valve and create heat buildup.
5. Check for restrictions in the hydraulic system. Example: Contaminated cartridge valve, restricted or kinked hose, etc.

### **P4 - RESET ON MOTOR STARTER KICKS OUT**

1. Internal overheating. Refer to P3, above, for troubleshooting procedure.
2. Insure proper sized heater coils are being used. (Reference the wiring diagram on Page RP-13).
3. Check for proper line voltage.
4. Check for loose connections on motor cable at starter or motor.

### **P5 - EDGES ON KNIFE BLADE CHIPPED BY MATERIAL**

1. Check knife clearance - .007" to .010". If not:
  - A. Combo table bolts may have become loose, allowing scale and contamination between table and beam. Remove table and clean.
  - B. Combo table bolts may have stretched the threads in the beam. Remove table and sand beam surface flat.
  - C. Knives may have been ground. Shim to recommended clearance.
2. Knives may be dull and are creating a pulling effect on the shearing edge.
3. Material may be too hard.
4. Material may be thicker than rated capacities.

## **P6 - MACHINE LEAVES BURR WHEN SHEARING**

1. Knife clearance: .007" to .010". If not, follow procedure in P5.
2. Check shear knives for sharpness
3. Check that the automatic hold-down is adjusted to clamp the material securely.

## **P7 - BENT OR BROKEN SHEAR HOLD-DOWN SWING BOLT**

1. Check that the alignment of the angle hold-down block with the angle table is square with table.
2. Check to see if the spiral pins holding the guide pins to the angle block are sheared.
3. Check that hold-down link moves freely in the hold-down bar.
4. Check that wing bolt moves freely in the hold-down bar.
5. Check that the three-position hold-down is in proper location for material being sheared. (Reference the hold-down assembly adjustment on Page 19.)

## TONNAGE REQUIRED FOR PUNCHING HOLES IN MILD STEEL

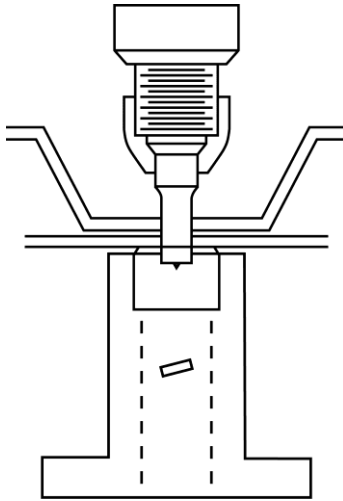

The table below shows the tons of pressure required for punching round holes in mild steel derived by the following formula:

Tons of pressure required = Hole Size x Material Thickness x a Constant of 80.

All figures shown are in tons. For intermediate sizes, interpolations can be made.

Tonnage for round hole sizes larger than 1" can also be computed.

Example: What pressure is required to punch a 2-1/4" round hole in 7/8" thick material?

Since a 1" round hole in 7/8" thick material requires 70 tons of pressure, a 2-1/4" round hole in 7/8" thick material required is 157.5 tons. 2.25" round hole x 70 tons = 157.5

**WARNING! Do not punch hole smaller than the thickness of the material!**

Material Thickness	Punch Size														
	1/8	3/16	1/4	5/16	3/8	7/16	1/2	9/16	5/8	11/16	3/4	13/16	7/8	15/16	1
3/32	1	1	2	2	3	3	4	4	5	5	5	6	7	7	8
1/8	1	2	3	3	4	4	5	6	6	7	8	8	9	9	10
3/16		3	4	5	6	7	8	9	9	10	11	12	13	14	15
1/4			5	6	8	9	10	11	13	14	15	16	18	19	20
5/16				8	9	11	13	14	16	17	19	20	22	23	25
3/8					11	13	15	17	19	21	23	24	26	28	30
7/16						15	18	20	22	24	26	28	30	33	35
1/2							20	23	25	28	30	33	35	38	40
9/16								26	28	30	34	36	40	42	45
5/8									31	34	38	41	44	47	50
11/16										38	41	44	48	51	55
3/4											45	49	53	56	60
13/16												53	57	61	65
7/8													61	66	70
15/16														71	75
1															80

## MAINTENANCE TOOLS LIST

The following tools are required for performing maintenance and to assist you in troubleshooting your machine:

1. Grease gun with a flexible connection.
2. Open end wrenches - 3/4" thru 1-1/4".
3. Adjustable wrench – 1-1/2" thru 2-1/4" opening.
4. Allen wrenches - 3/16" thru 5/8".
5. Screwdrivers - miscellaneous sizes.
6. Voltmeter.

### RECOMMENDED FASTENER TORQUE SPECIFICATIONS (Unless Otherwise Specified)

Bolt Size	Torque (Ft-Lbs)
3/8-16	45
7/16-14	70
1/2-13	100
5/8-11	210
3/4-10	375
Jam Nuts	600

### DIE CLEARANCE CHART FOR STEEL

Gauge	Decimal Thickness	Die Clearance (Add to Punch Size)
13 thru 11	0.089 – 0.125"	0.01"
10 thru 7	0.126 – 0.190"	1/64" (0.016")
Over 7 thru 1/2" Plate	0.191 – 0.500"	1/32" (0.032")
Over 1/2" Plate	Over 0.500"	1/16" (0.063")

## **ORDERING REPAIR PARTS FOR A PIRANHA**

The following assembly parts lists are shown in four columns. In the first column are the index numbers of the parts illustrated. The second column contains the Mega Manufacturing part number, followed by the description in the third column. The last column shows the quantity of parts required for the assembly.

Electrical wiring diagrams and hydraulic diagrams are shown with the Piranha part numbers. Some of these items shall be considered as an assembly and only one part number will be given, even though they are comprised of component parts.

You will receive quicker service when ordering repair parts by adhering to the following procedure.

1. Provide the complete serial number of the machine. The machine serial number is stamped on the nameplate and is located on the right hand side of the machine (when facing the punch end).
2. Provide part number, description, and the quantity of parts that you require.
3. Specify each individual piece required. Do NOT use the term "complete assembly".
4. Specify how and where to ship. Define the method of transportation desired. UPS, Old Dominion, and FedEx Freight, are the most frequently used carriers at Mega Manufacturing.

**ALWAYS PROVIDE THE COMPLETE SERIAL NUMBER  
FOR PARTS AND SERVICE**

## REPAIR PARTS ILLUSTRATIONS

	<b>Page No.</b>
Basic Machine.....	RP-3
Shear Hold-down Assembly.....	RP-6
Stripper Assembly.....	RP-8
Bending Assembly .....	RP-10
Electrical Enclosure .....	RP-12
Electrical Schematic.....	RP-13
Front Control Box.....	RP-14
Rear Control Box .....	RP-15
Valve Body Assembly .....	RP-16
Hydraulic Schematic .....	RP-17
Motor, Filter, and Pump Assembly .....	RP-18
Cylinder Assembly .....	RP-19
Foot Pedal Assembly .....	RP-20
Knives (No Illustration).....	RP-21
Service Record Chart.....	RP-23

# P-90 BASIC MACHINE

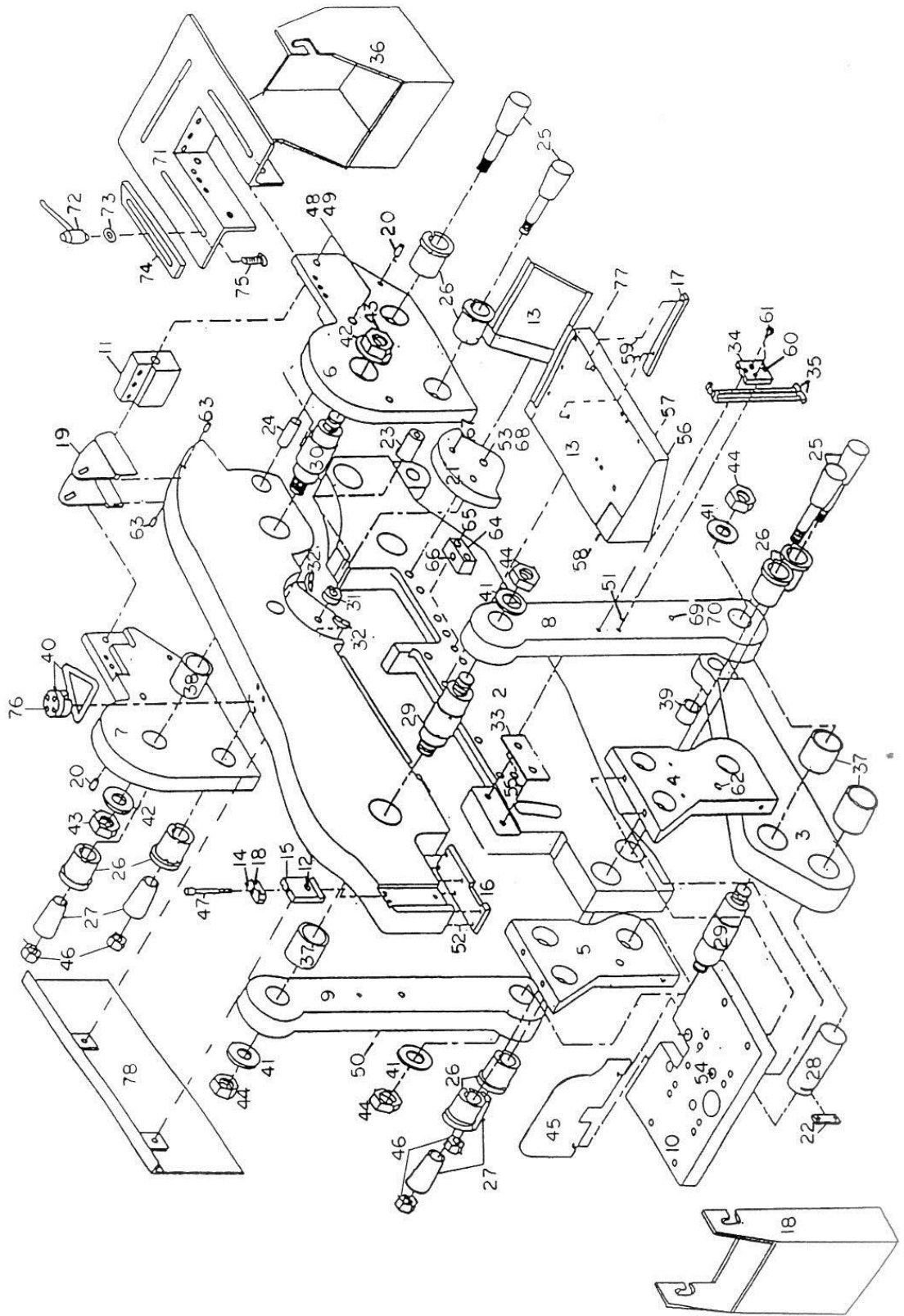

## P-90 BASIC UNIT

Figure And Index No.	Part Number	Description	Qty.
1	0250100	Upper Beam Assembly	1
2	0250101	Lower Beam Assembly	1
3	0250112	Crank Arm Assembly	1
4	0250113	Platen Support-On Side	1
5	0250114	Platen Support-Off Side	1
6	0250115-1	Coper Side Plate-On Side	1
7	0250116-1	Coper Side Plate-Off Side	1
8	0250110	Pull Arm-On Side	1
9	0250111	Pull Arm-Off Side	1
10	0250120	Platen Table	1
11	0250117-1	Coper End Knife Support	1
12	0340189	Locking Shoe Bolt	1
13	0250121	Combo Table	1
14	0240130	Locking Shoe Bearing	1
15	0240131	Locking Shoe	1
16	0250132	Mounting Foot	1
17	0250140	Plate Shear Guide	1
18	0250145	Punch End Chip Bucket	1
19	0240142	Coper Guard	1
20	0531351	3/8" x 1" Roll Pin	2
21	0250146	Angle Knife cover	1
22	0240148	Crankarm Pin Lock Plate	1
23	0250154	Urethane Spacer	1
24	0250155	Black Pipe Spacer	1
25	0250160	Taper Pin	4
26	0250161	Taper Pin Split Bushing	8
27	0250163	Taper Pin Plug	4
28	0250164S	Crankarm Hinge Pin	1
29	0250165S	Pull Arm Hinge Pin	2
30	0250166	Rear Hinge Pin	1
31	0240167	Angle Knife Bushing	1
32	0240168	Angle Knife Block	2
33	0230145	Bronze Wear Plate	1
34	0230149	Microswitch Guide Block	1
35	0230153	Microswitch Arm Assembly	2
36	0250143	Coper End Chip Bucket	1
37	0350168	Crankarm Bushing	3



## P-90 Basic Unit – Continued

Figure And Index No.	Part Number	Description	Qty.
38	0350170	Rear Hinge Pin Bushing	1
39	0350169	Cylinder Pin Bushing	1
40	0541400	Lifting Lug	1
41	0541303	Thrust Washer	4
42	0541303	Thrust Washer	2
43	0541250	2" Jam Nut	2
44	0541250	2" Jam Nut	4
45	0250150	Pull Arm Guard	1
46	0541215	Hex Nut	4
47	0551150	1/2" x 3-1/4" SHCS	1
48	0531250	3/4" Nylock Nut	2
49	0551165	3/4" x 9" Hex Head Bolt	2
50	0551162	3/4" x 8" SHCS	1
51	0541127	3/4" Jam Nut	1
52	0541090	7/16" x 1" SHCS	6
53	0531250	5/8" Nylock Nut	1
54	0531092	5/8" x 2-1/4" SHCS	4
55	0531062	3/8" x 3/4" Flat Head SCS	2
56	0541175	3/4" x 5-1/2" SHCS	1
57	0541115	1/2 x 5-1/2" SCHS	1
58	0531216	1/2" Nylock Hex Nut	1
59	0531000	1/4" x 1/2" SHCS	2
60	0531001	1/4" x 3/4" SHCS	2
61	0531320	1/4" x 1/2" Thumbscrew	2
62	0531351	3/8" x 1" Roll Pin	2
63	0531351	3/8" x 1" Roll Pin	2
64	0240157	Plate Table Adjusting Block	1
65	0541150	3/4" x 1-3/4" SHCS	2
66	0531087	1/2" x 2" SSS	1
67	0551155	5/8" x 3" Hex Head Bolt	2
68	0551160	3/4" x 3-1/4" Shoulder Bolt	1
69	0531005	1/4" x 1/2" Button Head Cap Screw	1
70	0581140	1/4" Hex Nut	1
71	0250124	Coper Table Assembly	1
72	0531715	Jergens Handle	3
73	0531307	1/2" Flat Washer	3
74	0330128	Coper Table Guide	3
75	0531088	1/2" x 1-1/2" Carriage Bolt	3
76	0531086	1/2" x 1-3/4" SHCS	4
77	0541155	3/4" x 2-1/4" SHCS	9
78	0250415	Shear Guard Assy.	1

# P-90 SHEAR HOLD-DOWN ASSEMBLY

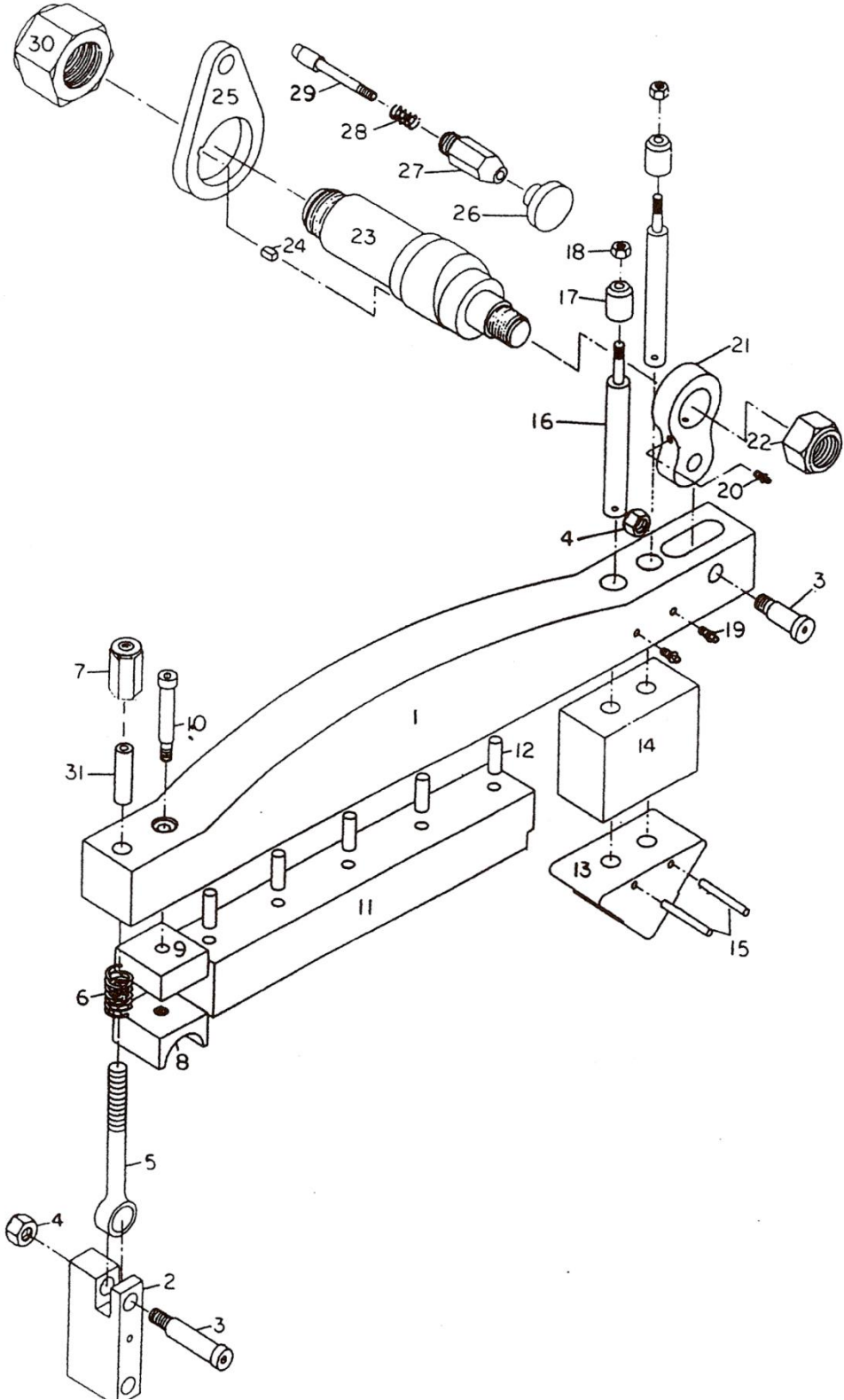

ALWAYS PROVIDE THE COMPLETE SERIAL NUMBER FOR PARTS AND SERVICE

RP-6

**P-90 HOLD DOWN ASSEMBLY**  
**PART NUMBER 0250200**

<b>Figure And Index No.</b>	<b>Part Number</b>	<b>Description</b>	<b>Qty.</b>
1	0350200	Hold Down Bar	1
2	0240206	Swingbolt Block	1
3	0541160	3/4" x 2-3/4" SB	2
4	0531250	5/8" Nylock Nut	2
5	0541395	CL-76 Swingbolt	1
6	0340217	Swingbolt Spring	1
7	0541396	CL-4 Coupling Nut	1
8	0340205	Round Bar Block	1
9	0340209	Round Bar Urethane	1
10	0541112	1/2" x 3-1/4" SB	1
11	0350207	Shear Urethane	1
12	0531352	1/2" x 1-1/2" Roll Pin	5
13	0340204	Angle Block	1
14	0350208	Angle Urethane	1
15	0541062	5/16" x 2-1/2" Spiral Pin	2
16	0350201	Angle Guide Pin	2
17	0340211	Angle Guide Pin Sleeve	2
18	0531212	3/8" Nylock Nut	2
19	0531360	1610 B Zerk	2
20	0531363	1636 B Zerk	1
21	0340202	Hold Down Link	1
22	0541225	1-1/4" Nylock Jam Nut	1
23	0250201	Hold Down Pin	1
24	0340215	Hold Down Pin Key	1
25	0350215	Locator Plate	1
26	0541393	Locator Pin Knob	1
27	0340213	Locator Pin Housing	1
28	0340216	Locator Pin Spring	1
29	0340212	Locator Pin	1
30	0531270	1-1/2" NF Jam Nut	1
31	0350210	Hold Down Bar Bushing	1

# P-90 STRIPPER ASSEMBLY

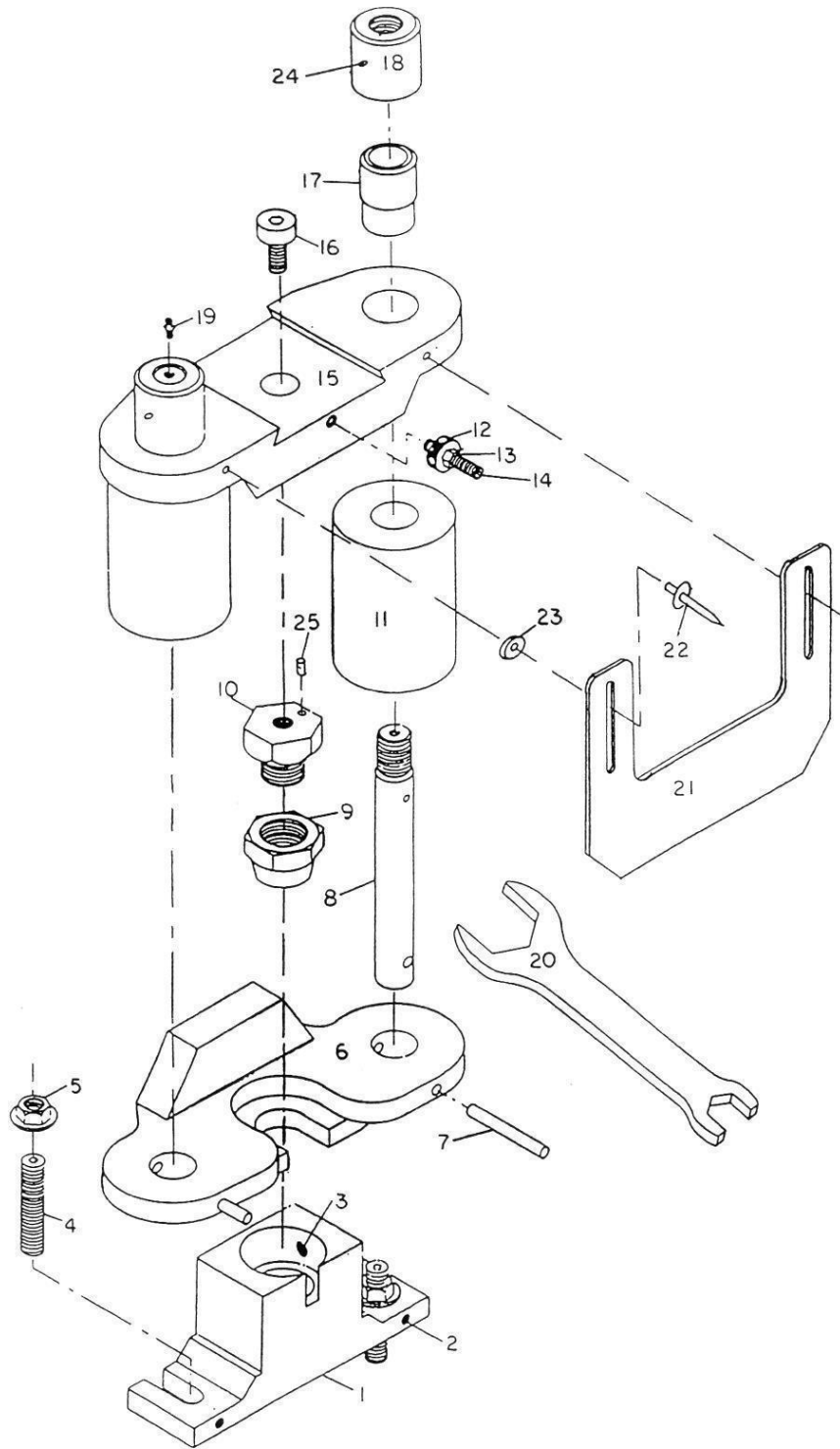

**P-90 STRIPPER ASSEMBLY**  
**PART NUMBER 0250401**

<b>Figure And Index No.</b>	<b>Part Number</b>	<b>Description</b>	<b>Qty.</b>
1	0240400	Die Block	1
2	0531002	1/4" X 3/4" SSS	3
3	0541085	7/16" - 14 x 3/4" SSS	1
4	0541127	5/8" x 3-1/2" SSS	2
5	0531251	5/8" FLGD Nut	2
6	0340401	Stripper Foot Assembly	1
7	0531356	3/8" x 2-1/2" Spiral Pin	2
8	0340402	Stripper Guide Pin	2
9	0340406	C-58 Coupling Nut	1
10	0340407	Punch Stem	1
11	0340403	Urethane Stripper Block	2
12	0531211	3/8" Knurled Nut	1
13	0531210	3/8" Hex Nut	1
14	0531058	3/8" x 2" SSS	1
15	0350404	Punch Dovetail Slide	1
16	0541150	3/4" x 1-3/4" SHCS	1
17	0340409	Stripper Guide Pin Slip Sleeve	2
18	0340408	Stripper Guide Pin Adjusting Cap	2
19	0531360	1610 Zerk	2
20	0241410	Coupling Wrench	1
21	0340400	Punch Guard	1
22	0531012	Punch Guard Rivets	2
23	0531013	Punch Guard Spacer	2
24	0541045	W-17N Ball Plunger 1/4" - 20"	2
25	0531350	1/4" x 3/4" RP	1

# P-90 BENDING ASSEMBLY (OPTIONAL)

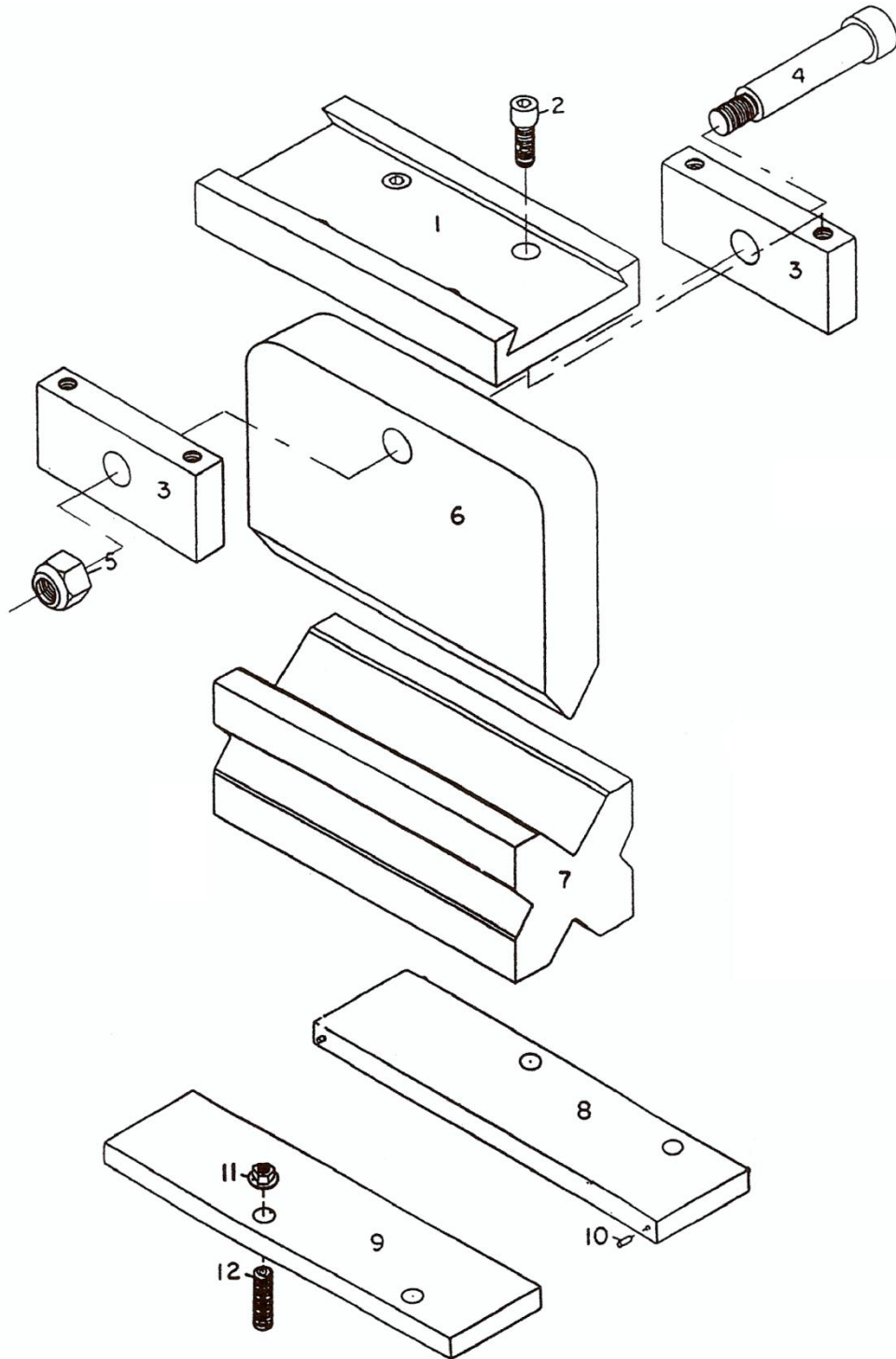

**P-90 12" BENDING ASSEMBLY (OPTIONAL)**  
**PART NUMBER 4451648**

<b>Figure And Index No.</b>	<b>Part Number</b>	<b>Description</b>	<b>Qty.</b>
1	0350500	Bending Dovetail Slide	1
2	0531039	3/8" x 3/4" SHCS	4
3	0340501	Bending Punch Slide Plate	2
4	0531114	3/4" x 3" Shoulder Bolt	1
5	0531250	5/8" Nylock Nut	1
6	0340502	12" Bending Punch	1
7	0340503	12" 4 way Bending Die	1
8	0350504	Die Holder with Pins	1
9	0350505	Die Holder without Pins	1
10	0531351	3/8" x 1" Roll Pin	4
11	0531251	5/8" FLDG Nut	4
12	0541127	5/8" x 3-1/2" SSS	4

**BENDING DIE CAPACITIES**

<b>"V" WIDTH</b>	<b>MAXIMUM MATERIAL</b>
3"	3/8"
2"	1/4"
1-1/2"	3/16"
7/8"	10 Gauge

## P-90 ELECTRICAL ENCLOSURE ASSEMBLY

### PART NUMBER 02316402-1

Figure And Index No.	Part Number	Description	Qty.
1	0521634	Rear Wiring Harness Receptacle	1
2	0521634	Front Wiring Harness Receptacle	1
3	0521636	Valve Body Harness Receptacle	1
4	0531641	Starter	1
5	T2253	Auxiliary Contact	1
6	05316261	220 / 440 Volt Transformer	1
OR	05316271	575 Volt Transformer	1
OR	05316281	208 Volt Transformer	1
7	05316221	Fuse Block	1
8	0531606	MDX-3 Fuse	1
9	0531639	220 Volt Heater Coil B-40	3
OR	0531634	440 Volt Heater Coil B-19.5	3
OR	0531635	575 Volt Heater Coil B-17.5	3
10	T0771	208/230 Volt Fuse ATQR 1.5	2
OR	T0794	440/575 Volt Fuse ATQR 6/10	2
Not Shown	03316512-1	Valve Body Wiring Harness	1

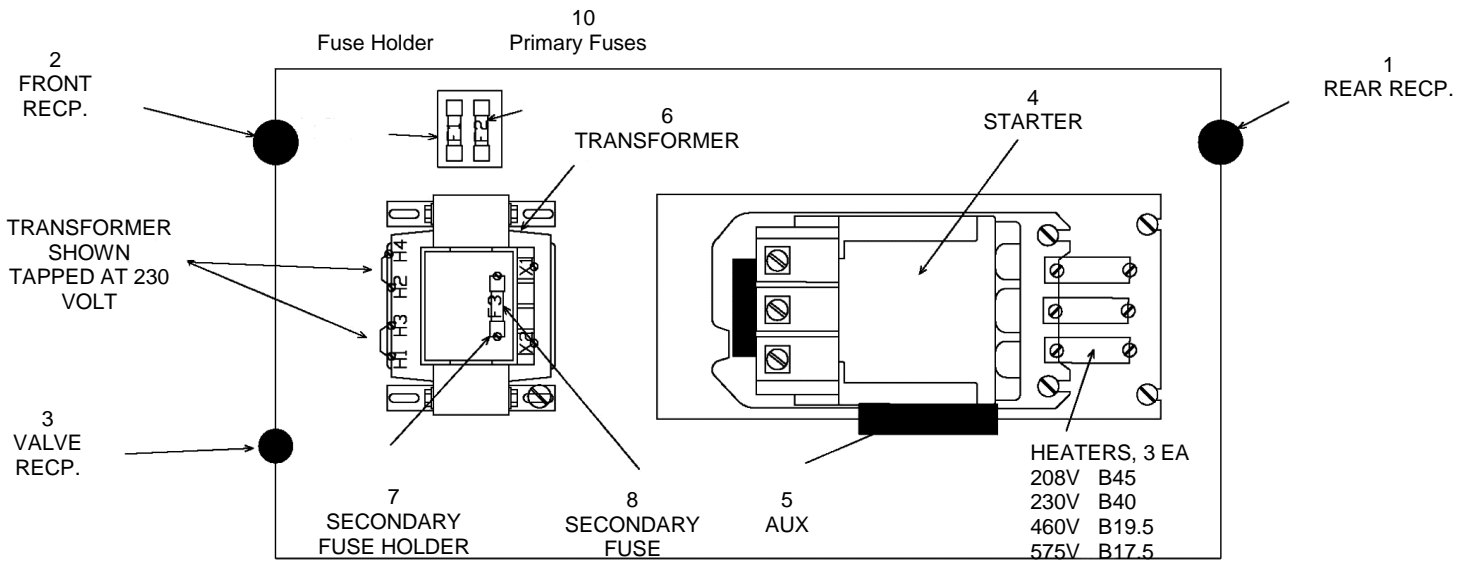



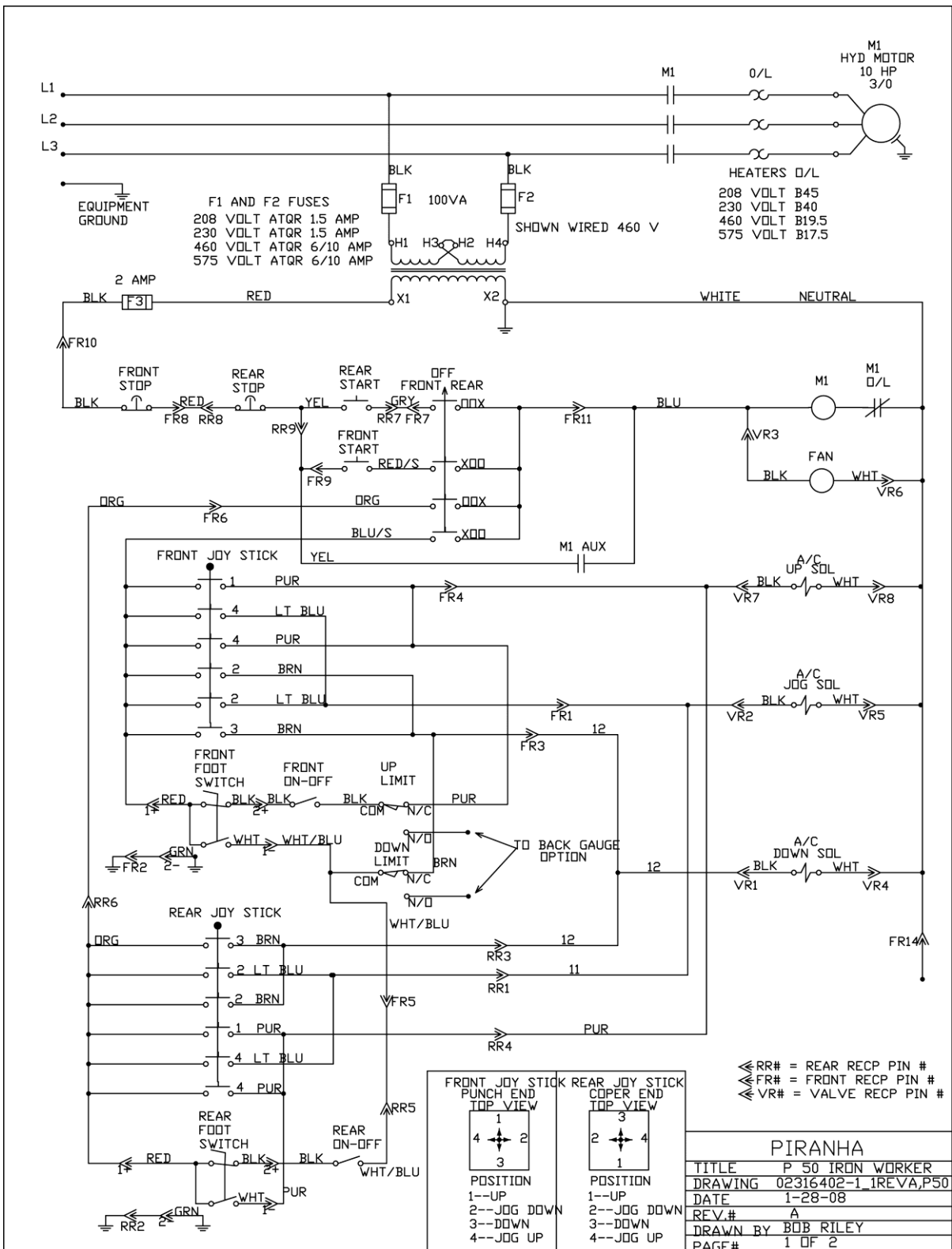

## P-90 FRONT BOX ASSEMBLY

### PART NUMBER 02316292-1

Figure And Index No.	Part Number	Description	Qty.
1	05316291	Front Control Box - With Covers	1
2	0531608	Joystick 9001 K35	1
3	0531609	KA-1 Contact Block	2
4	0531644	KA-2 Contact Block	2
	0531608-1	Joystick Assembly including items 2, 3, and 4 (for ordering as a repair part)	
5	05316451-1	Selector Switch ZB4BD3	1
6	0531616	Microswitch	2
7	05316101-1	Start Button ZB4BA3	1
8	05316111-1	Stop Button ZB4BL4	1
9	05316121-1	Contact Block w / base N.C. ZB4BZ102 (Contact Number ZB4BE102)	1
10	0531618	4 Pole Receptacle	1
11	0531619	Toggle Switch	1
12	05316461	Legend Plate, Front-Off-Rear, ZB2BY2002	1
13	0531654	Liquid Tight Connector, 3/8"	1
14	0531657	JIC Grey Conduit	1
15		Flexguard	1
16		Quick Disconnect Plug	1
17	05316781-1	Contact Block ZB4BE101	2
18	0531678-1	Mounting Base with 2 each N.O. Contacts *ZB4BZ103	1
19	0531696-1	Contact Block w/base ZB4BZ101*	1

\* Replacement contacts for item Number 18 requires 2 each of part Number ZB4BE101. Item Number 19 requires 1 each.

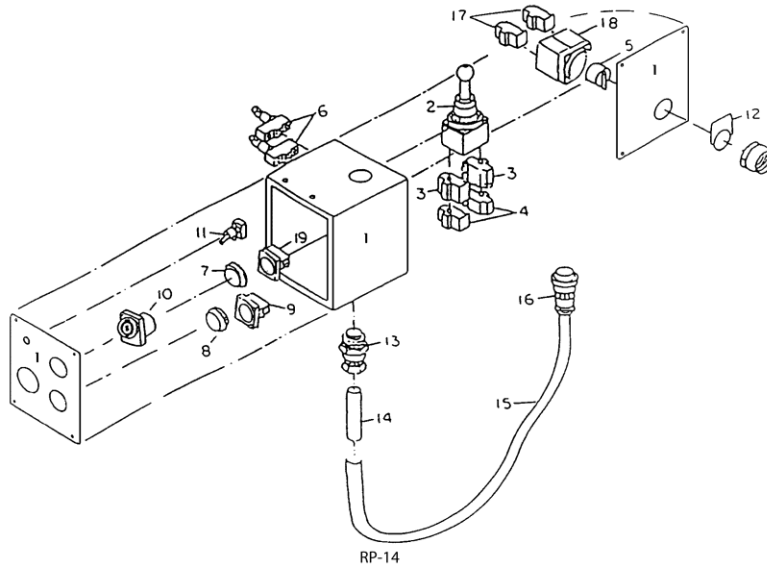

**P-90 REAR BOX ASSEMBLY**  
PART NUMBER 02316302-1

Figure And Index No.	Part Number	Description	Qty.
1	05316301	Rear Control Box - With Covers	1
2	0531608	Joystick 9001 K35	1
3	0531609	KA-1 Contact Block	2
4	0531644	KA-2 Contact Block	3
	0531608-1	Joystick Assembly including items 2, 3, and 4 (for ordering as a repair part)	
5	05316101-1	Start Button ZB4BA3	1
6	05316111-1	Stop Button ZB4BL4	1
7	05316121-1	Contact Block with base N.C. ZB4BZ102 (Contact Number ZB4BE102)	1
8	0531618	4 Pole Receptacle	1
9	0531619	Toggle Switch	1
10	0531654	Liquid Tight Connector 3/8"	1
11	0531657	JIC Grey Conduit	1
12		Flexguard	1
13		Quick Disconnect Plug	1
14	0531696-1	Contact Block with base ZB4BZ101 (Contact Number ZB4BE101)	1

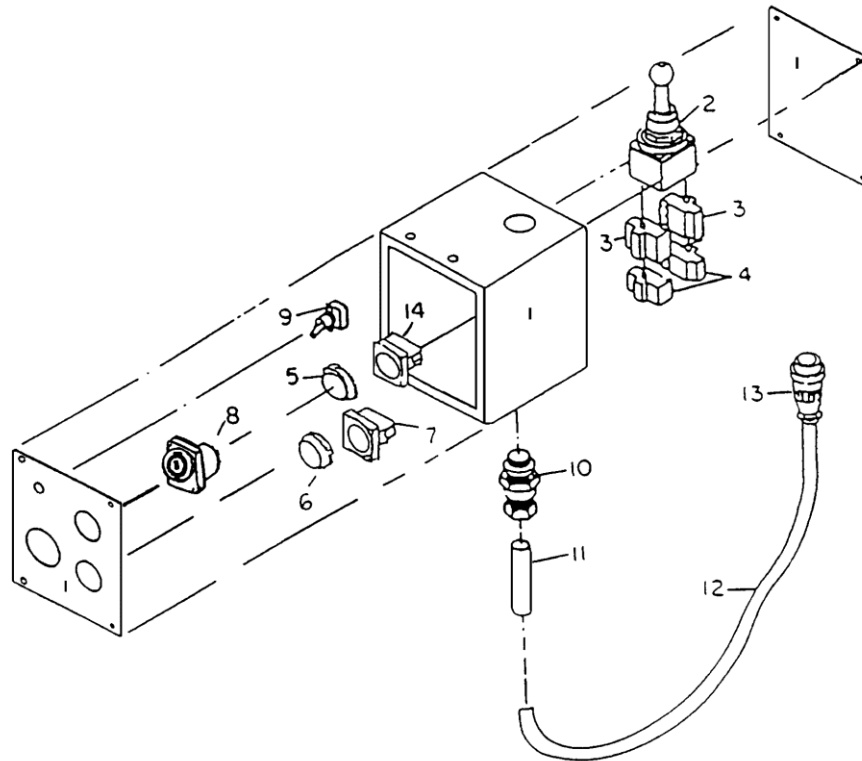

# P-90 VALVE BODY ASSEMBLY

## PART NUMBER 0231530-2

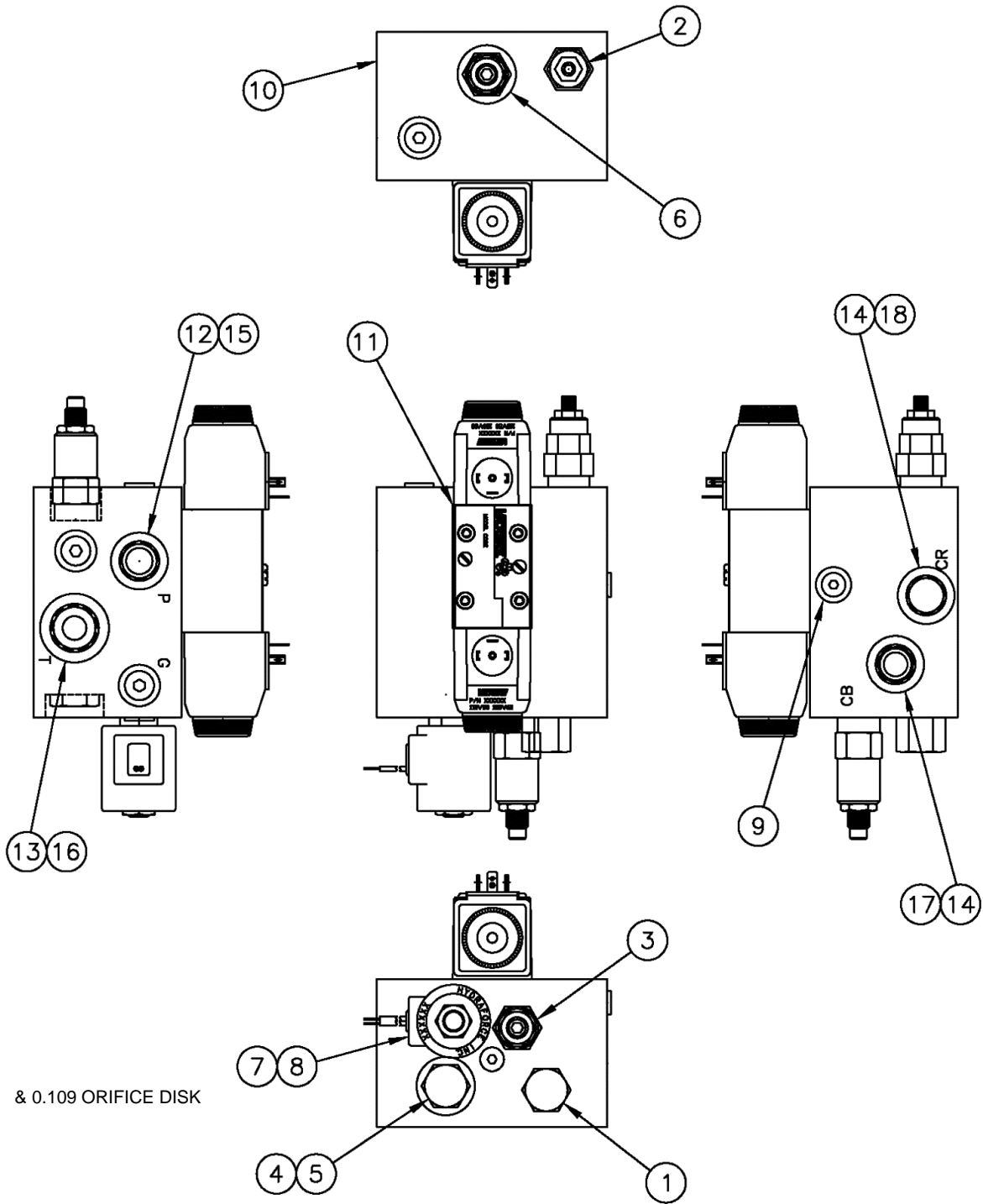

& 0.109 ORIFICE DISK

BEGINS WITH S/N xxxx

## P-90 VALVE BODY ASSEMBLY PART NUMBER 0231530-2

Figure And Index No.	Part Number	Description	Qty.
1	T3572	Pilot Valve 2-Way	1
2	0551566-1	Counterbalance Valve	1
3	0551559-1	Pressure Relief Valve 35/26	1
4	0531567-1	Check Valve	1
5	0531566-1	Single Pilot Piston Valve	1
6	0531562-1	Pressure Relief Valve 25/12	1
7	0551561-1	Solenoid Valve (N.C.)	1
8	T3574	115V AC Solenoid Coil	2
9	0541535-1	Shuttle Valve	1
10	0531530-1	Valve Body	4
11	0531574-1	Directional Control Valve 4-way	1
12	0531531	6801-12 Fitting	1
13	0541505	6802-12 Fitting	1
14	0541505	6802-12 Fitting	2
15	0551522	48" Hose To Filter Assembly	1
16	0531543	32" Hose To Tank	1
17	0551521	55" Hose To Cylinder	1
18	0551520	40" Hose To Cylinder	1
19	03316512-2	Valve Body Wiring Harness (not shown)	1

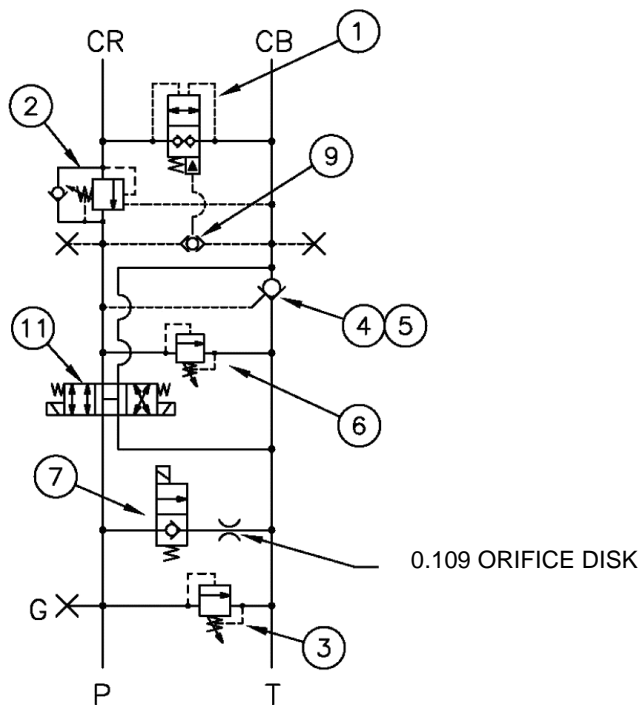

HYDRAULIC SCHEMATIC

## P-90 MOTOR ASSEMBLY PART NUMBER 0231600-1

Figure And Index No.	Part Number	Description	Qty.
1	05316612	10 HP Motor 220/440V (Hollow Shaft)	1
OR	05316652	10 HP Motor 575V (Hollow Shaft)	1
OR	05316702	10HP Motor Single Phase (Hollow Shaft)	
2	0533539	6801-16 Hydraulic Fitting	1
3	05315961-2	Hydraulic Pump	1
4	0531050	3/8" x 1" SHCS	2
5	0531515-1	6403-10-12-NWO	1
6	0521550-2	Filter Assembly 4" Pall	1
7	0521551-2	Filter Element 4" Pall	1
8	0531508	6801-10-12LP JM6 Hydraulic Fitting	1
9	0551523	27" Hose To Tank	1
10	0551521	55" Hose To Valve Body	1
11	0541531	304-C-6 Hydraulic Fitting	1
12	0531514	6503-6-4 Hydraulic Fitting	1
13	0541542	Pressure Gauge PGD-25-5000S	1

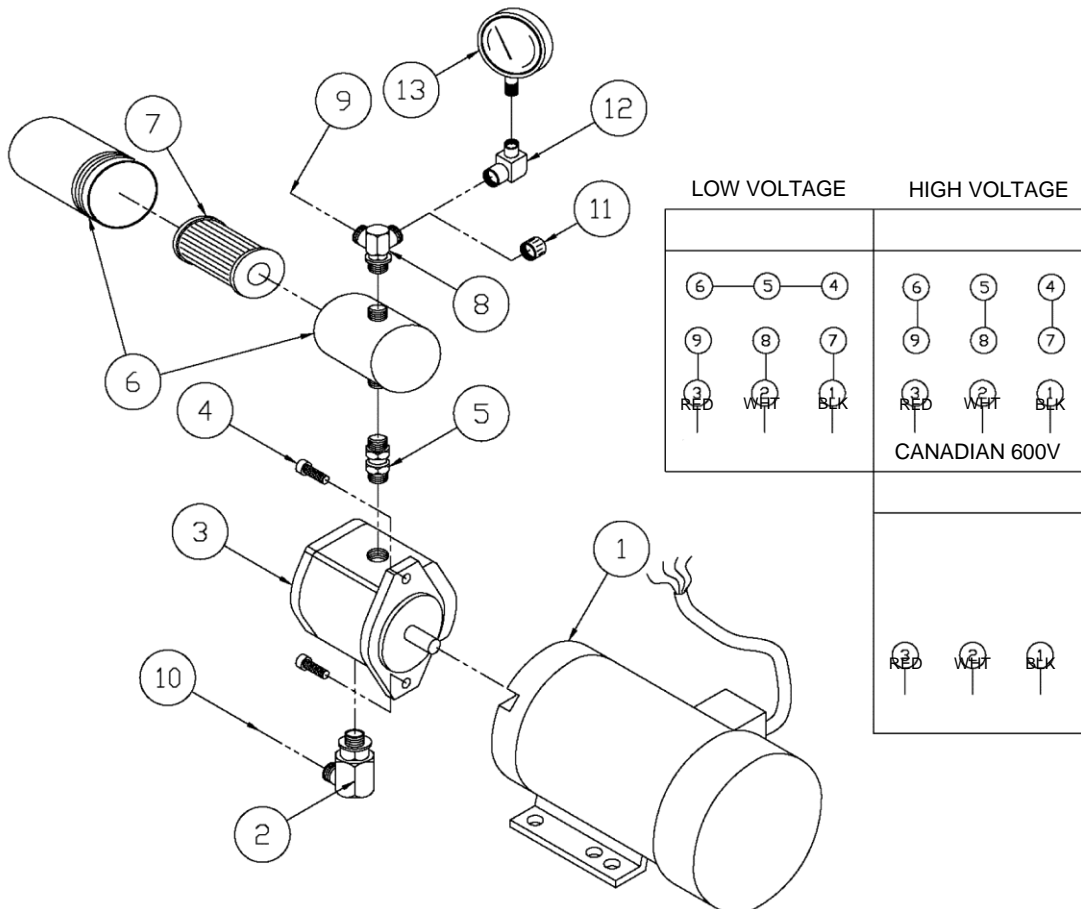

## P-90 CYLINDER ASSEMBLY

Figure And Index No.	Part Number	Description	Qty.
1	0551503	Cylinder #13150	1
2	0240171S	Cylinder Clevis Pin	2
3	0531360	16105 Zerk 1/8" P Thread	2
4	0250152	Cylinder Clevis	1
5	0531085	1/2" x 1/2" SSS	1
6	0541310	5108-200 Snap Ring	4
7	0531531	6801-12 Fitting	1
8	0531538	6801-12-16 Fitting	1
9	0551521	55" Hose to Valve Body	1
10	0551520	40" Hose to Valve Body	1
11	05415001	Seal Kit	1

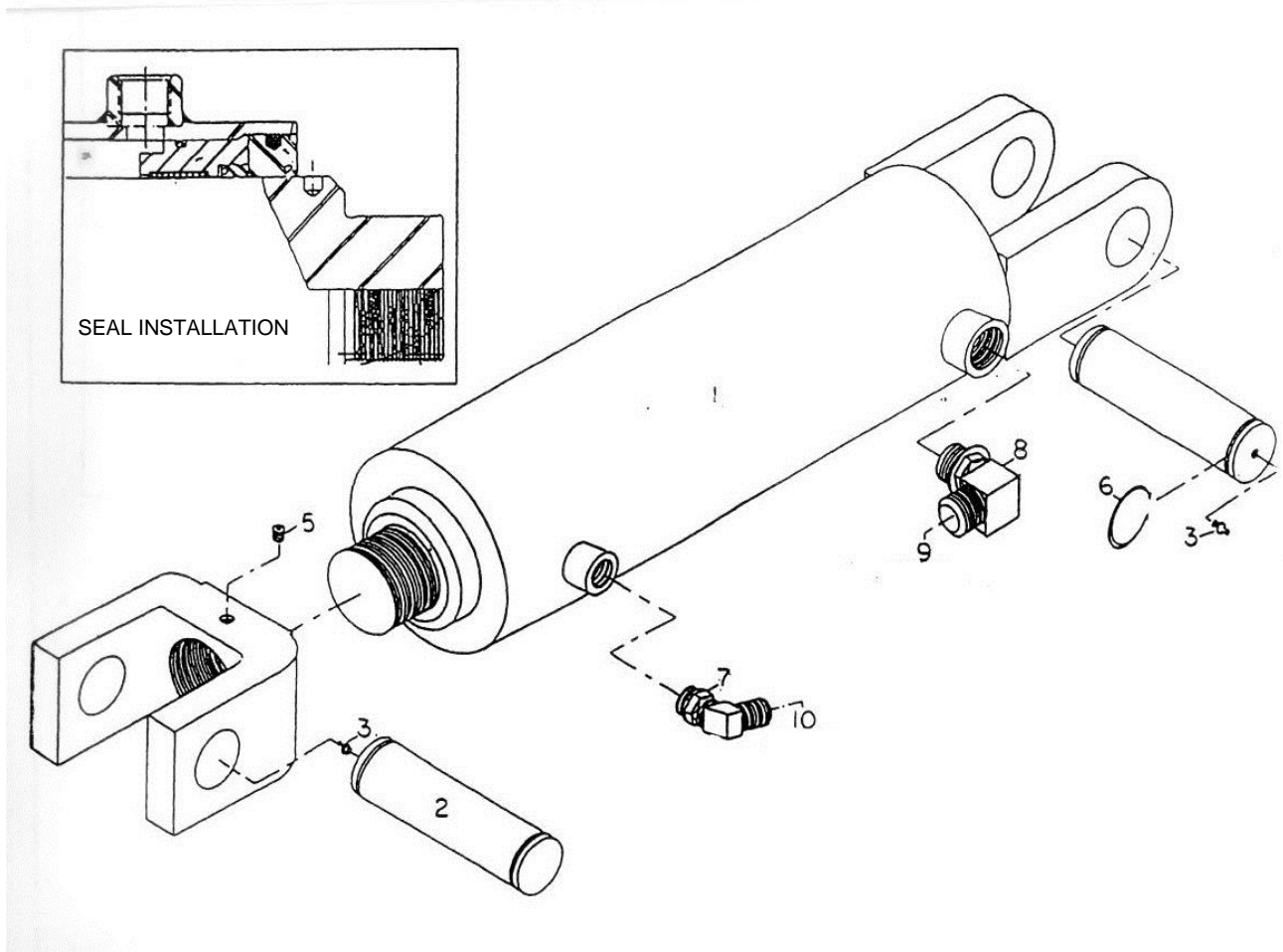

## FOOT SWITCH ASSEMBLY

PART NUMBER 0231628

Figure And Index No.	Part Number	Description	Qty.
1	0531655	Foot Switch	1
2	0531636	Cord Grip	1
3	0531637	16 - 4 SEO Cord (sold by the foot)	6 ft
4	0531617	4 Pole Plug	1

**NOTE:** Limit Switches in Foot Pedal are not a stock item, but can be obtained.

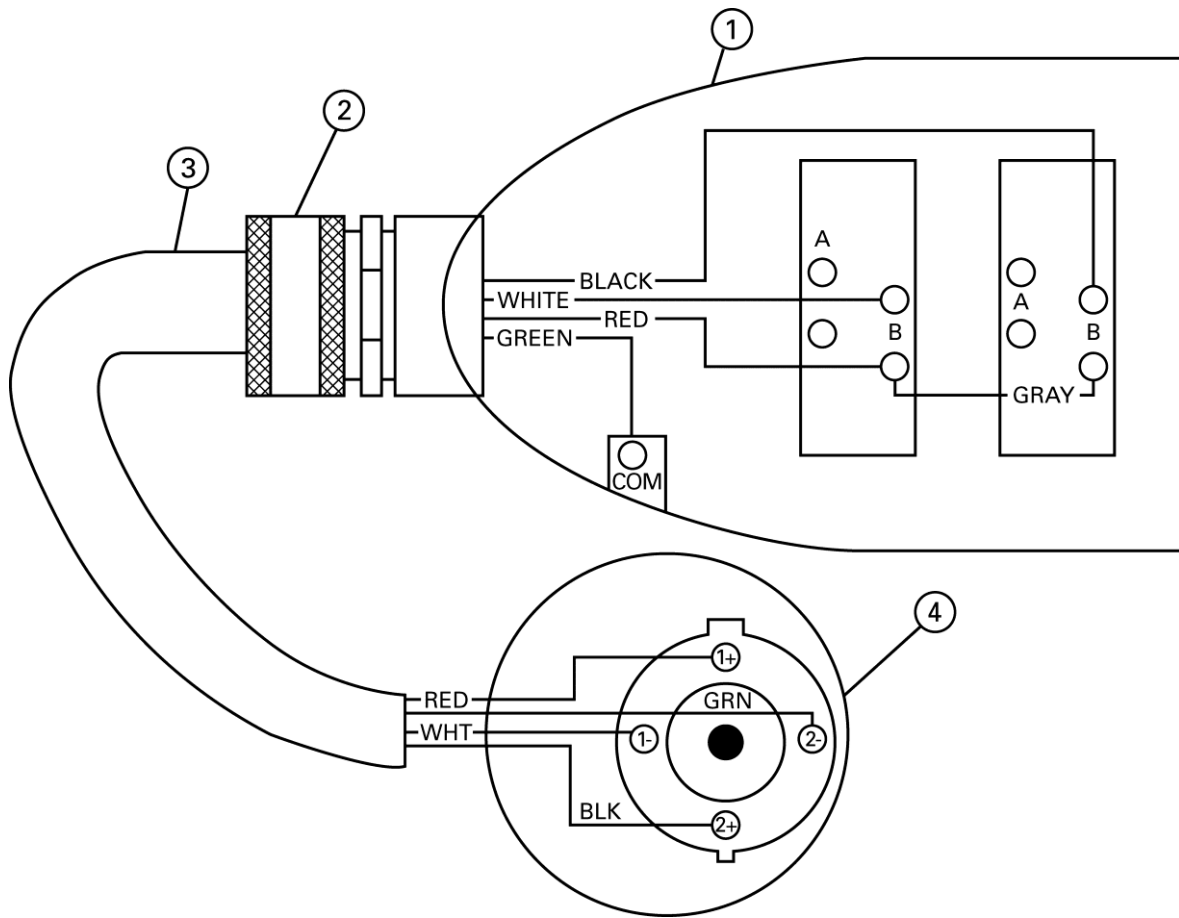



## P-90 KNIVES

Index No.	Part Number	Description	Qty.
	0250250	14.625 Shear Knives	2
	2402631	1/2" Rd Bar Knife - Short	1
	0240263	1/2" Rd Bar Knife - Tall	1
	2402641	5/8" Rd Bar Knife - Short	1
	0240264	5/8" Rd Bar Knife - Tall	1
	2402521	3/4" Rd Bar Knife - Short	1
	0240252	3/4" Rd Bar Knife - Tall	1
	2402531	7/8" Rd Bar Knife - Short	1
	0240253	7/8" Rd Bar Knife - Tall	1
	2402541	1" Rd Bar Knife - Short	1
	0240254	1" Rd Bar Knife - Tall	1
	2402551	1-1/8" Rd Bar Knife - Short	1
	0240255	1-1/8" Rd Bar Knife - Tall	1
	2402561	1-1/4" Rd Bar Knife - Short	1
	0240256	1-1/4" Rd Bar Knife - Tall	1
	2402571	1-3/8" Rd Bar Knife - Short	1
	0240257	1-3/8" Rd Bar Knife - Tall	1
	2402581	1-1/2" Rd Bar Knife - Short	1
	0240258	1-1/2" Rd Bar Knife - Tall	1
	2402591	1-5/8" Rd Bar Knife - Short	1
	0240259	1-5/8" Rd Bar Knife - Tall	1
	2402601	1-3/4" Rd Bar Knife - Short	1
	0240260	1-3/4" Rd Bar Knife - Tall	1
	2402611	1-7/8" Rd Bar Knife - Short	1
	0240261	1-7/8" Rd Bar Knife - Tall	1
	2402621	2" Rd Bar Knife - Short	1
	0240262	2" Rd Bar Knife - Tall	1
	2402821	1/2" Sq Bar Knife - Short	1
	0240282	1/2" Sq Bar Knife - Tall	1
	2402831	5/8" Sq Bar Knife - Short	1
	0240283	5/8" Sq Bar Knife - Tall	1
	2402841	3/4" Sq Bar Knife - Short	1
	0240284	3/4" Sq Bar Knife - Tall	1
	2402851	7/8" Sq Bar Knife - Short	1
	0240285	7/8" Sq Bar Knife - Tall	1
	2402861	1" Sq Bar Knife - Short	1

## P-90 KNIVES – Continued

Index No.	Part Number	Description	Qty.
	0240286	1" Sq Bar Knife - Tall	1
	2402871	1-1/8" Sq Bar Knife - Short	1
	0240287	1-1/8" Sq Bar Knife - Tall	1
	2402881	1-1/4" Sq Bar Knife - Short	1
	0240288	1-1/4" Sq Bar Knife - Tall	1
	2402891	1-3/8" Sq Bar Knife - Short	1
	0240289	1-3/8" Sq Bar Knife - Tall	1
	0240270	Round Bar Blank	1
	0250274	Lower Angle Knives	2
	0250273	Upper Angle Knife	1
	0250278	Lower Coper Knives	3
	0250277	Upper Coper Knife	1
	0531120	1/2" x 2-1/4" SHCS Upper Shear Knife	7
	0541100	1/2" x 2-3/4" SHCS Lower Shear & Angle Knives	13
	0531069	7/16" x 1-1/2" SHCS, Upper Coper	6
	0531330	Woodruff Key, Upper Coper	2
	0531071	7/16" x 2" SHCS Lower Coper Side Knives	6
	0551140	7/16" x 2-3/4" SHCS Lower Coper End Knife	3

DATE	LUBRICATION	KNIFE & TABLE BOLTS	MACHINE & CABINET BOLTS	HYDRAULIC CONNECTIONS	OIL LEVEL AND / OR CHANGE	OIL FILTER	KNIFE EDGES	REMARKS

## Piranha Optional Tooling and Attachments

\*\*\*Additional Options Shown on Inside of Front Cover\*\*\*

*Enhance your Piranha's versatility!*

### Pressbrake Tooling Holders

- Allows you to use pressbrake punches and dies in your ironworker for higher precision bending.



### Roller Feed Tables

- Available in 5' lengths.
- Includes rollers for angle and flat bar sections.
- 20" wide flat rollers and 6" angles.



### Channel Shear

- Attaches to the punch end of the machine.
- Removes a 1/2" slug for each cut.
- Slug must be slid out the front of the channel shear after each cut.
- A pinned slide block is adjusted to accommodate different widths of channel.



### Channel Die Block

- Enables you to punch into the legs of channel and other structural shapes.
- Mounts in place of your standard die block.
- Still utilizes your urethane punch attachment.
- Can be used in conjunction with offset dies to punch very near to the web of your material.



**MegaFab™**