

Process Unit Foaming Troubleshooting, Consulting and Testing

Nexo Solutions has most comprehensive protocols for foam troubleshooting and root-cause analysis. Foaming in many processing units can have several origins and onsite testing is one of the most effective ways to determine the various factors involved in foaming events.

Foaming Troubleshooting & Technical Services

- Process unit equipment design reviews
- Process and equipment operational evaluations
- Process unit consulting & foam minimization
- Process simulations & setpoint reviews
- Solvent foam testing (multiple locations)
- Feed gas slipstream testing for contaminant ingress
- Infrared imaging for budge temperature determination
- Filter and coalescer performance reviews
- Process unit audits and reviews
- Process solvent carryover verification
- Antifoam program evaluation
- Antifoam performance testing
- Process solvent analysis and foaming testing
- Foaming precursor analysis
- Foaming mitigation procedures

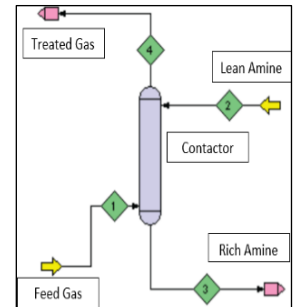

Supplies Evaluations

- Antifoam screening
- Corrosion inhibitors testing
- Iron sulfide (FeS) scale inhibitors testing
- Activated carbon verification
- Filter chemical compatibility reviews
- New amine foam testing
- Make up water testing

Others Products & Services

- Feed gas water wash systems
- Amine Unit technical seminars
- Lean and rich amine loading probes

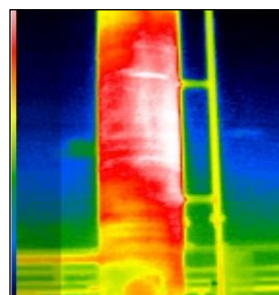

For additional information on our capabilities, contact us today via telephone, email or visit our website.