

# WVQHA

## All Rookie & Novice Youth/Novice Amateur Horsemanship

Show Date: July 23 - 24, 2020

w w w . H o r s e S h o w P a t t e r n s . c o m

w w w . H o r s e S h o w P a t t e r n s . c o m

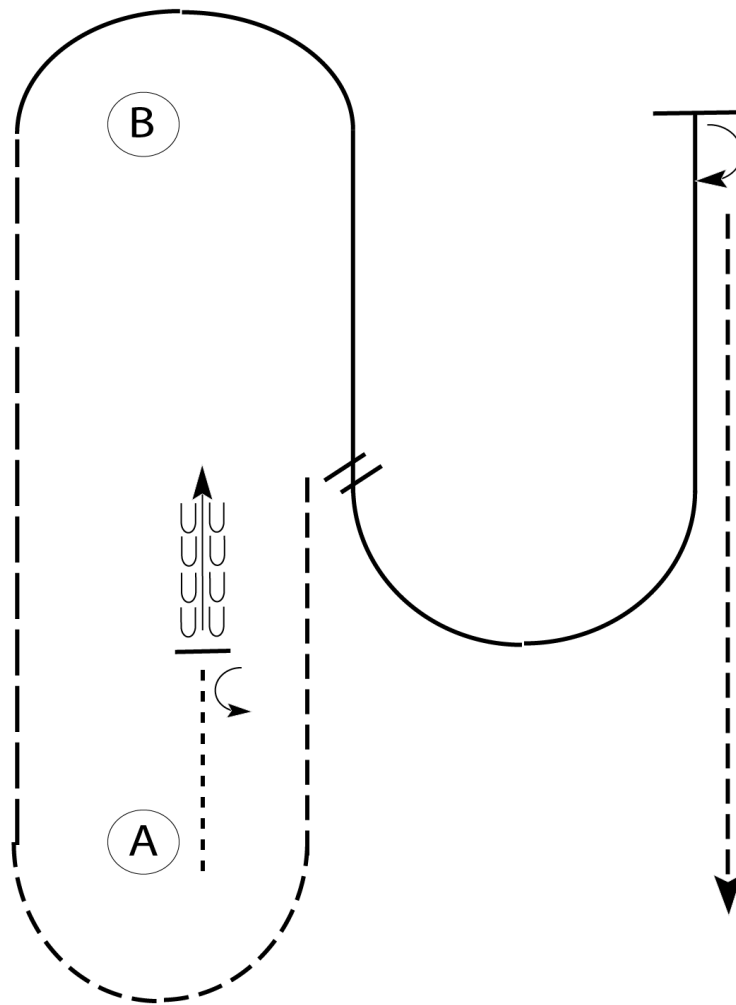

Be ready at A.

1. Walk approximately two horse lengths forward.  
Stop and perform a 1/2 turn left.
2. Back approximately two horse lengths then jog to and around A.
3. Extend the jog to B.
4. Right lead lope around B and halfway to A.
5. Perform a simple lead change and lope a half circle until even with B.
6. Stop and perform a 180 degree turn to the right and jog to finish.

Walk	-----
Jog	- - - - -
Extended Jog	— — — —
Lope	
Lead Change	⋈
Back	← ⊞ ⊞ ⊞ ⊞
Marker	⊙ B

[WH/1-118]

Pattern Provided by:

# WVQHA

## Small Fry Showmanship

Show Date: July 23 - 24, 2020

w w w . H o r s e S h o w P a t t e r n s . c o m

w w w . H o r s e S h o w P a t t e r n s . c o m

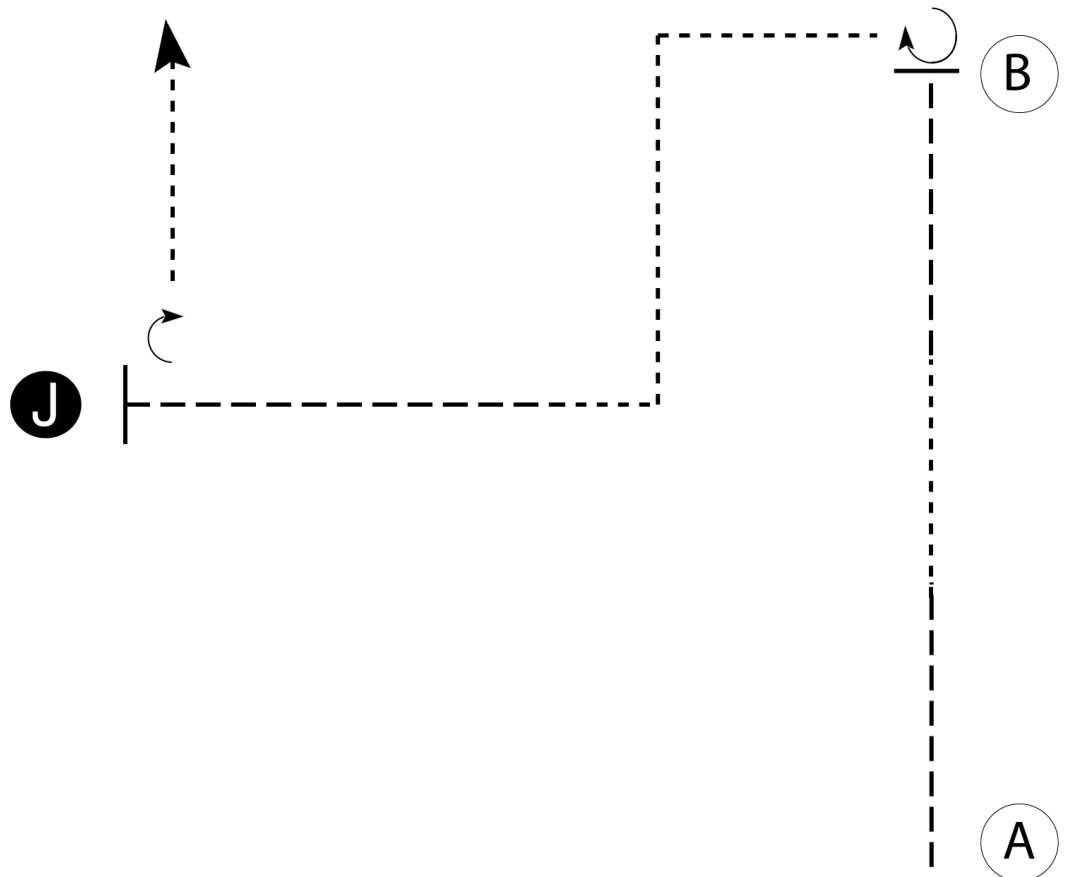

Be ready at A.

1. Trot 1/3 of the line, then walk 1/3 of the line then trot the final 1/3 of the line.
2. Stop with horse's hip even with B.
3. Perform a 3/4 turn.
4. Walk two square corners as shown then trot to judge.
5. Stop and set up at Judge.
6. Inspection.
7. When dismissed, perform a 1/4 turn and walk to exit.

Walk	-----
Trot	- - - - -
Back	← ⊃ ⊃ ⊃ ⊃
Marker	⊙ B
Judge	● J

[S/WT-119]

Pattern Provided by:

# WVQHA

## Youth/Amateur & Select Showmanship

Show Date: July 23 - 24, 2020

w w w . H o r s e S h o w P a t t e r n s . c o m

w w w . H o r s e S h o w P a t t e r n s . c o m

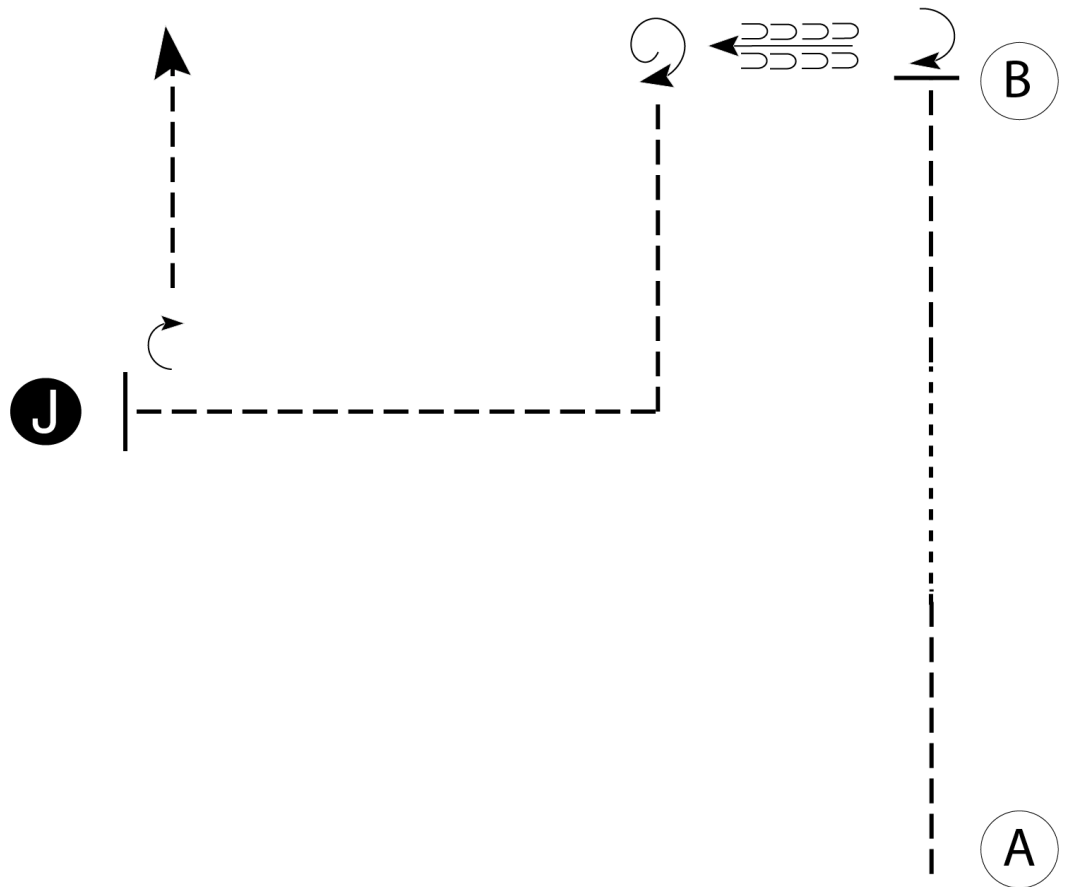

Be ready at A.

1. Trot 1/3 of the line, then walk 1/3 of the line then trot the final 1/3 of the line.
2. Stop with horse's hip even with B then perform a 1/4 turn.
3. Back 2 horse lengths then perform a 1 1/4 turn.
4. Trot to judge as shown.
5. Stop and set up at Judge.
6. Inspection.
7. When dismissed, perform a 1/4 turn and trot to exit.

Walk -----  
Trot - - - - -  
Back ← ⊃ ⊃ ⊃  
Marker (B)  
Judge (J)

[S/2-119]

Pattern Provided by:

# WVQHA

## All Rookie & Novice Youth/Novice Amateur Showmanship

Show Date: July 23 - 24, 2020

www.HorseShowPatterns.com

www.HorseShowPatterns.com

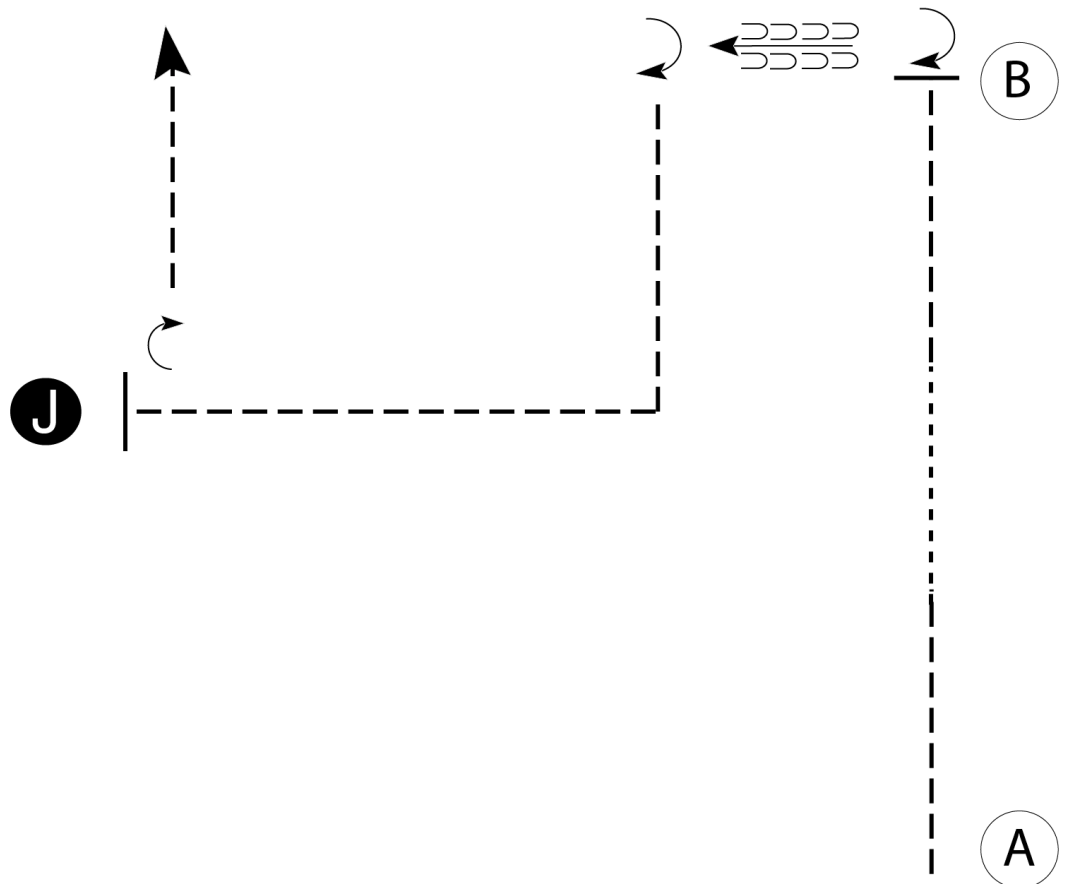

Be ready at A.

1. Trot 1/3 of the line, then walk 1/3 of the line then trot the final 1/3 of the line.
2. Stop with horse's hip even with B then perform a 1/4 turn.
3. Back 2 horse lengths then perform a 1/4 turn.
4. Trot to judge as shown.
5. Stop and set up at Judge.
6. Inspection.
7. When dismissed, perform a 1/4 turn and trot to exit.

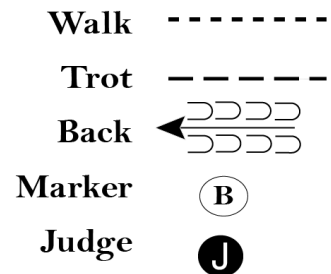

[S/1-119]

Pattern Provided by:

# WVQHA

## Youth/Amateur & Select Equitation

Show Date: July 23 - 24, 2020

W W W . H O R S E S H O W P A T T E R N S . C O M

W W W . H O R S E S H O W P A T T E R N S . C O M

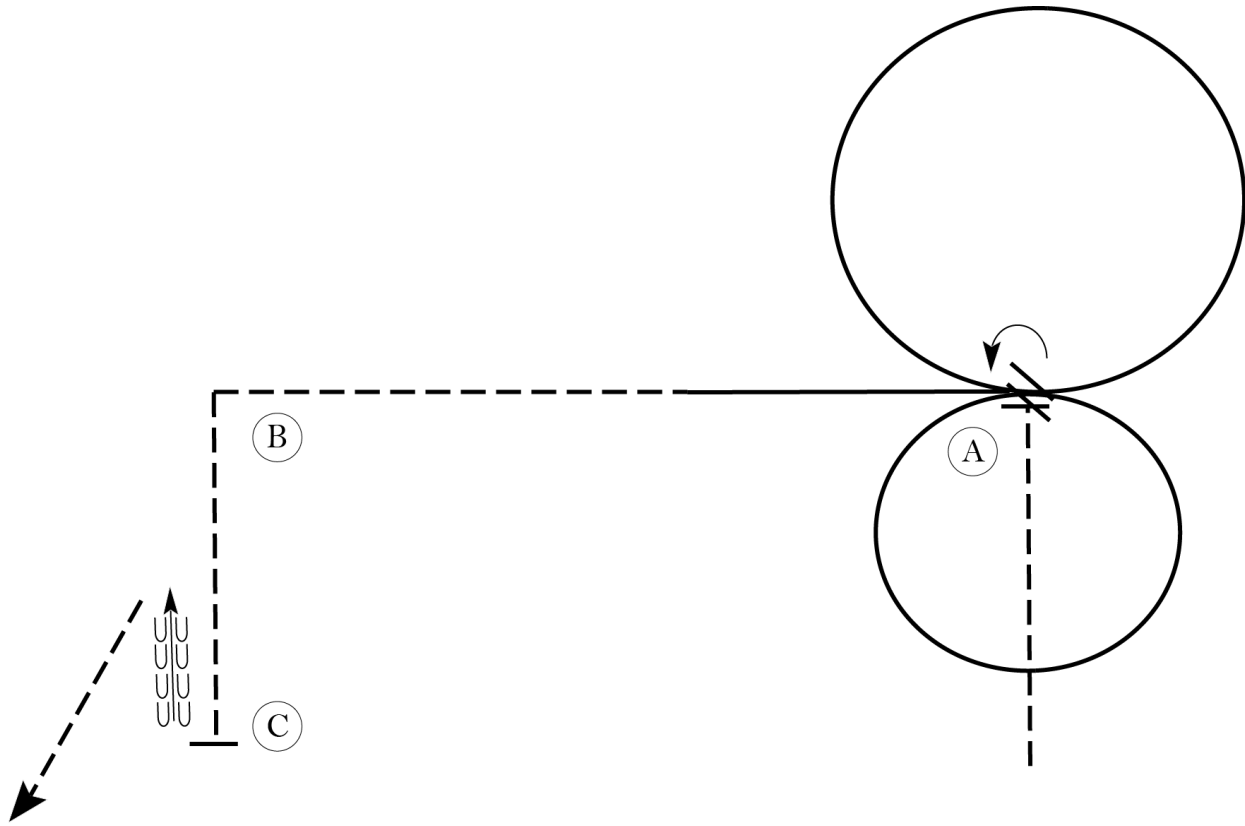

1. Trot on the left diagonal past A.
2. Stop and perform a 90 degree turn on the forehand to the left.
3. Canter a large circle to the right on the right lead.
4. Perform a simple lead change.
5. Canter a smaller circle to the left on the left lead and continue toward B.
6. Halfway to B, break to a sitting trot.
7. As you pass B, pick up the right diagonal and continue to C.
8. Stop at C and back one horse length and exit at a trot.

Follow the instructions of your ring steward.

Walk	-----
Trot	- - - - -
Extended Trot	-----
Canter	—————
Leg Yield	
Lead Change	↘ ↙
Back	← ← ← ← ←
Marker	(B)
Sidepass	← ← ← ← ←
Hand Gallop	—————

[HSE/2-78]

Pattern Provided by:

# WVQHA

## W/T Horsemanship

Show Date: July 23 - 24, 2020

w w w . H o r s e S h o w P a t t e r n s . c o m

w w w . H o r s e S h o w P a t t e r n s . c o m

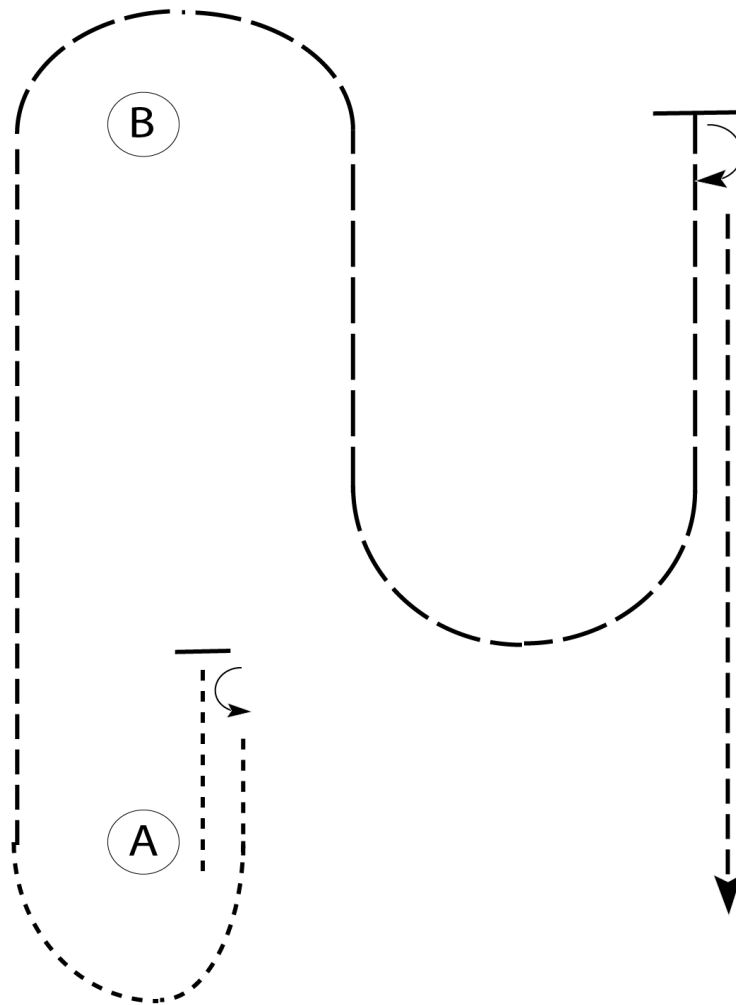

Be ready at A.

1. Walk approximately two horse lengths forward.  
Stop and perform a 1/2 turn left.
2. Walk to and around A.
3. Jog to B.
4. Extend the jog as shown until even with B.  
until even with B.
5. Stop and perform a 180 degree turn to the  
right and jog to finish.

Walk	-----
Jog	- - - - -
Extended Jog	— — — —
Lope	
Lead Change	— / —
Back	← ← ← ←
Marker	ⓑ

[WH/WT-118]

Pattern Provided by:

# WVQHA

## Youth/Amateur & Select Horsemanship

Show Date: July 23 - 24, 2020

www.HorseShowPatterns.com

www.HorseShowPatterns.com

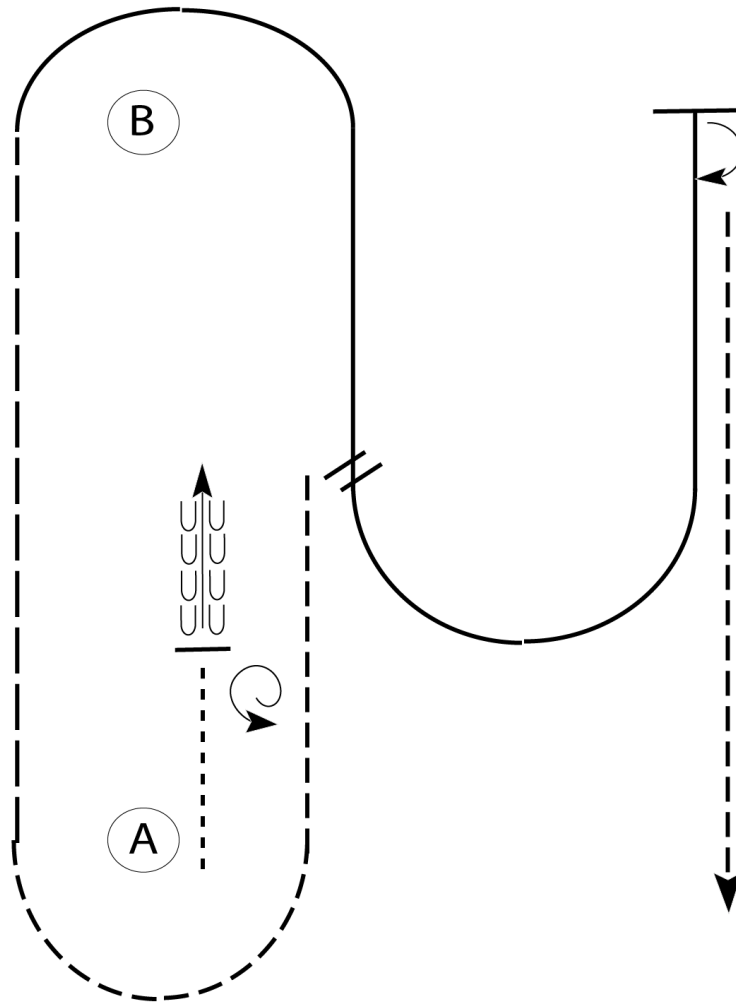

Be ready at A.

1. Walk approximately two horse lengths forward.  
Stop and perform a 1 1/2 turn left.
2. Back approximately two horse lengths then jog to and around A.
3. Extend the jog to B.
4. Right lead lope around B and halfway to A.
5. Perform a simple lead change and lope a half circle until even with B.
6. Stop and perform a 180 degree turn to the right and jog to finish.

Walk	-----
Jog	- - - - -
Extended Jog	— — — —
Lope	
Lead Change	⋈
Back	← ← ← ←
Marker	(B)

[WH/2-118]

Pattern Provided by:





# WVQHA

## all Level 1 Western Riding

Show Date: July 23 - 24, 2020

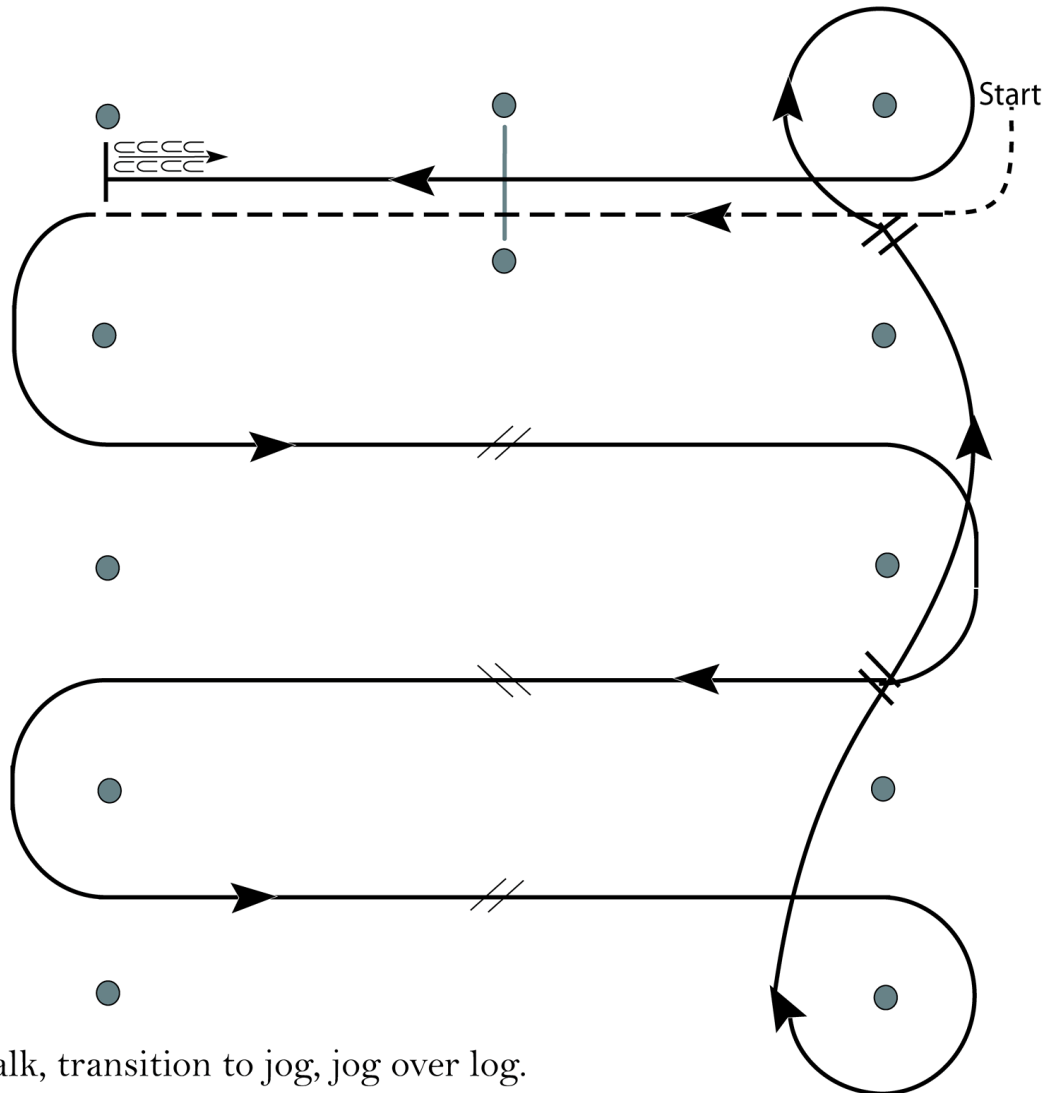

1. Walk, transition to jog, jog over log.
2. Transition to left lead lope.
3. First crossing change.
4. Second crossing change.
5. Third crossing change.
6. Circle and first line change.
7. Second line change and circle.
8. Lope log.
9. Stop and back.

[WR/GP-2]

Pattern Provided by:

# WVQHA

## All Reining

Show Date: July 23 - 24, 2020

### REINING PATTERN 7

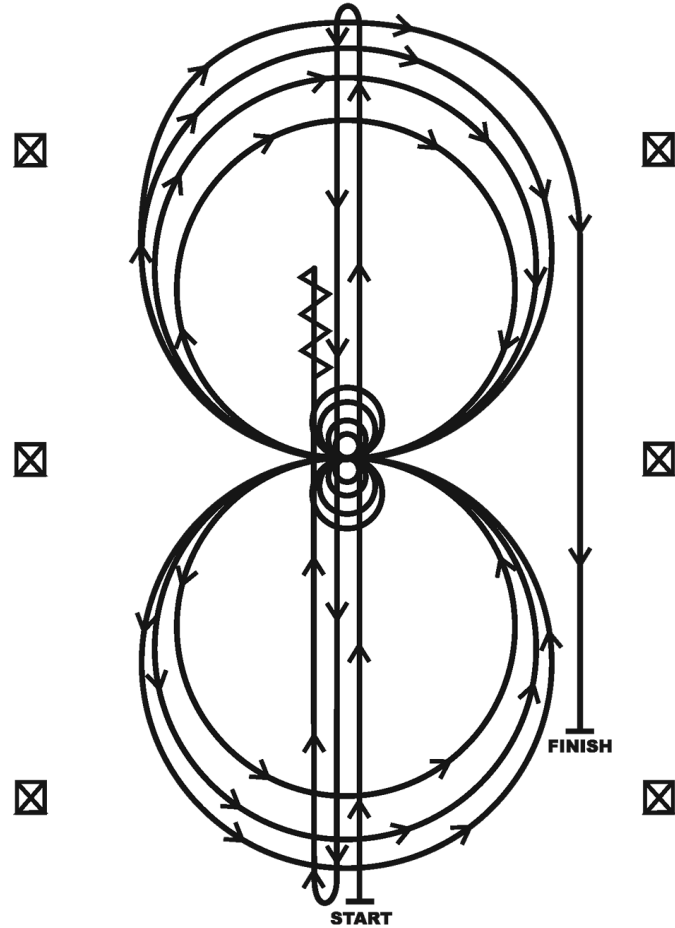

1. Run at speed to the far end of the arena past the end marker and do a left rollback—no hesitation.
2. Run to the opposite end of the arena past the end marker and do a right rollback—no hesitation.
3. Run past the center marker and do a sliding stop. Back up to the center of the arena or at least ten feet (three meters). Hesitate.
4. Complete four spins to the right. Hesitate.
5. Complete four and one-quarter spins to the left so that horse is facing left wall or fence. Hesitate.
6. Beginning on the right lead, complete three circles to the right: the first two circles large fast; the third circle small and slow. Change leads at the center of the arena.
7. Complete three circles to the left: the first two circles large fast; the third circle small and slow. Change leads at the center of the arena.
8. Begin a large circle to the right but do not close this circle. Run straight down the right side of the arena past the center marker and do a sliding stop at least twenty feet (six meters) from the wall or fence. Hesitate to demonstrate completion of the pattern.

[R/AQHAP-7]

Pattern Provided by:

# WVQHA

## All Rookie & Novice Youth/Novice Amateur Equitation

Show Date: July 23 - 24, 2020

w w w . H o r s e S h o w P a t t e r n s . c o m

w w w . H o r s e S h o w P a t t e r n s . c o m

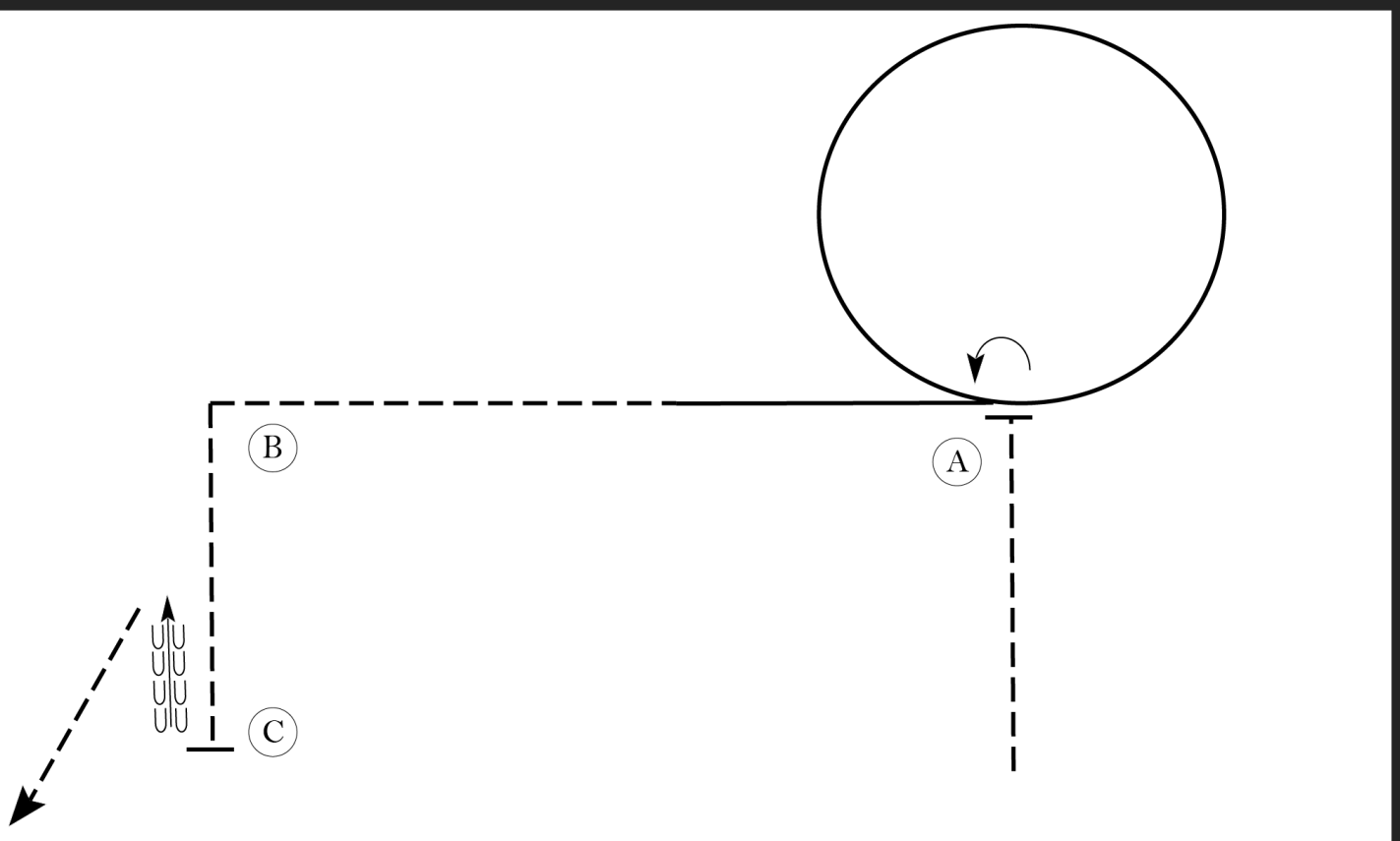

1. Trot on the left diagonal past A.
2. Stop and perform a 90 degree turn on the forehand to the left.
3. Canter a large circle to the right on the right lead.
4. Halfway to B, break to a sitting trot.
5. As you pass B, pick up the right diagonal and continue to C.
6. Stop at C and back one horse length and exit at a trot.

Follow the instructions of your ring steward.

Walk	-----
Trot	- - - - -
Extended Trot	-----
Canter	-----
Leg Yield	
Lead Change	↘
Back	←←←←←
Marker	(B)
Sidepass	←←←←←
Hand Gallop	-----

[HSE/1-78]

Pattern Provided by:

# WVQHA

## W/T Equitation

Show Date: July 23 - 24, 2020

w w w . H o r s e S h o w P a t t e r n s . c o m

w w w . H o r s e S h o w P a t t e r n s . c o m

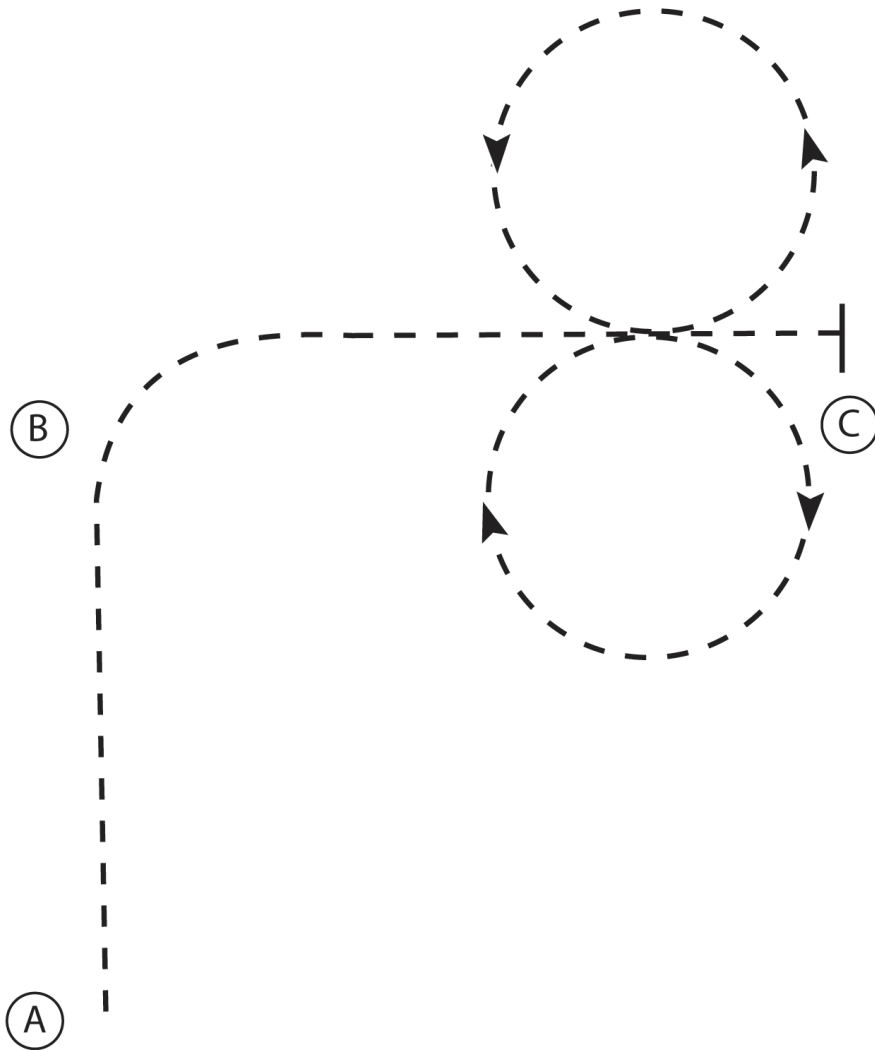

1. Sitting trot A to B
2. At B posting trot towards C
3. Before C posting trot circle to the right followed by a posting trot circle to the left, continue to C
4. Stop at C

Walk	.....
Trot	-----
Extended Trot	-----
Canter	—————
Leg Yield	
Lead Change	↘
Back	←←←←←
Marker	(B)
Sidepass	←-----←

Pattern Provided by:

[HSE/WT-7]