

DREYER

MODEL JE ELECTRIC CONCRETE VIBRATOR INSTRUCTION MANUAL

SAFETY / OPERATION / ASSEMBLY
MAINTENANCE / PARTS LIST

PROPER USE AND MAINTENANCE OF THIS RUGGED HI-PERFORMANCE TOOL WILL PAY OFF
IN FREEDOM FROM BREAKDOWNS AND COSTLY REPAIRS / PLEASE READ THOROUGHLY

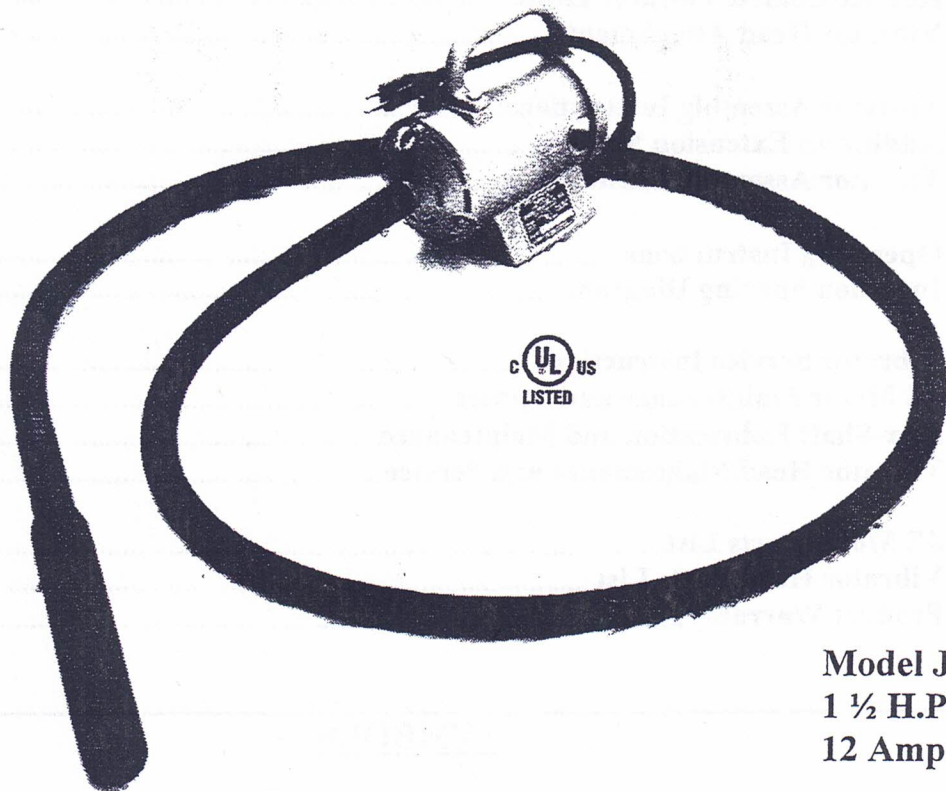

Model JE
1 ½ H.P.
12 Amps

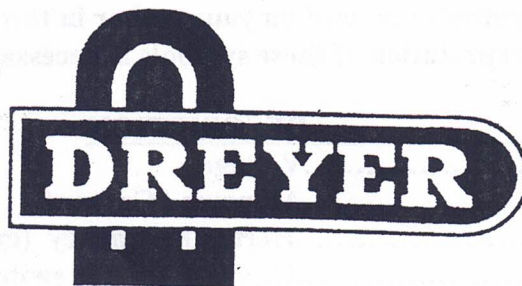



TABLE OF CONTENTS

General Power Tool Safety Warnings.....	2-3
Concrete Vibrator Safety Warnings.....	4
Component Descriptions.....	5
JE Electric Motor Specifications.....	5
JE Electric Motor Information / Grounding Instructions.....	6
Extension Cord Limitations.....	6
JE Flex-Shaft Information.....	6
Standard Shaft Information.....	6
Extension Shaft Information.....	6
Flex-Shaft List / Part #'s by Length.....	7
JE Vibrator Head Information.....	7
Vibrator Head Specifications.....	7
Rubber Coated Vibrator Heads.....	8
Vibrator Head Attachments.....	8
Vibrator Assembly Instructions.....	9
Adding an Extension Shaft.....	9
Vibrator Assembly Illustrations.....	10
Operating Instructions.....	11-12
Insertion Spacing Diagram.....	12
Vibrator Service Instructions.....	13-14
JE Motor Maintenance and Service.....	13
Flex-Shaft Lubrication and Maintenance.....	13
Vibrator Head Maintenance and Service.....	14
JE Motor Parts List.....	15-16
Vibrator Head Parts List.....	17-18
Product Warranty.....	8

SYMBOLS

IMPORTANT: The following symbols are used on your tool or in this manual. Please study them and learn their meaning. Proper interpretation of these symbols is necessary to understand the tool.

<u>SYMBOL</u>	<u>DESCRIPTION</u>
V.....	Voltage
A.....	Amperes / Current
Hz.....	Hertz / Frequency (cycle per second)
I / O.....	On / Off (motor switch)
IPX4.....	Moisture Protection Rating
	Earthing / Grounding Terminal

GENERAL POWER TOOL SAFETY WARNINGS

WARNING! READ ALL SAFETY WARNINGS AND INSTRUCTIONS:
FAILURE TO FOLLOW THE WARNINGS AND INSTRUCTIONS MAY RESULT IN
ELECTRIC SHOCK, FIRE AND/OR SERIOUS INJURY.

SAVE ALL WARNINGS AND INSTRUCTIONS FOR FUTURE REFERENCE

1. Work Area Safety

- A. **Keep work area clean and well lit.** Cluttered or dark areas invite accidents.
- B. **Do not operate power tools in explosive atmospheres, such as in the presence of flammable liquids, gases or dust.** Power tools create sparks, which may ignite the dust or fumes.
- C. **Keep children and bystanders away while operating a power tool.** Distractions can cause you to lose control.

2. Electrical Safety

- A. **Power tool plugs must match the outlet. Grounded tools must be plugged into an outlet properly installed and grounded in accordance with all codes and ordinances. Never remove the grounding prong or modify the plug in any way. Do not use any adaptor plugs with earthed (grounded) power tools. Check with a qualified electrician if you are in doubt as to whether the outlet is properly grounded.** Unmodified plugs and matching outlets will reduce the risk of electric shock. If the tools should electrically malfunction or break down, grounding provides a low resistance path to carry electricity away from the user.
- B. **Avoid body contact with earthed or grounded surfaces such as pipes, radiators, ranges and refrigerators.** There is an increased risk of electric shock if your body is earthed or grounded.
- C. **Do not expose power tools to rain or wet conditions.** Water entering a power tool will increase the risk of electric shock.
- D. **Do not abuse the cord. Never use the cord for carrying, pulling or unplugging the power tool. Keep cord away from heat, oil, sharp edges or moving parts. Replace damaged cords immediately.** Damaged or entangled cords increase the risk of electric shock.
- E. **When operating a power tool outdoors, use an extension cord suitable for outdoor use.** Use of a cord suitable for outdoor use reduces the risk of electric shock.
- F. **If operating a power tool in a damp location is unavoidable, use a earth leakage circuit breaker (ELCB) protected supply.** Use on an ELCB reduces the risk of electric shock.

3. Personal Safety

- A. **Stay alert, watch what you are doing and use common sense when operating a power tool. Do not use a power tool while you are tired or under the influence of drugs, alcohol or medication.** A moment of inattention while operating power tools may result in serious personal injury.
- B. **Use personal protective equipment. Always wear eye protection.** Protective equipment such as dust mask, non-skid safety shoes, hard hat, or hearing protection used for appropriate conditions will reduce personal injuries.

- C. **Prevent unintentional starting. Ensure the switch is in the off-position before connecting to power source and/or battery pack, picking up or carrying the tool.** Carrying power tools with your finger on the switch or plugging in power tools that have the switch on invites accidents.
- D. **Remove any adjusting key or wrench before turning the power tool on.** A wrench or a key left attached to a rotating part of the power tool may result in personal injury.
- E. **Do not overreach. Keep proper footing and balance at all times.** This enables better control of the power tool in unexpected situations.
- F. **Dress properly. Do not wear loose clothing or jewelry. Contain long hair. Keep your hair, clothing and gloves away from moving parts.** Loose clothes, jewelry or long hair can be caught in moving parts.
- G. **If devices are provided for the connection of dust extraction and collection facilities, ensure these are connected and properly used.** Use of these devices can reduce dust-related hazards.

4. Power Tool Use And Care

- A. **Do not force the power tool. Use the correct power tool for your application.** The correct power tool will do the job better and safer at the rate for which it was designed.
- B. **Do not use the power tool if the switch does not turn it on and off.** Any power tool that cannot be controlled with the switch is dangerous and must be repaired.
- C. **Disconnect the plug from the power source and/or the battery pack from the power tool before making any adjustments, changing accessories, or storing power tools.** Such preventive safety measures reduce the risk of starting the power tool accidentally.
- D. **Store idle power tools out of the reach of children and do not allow persons unfamiliar with the power tool or these instructions to operate the power tool.** Power tools are dangerous in the hands of untrained users.
- E. **Maintain power tools. Check for misalignment or binding of moving parts, breakage of parts and any other condition that may affect the power tools operation. If damaged, have the power tool repaired before use.** Many accidents are caused by poorly maintained power tools.
- F. **Keep cutting tools sharp and clean.** Properly maintained cutting tools with sharp cutting edges are less likely to bind and are easier to control.
- G. **Use the power tool, accessories and tool bits etc. in accordance with these instructions and in the manner intended for the particular type of power tool, taking into account the working conditions and the work to be performed.** Accessories that may be suitable for one tool, may become hazardous when used on another tool. Use of the power tool for operations different from those intended could result in a hazardous situation.

5. Service

- A. **Tool service must be performed only by qualified repair personnel.** Service or maintenance performed by unqualified personnel could result in a risk of injury.
- B. **When servicing a tool, use only identical replacement parts. Follow instructions in the Maintenance section of this manual.** Use of unauthorized parts or failure to follow Maintenance Instructions may create a risk of electric shock or injury.

COMPONENT DESCRIPTIONS

The DREYER MODEL JE is a 1 ½ HP electric internal flex-shaft type concrete vibrator engineered for maximum concrete consolidation, long life, and convenience of both operation and maintenance. This instruction manual is prepared to help you receive the best advantage of these features, by proper use and care. Flex-shaft lengths and vibrator head diameters are available in many different combinations depending upon the concrete application required. All components can be obtained individually or assembled into a complete vibrator.

AN ASSEMBLED CONCRETE VIBRATOR CONSISTS OF THREE MAJOR COMPONENTS:

1. ELECTRIC MOTOR
2. FLEXIBLE SHAFT
3. VIBRATOR HEAD

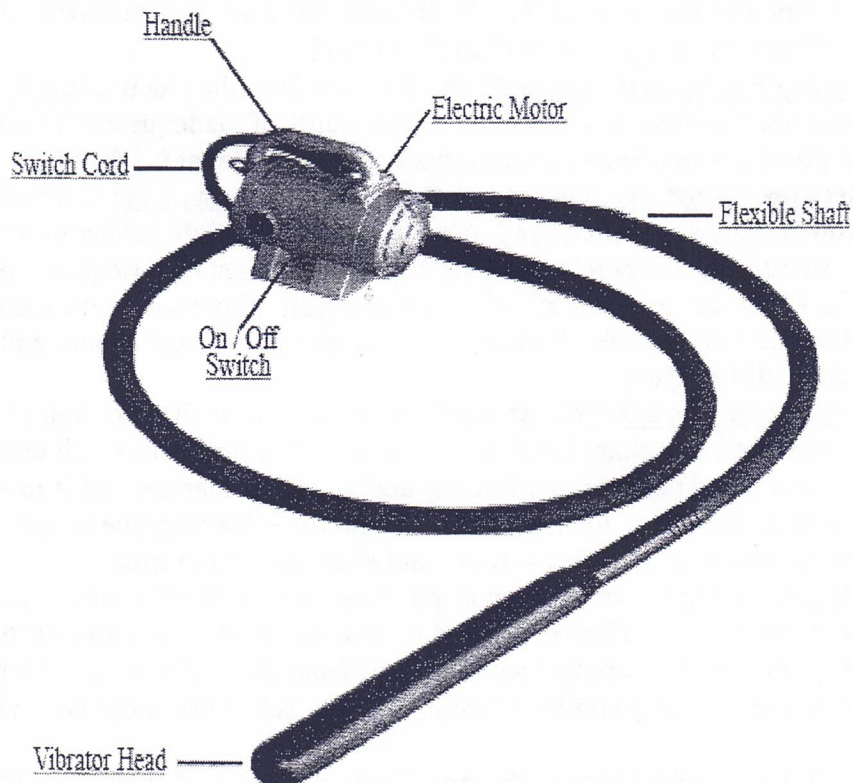

MODEL JE ELECTRIC MOTOR SPECIFICATIONS

Power Source – 110V Grounded
Universal Electric Motor
Horsepower – 1.5
Frequency – 60 CY
RPM – 11,000

Amperage - 12
Weight – 15 LBS.
Housing Material – Aluminum Alloy
Maximum Shaft Length – 20 FT.
Maximum Head Diameter – 1-3/4 “

CONCRETE VIBRATOR SAFETY WARNINGS

WARNING! : WHEN USING CONCRETE VIBRATORS, BASIC SAFETY PRECAUTIONS SHOULD ALWAYS BE FOLLOWED TO REDUCE THE RISK OF FIRE, ELECTRIC SHOCK AND PERSONAL INJURY.

READ ALL INSTRUCTIONS AND SAVE THEM FOR FUTURE REFERENCE

1. Know your concrete vibrator: Read Instruction Manual carefully. Learn its applications and limitations as well as the specific potential hazards peculiar to this type of tool to avoid operator injury or damage to your vibrator.

2. Grounding Instructions: This vibrator must be grounded while in use to protect the operator from electric shock. This tool is equipped with a 3-conductor cord and a 3-prong grounding type plug to fit the proper 110V grounding type receptacle. **CAUTION: Receptacle must be grounded.** If in doubt call a qualified electrician and have the receptacle checked for ground.

3. Use proper gauge size on extension cords: As the distance from the electric supply outlet increases, heavier gauge extensions are required. The use of extension cords of inadequate wire size causes a serious drop in voltage, loss in power, poor vibrator performance, and possible motor damage.

4. Use personal protection equipment when operating a concrete vibrator: Concrete tends to spatter when placed so eye protection is always required. Always wear water-tight rubber gloves and rubber boots when it is necessary to stand in wet concrete, not only to protect against electric shock but also to keep concrete from your skin. Clean out any concrete that gets into your gloves or boots and wash off skin that has been exposed to concrete immediately. Wear hard hats to protect against concrete placement equipment. **Failure to do so could result in injury.**

5. Don't abuse your concrete vibrator: Never use the electric cord or shaft to drag the vibrator. Avoid operating vibrator with the shaft in a sharp bend for a long period of time – this will create unnecessary core wear. Do not wedge vibrator head between reinforcing steel in such a manner that it restricts the movement of the head. This will shorten the life of the head bearings and tube. Never place motor in concrete. This will increase the risk of electric shock. Remember – water and electricity don't mix.

6. Maintain tool with care: Keep motor as clean as possible – especially the air slots on the front end bell and air vents behind rear motor cover. Please read and follow service instructions to properly assemble components. Lubricating service is recommended to the head and shaft after every 150 hours of service. This will extend the good performance and life of your vibrator. When idle store your vibrator in a clean dry place.

7. Inspect for damaged parts before using vibrator: Broken or cracked shafts should be replaced before damage is done to head and core. It is better to replace worn out head tubes, than to wait until concrete works in and ruins the entire head. Inspect electric cords, if damaged do not use the vibrator and have it repaired at an authorized service center. Inspect extension cords and replace if damaged.

8. Wet concrete acts as a coolant for the vibrator head: Never operate the vibrator head out of the concrete exceeding 1 minute to avoid overheating the grease seal. Head failure could damage the electric motor.

9. Make sure concrete formwork is secure: To prevent possible operator injury or costly blowouts caused by the weight of concrete and the force generated by the vibrator head.

10. Stay alert: Remember – you are the best safety device of this or any other power tool.

MODEL JE ELECTRIC MOTOR

WARNING! : THIS VIBRATOR MUST BE GROUNDED WHILE IN USE TO PROTECT THE OPERATOR FROM ELECTRIC SHOCK.

IMPORTANT GROUNDING INSTRUCTIONS: This tool is equipped with a 3-conductor cord and a 3-prong grounding type plug to fit the proper 110V grounding type receptacle. CAUTION: Receptacle must be grounded. If in doubt call a qualified electrician and have the receptacle checked for ground.

MODEL JE EXTENSION CORD LIMITATIONS

<u>EXTENSION CORD LENGTH</u>	<u>WIRE GAUGE REQUIRED</u>
<u>0 – 25 FT.</u>	<u>14 GA.</u>
<u>25 – 50 FT.</u>	<u>12 GA.</u>
<u>50 – 100 FT.</u>	<u>10 GA.</u>

THE DREYER JE VIBRATOR IS ACTIVATED WITH A RECESSED SWITCH ON THE LEFT SIDE OF THE ELECTRIC MOTOR THAT IS MARKED:

I / O - “ I ” for ON and “ O ” for OFF

MODEL JE STANDARD SHAFTS

The JE STANDARD SHAFT consists of an outer CASING (1-1/4” OD) and an inner drive CORE. The Casing is manufactured with a flexible flat spring covered by a steel braid that is molded together with a rubber/fabric exterior. The JE Standard Casing has female LEFT HAND THREADS on both ends. The JE Casing is reversible and either end is compatible to the motor or head. The JE Core is a flexible steel drive cable that has female RIGHT HAND THREADS on one end that make up to the electric motor drive tip and a hex drive on the other that inserts into the vibrator head. JE PENCIL SHAFTS* (13/16” OD) are also available.

WARNING: MAXIMUM JE SHAFT LENGTH – 20 FT. – Shaft Lengths Any Longer Can Electrically Damage The Motor.

MODEL JE EXTENSION SHAFTS

JE EXTENSION SHAFTS can be coupled with JE STANDARD SHAFTS to extend the overall working length of a vibrator up to the MAXIMUM WORKING LENGTH – 20 FT.

AN EXTENSION SHAFT WILL NOT WORK BY ITSELF and will only fit in combination between the Electric Motor and the Standard Shaft. Extension Shafts can be obtained in any requested length and can be utilized to create any two different overall lengths that may be required. **FOR EXAMPLE:** An 8 FT. Extension Shaft combined with a 12 FT. Standard Shaft will provide either a 20 FT. vibrator or a 12 FT. vibrator.

BOTH STANDARD SHAFTS AND EXTENSION SHAFTS CAN BE OBTAINED IN ANY LENGTH REQUIRED UP TO THE MAXIMUM WORKING LENGTH OF 20 FT.

JE STANDARD SHAFTS**JE PENCIL SHAFTS**

PART #	LENGTH	WEIGHT
J 1S	1 FOOT	3 LBS
J 2S	2 FOOT	4 LBS
J 3S	3 FOOT	5 LBS
J 4S	4 FOOT	6 LBS
J 5S	5 FOOT	7 LBS
J 6S	6 FOOT	8 LBS
J 7S	7 FOOT	9 LBS
J 8S	8 FOOT	10 LBS
J 9S	9 FOOT	11 LBS
J 10S	10 FOOT	12 LBS
J 11S	11 FOOT	13 LBS
J 12S	12 FOOT	14 LBS
J 13S	13 FOOT	15 LBS
J 14S	14 FOOT	16 LBS
J 15S	15 FOOT	17 LBS
J 16S	16 FOOT	18 LBS
J 17S	17 FOOT	19 LBS
J 18S	18 FOOT	20 LBS
J 19S	19 FOOT	21 LBS
J 20S	20 FOOT	22 LBS

PART #	LENGTH	WEIGHT
J 1SP	1 FOOT	.5 LBS
J 2SP	2 FOOT	1 LBS
J 3SP	3 FOOT	1.5 LBS
J 4SP	4 FOOT	2 LBS
J 5SP	5 FOOT	2.5 LBS
J 6SP	6 FOOT	3 LBS
J 7SP	7 FOOT	3.5 LBS
J 8SP	8 FOOT	4 LBS
J 9SP	9 FOOT	4.5 LBS
J 10SP	10 FOOT	5 LBS
J 11SP	11 FOOT	5.5 LBS
J 12SP	12 FOOT	6 LBS
J 13SP	13 FOOT	6.5 LBS
J 14SP	14 FOOT	7 LBS
J 15SP	15 FOOT	7.5 LBS
J 16SP	16 FOOT	8 LBS
J 17SP	17 FOOT	8.5 LBS
J 18SP	18 FOOT	9 LBS
J 19SP	19 FOOT	9.5 LBS
J 20SP	20 FOOT	10 LBS

MAXIMUM JE SHAFT LENGTH – 20 FT. All JE shafts have Left Hand Threads. Standard and extension shafts can be obtained in any length required. Add “X” to Part # - for extension shafts.

MODEL JE VIBRATOR HEADS

The VIBRATOR HEAD utilizes the high RPM of an eccentric weight to create the force and motion to consolidate concrete. The eccentric weight rotates upon high-speed bearings that are lubricated by DREYER HEAD OIL which produces a lubricating mist inside the head tube during operation. Different head sizes are interchangeable with all JE Standard Shafts, 1-1/4”OD. The 13/16” Pencil Heads fit only the 13/16”OD Pencil Shafts. JE heads have Left Hand Threads.

WARNING: MAXIMUM HEAD DIAMETER – 1-3/4” - In combination with the Model JE 1-1/2 HP motor - Do not use Dreyer’s 2-1/8” or 2-1/2” heads. These heads are designed for Model BE 2-1/2 HP motors and can electrically damage a Model JE motor.

JE VIBRATOR HEADS Are Available In Four Diameters: 13/16” / 1-1/8” / 1-3/8” / 1-3/4”.

JE VIBRATOR HEAD SPECIFICATIONS

DIAMETER	13/16”	1-1/8”	1-3/8”	1-3/4”
PART #	J131611	J11811	J13811	J13411
LENGTH	11”	11-1/4”	11-1/4”	13-1/4”
WEIGHT	1-1/4 lbs	2-1/2 lbs	3-1/2 lbs	6 lbs
VPM (Average/no load)	15,000	13,500	12,000	10,000
EFFECTIVE DIAMETER*	5” – 8”	6” – 10”	8” – 12”	9” – 18”

*The actual effective diameter of vibration varies with the concrete slump and aggregate size in the mixture. High slump concrete will have a larger effective diameter than low slump concrete.

JE RUBBER COATED VIBRATOR HEADS

To protect epoxy coated rebar from damage caused by the use of steel heads, rubber coated heads are required in most situations. Dreyer rubber coated heads can easily be recoated and rebuilt after the coating has worn away, at a reduced cost. Rubber coated heads can be obtained in three overall diameters (including the rubber coating) – 1-3/8" / 1-3/4" / 2-1/8".

JE VIBRATOR HEAD ATTACHMENTS

Dreyer standard style vibrator heads have a welded and permanent steel round tip. Also available, as an option, is a flat bottom vibrator head system that is engineered to accept several different attachments to cover various applications without changing the vibrator head.

REPLACEABLE STEEL TIPS (PART# – RST) – In certain severely extreme concrete applications such as with precast steel forms or concrete beam forms with prestressed strand, vibrator heads usually wear at or near the bottom of the head tube. The RST system allows the tip to be changed before the tube or the entire head needs to be replaced, extending the overall life of the vibrator head at a reduced cost.

RUBBER TIPS (PART# – RT) – Available to protect and preserve expensive concrete forms or finished concrete surfaces from the damage that may result from contact with standard steel tipped heads.

REBAR SHAKERS (PART# – RBS) – For concrete consolidation through the use of vertically placed rebar reinforcement extending from the top of wall forms including ICF applications. Rebar shakers can be obtained for any size of rebar.

PRODUCT WARRANTY

WARRANTY: DREYER VIBRATOR CO., INC. warrants its new product to be free from defects in workmanship and material for a period of one year from date of purchase. Performance of equipment is further warranted to be in accordance with stated ratings when properly installed and used under normal conditions of operation.

WARRANTY CLAIM PROCEDURE: Any new equipment that proves to be defective within the warranty period will, if returned to the factory with transportation charges prepaid, be repaired or replaced free of charge. If unit is repaired or replaced under warranty it will be returned freight prepaid. Before returning any material claimed defective to DREYER for inspection, written permission must be obtained from DREYER VIBRATOR CO., INC. and the defective part must be returned by an authorized DREYER distributor.

LIMITATIONS: DREYER VIBRATOR CO., INC. will not be responsible for any damage or losses, direct or indirect, arising from any cause whatsoever, nor for damage to the equipment caused by outside influences including improper voltage supply, lightning, careless handling or lack of proper maintenance, nor for labor, transportation or other charges incurred in the replacement or repair of defective parts. There are no warranties, expressed or implied, applicable to products except as expressly herein. DREYER will not be responsible for any statements that are made or published, written or oral, which are misleading or inconsistent with the facts as published in the literature or specifications furnished by DREYER.

This warranty supersedes any warranty not dated or bearing an earlier date. JUNE 1, 2009

VIBRATOR ASSEMBLY INSTRUCTIONS

SAFETY WARNING: DISCONNECT POWER SUPPLY TO THE ELECTRIC MOTOR FOR ALL ASSEMBLY PROCEDURES. FAILURE TO DO SO MAY RESULT IN PERSONAL INJURY OR EQUIPMENT DAMAGE.

IMPORTANT: All Dreyer shafts and heads have LEFT HAND THREADS. All threaded ends of the inner drive core have RIGHT HAND THREADS.

TO ASSEMBLE VIBRATOR HEAD TO SHAFT

Tools required – Pipe wrench and pipe vise (or two pipe wrenches).

1. Clamp the casing end of the shaft into a pipe vise. Push the hex drive of the core back into the casing. This will put the opposite threaded end of the core in position to connect to the motor.
 2. Screw on the vibrator head by hand using caution not to cross thread. Remember – LEFT HAND THREADS.
 3. To tighten up, grasp the head cone end of the head with a pipe wrench and apply at least 150 lbs. of torque. Use a metal file to remove any bite mark burrs left by the wrench.
CAUTION: Never place a pipe wrench, to tighten a vibrator head, in the middle of the head tube, to avoid warping the bearing surfaces or collapsing the tube. See Fig. 1.
-

TO ASSEMBLE SHAFT TO ELECTRIC MOTOR

Tools required – Two 5/16” open end wrenches.

1. To couple up the assembled head and shaft, first pull out the inner core a few inches. Using the 5/16” wrenches and the wrench slots provided, connect the threaded core end to the drive tip of the motor. Remember – RIGHT HAND THREADS. Tighten with only moderate torque. See Fig. 2.
 2. Slide the casing toward the female threads of the motor. If resistance is felt, use a 5/16” wrench on the slotted motor drive tip to slowly rotate the core while maintaining a gentle pull on the casing. The hex tip at the opposite end of the core will enter the eccentric weight drive inside of the head allowing the shaft and head assembly to be pulled into place and threaded to the motor. LEFT HAND THREADS.
-

TO ADD AN EXTENSION SHAFT

Tools required – Two pipe wrenches and two 5/16” open end wrenches.

Extension shafts have one male casing end and one female casing end. The female end of the extension shaft attaches to the motor only. The standard shaft and head are then added to extend the length of the unit. When adding an extension shaft follow these steps:

1. Remove shaft and head as an assembled unit from the motor.
2. Pull out and couple the two inner cores with two 5/16” wrenches. Wrench slots are provided on the threaded core ends. See Fig. 3.
3. Connect the casings together and tighten with two pipe wrenches with at least 150 lbs. of torque. LEFT HAND THREADS. Use a file to remove any bite mark burrs left by the wrenches.
4. Connect the assembly of the two shafts and a head to the motor as described in the above section.

Figure 1
Proper Wrench Placement
To Assemble Vibrator Head

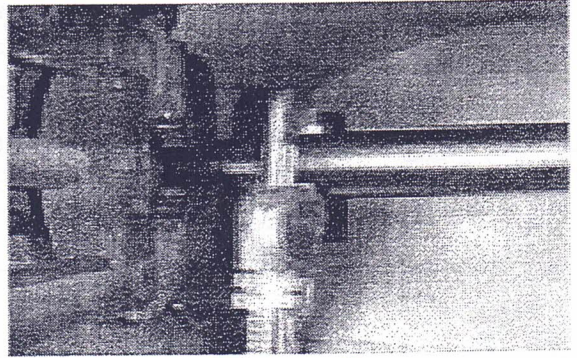

Figure 1

Figure 2
Making Up A Core To A JE Motor

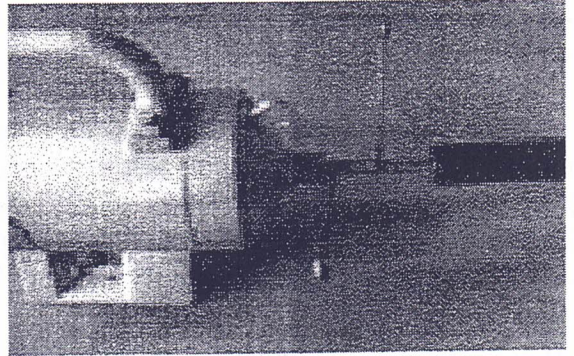

Figure 2

Figure 3
Making Up A Standard Shaft Core
To An Extension Shaft Core

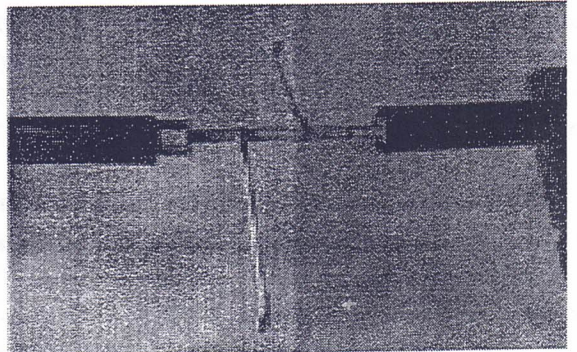

Figure 3

Figure 4
Greasing A Core

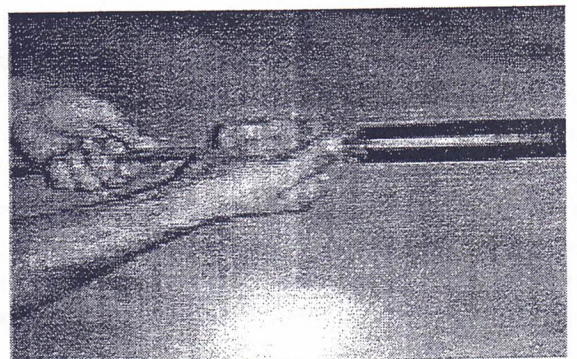

Figure 4

OPERATING INSTRUCTIONS

IMPORTANT: PROPER OPERATING TECHNIQUE IS EXTREMELY IMPORTANT AND SPECIAL ATTENTION MUST BE PAID TO THIS SECTION TO UTILIZE THE FULL BENEFITS OF THIS TOOL AND ACHIEVE MAXIMUM CONSOLIDATION OF THE CONCRETE BEING WORKED.

- 1. Vibrator operators must be properly trained and have a full understanding of the basic principles of how an internal vibrator works. Inside the vibrator head, an unbalanced weight called an eccentric is turned at a high RPM by a flex-shaft drive core attached to the motor. This causes the vibrator head to oscillate with an extreme centrifugal force and when immersed into freshly placed concrete creates a field of vibrating action.**
- 2. The purpose of this field of vibration is to consolidate concrete. The vibration causes the concrete to act and be manipulated as a liquid, by forcing out entrapped air, evenly dispersing the aggregate, and filling in the voids of tight spaces. This consolidation increases compressive strength and bond between concrete and rebar after the structure is cured. Concrete consolidation decreases water permeability, honeycombing, and loss of structural integrity due to entrapped air and aggregate segregation.**
- 3. It is important to choose the proper shaft length, head diameter and motor size for the concrete application at hand. The major determining factors include rebar spacing, depth, width or shape of forms and consideration must be given to the consistency of the concrete mix pertaining to concrete slump and aggregate size. Generally speaking, a large aggregate and a dry low slump concrete will require a larger diameter head and a more powerful motor than a high slump, small aggregate concrete mix. Head diameter is one factor that determines the size of the effective diameter of vibration in concrete. Approximate effective diameters per head size are listed on page 7 of this manual.**
- 4. To vibrate properly, it is best to insert a vibrator head vertically and rapidly to the bottom of the form or the last lift of concrete. A vibrator head moving downward will start to liquefy the concrete, but basically creates its own void at this point. The true process of vibration occurs during the lift upwards as the field of action around the vibrator head is pulled up slowly and methodically, forcing entrapped air from underneath aggregate and reinforcement, up the sides of the form and out of the concrete. It is important to make this lift slowly so that the void left behind by the vibrator head has time to refill within the field of action, leaving behind the consolidated concrete of the finished product.**
- 5. Good timing while lifting a vibrator head upward through the concrete is one of the most crucial technique skills required of a vibrator operator and determines the quality of the consolidation in the finished structure. If the timing of the pull is executed too fast, erratically, or inconsistently, zones of unconsolidated voids will be left behind in the concrete. For the vibrator operator, removing the vibrator head must be thought of as slowly chasing entrapped air upward one zone at a time with the lower zone blending into the one above as the vibrating field of action passes through. There are many factors involved with the proper amount of time for a vibrator to consolidate, but an average general rule is to pull up the vibrator head at a rate of 20 seconds for a 5 foot lift. Approximately 3 inches per second.**

6. It is important to pay special attention to the spacing between the insertions of the vibrator head. The field of action or the effective diameter around the head must always overlap the effective diameter from the previous insertion. The operator should perform the overlapped insertions in sections, being aware not to skip over any areas. Observe the surface of the concrete to determine the size of the effective diameter. Larger heads, more powerful motors and high-slump concrete will create a larger effective diameter. As a general rule, in most situations, the effective diameter is usually 8 times the vibrator's head diameter.

7. There are clues that help an operator judge when proper consolidation has taken place. The concrete surface will take on a sheen and large air bubbles will no longer escape. Listen to and feel the vibrator motor. The motor will change in pitch and tone, when consolidation has occurred. This change in action can actually be felt by the operator. These signs will indicate the right time to resume a lift in a wall or move the vibrator head to the next overlapped area of unvibrated concrete. Different consistencies of concrete mixes requires different vibrator operating techniques. Generally, a dryer low-slump concrete will have a smaller effective diameter and will take a longer period of time to properly consolidate.

8. If a vibrator head becomes wedged and stuck in reinforcement, turn the vibrator motor and shaft to the left while pulling. This will tighten the vibrator head while rolling and walking it out of the reinforcement. Vibrators are different from other tools because they can only be effective when the concrete is in a very short lived state of workability. Never start a concrete job without a spare vibrator on hand.

THREE TECHNIQUE RULES A VIBRATOR OPERATOR MUST OBSERVE:

1. Good timing while lifting a vibrator head.
2. Make sure to properly space head insertions to overlap radius of action.
3. Work the vibrator head vertically not sideways.

THREE SIGNS THAT CONCRETE HAS ACHIEVED PROPER CONSOLIDATION:

1. Concrete surface has leveled and taken on a sheen.
 2. Large air bubbles no longer escape the concrete.
 3. A change in the pitch, tone, and feel of the vibrator motor.
-

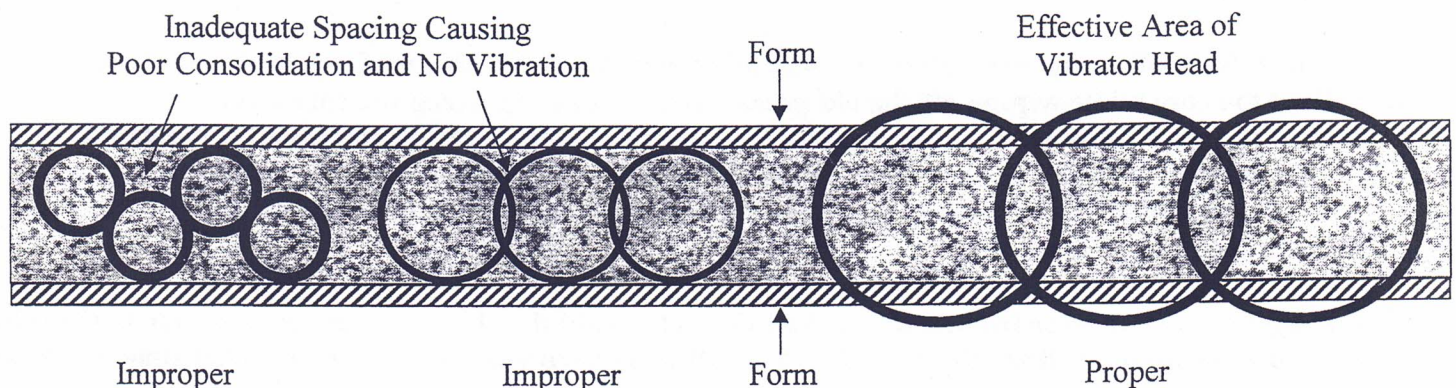

VIBRATOR SERVICE INSTRUCTIONS

Proper Maintenance Of This Rugged, High Performance Concrete Vibrator Will Pay Off In Freedom From Breakdowns And Costly Repairs.

JE MOTOR MAINTENANCE AND SERVICE

WARNING!: IF REPLACEMENT OF THE POWER SUPPLY CORD IS NECESSARY OR ANY INTERNAL MOTOR REPAIR IS NEEDED IT MUST BE PERFORMED ONLY BY THE MANUFACTURER OR A FACTORY TRAINED AND AUTHORIZED SERVICE TECHNICIAN. **IMPORTANT:** Please notify DREYER VIBRATOR CO., INC. to repair your vibrator or direct you to the nearest DREYER AUTHORIZED SERVICE CENTER. Toll Free – (888) 494-8886. Dreyer Service Technician Certification Training is available from the factory.

1. **CAUTION:** If you are not a factory trained service technician, never turn on or plug in a motor unless the flexible shaft and vibrator head are completely assembled to the motor. The turning motor drive tip creates a possible risk of injury and universal motors can be damaged by excessive speeds developed without the proper torque load.
2. **Keep the exterior of the motor as clean as possible.** The motor is air cooled by a fan on the internal armature. To avoid airflow restriction, pay special attention to the slots on the front end bell of the motor and the air vents behind the rear motor cover. Keeping these areas free and clear of dried concrete and debris will avoid damage to the motor, caused by overheating.
3. **Always inspect power supply cords for damage before connecting the vibrator to power.** Keep the conductive prongs on the plug clean from dried concrete and debris. Closely inspect the plug. Check to see if the ground prong is loose or broken, or if the conductive blades appear to be burnt or damaged. Check the supply cords' insulating sheathing and the cord protector bend relief at the base of the motor for any breaks, cuts, bare wires, or severe dog-legs. If any of these conditions of cord damage exists, take the motor out of service immediately. **FAILURE TO DO SO COULD RESULT IN ELECTRIC SHOCK.**

JE FLEXIBLE SHAFT LUBRICATION AND MAINTENANCE

All JE shafts are pregreased at the factory and shipped ready for service. It is recommended to lubricate the flexible core EVERY 150 HOURS OF USE to maintain peak performance of your vibrator. Avoid overgreasing, this can force grease past the head seal. It is better to grease moderately. To lubricate the shaft follow these steps:

1. Remove shaft following instructions on Assembly page and leave the head assembled to shaft.
2. Pullout the core while wiping off the old grease with a clean rag. Keep the core clean.
3. Inspect the core. Look for flat, worn areas. If there is excessive wear, replacement is indicated.
4. With a palmful of DREYER shaft grease, grab the core with a semi-closed hand. Run an even coat of grease over the entire length of the core while feeding it back into the casing.
5. Reassemble shaft to motor.

CAUTION: Always replace broken or cracked shafts to avoid the risk of injury and damage to the other components. Avoid operating vibrator with the shaft in a sharp bend for a long period of time to prevent unnecessary core wear.

JE STANDARD SHAFT CASINGS ARE REVERSIBLE FOR DOUBLE LIFE

VIBRATOR HEAD MAINTENANCE AND SERVICE

The vibrator head should be disassembled, cleaned and lubricated after 200 hours of operation. To identify parts, check parts list on Page 16 of this manual. To perform this procedure follow the steps below:

1. Remove the vibrator head from the shaft. Remember - LEFT HAND THREADS.
2. Open the vibrator head. Clamp the head cone into a pipe vise making sure the jaws of the vise are not on the break between the head cone and tube. With a pipe wrench, grasp the head tube near the round steel tip. Turning to the right, break the tube loose from the head cone. LEFT HAND THREADS.
3. Remove the eccentric weight assembly from the head tube. Wash all parts thoroughly with solvent and wipe dry with a clean rag. A bottlebrush is useful in cleaning out the head tube. All parts should be kept as clean as possible.
4. Rotate the bearings by hand, to check for looseness or rough rotation. Check the eccentric weight drive for excessive wear on the area where the seal rides. If these conditions exist, replacement is required.
5. If bearings require replacement, remove snap ring and press off the lower bearings with an arbor press or bearing puller. To remove the upper bearings, unscrew the eccentric weight drive by placing cut out portion of the eccentric weight in a vise and using a 1/4" hex wrench to remove the weight drive from the eccentric weight - RIGHT HAND THREADS. Never use any tool that will mar the surface of the eccentric weight drive.
6. It is recommended to replace the grease seal during head service. The purpose of the grease seal is to prevent shaft grease from entering the head tube and damaging the bearings. Remove the used seal by driving a screwdriver in between the O.D. of the seal and the I.D. of the head cone. Pry inward to collapse the seal. Press the new seal into the head cone making sure it is installed in the proper direction. Do not apply more pressure than is necessary to seat the seal.
7. Into the clean dry head tube, pour the recommended amount of Dreyer head oil. Part #CL5167.

<u>VIBRATOR HEAD DIAMETER</u>	<u>AMOUNT OF OIL</u>
<u>1 - 1/8"</u>	<u>1/2 OZ.</u>
<u>1 - 3/8"</u>	<u>1/2 OZ.</u>
<u>1 - 3/4"</u>	<u>3/4 OZ.</u>

IT IS IMPORTANT TO USE THE PROPER AMOUNT OF HEAD OIL. Excessive amounts of oil will restrict movement of the eccentric weight and less oil than recommended will starve the bearings for lubrication.

8. Insert the rebuilt eccentric weight into the head tube and reassemble the head. Make sure to tighten the head cone to the tube as tight as possible to avoid concrete from entering the head.

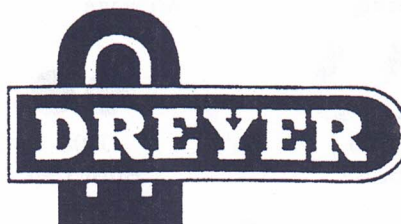

JE MOTOR PARTS LIST

JE MOTOR HOUSING ASSEMBLY

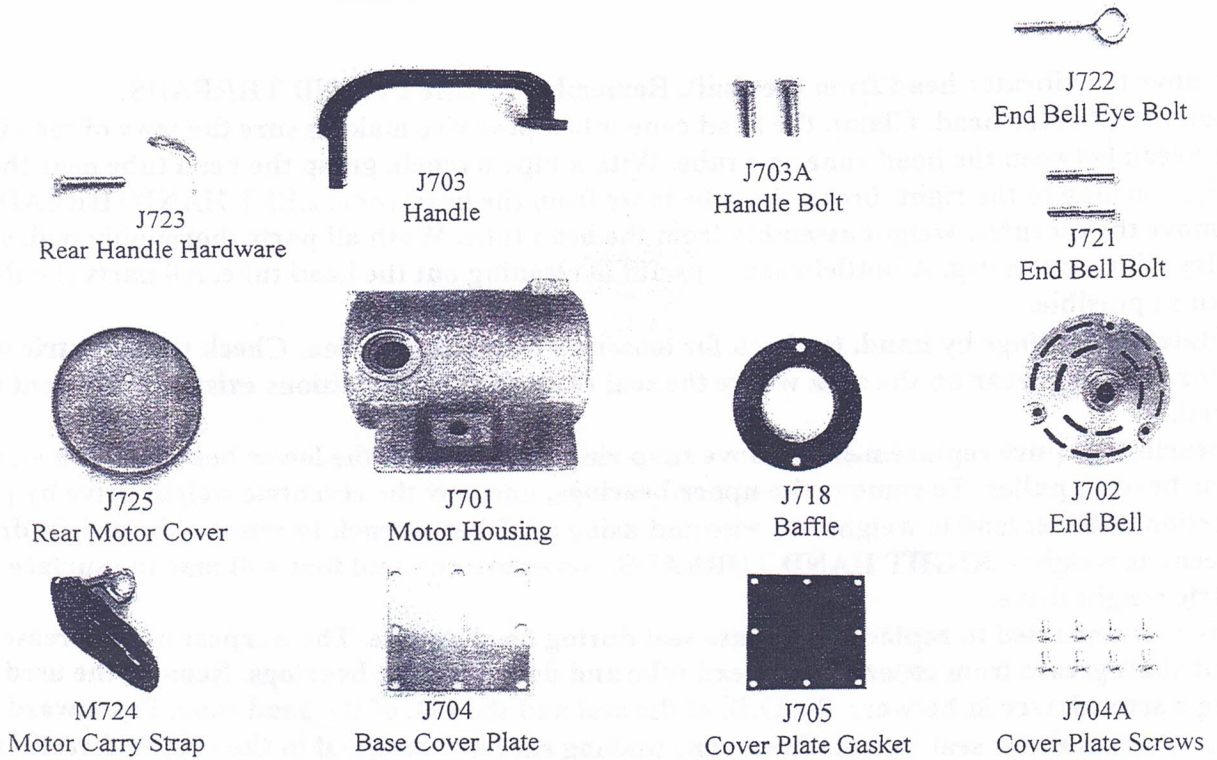

JE ELECTRIC MOTOR PARTS

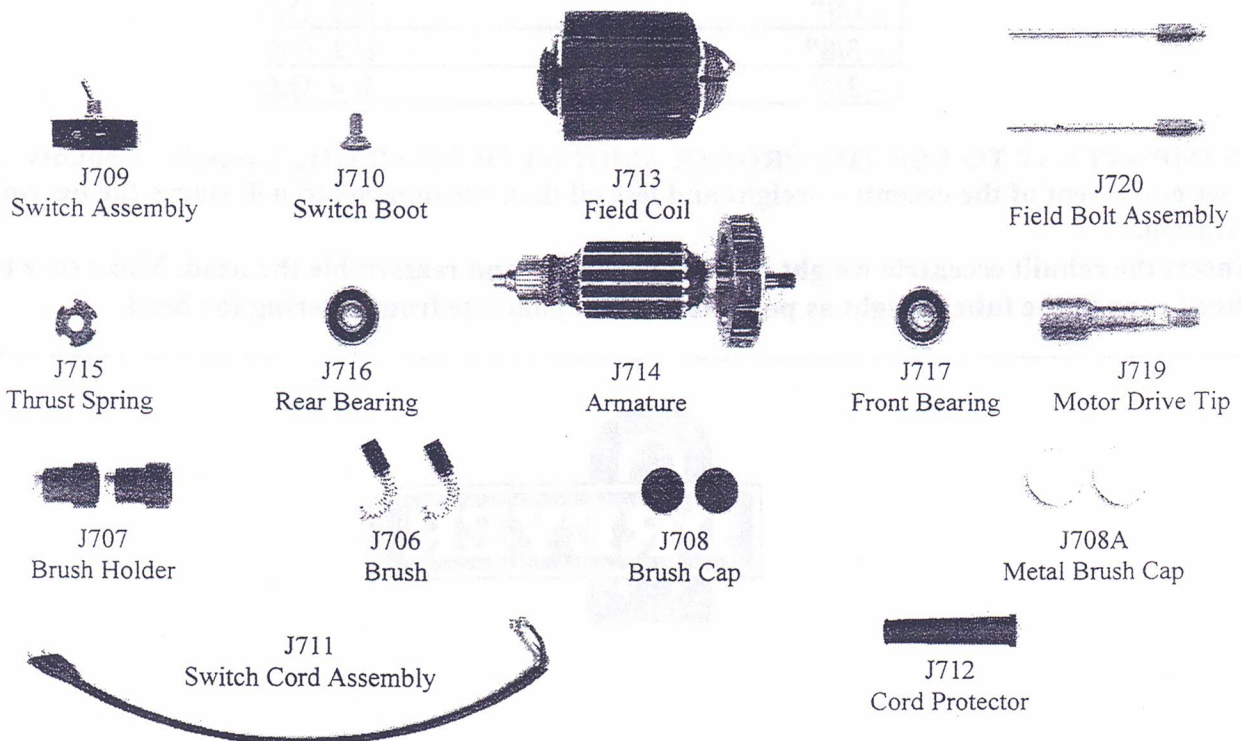

VIBRATOR HEAD PARTS LISTS

1 -3/4 Head Parts



13400
1-3/4" Tube



13402
Eccentric Weight



13404 Eccentric
Weight Drive



J13408
Head Cone



13409
Grease Seal



13406
Bearings (3)



13405
Snap Ring

1 -3/8 Head Parts



13800
1-3/8" Tube



13802
Eccentric Weight



13804 Eccentric
Weight Drive



J13808
Head Cone



13809
Grease Seal



13806
Bearings (4)



13805
Snap Ring

1 -1/8 Head Parts



11800
1-1/8" Tube



11802
Eccentric Weight



11804 Eccentric
Weight Drive



J11808
Head Cone



11809
Grease Seal



11806
Bearings (5)



11805
Snap Ring

13/16 Head Parts



131600
13/16" Tube



131602
Eccentric Weight



131606
Bearings (6)

131604 Eccentric
Weight Drive

NOTES:



JE VIBRATOR HEAD PARTS:

<u>PART NUMBER</u>	<u>DESCRIPTION</u>
J13411	1-3/4" Head
13400.....	Tube
13402.....	Eccentric Weight
13404.....	Eccentric Weight Drive
13405.....	Snap Ring
13406.....	Bearings (3 Required)
J13408.....	Head Cone
13409.....	Grease Seal
J13811	1-3/8" Head
13800.....	Tube
13802.....	Eccentric Weight
13804.....	Eccentric Weight Drive
13805.....	Snap Ring
13806.....	Bearings (4 Required)
J13808.....	Head Cone
13809.....	Grease Seal
J11811	1-1/8" Head
11800.....	Tube
11802.....	Eccentric Weight
11804.....	Eccentric Weight Drive
11805.....	Snap Ring
11806.....	Bearings (5 Required)
J11808.....	Head Cone
11809.....	Grease Seal
J131611	13/16" Head
131600.....	Tube
131602.....	Eccentric Weight
131604.....	Eccentric Weight Drive
131606.....	Bearings (6 Required)