

# VICTORIA ONE DESIGN

## CLASS RULES

### REVISION 13

October 2022

## THUNDER TIGER VICTORIA

Length Over All (LOA): 30.7 inches (779mm)

Displacement: 4.5 pounds (2.04Kg)

Sail Area: 433 sq. inches (28.6 sq. dm)

Mast Height: 43 inches (1092mm)

## INTRODUCTION

The Victoria Class is one of the largest and most popular R/C classes. The appeal of the Victoria is the fact that it is a low-cost boat with good performance. While the class is officially designated as a one design class by the AMYA, the class rules allow owners the flexibility to experiment and upgrade the rig, sails and rigging within clearly defined parameters.

### 1. GENERAL

- 1.1 The class shall be called the "Victoria One-Design". Victoria One-Design Class Sailboats shall be built from a kit manufactured by Thunder Tiger (hereinafter "KIT").
- 1.2 The class specification is defined by these AMYA class rules, the manufacturer's instruction booklet at the time the KIT was assembled, and any applicable rules of the AMYA, in that order of precedence.
- 1.3 The definitions, dimensions, and restrictions listed are intended to maintain the one-design concept for this class. The rules are intended to ensure that all boats are kept as close as possible with regard to *hull*, *deck*, *keel*, *rudder*, displacement, and ballast, while allowing variations in rigging and sails.
- 1.4 Unless a *modification* is specifically allowed by these class rules, it shall be prohibited.

### 2. DEFINITIONS

- 2.1 When a rule uses one of the following definitions, that word will be in *italics*.  
MODIFICATION: is any alteration to a KIT-supplied component including, but not limited to, sanding, grinding, drilling, cutting, reshaping, piercing or deforming.
- 2.2 HULL: that portion of the hull/deck molding extending below the gunwale.
- 2.3 DECK: all portions of the hull/deck molding extending above and inside the gunwale including the hatch, cockpit, cockpit sidewalls, cockpit bulkhead, and transom.
- 2.4 KEEL: consists of the KIT-supplied plastic *keel* fin with attached steel shaft and kit supplied lead or steel bulb, or alternate bulb. Alternate bulb dimensions shall be within +/- 1 mm of KIT bulb dimensions. Alternate bulb and KIT-supplied *keel* assembly shall weigh between 1,000 grams and 1,100 grams.

2.5 RUDDER: consists of the KIT-supplied plastic *rudder* fin with attached steel shaft.

### 3. FAIRING AND FINISHING

3.1 The *hull*, *deck*, *keel* and *rudder* shall be as supplied by the KIT. No *modification* to shape, contour or maximum thickness shall be allowed except as expressly provided by these rules.

3.2 *Hull*, *keel*, or *rudder* mold marks and surface imperfections may be filled or removed by sanding, polishing or painting provided the original surface contour is not altered.

3.3 The *deck* may not be made thinner by sanding but may be sanded in preparation for painting and any new or existing holes or recesses in the *deck* may be filled with any material and faired flush with the immediately adjacent *deck* surface.

3.4 The trailing edge of the *keel* fin or *rudder* may be sanded to a sharp edge provided the outline shape and maximum thickness of the fin is not changed.

3.5 *Keel* mounting screw holes and damaged areas of the *keel* may be filled or removed by sanding provided the original bulb profile, shape and thickness is not altered.

3.6 *Rudder* profile corners shall not be rounded in excess of 1/8-inch (3.2 mm) radius.

### 4. HULL, DECK AND DECK FITTINGS

4.1 Reinforcements for the purpose of strengthening or repairing the *hull* or *deck* may be added anywhere inside the *hull*.

4.2 The layout of the *deck* may be *modified* to accommodate rigging controls.

4.3 Alternate *deck* fittings for the jib pivot, mast step, shrouds, backstay, sheet exit guides and fairleads are permitted and their location is left to the skipper's discretion.

4.4 New or different sheet access holes, rudder linkage holes, or holes for each of a charging jack, receiver antenna, and battery switch may be added in any location on the *deck* provided the hole is no larger than necessary to accommodate the fitting, but never larger than 1/2 (12.7mm) inch in diameter.

4.5 The KIT *rudder* linkage hole in the cockpit bulkhead, the plastic pushrod exit bushing and plastic upper *rudder* shaft tube bushing may be used, *modified*, or omitted to allow for alternate *rudder* control systems and any such system, including *modification* to the *deck* for such systems, is left to the skipper's discretion.

4.6 The aft cockpit cover may be used, *modified*, or omitted. A substitute material may be used to cover all or part of the cockpit.

4.7 The KIT-supplied steering columns and wheels, winches and cleats may be omitted.

4.8 A single drain hole, not exceeding 1/2 inch (12.7mm) in diameter and for the sole purpose of removing water from the *hull*, may be located anywhere on the *deck*.

### 5. HATCH AND HATCH OPENING

5.1 Hatch cover, including the hatch slides, may be replaced with an alternate hatch cover. Material and shape of an alternate hatch cover is left to the skipper's discretion.

5.2 The hatch opening shape is left to the skipper's discretion but may not exceed 5 15/16 inches (150mm) in length and 3 9/16 inches (90mm) in width.

## 6. KEEL AND BULB

6.1 KIT-supplied parts related to the *keel*, but not included in the definition, may be omitted or replaced.

6.2 A *keel* shaft tube shall be installed inside the *hull* and the KIT-supplied brass shaft tube may be replaced with any material of similar function.

6.3 The *keel* shaft shall not be shortened and shall be installed inside the *keel* shaft tube. The top of the shaft may be re-threaded, drilled or be milled flat on any side to accommodate alternative securing methods.

6.4 The *keel* may be either permanently attached or removable but must be secured in its recessed mounting slot in the *hull*.

6.5 The *keel* depth with *keel* attached and secured in its recessed mounting slot in the *hull*, shall not exceed 7 inches (177.8mm) in depth measured, perpendicular to the waterline, from the point where the trailing edge of the *keel* fin intersects the *hull* to the bottom of *keel bulb*.

## 7. RUDDER

7.1 A *rudder* shaft tube shall be installed inside the *hull* and the KIT-supplied brass tube may be replaced with any material of similar function.

7.2 The *rudder* shaft shall not be shortened. The top of the shaft may be drilled or milled flat, on any side, to better accommodate alternate securing methods.

7.3 The number and type of connections between the *rudder* servo and the *rudder* control arm is left to the skipper's discretion.

## 8. DISPLACEMENT AND BALLAST

8.1 The minimum ready-to-sail weight shall be 4.5 pounds (2.04Kg).

8.2 The ready-to-sail weight includes radio receiver, batteries, steering servo, sail control unit, hatch cover, the cockpit cover (if used), sails, rigging and additional ballast.

8.3 Additional ballast shall be added to the interior of the *hull* to meet the minimum weight.

## 9. MAST AND BOOMS

9.1 The mast and booms may be constructed of any material.

9.2 The cross-section of any mast or boom shall not exceed 3/8 inches (9.5mm).

9.2.1 Any fitting, tangs, and attachment points are not considered part of the boom or mast with respect to measuring the boom or mast's diameter.

9.3 Mast height, when measured from adjacent *deck* surface to the cap part of the mast, shall not exceed 43 inches (1092mm).

9.4 A backstay crane of any material may be installed at the top of the mast and shall not be more than 4 inches (101.6mm) in length, measured along its axis from the aft face of the mast.

- 9.5 The use of a wind indicator or vane on the top of the mast is allowed, and shall not be included in the restriction on mast height.
- 9.6. The main boom length, including the gooseneck fitting and any attachments, and the jib boom length are left to the skipper's discretion.
- 9.6.1 Solid attachments are permitted. The side profile surface area of all attachments to both booms (when held on the boat's centerline) shall not exceed 5 square inches. This shall include the gooseneck and attachment fitting, vang and attachment fitting, and any other boom attachments if attached together as one unit. Mainsheets, jib sheets, and any knot or clip that attaches them to the boom shall not be included in this measurement.
- 9.7 A jib boom counterweight, and/or topping lift may be added, however, no portion of the jib boom, or attachments thereto, shall project forward of the bow of the boat while the jib boom is held on the boat's centerline.

## 10. STANDING AND RUNNING RIGGING

- 10.1 Standing or running rigging may be composed of any combination of KIT-supplied, commercially available, or homemade fittings, and the type of line or wire used for rigging is left to the skipper's discretion.
- 10.2 Standing rigging, including the mast step, shall be adjusted only by manual means.
- 10.3 The mast shall be stepped on or above the *deck* surface and on the centerline of the *deck*.
- 10.4 The number of spreaders and shrouds, including jack and jumper stays, is left to the skipper's discretion, except that at least one shroud per side (port and starboard) and one backstay shall support the mast. Freestanding masts are not allowed.
- 10.5 The forestay and/or jib-stay must be attached to or run through a fitting attached to the mast that is no higher than 37 1/2 inches (952.5mm) measured from the adjacent *deck* surface along the mast face. If an attachment or standoff fitting is utilized, the attachment point shall not exceed 1/4 inch (6.4mm) from the front of the mast.
- 10.6 The use of separate or multiple sheeting control lines for the jib and main is permissible, provided only those controls are operated by the sail control servo.
- 10.7 The manner in which the sheets or other sail angle controls operate, including any fittings mounted on, through, or below the *deck* is left to the skipper's discretion.

## 11. SAILS

- 11.1 Sails will be measured to the Sail Plan. Sails may be measured on or off the rig.
- 11.2 Smaller sails are allowed. Smaller sails must fit within the maximum limits as shown in the Sail Plan (Section 14).
- 11.3 Sails may be of single or multi-paneled construction. Sail material is left to the skipper's discretion.
- 11.4 The material used for corner reinforcements, broad seam reinforcements, batten pockets and battens are left to the skipper's discretion.
- 11.5 Halyard, downhaul, and clew outhaul attachment points shall be placed within 1/2 inch (12.7mm) of each sail corner.
- 11.6 The method used to attach the mainsail to the mast is left to the skipper's discretion.
- 11.7 *Unmodified* sails from the Victoria KIT are always allowed and do not need to be measured.

11.8 Battens may be fitted to the mainsail and jib, with a maximum of three on the mainsail and two on the jib. If battens are used, they may be any length and shall be placed so as to divide the leech into approximately equal segments.

11.9 Multiple suits of sails may be used during a regatta at the discretion of the skipper.

## 12. IDENTIFICATION ON SAILS

12.1 RRS Rule 77 is deleted and replaced with the rest of this rule.

12.2 The Victoria Class insignia is a single letter capital 'V', at least 2 inches (52mm) in height, times New Roman font and shall be placed on the top 1/3 of the mainsail. The class insignia may be placed back-to-back or at different heights on the two sides of the sail. When placed at different non-overlapping heights, the insignia on the starboard side shall be uppermost.

12.3 Sail numbers shall be at least the last two digits of a boat's registration number (as assigned by the Class Secretary) and shall be at least 3 inches (76mm) in height and shall be solid Arabic Numbers of an easily readable font.

12.4 Sail numbers shall be placed in the middle 1/3 of the mainsail and on the bottom 1/2 of the jib.

12.5 Sail numbers shall be placed at different non-overlapping heights on the two sides of the sail, those on the starboard side being uppermost. The only exception to this is if the numbers are such that they coincide when placed back-to-back on both sides of the sail, they may be so placed.

12.6 In the case of duplicate numbers, the Race Committee may require that one or more boats with the same number temporarily add a '1' or other number to a boat's sail number.

12.7 Victoria Kit sails need not display the logo and sail numbers may be 2 inches in height. They may be placed to fit between the graphics.

## 13. RADIO EQUIPMENT

13.1 No more than two servos are allowed; one shall be for sail control, the other for *rudder* control.

13.2 The method of fixing radio equipment, servos, receiver and batteries, to the *hull*, and or *deck*, are left to the skipper's discretion.

13.3 The number and type of battery cells may be changed during a regatta provided that Class Rule 8.1 is not broken.

13.4 Servos, receivers and batteries shall not be movable during a heat, but may be moved between heats.

## 14. Sail Plan

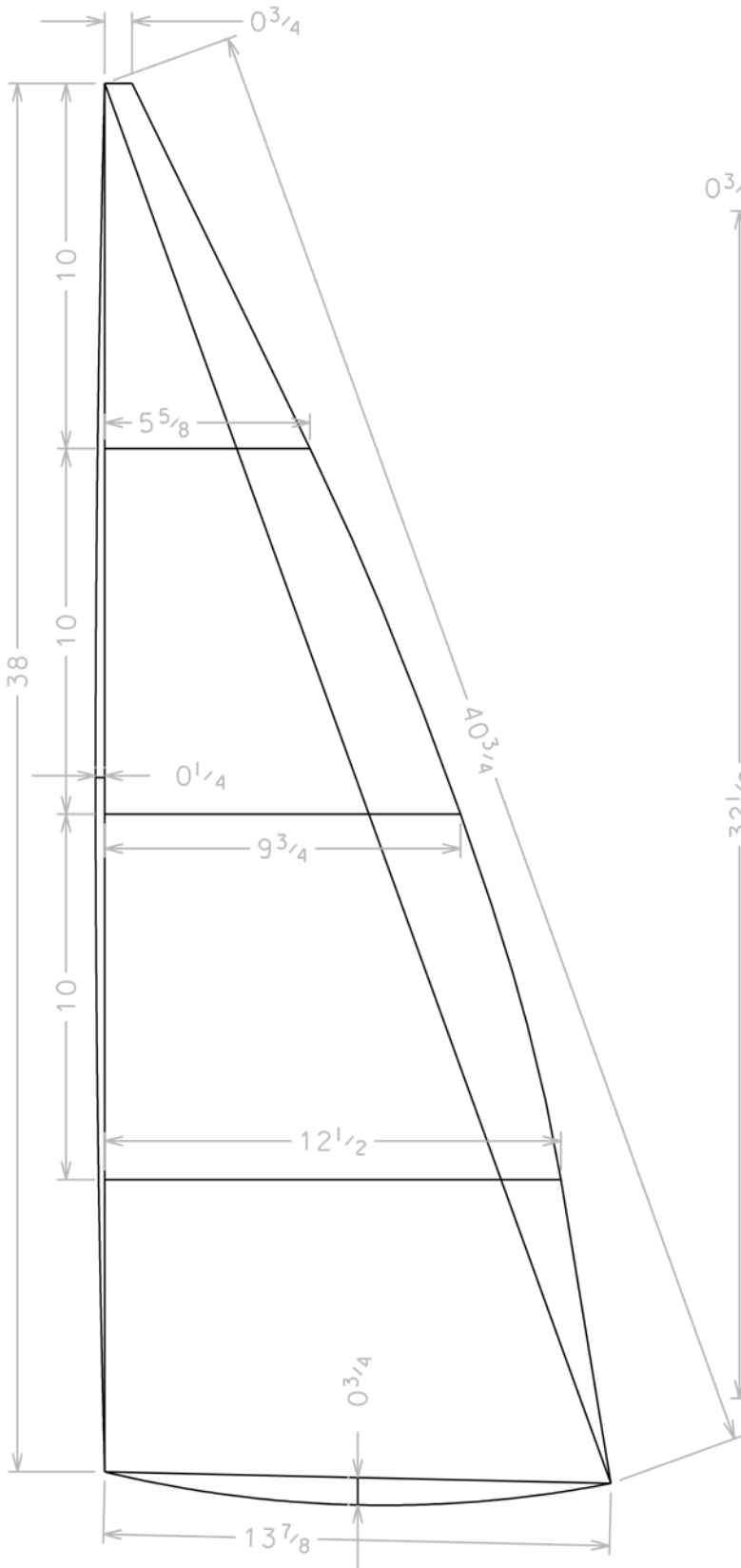

Main

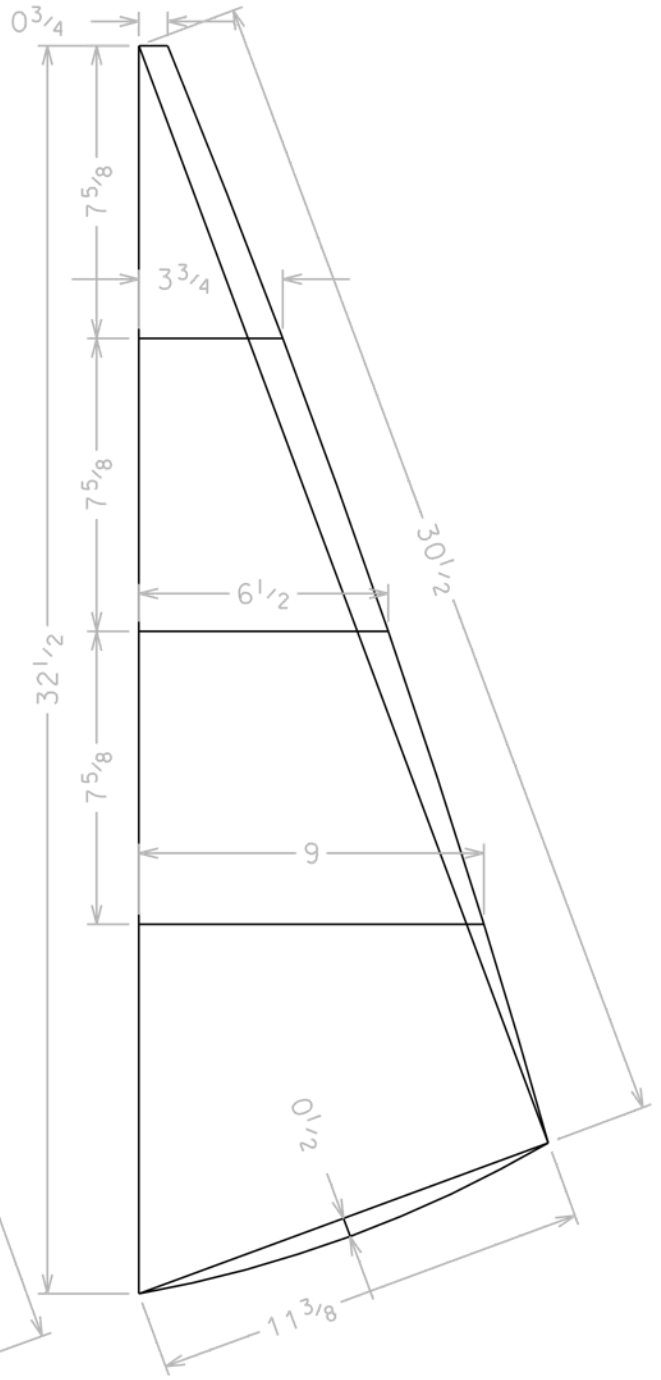

scale:  $\frac{1}{5}$  or 1 in = 5 in

Jib