

日常維護與檢查

- 每日：**檢查刀具磨耗或損傷，判斷已失效則立即更換。檢查空壓源的過濾水杯是否已滿，適時排水。檢查氣銼機的潤滑油滴速是否正常。
- 每週：**檢查氣銼機運轉是否順暢無異音。檢查浮動行程是否平順而且能回到機械原點，在機械原點時以手輕搖氣銼機的機械間隙應小於 0.5mm。如果發現任何機械作動的瑕疵，請聯絡您的供應商。

使用前須知

- 按照下圖所示準備合適的空壓源，粗線管路最大流量需大於工具的耗氣量。

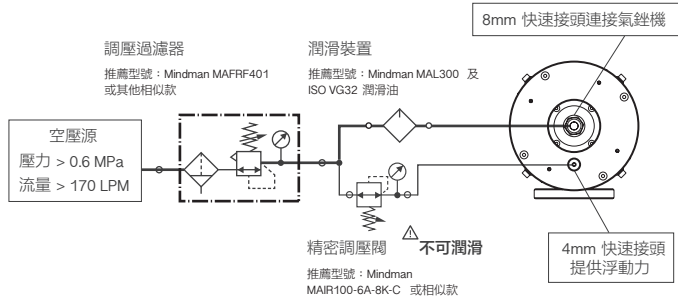

- 檢查氣銼機的機械原點 (*1)，在氣銼機靜止的狀態下給予浮動氣源 0.1 MPa 的壓力。確認氣銼機可以回到機械原點，如同下圖所示。如果氣銼機沒有歸位或不在機械原點上，請聯絡您的供應商。

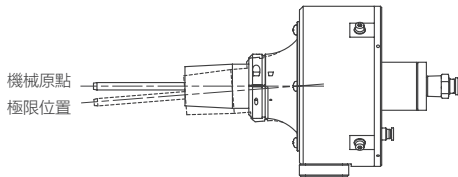

- 當氣銼機回到機械原點，給予氣銼機空壓使其運轉並聆聽它的高頻聲響。如果聽到任何較低頻的聲音或雜音與高頻聲並存，或是氣銼機無法作動，請聯絡您的供應商。
- 利用沉頭孔與定位銷孔將浮動工具安裝在機械手臂上或某個固定位置。(*2)
- 在機械手臂控制器裡設定浮動工具的 TCP (工具座標)，可以使用圖面上的位置或用四點校正法。(*3)
- 您已完成使用前的準備工作，可以開始機械手臂路徑的示教或自動生成。

示教機械手臂路徑

- 使氣銼機回到機械原點上，然後讓主軸在工件上移動 (*4)，示教出一個路徑讓去毛邊刀具 (圓銼刀) 保持和毛邊 (或需要移除的部位) 剛好接觸到。

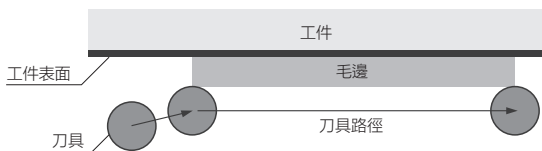

- 在前一步示教出來的路徑上加上一個偏移量 (虛擬的切深)。偏移量的目的是預防刀具和工件脫離接觸，並且提供穩定的接觸力量 (浮動力)。設定干涉量的關鍵在於想像一條刀具位於機械原點時所走的虛擬路徑，要大於所有需要被吸收的公差之總和，但要小於 3mm 以避免撞擊到浮動行程的極限。

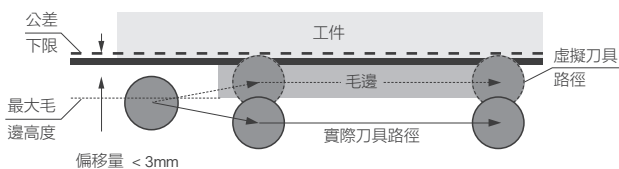

- 如果因為毛邊太高無法讓偏移量小於 3mm，可能需要在相應的路徑上重複作動數次，且每次都讓虛擬的切深更接近最後的目標。
- 如果機械手臂路徑是曲線，需要比直線使用更多的路徑點位。當毛邊大時降低機械手臂的速度，反之則加快速度。在正式執行去毛邊之前，確保機械手臂路徑已經順暢。

執行去毛邊

- 將浮動力設定在較小的數值，例如 0.2 MPa，打開氣銼機空壓源並執行機器人工路徑。
- 如果毛邊沒有被完全去除，則調高浮動力。如果有部分毛邊沒有被去除，在沒有完全去除的線段調降機械手臂速度。如果切得太深，調低浮動力或加快機械手臂速度。
- 如果刀具在工件上彈跳，這是因為浮動力太小，調高浮動力或調低機械手臂的速度可解決此問題。
- 如果氣銼機在執行去毛邊的時候明顯轉速過低或停止，這是因為材料移除率過高，調低浮動力或調低機器速度可解決此問題。

注意事項

- 本產品專門設計用於機器人去毛邊工作，勿使用於任何其他用途。
- 當機器人運行在自動模式時勿靠近，以免發生危險。
- 刀具或毛邊可能割傷人體，工作時應特別注意。
- 碰撞可能造成刀具或浮動工具的損壞，全自動執行機械手臂路徑前務必檢查。
- 刀具在工件上嚴重的彈跳可能會使浮動工具受損，在執行全自動模式前應先檢查。
- 供應精密調壓閥與浮動力的空氣不可潤滑，否則會使浮動工具損壞。
- 執行去毛邊的聲音對人的聽力有害，工作中永遠佩戴抗噪耳塞。

技術資料

浮動角度 (°)		3.5 (徑向)
浮動力 (N)		6-30
額定工作壓力 (MPa)		浮動力: 0.1-0.5, 氣銼機: 0.6
空壓源		> 0.6 MPa、乾燥、過濾 ≤ 5µm
耗氣量 (lpm)		浮動力: 可忽略, 氣銼機: 170
潤滑油 (滴 / 分鐘)		1-2 (只能潤滑氣銼機)
氣動主軸自由頻率 (bpm)		9000
氣銼機往復行程 (mm)		10
適用刀具柄徑 (mm)		5
工作溫度 (°C)		+5~+35
工作濕度 (%)		<95
重量 (kg)		2.9

*1. 機械原點可能不會完全剛好落在圖面上的位置，如果有小於 0.5mm 的公差或間隙都是正常的情况。

*2. 請洽您的供應商以取得浮動工具的三維及二維圖面，或從官網下載。

*3. 一開始建議先使用圖面上的位置然後再用四點校正法修正 TCP 的精準度，TCP 的詳細設定與校正式請洽您的機械手臂供應商。當您使用四點校正法時，需要以一個具有尖點的治具來指示您想要設定的 TCP 位置。

*4. 機械手臂拿工件或工具都可以，視系統整合的需求而定。



Maintenance

- Daily:** Check whether the deburring tip is damaged or wore, replace it immediately when it has invalid. Check air conditions and keep it dry, clean and lubricated. Check the lubricating oil drip rate is normal.
- Weekly:** Ensure the pneumatic file operates smoothly without weird noises. Make sure compliant tool movements work smoothly, as well as the pneumatic file is able to return to the **CENTER POINT**. Shake the pneumatic file gently by hand at the **CENTER POINT**, and the gap should be less than 0.5mm. If any defect is discovered, please contact your supplier.

Before Use

- Prepare a suitable air source as shown as the illustration below. The maximum flow rate of the thick lines should exceed the air consumption of the pneumatic file.

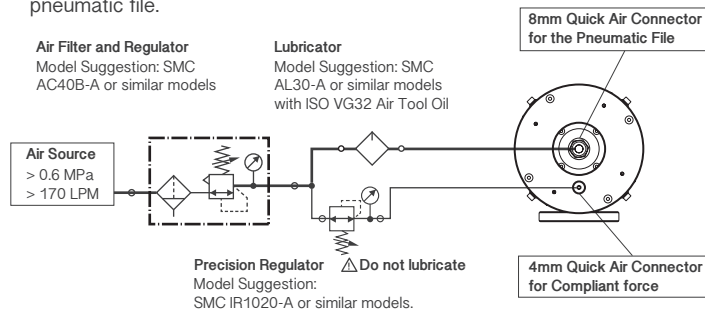

- Check the **CENTER POINT** (*1) first; giving 0.1MPa pressure to the compliant force connector while the pneumatic file is turning off. Make sure the pneumatic file is able to return to the **CENTER POINT** as shown as the illustration below. Please contact your supplier if it couldn't return to or is not on the **CENTER POINT**.

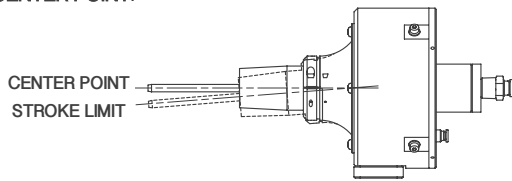

- Turn the pneumatic file on when it is on the **CENTER POINT**, and listen to its high-frequency sounds. If there are any other low-frequency sounds or noises, or if the pneumatic file doesn't work, please contact your supplier.
- Install the compliant tool on the robot or a fixed position by screw holes and pin holes (*2).
- Set up TCP (Tool Center Point) of the compliant tool in robot controller by using either designed dimensions or the four-point calibration method (*3).
- You have finished the pre-use preparation, now you can start teaching-in robot paths.

Teach-in Robot Path

- Return the pneumatic file to the **CENTER POINT** and move it on the workpiece (*4). Teach-in a path to keep the acting point of the round file in contact precisely with the burrs or the parts that needed to be removed.

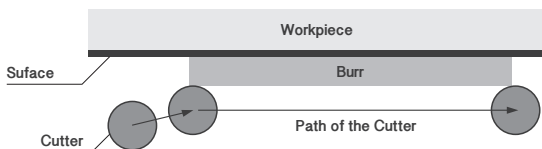

- Set an offset (virtual depth of cut) along the path you just taught-in at the previous step. The purpose of setting offset is to prevent the tip from detaching from the workpiece, and to provide a stable contact force (compliant force). The key of setting an offset is to imagine a virtual path of the cutter on the **CENTER POINT**, and the offset should be greater than the sum of all tolerances but smaller than 3mm to prevent the compliant tool from collision.

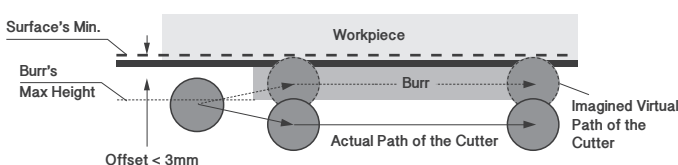

- If the burrs were too high to set an offset smaller than 3mm, it may be necessary to repeat the action several times over the corresponding paths, and each time bringing the virtual depth of cut of the **CENTER POINT** closer to the final position.
- If the robot path is curved, it may need to use more path points than a straight robot path. Slow down the robot when the burrs are large, speed up when they are small. Before officially activating the deburring operation, make sure the path of the robot works smoothly.

Operation

- Set the compliant force to a small value, such as 0.2MPa, then start operating the deburring process.
- Increase the compliant force if the burrs were not completely removed. If some were removed but some others not, slow down the robot in the corresponding segments. If the tips cut too deep, reduce the compliant force or speed up the robot.
- If the tip bounces on the workpiece, this is because the compliant force has been set too small. Either increase the compliant force or slow down the robot will solve this problem.
- If the pneumatic file is blocked during operation, it may be caused by the high material removal rate. Reduce the compliant force or slow down the robot will solve this problem.

Cautions

- This product is exclusively designed for robot deburring work, DO NOT use for other purposes.
- For your safety, DO NOT approach the robot when it is in automatic operation mode.
- Tips and burrs could cause injuries, be aware when you are working with them.
- Tips and compliant tools could be damaged by collision, check robot paths before setting in automatic operation mode.
- Compliant tools could be damaged by severe bouncing of the tips on the workpiece, check before setting in automatic operation mode.
- The air supplied to the precision regulator and the compliant force should NOT be lubricated, otherwise the compliant tools will be damaged.
- The noise from the deburring operation could damage your hearing, be sure to always wear earplugs at work.

Appendix

Compliant angle	(°)	3.5 (radial)
Compliant force	(N)	6-30
Nominal operating pressure	(MPa)	Compliant force: 0.1-0.5, Pneumatic File: 0.6
Air source requirement		>0.6MPa, clean, dry, filtered≤5µm
Air consumption	(lpm)	Compliant force: neglectable, Pneumatic File: 170
Oil consumption	(drops/min)	1-2 (for the Pneumatic File only, DO NOT lubricate the compliant part)
File idle frequency	(bpm)	9000
File stroke	(mm)	10
File shank diameter	(mm)	5
Ambient temperature	(°C)	+5~+35
Ambient moisture	(%)	<95
Weight	(kg)	2.9

*1. The **CENTER POINT** may not be exactly on the designed position. It's normal when there is a tolerance or a gap smaller than 0.5mm.
 *2. Please contact your supplier for 3D and 2D drawings of the compliant tool, or download it from our website.
 *3. It is recommended to start by using designed dimensions in the first place and then using four-point calibration method to improve the accuracy of TCP. When you implement the four-point calibration method, you need to indicate the point of TCP that you want with a sharp dummy tip.
 *4. Both workpieces or tools on hand are possible for the robot, depends on the aspect of system integration requirements.