

Manor Minutes

Volume 11 Issue 22

May 22, 2020

Coronavirus update: The Reopening the Church Building Task Group and our Trustees have designated Saturday, June 6, as a preparation day for the rooms and hallways that we will be preparing for reopening of the church building. Although no date for reopening has been set, there is work to be done in preparation. If you are interested in assisting, please come with your own facemask to the church at 9 am.

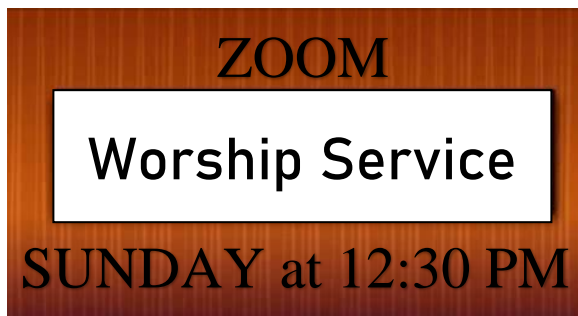

Zoom Worship
Meeting ID: 932-4557-4206
Password: 026316

<https://us02web.zoom.us/j/93245574206?pwd=cHdQMmlPWURmWkdqQUZmRXlMeGdudz09>



HEY CHURCH -We will be hosting another **DRIVE-THRU FOOD COLLECTION** – Saturday, June 6th from 10:00 a.m. – 12:00 p.m. at the front drive at FMCC 351 Montgomery Ave. We will be collecting non-perishable foods, especially, but not limited to, canned

tuna, other canned meats, Spaghetti -O's, canned Ravioli, peanut butter, jelly, mac 'n' cheese, pancake mix, syrup. Monetary donations will also be accepted. We will have a crew at the front steps to collect your items. There will be no need for you to get out of your car. Our crew will be social distancing, wearing face masks, and gloves. Please enter the drive-way off of Montgomery. This food drive is not limited to only Church folks so please let your neighbors and anyone else know that this is happening. Hope ALL is staying safe and healthy.... blessings to all.



Sunday at 11 AM

Meeting ID: 735-805-8215
Password: 550943

Applications for the **Reese Grant** can be found at <https://fairhillmanorchurch.org/reese-grant>.

This grant is open to any Fairhill member pursuing higher education (education beyond high school).
Due date is June 15.



Graduates!!

If you are graduating or you have a family member who is, please call the Church Office to let us know. Send an e-mail with the name of the graduate, school they are graduating from and their relationship to Fairhill member. Information is needed by June 4.





Fairhill Manor Christian Church

(Disciples of Christ)

351 Montgomery Ave.

724-225-8610

Rev. Dr. W. Darwin Collins, Interim Pastor

Rev. Gena Sheller, Associate Pastor

May 24, 2020

Welcome to our Home Worship Service!

Welcome*

Pastor Gena

Call to Worship*

Kathy Moninger-Ford

Welcome, in your sanctuary homes. Come with hearts excited to hear the promises of our Risen Christ. Celebrate anew to know of God's love for us and in us. Let us rejoice as we this very day live in the glory of Resurrection!

Opening Hymn*

“Come, Christians, Join to Sing”

organ by Audra Allan

Come, Christians, join to sing: Alleluia! Amen!
Loud praise to Christ we bring: Alleluia! Amen!
Let all with heart and voice, before his throne rejoice
Praise we with grateful choice: Alleluia! Amen!

Come lift your hearts on high: Alleluia! Amen!
Let praises fill the sky: Alleluia! Amen!
Christ is our Guide and Friend on whom we can depend;
His love shall never end: Alleluia! Amen!

Pastoral Prayer and the Lord's Prayer*

Pastor Gena

Loving God, present in every place and in every time, with us now and here, we are overwhelmed with thinking that we can know you, even a little bit, and talk with you anywhere and anytime we want to. You, our Creator, who saves us from ourselves, who walks in front of us to show us the way, who always has a place prepared for us. Allow the wonder and the honor of being in your presence to slowly enter our hearts. Give us the grace to recognize these as holy moments on holy ground.

We are glad to belong to Jesus, our Good Shepherd. We are grateful that he continually intercedes for us, his sheep. Help our trust in Jesus to grow as we know him more deeply and follow the sound of his voice more closely.

Gracious God, you have given us work to do and gifts with which to do it. Whether we are young or old or somewhere in between, open our eyes to see our purpose, where we fit into your great work of love. Give us the courage to set about the work to which you call us, even if we feel unqualified and frightened, trusting that you will qualify us and you will equip us, so that all will know that it is you working in us and through us.

Loving God, we struggle to know you, through your words and parables, through the narrative of your persistent love of your people throughout every time and place, through the world you have created and entrusted to us. And yet, somehow, we know that we will never know you fully until we see you face to face. Until that time, create in us the hunger to seek you and to know you better.

Lord Jesus, we know that you are interceding on our behalf, and so we intercede on behalf of those who need the love of God and the comforting presence of the Spirit now.

Be with those making decisions on behalf of others. Help us to choose life and health, understanding and unity wherever possible. Open our eyes to the most vulnerable and powerless among us, knowing that you see them and love them and center your kingdom around them. Make us one family gathered up in your love and clothed in the power of your peace.

We pray for those who are sick, for those who are struggling with addiction and those seeking recovery, for those who are anxious, frightened and without means to provide for those who depend on them. We pray for those who carry the burden of working face-to-face with this coronavirus every day.

And now we bring into the Light of your presence those who are known to us as needing your comfort and care, your help and guidance. In this silence, we name them to you....

You know, Lord, you know. Be with these who need your special care and show us how and when and where to be your Body in your world.

Open the doors of life-forever-with-you to us so that we might begin even now to live abundantly and joyfully, knowing that you never leave us or forsake us, even in the darkest times and places. We pray this in the name of Jesus, our Lord and Savior, who prayed to you and taught us this way to pray....

Our Father, who art in heaven, hallowed be thy name. Thy kingdom come, thy will be done on earth, as it is in heaven. Give us this day our daily bread, and forgive us our trespasses, as we forgive those who trespass against us. And lead us not into temptation but deliver us from evil; for thine is the kingdom, and the power, and the glory forever. Amen.

Anthem*

“Ain’t Dat Good News,” by The Moses Hogan Singers

<https://youtu.be/X6lkw3Hb-4E>

Children’s Message*

Pastor Gena

You might want to have a candle, a way to light the candle, and something with which to snuff the candle for today’s story. Make sure you have an adult right with you the whole time. That’s important so you can stay safe.

Let’s hear part of our Children Worship & Wonder story for today, “Ascension.” That’s a big word. Listen for what it might mean as I tell today’s story. Ascension.

Today is the seventh and last Sunday of the season of Easter, when we celebrate the mystery that Jesus died and that God made him alive again.

Today is also Ascension Sunday, when we celebrate another mystery – the mystery that Jesus went away so that he could be with us always – in every place and every time.

The Christ candle helps us remember the mystery of Easter. When there is no light, we say “Christ has died” and we cup our hands around the candle and move them down the candle. But Jesus is alive! God raised Jesus from the dead. So, we move our hands up the candle, light the candle, and say, “Christ is risen!”

Jesus was alive again. One day he said to his friends, “Stay in Jerusalem. God will send you another special gift, the gift of the Holy Spirit. The Holy Spirit will give you power, power to tell everyone about me and about the kingdom of God. I am going away. You won’t see me anymore. But I will be with you always. And I will come again.”

And then Jesus disappeared... into a cloud. To remember this part of the story, we put our snuffer over the flame to put it out, catching the smoke, and slowly lift the snuffer up into the air, releasing a cloud of smoke.

Hmm. This is the mystery of Ascension. Jesus went away, but somehow, he is still with us.

We slowly lower the snuffer and we look at the Christ candle and we say, “Christ will come again.”

Let’s do that one more time. We point to the wick which is not lit and we say “Christ has died,” moving our cupped hands down the candle. But we remember God raised Jesus from the dead, so we move our hands up the candle, light it, and say, “Christ is risen!” Then we remember that Jesus disappeared into a cloud, and we snuff the candle and release a cloud of smoke up into the air. We remember the good news that “Christ will come again” as we slowly bring the snuffer back down.

This is the mystery of Easter. Christ has died. Christ is risen. Christ will come again.

Dear God,
Thank you for Jesus.
Thank you for his Ascension,
For his leaving us so that he could be with us always,
In every place and every time.
Help us to feel him near.
Amen.

Scripture Reading*

Luke 24: 44-53
John 17: 1-11

Jim Ulery

Sermon*

“Jesus’ Straight-up Answer”

Rev. Collins

Her name was Dorothy. A lovely lady retired after nearly 20 years as a bank president’s personal secretary. She was not a particularly memorable woman for most, but my visit with her that early September day of 1975 was the most meaningful class I’ve ever taken on prayer in my life. Seated at her kitchen table with coffee and a sweet roll, Dorothy convened the class. After some conversation of her adjustments to her husband’s death, I offered to pray with her...then class began in earnest...she said, “I’ll appreciate your prayer very much, but after you’re finished, I want to pray for you.” That stopped me short. I’m the minister, I pray for the sick, the grieving, the ones in need. That’s my job, my calling...you pray for me?

Gratefully, I didn’t express my hesitations out loud, but I think she still recognized my reluctance and continued with an explanation. She said that her Mother had told her early in her life that prayer was not a mere recitation of requests or pleas, but the true conversation of love. And it was a gift offered by God to be shared with people who cared about each other and God. So, she told me, it was important to her that

she also participate in the conversation. I thought about explaining that I was not really in need of any prayer at that time...but thankfully, I remained quiet and acquiesced to her prayer...and it was a true

blessing. To be with someone whose focus of prayer was solely upon you, to hear your name and the expressions of another's hopes for you...that is moving and powerful. I had mentally believed that praying for someone else was moving and meaningful. I hoped so with every prayer I offered for others...but I didn't really recognize the power of prayer until that day in Professor Dorothy's kitchen.

That's where Jesus' disciples found themselves in this passage from John. Not out on a mountain somewhere with Jesus praying at a distance, beyond where they could hear. No, John says this was in the familiar setting where Jesus broke the bread and shared the cup, where he had washed their feet and talked of the importance of them caring for one another. At the table where he had given that extended sermon on loving one another, of the close relationship between God and Jesus, of his preparations for them after he died, of how they were linked to him like the branches of a grapevine, of the Spirit coming to be with them...here in that very close and intimate occasion Jesus ends this scene with a prayer. Note in John, there is no Lord's prayer, so in effect this is the Jesus Prayer in John's Gospel. And he prays for...them...in their presence. Dorothy may have very well been channeling Jesus in her kitchen prayer with me.

Think of that, what would that mean for you...not the general prayer that we just recited, as we do each Sunday...but Jesus praying in your presence a prayer for you. How do you think that would impact your life and the way you consider the challenges and joys you encounter? It is astonishing to me to think of Jesus praying for me...for you...for us.

He prayed that God would protect you...and to confirm that we are, in Christ, truly joined as one. And buried within this lengthy prayer is a remarkable revelation...the answer to a question that we ask from the depths of our hearts and are usually left with partial answers only...what is eternal life? We may recite the answers of greeting cards or poets, of prophets or our own appetites and desires...you know heaven is golden streets, flowing streams, maybe puffy clouds or endless golf courses with sunny skies, perhaps like a daily spa or sun-drenched beaches... But lying in the beginning of today's text, like the golden Easter egg waiting to be found in the grass, Jesus gives the straight-forward response to this perennial question.

And this is eternal life...no skirting the subject, no passing it off as a truth that must await death...no, Jesus says that eternal life is to know God and to know Jesus Christ. That's eternal life. It's that simple? As John reminded us last Sunday, it is summed up in being in a relationship with the Trinity—a relationship of love that starts even now...not awaiting death.

Eternal life is ours through that relationship in Christ...we are living here and now. We taste it at the Table, we sense it in the love and concern of others...eternal life began when you accepted Christ and became one with God. It's not in a creed or belief system, it's not going through the motions...it's knowing God. That's Jesus' prayer for you and me.

I suppose the closest description we have for this understanding of eternal life are those occasions when we are caught up in the moment or experience. When you are so intensely experiencing joy that you are oblivious to anything else...whether getting picked for the starting team, or winning a prize, or on your wedding day...or the birth of your child, or grandchild...it is the experience of being so special in the moment that nothing else matters. That's how Jesus describes our relationship with God...that's eternal life. And, yes, it's ours now! Think of that!

Call to Offering*

Jerry Puskarich

Good Morning:

Over the past 2 months we have experienced a pandemic of great proportions, something of which none of us has ever experienced. We have seen our church services, the important activities of our ministries and fellowship activities significantly impacted and we all miss those activities and the great experiences we have all come to love over the years. The COVID-19 pandemic has impacted the ability to receive the normal level of donations that are necessary to operate our church and the important outreach programs that depend on our contributions. However, the expense requirements for our church have not changed. As a result, the Stewardship/Finance Ministry during the month of April decided inquire about the possibility of applying for a Payroll Protection Program Loan which is better known as a PPP Loan. The program is part of a suite of tools that are designed to help small businesses including non-profit organizations to financially navigate through the COVID-19 Pandemic. It falls under Coronavirus, Aid, Relief and Economic Security Act better known as the (CARES) Act that was signed into law back on March 27th.

The application for the loan was prepared by Brian Shaw and he should be thanked for his efforts in preparing the application and providing the necessary information to obtain the loan. The loan process is supported by the Small Business Administration and was applied through Washington Financial which is the bank that holds our bank accounts to operate the church. The loan was approved on Thursday, May 14th in the amount of \$24,510 with the loan proceeds being deposited into the General Fund.

The loan does have requirements in that it can only be used for certain expenses. These include payroll costs which include salaries, wages, and commissions which are below \$100,000 per employee; leave benefits; health care benefits; retirement benefits; and state and local payroll taxes. It can also be used to pay for interest on debt obligations that occurred before February 15, 2020 which falls under the roof loan, we have with the Disciples Church Extension Fund. The loan proceeds can also be used for utilities as well; but at least 75% of the proceeds must be used for payroll and the proceeds must be used over an 8-week period after the loan is approved. The use of the funds must be tracked to make sure they are applied to qualifying expenses. If all the funds are used under the required guidelines the loan is 100% forgivable. It is the priority of the Stewardship/Finance Ministry to ensure that those requirements are met and the all the funds are allocated and accounted for properly. The key element of this loan is that it is designed to help keep our minister, our associate pastor and our support staff employed all of which are vital to our congregation.

The approval of this loan is great news for Fairhill Manor Christian Church, its ministries and the outreach group's it supports. Let me make it clear that the receipt of the proceeds of this loan does not discount the importance of the generous giving we receive from our congregation, nor does it relieve us of the commitment we made last fall during the Stewardship Campaign. There are other important expenditures that will go on despite the pandemic. These expenditures include the cost to maintain the church property and office management expenditures, and our budgeted outreach expenditures. This important group of expenses comprise 20% of our total budget. We also have anticipated expenditures that will be incurred by our Pastoral Search Committee for the search for a new pastor which could be more than the \$5,000 we have in the budget. The other uncertainty of course is the possible return of the virus in the fall which could be worse than the first wave we have already experienced. The return of the virus could further stress our funds availability. Therefore, the loan is also an insurance policy should a return of the virus occur.

With that in mind we ask that you maintain your level of commitment as much as you can and to utilize the Givelify App which is the most safe and efficient way you can provide your gifts to Fairhill Manor Christian Church. May God bless each and every one of you as we continue through this journey together.

Invitation to Communion*

Rev. Collins

On this last Sunday of the Easter season, the Risen One is here among us, here and now. As he prayed for his disciples at that original Lord's Table, he prays for us at this table...and calls for us to be one with him and God and one another. To not look toward the sky, but into the faces of those who surround us to see God's face; to listen for God in the words of each other; by dining with them we share with God; to live peaceably God and them. May we hear Christ's voice and invitation to come and receive the gift of this new shared life, here and now.

Prayer for the Bread & Cup*

Connie Sheller

Our Father, you have always told us to come to you in times of our deepest need such as the one we find ourselves in now with this virus. We ask for hope, for love, for peace of mind, for good health, for contentment, for sustaining our faith and for opening our eyes and ears to the joys occurring around us each day even though we are sometimes clouded by our own fears.

We come to our individual tables to join Jesus and to commune with Him. We take our various emblems: the bread and the cup that represent to us Jesus' broken body and His shed blood. May we see Jesus at our tables, thankful for His dying on the cross and being raised from the dead to eternal life which is a life that is promised for each of us who believe in Him. Amen

Words of Institution*

Rev. Collins

Gathered with his followers around the table, Jesus took the bread and offering a prayer of thanksgiving to God, broke it and gave it to them and said, "Take and eat, this is my body given for you." Later in the meal he took a cup and offered a similar prayer of thanks to God. He gave it to them and said, "Take and drink. This is my blood of the new covenant in my blood shed for many for the forgiveness of sin." Join with all of us by eating and drinking these gifts of God for us, the people of God.

Benediction*

Rev. Collins

May the God of hope fill you with all joy and peace as you trust in him, so that you may overflow with hope by the power of the Holy Spirit. Amen.

* You can listen to these pieces of worship at <https://fairhillmanorchurch.org/worship-audio-files>



The Pastor's Cabinet formed three task groups to plan and prepare for the reopening of the church. There is no date, for a return to the sanctuary for worship, at this time. A return will be determined by the Commonwealth and we will follow CDC guidelines. If, in the meantime, you have any questions, thoughts or concerns related to the reopening please forward your concerns to one of the following three task groups:

- Task Group I** Preparation and care of the building, Terry Houston, Chair houstonterry@comcast.net
- Task Group II** Preparation for worship in the sanctuary, Rita and Kevin Puskarich
Co- Chairs Kevin7952@comcast.net and ritap87@comcast.net
- Task Group III** Communications, Cara Hritz, Chair, caradotson@gmail.com

Please continue to pray, not only for our church, but for all others churches, businesses, groups and individuals who are struggling at this time and ask God to grant us patience and compassion and to strengthen our love for one another.

Thank you. Gary Ford, Chair, Pastor's Cabinet



Please keep the Pastoral Search Committee in your prayers:

J.C. Leasure (Chairperson), Becca Caldwell, Jackie Nelson, Diane Palfreyman, Rolinda Sprowls and Mike Sweeney

If anyone is in need of food or knows of anyone who is, please contact Marsha Sams. She can be contacted by phone/text message at 859-421-7227 or e-mail at msams822@gmail.com.

Do you have a prayer request or need help? Please feel free to contact Pastor Darwin (412-337-4293) or Pastor Gena (724-263-0033) directly and confidentially. Or scroll down on the opening page of our website (www.fairhillmanorchurch.org) to "Requests for Prayer or Help." There you can send an email which will go directly and only to Pastor Darwin and Pastor Gena. We are One Body in Christ!

Prayer List:

Avery Allen	Dick Moninger
Bill Behrens	Jody Mullis
Bristol Allan Berry	Ed Palfreyman
Kassidy Brightwell	Joe Palfreyman
Mark & Susan Britko	Denny Paul
Diane Cope	Betty Jo Riggle
Emily Cope Robinson	Barb Roupe
Nick Cross	Shirley Sanders
Fred Engle	Beth Teagarden
Joe Greene	Melissa Teagarden
Bonnie Gregg	Shirley Teagarden
Judy Hanning	Gary Weaver
Aryn Hess	Nikki Wells
Ed & Harriet Jackman	Tom Williams
Dallas Jacobovitz	Chuck & Mary Wiseman
Tom Lane	Preparing for Baptism –
Cheryl Leach	Nyka Rash
Lee & Betsy Martin	
Ruth Mikuta	

In the Military

Lance Dague
Terrell McClain
Brandon Lipscomb
Daniel Robinson
Shawn Dallatore
Andrew Gregg
Zachary Keene
Sarah Lipscomb
Travis Ringer
Emily Chase



During this time of precaution and limited visitation, take a moment to send a card or note to those in nursing homes or who are homebound to let them know that you are thinking of them.

Southmont-Presbyterian Medical Center, 835 S Main Street, Washington PA 15301

Bill Behrens Rm 437

Rev. Marge Frank

Homebound Members:

Phyllis Cimino

317 Wellness Way

Strabane Trails #325

Washington PA 15301

Mrs. Mary McDonough

949 Bruce Street

Washington PA 15301

Fairhill Manor has entered a new era: the age of anytime, anywhere giving. We are now signed up with **Givelify**, the mobile giving app for places of worship and charities.

Givelify gives you a beautiful, easy giving experience using your smartphone. There are no frustrating web forms to fill out, and recurring gifts are easy to set up and modify. Even better, it's free to download and use. It's safe and secure and gives you access to your complete giving record.

Want to see how it works? [Watch the demonstration video](#) that shows you all about how to make and track donations.

Givelify

Tap. Give. Done.



May 23 Becky Ashmore
Paul Harton

May 24 Maria Sheller

May 26 Colton Crowe

May 27 David Davis

Cody Shultz

May 28 Deb Goodwin

Jerry Puskarich

Rev. Collins is available to you for your pastoral needs.

Cell: (412) 337-4293

Email: wdar1950@gmail.com

All **Outreach information** can be found on the FMCC website, <https://fairhillmanorchurch.org/how-to-help>.

Have a great day!

Choose happy 😊

Karen 5/22/2020

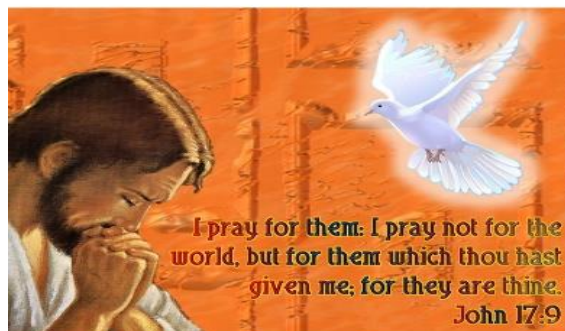

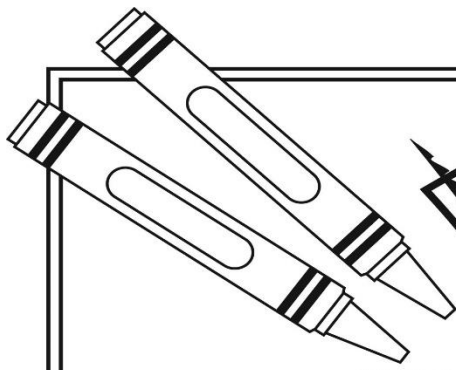

PUZZLE

GOD'S amazzzing BEES

God created bees to pollinate flowers and make honey. Psalm 119:103 says God gives us something that's even sweeter than honey.

Directions: Find the word that fits each clue. Then write the answers in the correct numbered honeycomb shape to complete Psalm 119:103, NIV.

CLUES

- | | |
|--------------------------|--------------------------|
| 1. rhymes with cow | 8. the tongue's job |
| 2. opposite of sour | 9. more sweet |
| 3. pronounced "R" | 10. rhymes with pan |
| 4. rhymes with four | 11. golden liquid |
| 5. Letters create _____. | 12. Pleased __ meet you. |
| 6. not too or two | 13. rhymes with fly |
| 7. rhymes with by | 14. body part |



WORD BANK

than your to are
sweet sweeter How
my honey mouth
words to taste, my

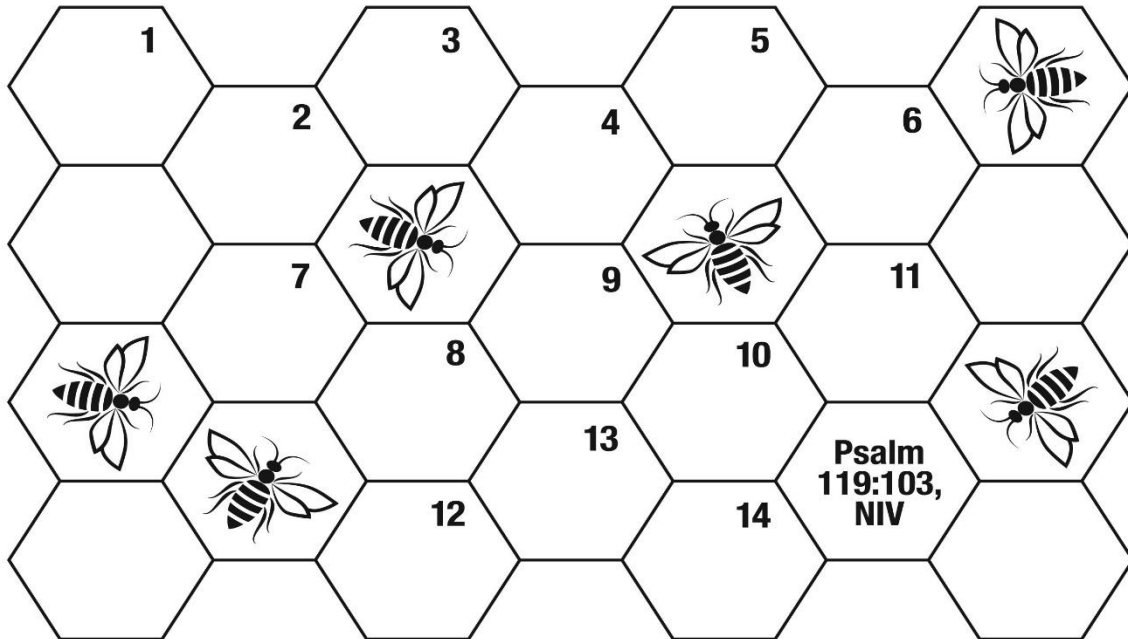

Answer: How sweet are your words to my taste, sweeter than honey to my mouth! Psalm 119:103, NIV