

Kitchen Exhaust Air Cleaning Systems

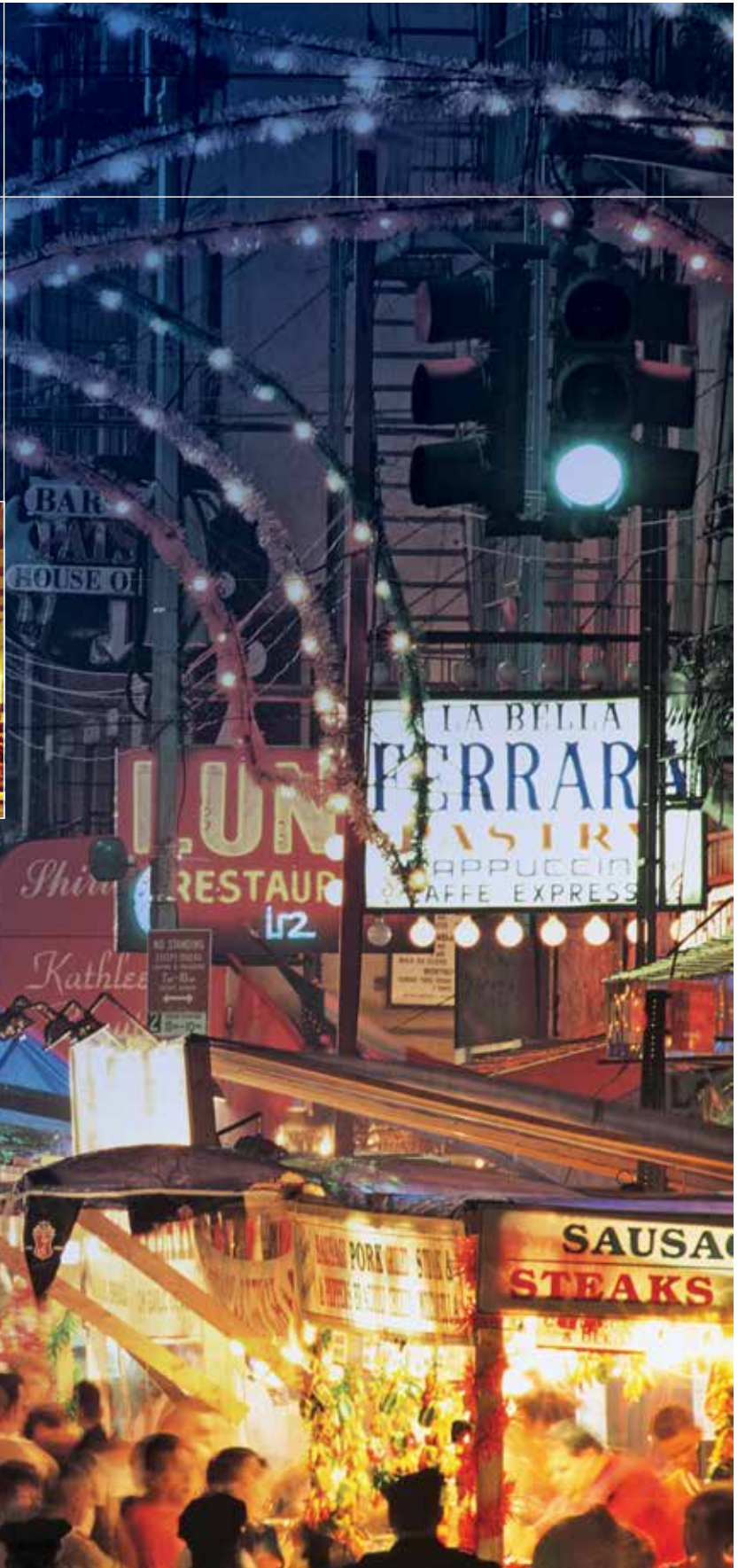

**AIR QUALITY
ENGINEERING**

Air Quality Engineering, founded in 1973, is proud to offer a continued, superior level of experience in manufacturing complete air filtration systems that provide the highest performance, efficiency, and capacity for the money. Our sales and engineering team's mission is to identify the most cost-effective, high quality solutions for our customers' needs, whether commercial, industrial or residential.



Keeping Pace

In today's busy world, more people are going out to eat. For restaurants this growing trend not only increases traffic and revenues but the kitchen hazards associated with this new volume. As kitchen cooking production grows, restaurants will exhaust more smoke, grease, and odors into the air. Local neighbors may raise concerns about air quality, and restaurants may put their roofs at risk with grease pooling that attacks roof materials.

To help restaurants keep pace, Air Quality Engineering offers its Kitchen Exhaust Air Cleaning Systems. These systems use a proven dual-stage electronic air cleaning technique—electrostatic precipitation—to remove smoke, grease, mist, and other particulates from the air.

Eliminating Emissions

Dual-stage electrostatic precipitators include two parts: the charging and the collecting sections. In the charging section, the incoming smoke, grease, mist, and other particulates pass by ionizer wires which impart a positive electrical charge to these contaminants. The positively charged contaminants are then drawn through the collection section which contains a secondary electrical field with negatively charged aluminum plates. Since opposite charges attract, the positively charged contaminants collect on the negatively charged aluminum plates, removing them from the air-stream.

Electronic Air Cleaning

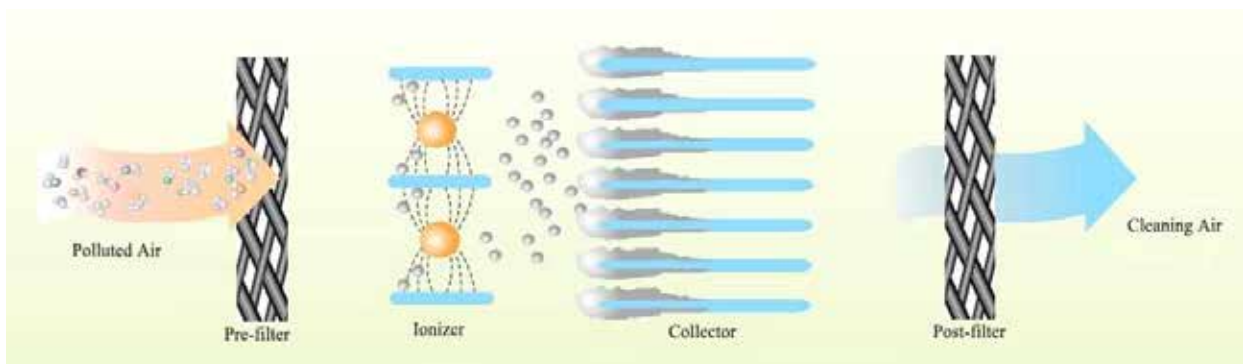



Making a Choice

In order to meet the diverse needs of restaurants, Air Quality Engineering offers two electrostatic precipitator product lines—the AutoClean™ and the F72.

AutoClean™



“ For the ultimate quality and features, choose the AutoClean™—a premier, multi-jet, programmable self-washing system. ”

AutoClean™

- + Self-wash cycle to eliminate filter replacement and electrostatic precipitator cell cleaning
- + Energy efficient units minimize electrical costs
- + Superior quality and construction virtually eliminates maintenance costs
- + Stackable customized modules provide design and installation flexibility for any size installations
- + Up to 99% efficient to ensure clean air
- + Optional carbon filters control odors

SMOKEMASTER® F72



SMOKEMASTER® F72

- + Economical, non-wash system requires no plumbing
- + Available in galvanized or painted finish
- + Side access door for easy maintenance
- + Stackable customized modules provide design and installation flexibility for any size installations
- + Up to 99% efficient to ensure clean air

“ For an easy, economical solution, choose the F72 non-wash system. ”



Specification

Air Volume (CFM)			Efficiency* (%)	Pressure Drop (Inches Water)
AutoClean™ 2000	AutoClean™ 4000	AutoClean™ 8000		
SMOKEMASTER® F72A	SMOKEMASTER® F72B	SMOKEMASTER® F72B Stacked		
1000	2000	4000	99	0.06
1500	3000	6000	99	0.12
2000	4000	8000	95	0.22
2500	5000	10000	90	0.33
3000	6000	12000	80	0.49

* Efficiency Ratings based on ASHRAE Standard 52.1-1992 Method of Testing General Ventilation Air-Cleaning Devices. (See more standard details on page 11.) Additional testing information is available by request.

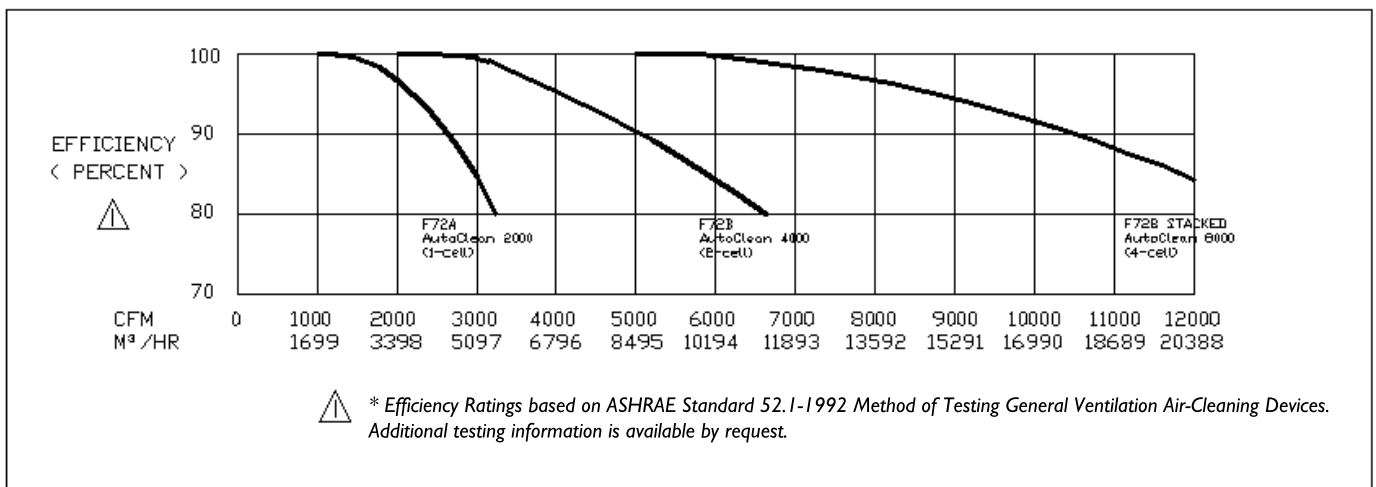

SMOKEMASTER® F72 and AutoClean™ Electronic Air Cleaner Capacity and Efficiency.

Specifications subject to change without notice.

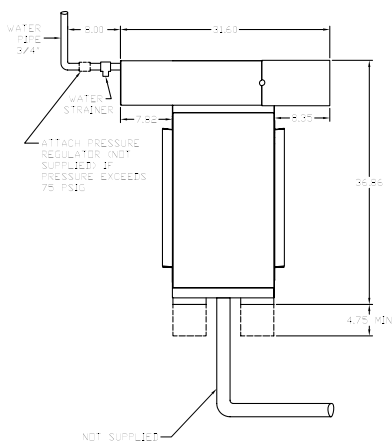
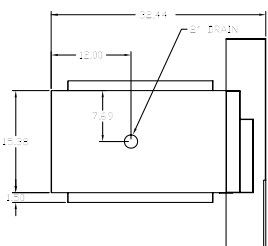
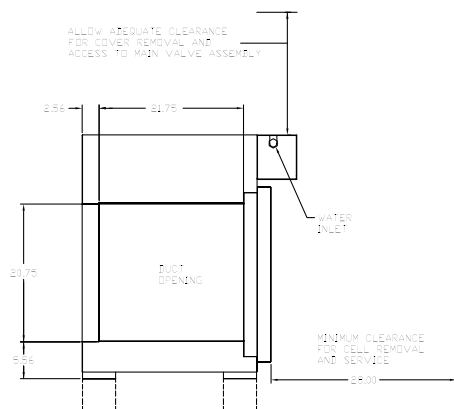

AutoClean™ 2000

Air Volume (CFM)	1,000	1,500	2,000	2,500	3,000
Minimum Efficiency*	99%	99%	95%	90%	80%
Pressure Drop (in.wg.)	0.06	0.12	0.22	0.33	0.49
Dimension	32.44" W x 41.61" H x 31.6" L				
Duct Opening	21.75" W x 20.75" H				
Unit Weight	240 lbs. installed, 290 lbs. shipping				
Cabinet	16 Gauge welded steel cabinet with a powder coat finish				
Power Supply	100% Solid state Input: 120V, 50/60 Hz, 1 Phase or 240V, 50/60 Hz, 1 Phase Output: Ionizer 9,400 VDC / Collector 4,700 VDC				
Ambient Temperature Rating	Air flow through cells: 40 F minimum, 125 F maximum				
Electronic Cell Specification	Cell Dimensions: 24.25" L x 24.25" W x 10.75" D Collection Area: 240 square feet Voltage Gradient: 20000 volts per inch Ionizer Wires: 11 wires per cell, 0.010 inch diameter, tungsten				
Number of Electronic Cells	1 Cell				
Cell Cleaning Method	Programmable Self-Washing System				
Placement Preparation	Hot Water Supply Line: copper pipe 3/4" Waste Drain Minimum clearance for cell removal: 28"				
After filter (Optional) for Odor Control	Activated Carbon Module which are refillable black powder coated steel panels, 10 panels configure in V-Shaped. Activated Carbon weight 9 pounds per panel. Pressure drop is approximately 0.50" wg at 50 fpm.				
Unit Standard	ETL Listed to: UL 867¹ Standard for Electrostatic Air Cleaners UL 710² Standard for Exhaust Hoods for Commercial Cooking Equipment ASHRAE 52.2-2007³ Method of Testing General Ventilation Air-Cleaning Devices for Removal Efficiency by Particle Size				



* Efficiency Ratings based on ASHRAE Standard 52.1-1992 Method of Testing General Ventilation Air-Cleaning Devices. Additional testing information is available by request. (See more standard details on page 11.)

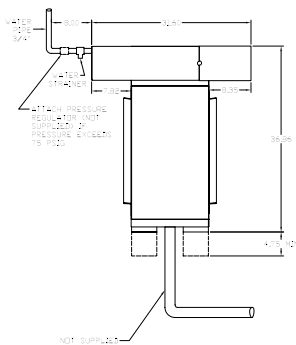
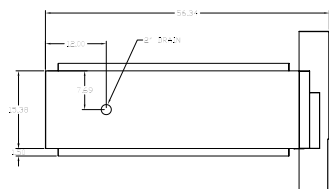
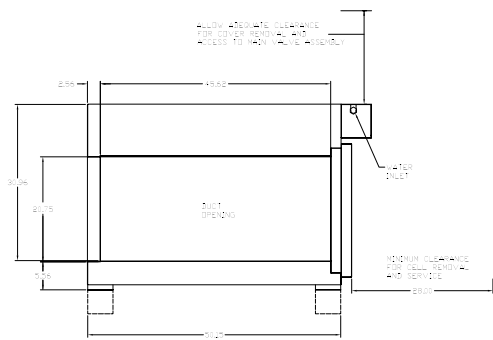

AutoClean™ 4000

Air Volume (CFM)	2,000	3,000	4,000	5,000	6,000
Minimum Efficiency*	99%	99%	95%	90%	80%
Pressure Drop (in.wg.)	0.06	0.12	0.22	0.33	0.49
Dimension	56.34" W x 41.61" H x 31.6" L				
Duct Opening	45.62" W x 20.75" H				
Unit Weight	340 lbs. installed, 390 lbs. shipping				
Cabinet	16 Gauge welded steel cabinet with a powder coat finish				
Power Supply	100% Solid state Input: 120V, 50/60 Hz, 1 Phase or 240V, 50/60 Hz, 1 Phase Output: Ionizer 9,400 VDC / Collector 4,700 VDC				
Ambient Temperature Rating	Air flow through cells: 40 F minimum, 125 F maximum				
Electronic Cell Specification	Cell Dimensions: 24.25" L x 24.25" W x 10.75" D Collection Area: 240 square feet Voltage Gradient: 20000 volts per inch Ionizer Wires: 11 wires per cell, 0.010 inch diameter tungsten				
Number of Electronic Cells	2 Cells				
Cell Cleaning Method	Programmable Self-Washing System				
Placement Preparation	Hot Water Supply Line: copper pipe 3/4" Waste Drain Minimum clearance: 28"				
After filter (Optional) for Odor Control	Activated Carbon Module which are refillable black powder coated steel panels, 20 panels configure in V-Shaped. Activated Carbon weight is 9 pounds per panel. Pressure drop is approximately 0.25" wg at 50 fpm.				
Unit Standard	ETL Listed to: UL 867¹ Standard for Electrostatic Air Cleaners UL 710² Standard for Exhaust Hoods for Commercial Cooking Equipment ASHRAE 52.2-2007³ Method of Testing General Ventilation Air-Cleaning Devices for Removal Efficiency by Particle Size				



* Efficiency Ratings based on ASHRAE Standard 52.1-1992 Method of Testing General Ventilation Air-Cleaning Devices. Additional testing information is available by request. (See more standard details on page 11.)

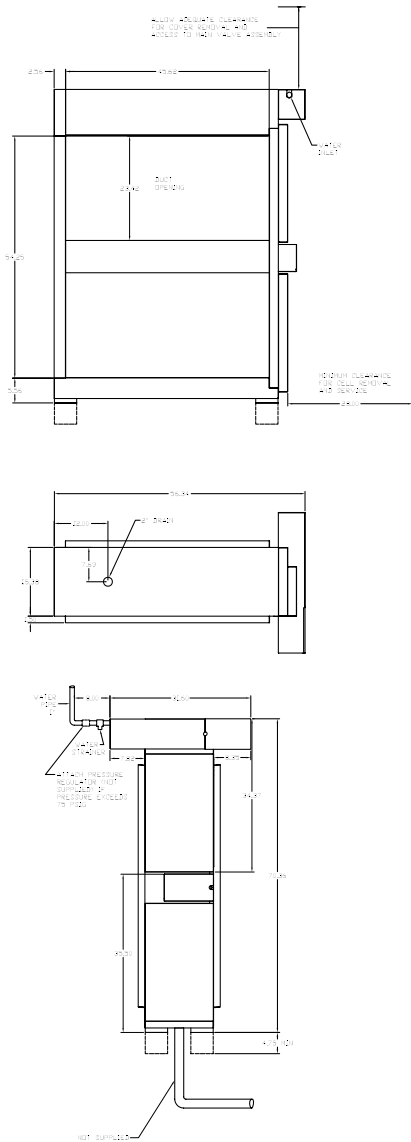

AutoClean™ 8000

Air Volume (CFM)	4,000	6,000	8,000	10,000	12,000
Minimum Efficiency*	99%	99%	95%	90%	80%
Pressure Drop (in.wg.)	0.06	0.12	0.22	0.33	0.49
Dimension	56.34" W x 75.11" H x 31.6" L				
Duct Opening	45.62" W x 54.25" H				
Unit Weight	530 lbs. installed, 600 lbs. shipping				
Cabinet	16 Gauge welded steel cabinet with a powder coat finish				
Power Supply	100% Solid state Input: 120V, 50/60 Hz, 1 Phase or 240V, 50/60 Hz, 1 Phase Output: Ionizer 9,400 VDC / Collector 4,700 VDC				
Ambient Temperature Rating	Air flow through cells: 40 F minimum, 125 F maximum				
Electronic Cell Specification	Cell Dimensions: 24.25" L x 24.25" W x 10.75" D Collection Area: 240 square feet Voltage Gradient: 20000 volts per inch Ionizer Wires: 11 wires per cell, 0.010 inch diameter tungsten				
Number of Electronic Cells	4 Cells				
Cell Cleaning Method	Programmable Self-Washing System				
Placement Preparation	Hot Water Supply Line: copper pipe 1" Waste Drain Minimum clearance for cell removal: 28"				
After filter (Optional) for Odor Control	Activated Carbon Module which are refillable black powder coated steel panels, 40 panels configure in V-Shaped. Activated Carbon weight 9 pounds per panel. Pressure drop is approximately 0.25" wg at 50 fpm.				
Unit Standard	ETL Listed to: UL 867¹ Standard for Electrostatic Air Cleaners UL 710² Standard for Exhaust Hoods for Commercial Cooking Equipment ASHRAE 52.2-2007³ Method of Testing General Ventilation Air-Cleaning Devices for Removal Efficiency by Particle Size				



* Efficiency Ratings based on ASHRAE Standard 52.1-1992 Method of Testing General Ventilation Air-Cleaning Devices. Additional testing information is available by request. (See more standard details on page 11.)

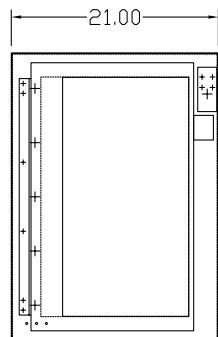
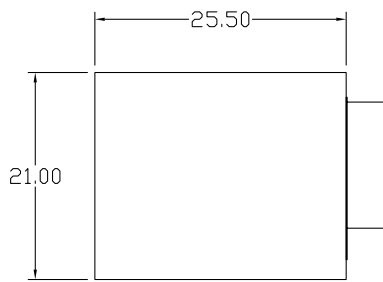
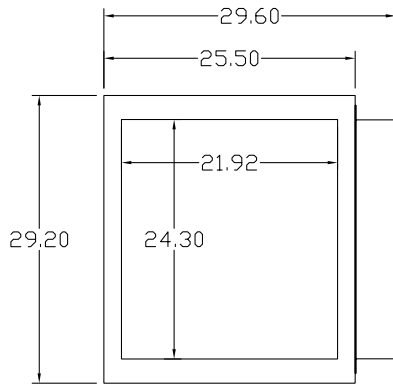

SMOKEMASTER® F72A

Air Volume (CFM)	1,000	1,500	2,000	2,500	3,000
Minimum Efficiency*	99%	99%	95%	90%	80%
Pressure Drop (in.wg.)	0.06	0.12	0.22	0.33	0.49
Dimension	21.00" L x 25.50" W x 30.39" H (Height includes mounting)				
Duct Opening	21.92" W x 24.30" H				
Unit Weight	150 lbs. Installed, 185 lbs. Shipping				
Cabinet	16 Gauge galvanized-steel, hinged-filter access door Optional: Powder Coated Paint				
Power Supply	100% Solid state Input: 120V, 50/60 Hz, 1 Phase or 240V, 50/60 Hz, 1 Phase Output: Ionizer 9,400 VDC / Collector 4,700 VDC				
Ambient Temperature Rating	Air flow through cells: 40° F Min, 125° F Max				
Electronic Cell Specification	Cell Dimensions: 24.25" x 24.25" x 10.75" Collection Area: 240 Ft ² Voltage Gradient: 20,000 volts per inch min. Ionizer Wires: 11 wires per cell, .01" diameter, tungsten Weight: 60lbs. Per cell				
Number of Electronic Cells	1 Cell				
Cell Cleaning Method	Manual Wash				
Placement Preparation	28.00" minimum clearance for cell removal and service				
Pre/Post Filters	1" thick				
After filter (Optional) for Odor Control	Activated Carbon Module which are refillable black powder coated steel panels, 10 panels configured in V-Shape. Activated Carbon weight 9 lbs. in each panel. Pressure drop is .5" w.c. at 50 fpm				
Unit Standard	ETL Listed to: UL 867¹ Standard for Electrostatic Air Cleaners UL 710² Standard for Exhaust Hoods for Commercial Cooking Equipment ASHRAE 52.2-2007³ Method of Testing General Ventilation Air-Cleaning Devices for Removal Efficiency by Particle Size				

* Efficiency Ratings based on ASHRAE Standard 52.1-1992 Method of Testing General Ventilation Air-Cleaning Devices. Additional testing information is available by request. (See more standard details on page 11.)

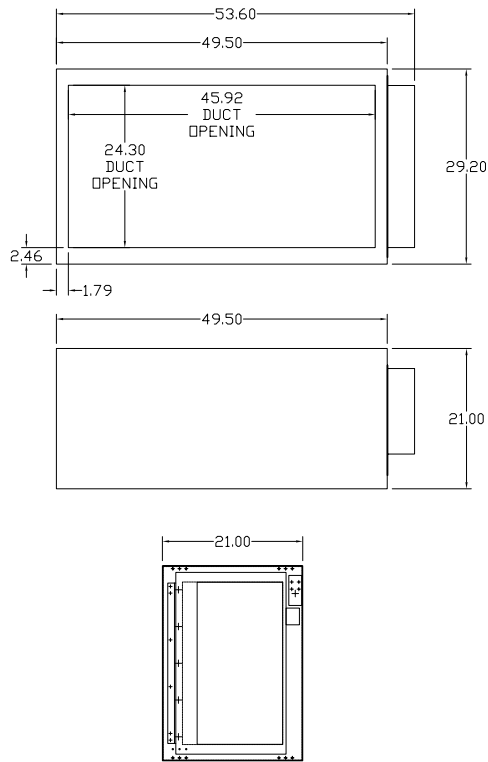

SMOKEMASTER® F72B

Air Volume (CFM)	2,000	3,000	4,000	5,000	6,000
Minimum Efficiency*	99%	99%	95%	90%	80%
Pressure Drop (in.wg.)	0.06	0.12	0.22	0.33	0.49
Dimension	21.00" L x 49.50" W x 30.39" H (Height includes mounting)				
Duct Opening	45.92" W x 24.30" H				
Unit Weight	250 lbs. Installed, 310 lbs. Shipping				
Cabinet	16 Gauge galvanized-steel, hinged-filter access door Optional: Powder Coated Paint				
Power Supply	100% Solid state Input: 120V, 50/60 Hz, 1 Phase or 240V, 50/60 Hz, 1 Phase Output: Ionizer 9,400 VDC / Collector 4,700 VDC				
Ambient Temperature Rating	Air flow through cells: 40° F Min, 125° F Max				
Electronic Cell Specification	Cell Dimensions: 24.25" x 24.25" x 10.75" Collection Area: 240 Ft ² Voltage Gradient: 20,000 volts per inch min. Ionizer Wires: 11 wires per cell, .01" diameter, tungsten Weight: 60lbs. Per cell				
Number of Electronic Cells	2 Cells				
Cell Cleaning Method	Manual Wash				
Placement Preparation	28.00" minimum clearance for cell removal and service				
Pre/Post Filters	1" thick				
After filter (Optional) for Odor Control	Activated Carbon Module which are refillable black powder coated steel panels, 20 panels configured in V-Shape. Activated Carbon weight 9 lbs. in each panel. Pressure drop is .5" w.c. at 50 fpm				
Unit Standard	ETL Listed to: UL 867¹ Standard for Electrostatic Air Cleaners UL 710² Standard for Exhaust Hoods for Commercial Cooking Equipment ASHRAE 52.2-2007³ Method of Testing General Ventilation Air-Cleaning Devices for Removal Efficiency by Particle Size				



* Efficiency Ratings based on ASHRAE Standard 52.1-1992 Method of Testing General Ventilation Air-Cleaning Devices. Additional testing information is available by request. (See more standard details on page 11.)



SMOKEMASTER® F72B Stacked

Air Volume (CFM)	4,000	6,000	8,000	10,000	12,000
Minimum Efficiency*	99%	99%	95%	90%	80%
Pressure Drop (in.wg.)	0.06	0.12	0.22	0.33	0.49
Dimension	21.00" L x 49.5" W x 59.59" H (Height includes mounting)				
Duct Opening	Two openings, at 45.38" W x 24.31" H each opening				
Unit Weight	500 lbs. Installed, 620 lbs. Shipping				
Cabinet	16 Gauge galvanized-steel, hinged-filter access door Optional: Powder Coated Paint				
Power Supply	100% Solid state Input: 120V, 50/60 Hz, 1 Phase or 240V, 50/60 Hz, 1 Phase Output: Ionizer 9,400 VDC / Collector 4,700 VDC				
Ambient Temperature Rating	Air flow through cells: 40° F Min, 125° F Max				
Electronic Cell Specification	Cell Dimensions: 24.25" x 24.25" x 10.75" Collection Area: 240 Ft ² Voltage Gradient: 20,000 volts per inch min. Ionizer Wires: 11 wires per cell, .01" diameter tungsten Weight: 60lbs. Per cell				
Number of Electronic Cells	4 Cells				
Cell Cleaning Method	Manual Wash				
Placement Preparation	28.00" minimum clearance for cell removal and service				
Pre/Post Filters	1" thick				
After filter (Optional) for Odor Control	Activated Carbon Module which are refillable black powder coated steel panels, 40 panels configured in V-Shape. Activated Carbon weight 9 lbs. in each panel. Pressure drop is .5" w.c. at 50 fpm				
Unit Standard	ETL Listed to: UL 867¹ Standard for Electrostatic Air Cleaners UL 710² Standard for Exhaust Hoods for Commercial Cooking Equipment ASHRAE 52.2-2007³ Method of Testing General Ventilation Air-Cleaning Devices for Removal Efficiency by Particle Size				

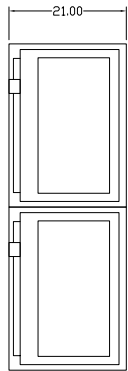
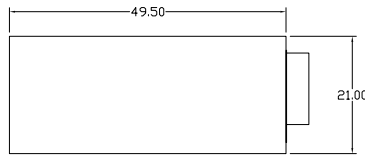
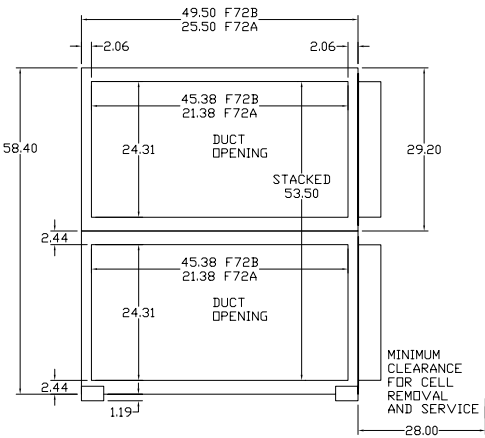

* Efficiency Ratings based on ASHRAE Standard 52.1-1992 Method of Testing General Ventilation Air-Cleaning Devices. Additional testing information is available by request. (See more standard details on page 11.)



ACCESSORIES

Optional Accessories:

- Pre/Post Filter (Aluminum Mesh)
- Carbon Filter (After Filter) with Housing
- Medium Filter in Carbon Module
- Outdoor Housing
- Fans and Motors



Aluminum Mesh (Pre/Post Filter)



Carbon Filter Panel

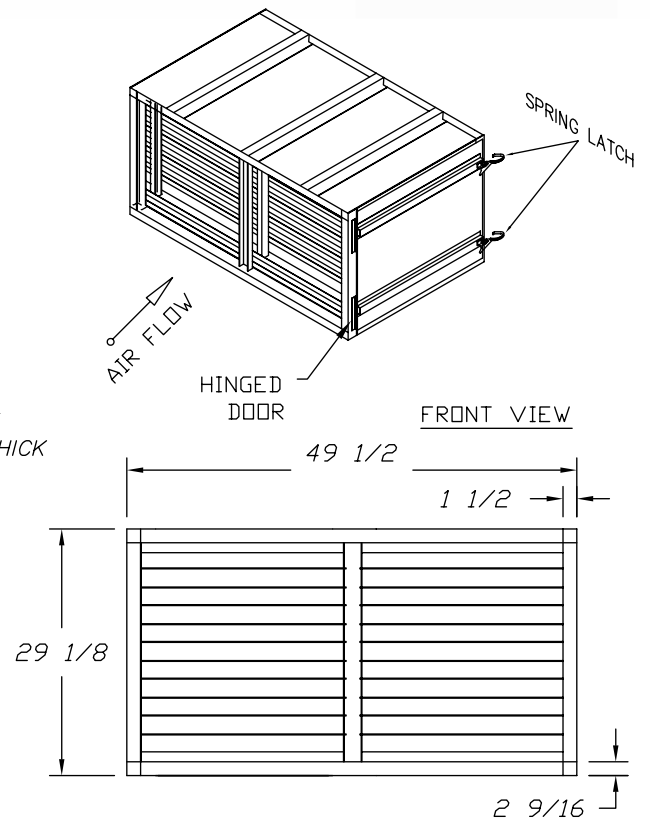
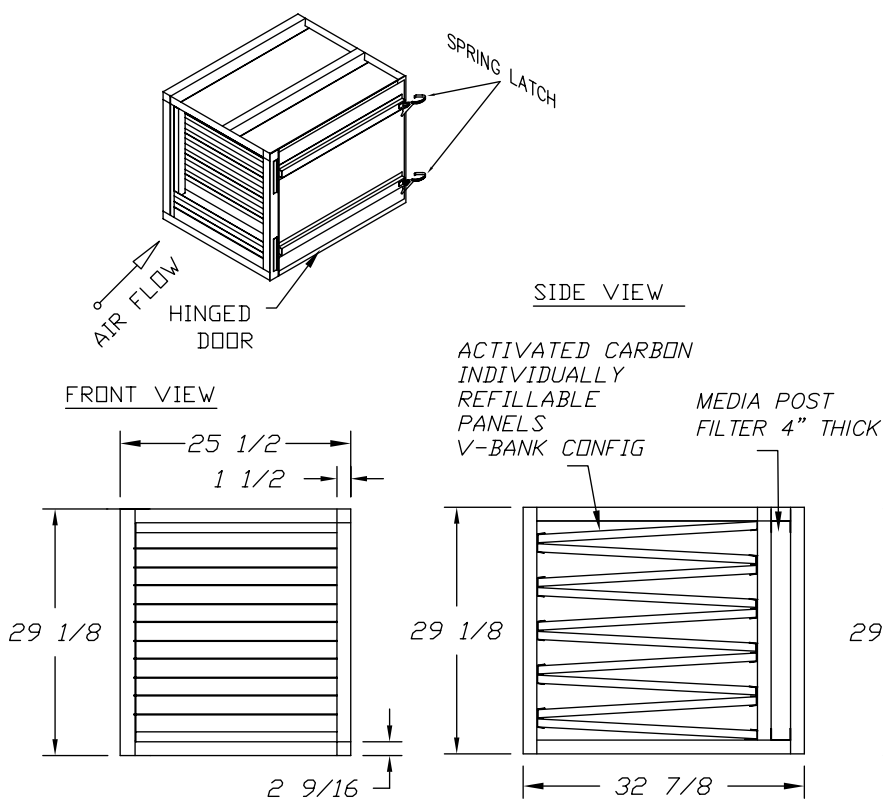

References Standard

ASHRAE Standard 52-76 (1976) ratings have been replaced by ASHRAE Standard 52.1 (1992). These two standards are very similar. In addition, a new standard, **ASHRAE Standard 52.2-2007** ³ **Method of Testing General Ventilation Air-Cleaning Devices for Removal Efficiency by Particle Size**. The filter efficiency ratings are designated by Minimum Efficiency Reporting Value (MERV) between 1 and 20 as shown in the table below.

Table 1: Comparison of ASHRAE Standards 52.1 and 52.2

MERV	U.S. Standards					European Standards	Particle Size Range (µm)	Applications
	ASHRAE 52.2			ASHRAE 52.1		EN779 &		
	Particle Size Range			Test		European Efficiency Class		
	3 to 10 µm	1 to 3 µm	0.3 to 1 µm	Arrestance	Dust Spot			
1	<20%	-	-	<65%	<20%	G1, G2	>10	Residential, light, pollen, dust mites
2	<20%	-	-	65 - 70%	<20%			
3	<20%	-	-	70 - 75%	<20%			
4	<20%	-	-	>75%	<20%			
5	20 - 35%	-	-	80 - 85%	<20%	G3	3.0 - 10	Industrial, dust, molds, spores
6	35 - 50%	-	-	>90%	<20%			
7	50 - 70%	-	-	>90%	20 - 25%	G4, F5		
8	>70%	-	-	>95%	25 - 30%			
9	>85%	<50%	-	>95%	40 - 45%	F5	1.0 - 3.0	Industrial, Legionella, dust
10	>85%	50 - 65%	-	>95%	50 - 55%	F5, F6		
11	>85%	65 - 80%	-	>98%	60 - 65%	F6		
12	>90%	>80%	-	>98%	70 - 75%	F6		
13	>90%	>90%	<75%	>98%	80 - 90%	F6, F7	0.3 - 1.0	Hospitals, smoke removal, bacteria
14	>90%	>90%	75 - 85%	>98%	90 - 95%	F7, F8		
15	>90%	>90%	85 - 95%	>98%	>95%	F8		
16 [*]	>95%	>95%	>95%	>98%	>95%	H11		
17	-	-	≥99.97%	-	-	U13-14	<0.3	Cleansroom, Surgery, chem-bio, viruses
18	-	-	≥99.99%	-	-	U15		
19	-	-	≥99.999%	-	-			
20	-	-	≥99.9999%	-	-			

Note: This table is adapted from Table 5-1, U.S. Federal Emergency Management Agency (FEMA) document 426, Risk Management Series, Reference Manual to Mitigate Potential Terrorist Attacks Against Buildings, December 2003, combined with American Society of Heating, Refrigerating, and Air-conditioning Engineers (ASHRAE) Standard 52.2: Method of Testing General Ventilation Air-cleaning Devices for Removal Efficiency by Particle Size, Atlanta, GA, 1999 and Spengler, J.D., Samet, J.M., and McCarthy, J.F., Indoor air quality Handbook, New York, NY: McGraw-Hill, 2000,

Electrostatic Air Cleaner Specification

1. Equipment Description

- 1.1. The Air Cleaner shall handle the contaminated air from kitchen exhaust hoods containing grease, oil, smoke, fumes, odor and dust particles.
- 1.2. The unit shall be modular in construction and shall have individual sections of pre filter and ionization collector section.
- 1.3. Optional odor absorbing section and additional grease impingement sections are available.
- 1.4. All sections can be enclosed in an optional weather-resistant housing.

2. Equipment specifications

- 2.1. The air cleaning system shall be two stages Penny-type electrostatic precipitator.
- 2.2. A manufacturer shall supply the unit with expertise in design and manufacturing of products specified in this section with a minimum of 30 years of documented experience.
- 2.3. Unit shall comply with UL 867 Standard for Electrostatic Air Cleaners and UL 710 Standard for Exhaust Hoods for Commercial Cooking Equipment or equivalent standards. The units shall be in complete accordance with ASHRAE Standard 52.2-2007 Method of Testing General Ventilation Air-Cleaning Devices for Removal Efficiency by Particle Size.
- 2.4. Ozone Generation concentration shall not exceed 0.05 PPM.
- 2.5. Air cleaner shall be installed under the supervision of manufacturer authorized service technician.

3. Principle of Operation

- 3.1. The pre-filter (aluminum mesh) shall remove large particles.
- 3.2. The electronic filter shall remove the smaller grease and smoke particles.
- 3.3. The principle of operation shall be based on electrostatic precipitation.
- 3.4. The particle shall pass by an ionizing wire, which will induce a positive charge on the particle. The particle then shall pass between closely spaced aluminum plates (fins), which are held at a positive charge and ground.
- 3.5. As the charged particle travels between the two aluminum plates it shall be forced away from the plate held at the identical polarity and drawn towards the grounded plate. Once attached the particle shall remain on the plate until cleaned off during washing.

4. Unit Housing

- 4.1. Housing shall be made of 16 gauge galvanized steel construction. Housing may be made with optionally with epoxy coat finish. Each section shall include single door access, located on one side of the unit. The access door shall be mounted on steel hinges and secured with gasket sealed lever latches allowing for component access and removal. All doors shall be gasket to prevent air and water leakage.
 - 4.2. High voltage contacts on the housing shall be made of phosphor/bronze Enclosure for electrical components shall be included to prevent leaks to the power supply.
-

- 4.3. Unit shall have flanges on the inlet and outlet for connecting ductwork. All drainage piping shall be metal. The contractor should install a drain trap to serve as a vacuum break.
- 4.4. Electrical contacts shall be in the door for ease of maintenance.
- 4.5. Between each section should be sealed with silicone for permanent seal. Each unit shall have track guides for proper alignment of cell, making it possible to change the direction of airflow by reversing the orientation of electronic collector cell(s).
- 4.6. Base Construction, The modules are to be mounted on legs for floor mounting. Ceiling mount brackets are also included for optional ceiling installation.
- 4.7. Finish, the external casing finish shall be a durable industrial grade semi gloss baked on epoxy ester, not less than 3-mil minimum thickness.

5. Pre Filter

- 5.1. Pre filter frame shall be washable aluminum.
- 5.2. Media, Washable Aluminum nominal 1.00 inch (25.4 mm) thick mesh. 9 layers of mesh to optimally remove larger particles of grease and dust before the main filter. Face of each pre filter shall be 4 square feet (1.47 square meters)
- 5.3. Access to the pre filter shall be from the side through the same hinged door to gain access to the electronic cells. Separator section shall be designed for an equal airflow across the entire air cleaning unit.
- 5.4. All liquid particulate removable by the separator shall be collected and drained from the collector system during operation.
- 5.5. Optional additional pre filter sections available.

6. Electronic cells, Electronic cells described in this section refer to a full size cell. Half size cells also can be specified.

- 6.1. Ionizing-Collecting cell shall be of one-piece construction 10.75 inches (273 mm) deep in direction of airflow. Face area of each cell shall be 4.08 square feet (0.38 square meters) and the effective collecting area 240 square feet (22.29 square meters)
- 6.2. Frame, All support framing, end plates and ionizer ground electrodes shall be 0.080- inch (2.03-mm) thick aluminum.
- 6.3. Handle shall be located on the side of the cell for removal of the cell from the air cleaner. The handle shall be grounded to the frame of the cell. Engraving shall be on the handle indicating "this side out".
- 6.4. Contacts shall be made of phosphor bronze on the front of the cell. They shall make contact with the ionizing, collector and ground sections of the cell.
- 6.5. Ionizer section
 - 6.5.1. Ionizing wires shall be minimum of 11 per electronic cell, with a length of 20.32 inches (533.4 mm) each.
 - 6.5.2. Ionizing wires shall be constructed of 0.010 inches diameter (0.25 mm) Tungsten for prevention of corroding or breaking. Wires shall be fixed at one end and spring mounted on the other for ease of maintenance.

6.5.3. There shall be 10 grounding plates between the wires stabilize the ionization field for better performance. Grounding plates shall be no greater than 1.964 inches (49.89 mm) apart, and 0.063 inches (1.6 mm) thick.

6.5.4. Insulators for the Ionizer shall be made of ceramic measuring 1.0 inches (25.4 mm) thick by 2.25 inches (57.15 mm) square with a center hole measuring 0.275 inches (6.95 mm) in diameter. The insulators should have a protective coating of glazing to retard tracking. Insulators shall not number less than 4 in the ionizer section.

6.6. Collector section

6.6.1. Grounding plates shall be a minimum of 0.025 inches (0.635 mm) thick aluminum. The plates shall be 7.64 inches (194 mm) deep in the direction of airflow. Grounding plates shall be a minimum of 54 quantity per cell. Spacing between grounding plates shall be at 0.3678 inches (9.34 mm). Spacing between the grounding plates and the charged plates shall be at 0.1839 inches (4.67 mm).

6.6.2. Charged plates shall be a minimum of 0.025 inches (0.635 mm) thick Aluminum. The plates shall be 7.14 inches (181.36 mm) deep in the direction of airflow. Charged plates shall be a minimum of 55 quantity per cell. Spacing between charged plates shall be at 0.3678 inches (9.34 mm).

6.6.3. Separator rods shall be made of aluminum with notches to hold the ground and charged plates apart at given lengths. Rods shall be 0.25 inches (6.35 mm) in diameter. The separator rods shall run the length of the cell to the frame of the cell. There shall be at least 11 rods total per cell.

6.6.4. Insulators for the collector shall be made of ceramic measuring 0.8 inches (20.32 mm) thick by 2.25 inches (57.15 mm) square with a center hole measuring 0.275 inches (6.99 mm) in diameter. The insulators should have a protective coating of glazing to retard tracking. Insulators shall not number less than 10. Insulator shall be out of the air stream.

6.6.5. Markings shall be on the cell to inform clean weight of the cell. Engraving shall be on the cell indicating direction of the airflow.

7. Power Supply

7.1. Power supply shall be of a 100% solid state type.

7.2. Power supply shall be mounted within the air cleaner out of the air stream.

7.3. Voltages

7.3.1. Input voltage shall be 120 VAC, 60 HZ, 1 phase.

7.3.2. Output High frequency with built in short circuit and arc protection, providing a dual high voltage output of (+) 9.4 KVDC for the ionizer and (+) 4.7 KVDC for the collector.

7.4. The power supply shall operate over a temperature range of -20 to 140 °F (-38 to 85 °C).

7.5. Be self-protecting.

7.6. Accommodate a neon light indicating the performance status.

8. **Interlock switches**, Location –Integrally grounded, door operated electrical safety interlock switch shall be provided to prevent access to the high voltage collector cells without first interrupting the primary input power.

9. **12 Month Limited Parts Warranty is included.**

Odor Neutralizer

1. Equipment Description

- 1.1. The Odor Neutralizer shall be used to handle the contaminated air from kitchen exhaust hoods containing gases and vapors (odors)
- 1.2. The unit shall be modular in construction and shall go inline with an Air Quality Engineering model F72A or F72B air cleaner.

2. Equipment Specifications

- 2.1. The Odor Neutralizer shall be an Air Quality Engineering Carbon Module.
- 2.2. A manufacturer shall supply the unit with expertise in design and manufacturing of products specified in this section.
- 2.3. Odor Neutralizer shall be installed under the supervision of an Air Quality Engineering employee or Air Quality Engineering authorized service technician.

3. Principle of Operation

- 3.1. The principle of operation shall be based on Adsorption in the airstream. Adsorption is the process where a gas is taken to a porous substance and held there.
- 3.2. Activated Carbon is used only to adsorb materials that are in the gaseous or vaporized state. Materials that cannot be removed by particulate filters.
- 3.3. Gases and vapors travel through the carbon filter and are adsorbed into the micro-pore structure of the carbon.

4. Carbon Media

- 4.1. Carbon
 - 4.1.1. Base material shall be of Coconut Shell allowing for high affinity over a wide variety of high molecular weight organic compounds.
 - 4.1.2. Particle size shall be 4 x 8 allowing for a range of adsorbent retention.
 - 4.1.3. Carbon Tetrachloride Activity shall initially be at 60 minimum.
 - 4.1.4. Hardness number shall be 97 minimum.
 - 4.1.5. Density shall be an average of 31 pounds per cubic foot (497 kg per cubic meter)
 - 4.1.6. Total ash content shall not exceed 2%
 - 4.1.7. Iodine number shall be greater than 1050.
- 4.2. Panels
 - 4.2.1. Panels shall be of a V-bank configuration.
 - 4.2.2. Panels shall be 26 gauge (0.45 mm) black powder coated steel.
 - 4.2.3. Panels shall hold a minimum of 9 pounds (4.08 kg) carbon each. Panels shall measure 23.625 inches (60 cm) by 17.5 inches (44.45 cm). Panels shall be 1-inch (2.54-cm) thick minimum.
 - 4.2.4. Airflow shall not exceed a face velocity of 75 ft per minute (22.86 meters per minute).
 - 4.2.5. Panels shall be refillable.

Reference Manufacturer: Air Quality Engineering



Air Quality Engineering, founded in 1973, is proud to offer a continued, superior level of experience in manufacturing complete air filtration systems that provide the highest performance, efficiency, and capacity for the money. Our sales and engineering team's mission is to identify the most cost-effective, high quality solutions for our customers' needs, whether commercial, industrial or residential.

For more information, please contact:

Air Quality Engineering, Inc.
7140 Northland Drive North
Brooklyn Park, MN 55428-1520
Phone 800.328.0787
FAX 763.531.9900



7140 Northland Drive North, Brooklyn Park, MN 55428-1520, USA
PHONE: 763-531-9823 • **FAX:** 763-531-9900 • **TOLL FREE:** 1-800-328-0787
EMAIL: info@air-quality-eng.com • www.air-quality-eng.com