



**HONEST JOHN
ROCKET**

**One Hundred and Fifty-Eighth
Field Artillery**

Volume No. 16

Edition Number III dated 2 February 2026

John T. Jenson



**For the organizational archives of the
158th Field Artillery Battalion**

Copyright © 2026 by John T. Jenson. All rights reserved. No part of this book may be reproduced in any manner without written permission, except in the case of brief quotations included in critical articles and reviews. For information, please contact the author.

Edition No# III Dated 2 February 2026

Copyright © 2026 by John T. Jenson

U. S. Library of Congress Control Number 2018957292

2nd Battalion 158th Field Artillery



HONEST JOHN ROCKET

Table of Contents

Preface	3
The Pentomic Division	4
The ROAD Division	7
History of the MGR-1 Rocket	10
Honest John Organization	13
The Stationing Plan	21
Roster of Membership 1975	25
Roster of Membership 1976	37



PREFACE

The purpose of this volume is to recognize and honor all the soldiers that served with the 2nd Battalion (Honest John) 158th Field Artillery. From 1975 through 1977, there should have been years of celebration because this battalion was able to transform former signalmen, military police, and truck drivers into a cohesive firing unit; that was able to accurately launch an Honest John Rocket; all within 2 months of its activation. Although triumphant in mastering the system, the Honest John system itself was questioned and subjected to change, and this change forced the battalion to “case its colors”.

THE PENTOMIC DIVISION

The battlefield with its shifts in tactics and modern technology has always dictated the reorganization and restructuring of the United States Army and the Oklahoma National Guard. The National Defense Act of 1918 authorized two infantry regiments of National Guard to the State of Oklahoma. Then in 1920 the National Defense Act created the 45th Infantry Division consisting of National Guard soldiers from Oklahoma, Colorado, New Mexico, and Arizona. The two Oklahoma infantry regiments created in 1918 became the 179th and 180th Infantry Regiments of the 90th Brigade, 45th Division. The 157th and 158th Infantry Regiments were assigned to Colorado and Arizona respectively, forming the 89th Infantry Brigade.

These two infantry brigades were the nucleus of the original square division. In 1940 the 45th Infantry Division went on active federal duty as a “square” or four infantry regiment division, backed by supporting artillery regiments and other arms and services. But while at Camp Barkeley, Texas the division was triangularized, in effect, three infantry regiments, the 157th, 179th, and the 180th with fire support, aided by other service units. On the 6th and 9th August 1945 the United States detonated atomic bombs over the Japanese cities of Hiroshima creating the “Atomic Battlefield” and the dawn of the atomic age.

By the 1950's the Army introduced the Pentomic Division concept, consisting of five battle groups that could be dispersed onto the new atomic battlefields, which would be created by the “Cold War Era”. Instead of three basic infantry regiments with their support, there are five battle groups consisting of infantry with a corresponding number of artillery battle groups in direct support of the infantry and more fire power

in rocket and other heavier artillery in general support. Any future battle area will have greater depth and breadth than ever before, dispersion of units will be more necessary than ever to avoid presenting large targets to an enemy, so units must be smaller, and more self-contained. Strength of the new Pentomic Division will be 13,748, contrasted to 17,460 of the triangular division.



Each of the five infantry battle groups is a self-contained unit, each group having a headquarters company, five rifle companies and a combat support company. Headquarters companies have their own administration, communications, engineer and supply support, with organizational motor maintenance, local security for the command post and medical service. The support company has ground radar and reconnaissance, assault weapons and heavy mortar support and counter-fire measures. A tank battalion, in five companies, and five companies of engineers are attached to the infantry battle groups. The new artillery concept is made of six battalions. Five of them are howitzers for direct

support and the sixth is heavy howitzers or rockets which can use either atomic or conventional warheads.

In 1950, the first National Guard unit to go into the “Korean line”, was the 45th Infantry Division however it had never been restructured, it was still a triangular unit. During the Korean War the Army seized the opportunity to standardize its “tactical” nuclear weapon arsenals and doctrine. It developed doctrine that was based from battles fought during the Korean War when the Chinese army used “human-wave attacks”, overwhelming US soldiers. This created a need for a larger magnitude of artillery fire support or a new way to offset numerical superiority. This was best done with tactical, low yield nuclear weapons with “dual-capable” howitzer or rocket artillery battalions that could carry either a conventional or nuclear payload.

On 1 May 1959 the 45th Infantry Division started its restructuring, first by consolidating and redesignating Headquarters and Headquarters Battery, 45th Division Artillery at Enid, Oklahoma and with six battalions at:

1st Howitzer Battalion 158th Artillery at Chickasha, Pauls Valley, and Duncan, Oklahoma.

2nd Howitzer Battalion 158th Artillery at Weatherford, Anadarko, and Minco, Oklahoma.

1st Howitzer Battalion 160th Artillery at Chandler, Tulsa, and Haskell, Oklahoma.

2nd Howitzer Battalion 160th Artillery at Hominy, Pawhuska and Nowata, Oklahoma.

1st Rocket Howitzer Battalion 189th Artillery at Woodward, Alva and Cherokee, Oklahoma.

2nd Howitzer Battalion 189th Artillery at Enid, Tonkawa, and Blackwell, Oklahoma.



No sooner as restructuring started, it was realized by the US Army that these battle groups would be too “light” for conventional warfare and after four years of experiments, the Pentomic Division concept was scrubbed. Despite the failure, the Army continued to develop nuclear doctrine and techniques creating offensive and defensive doctrinal concepts to fight and ward off any attacks in this new atomic/nuclear battlefield. All of these concepts centered on the idea of using low yield tactical nuclear weapons against a conventionally armed foe.

THE ROAD DIVISION

In 1961, President John F. Kennedy directed his Secretary of Defense to undertake a reorganization and modernization of the Army's divisional structure by increasing its non-nuclear firepower, improving its tactical mobility in any environment and increasing its flexibility to respond to any threat. To meet these new challenges the Army abandoned its “Pentomic” structures and eventually redesigned the division with a

standard divisional base and interchangeable maneuver elements. The first new organizational model, Modern Mobile Army (MOMAR) 1965 called for heavy and medium divisions where very man and every piece of equipment in both divisions would be carried and/or mounted on vehicles.

This limited their flexibility, so a new study called the Reorganization Objective Army Divisions (ROAD), was submitted and approved. ROAD did not address the general reorganization of the Army; it called a common divisional base and assigning varying numbers of "maneuver" elements to it. The base for every ROAD division would consist of a headquarters element, which included the division commander and two assistant division commanders; three brigade headquarters; a military police company; aviation, engineer, and signal battalions; a reconnaissance squadron with an air and three ground troops; division artillery; and a support command. The division artillery included three 105mm howitzer battalions, an Honest John (HJ) rocket battalion, and a composite battalion (one 8-inch and three 155-mm howitzer batteries). All artillery was self-propelled. The division artillery commander, however, was reduced from a brigadier general to a colonel. The designers of ROAD determined that an infantry battalion was more appropriate than a battle group as the main building block of the infantry division.

On 13 April 1961, Army approved the ROAD concept, substituting towed artillery for self-propelled artillery, eliminating the 155-mm howitzers, and reorganizing the rocket battalion so that it would include both an HJ rocket and two 8-inch howitzer batteries. Within a few months the Army Command published draft Tables of Organization and Equipment (TO&E) tables and soon the Army Staff began planning for the ROAD reorganization for the summer of 1962. On 1 April 1963 the structure of the 45th Infantry Division was reorganized as a ROAD Division.

On 1 February 1968, the 45th Infantry Division was ordered inactivated and on that date in its place the 45th Infantry Brigade was organized. The 45th Division Artillery was reorganized as Corps Artillery and redesignated as Headquarters and Headquarters Battery, 45th Artillery Group, and relieved from assignment to the 45th Infantry Division and Brigadier General William L. Youell was placed in command. On 1 May 1972 the Headquarters and Headquarters Battery, 45th Artillery Group was redesignated as Headquarters and Headquarters Battery, 45th Field Artillery Group.

Further reorganizations of the Oklahoma Army National Guard occurred on 1 December 1971 and on 1 May 1975, the latter creating the 1st and 2nd Battalions of the 158th Field Artillery. The 1st Battalion (8") (Self Propelled) 158th Field Artillery with Headquarters and Headquarters Battery stationed at Lawton, Battery "A" at Anadarko, Battery "B" at Duncan, Battery "C" at Chickasha and Service Battery at Lawton, Oklahoma with Lieutenant Colonel Merrill B. Burruss as the Battalion Commander and the 2nd Battalion (Honest John) 158th Field Artillery with Headquarters and Service Battery at Oklahoma City, Battery "A" at Marlow, Battery "B" at Walters and Battery "C" at Healdton, Oklahoma with Lieutenant Colonel Melford L. Scott as the Battalion Commander.

The atomic threat that the Honest John presented to any enemy force was so great that they were earmarked as "high payoff targets" because they had the ability to go into a forward field position, fire, and move out and once detected the rocket's supersonic speed would protect it from any known counter measures once it had been fired. Between 1952 and 1960 the Army bought almost 8,000 M31 Honest John rockets from Douglas Aircraft. The Honest John, Little John, Corporal, Lacrosse and Redstone were the first generation of these new tactical nuclear field artillery

rockets and even as the Army was fielding these systems the second generation was already being tested.



Eventually these systems would be replaced by the second generation Lance guided missile. The new Lance missile was mobile in all types of terrain, capable of being fired from its own carrier, provided nuclear and conventional fires, and was so simple to operate that it was compared to the occupation of a firing position by a single self-propelled howitzer. The Lance ultimately replaced the Honest John rocket and on 1 April 1977 the 2nd Battalion 158th Field Artillery (HJ) was inactivated and reorganized with its personnel reassigned to other units in the Oklahoma Army National Guard and its rocket systems were turned in for inactivation.

HISTORY OF THE MGR-1 ROCKET

What eventually became the Honest John Rocket began as a Jet Assisted Take Off (JATO) booster for aircraft. Since the JATO had a high thrust level, it was decided that with the addition of fins and a warhead it would

create a large caliber artillery rocket. It was developed at Redstone Arsenal, in Huntsville, Alabama, as solid propellant, free flight, fin-stabilized, 762mm surface-to-surface, and unguided artillery rocket weighing 5,820 pounds in its initial nuclear armed version. Mounted on the back of a truck, the rocket was aimed in much the same way as cannon and then fired up an elevated ramp, igniting small spin rockets as it cleared the end of the ramp. The spin rockets reduce the effects of thrust misalignment by rotating the rocket after it leaves the launcher. The rocket had a range of 15.4 miles with a 20 kiloton nuclear warhead and was also capable of carrying a 1,500-pound conventional warhead.

HONEST JOHN ROCKET

762-mm MGR-1 (M31 SERIES)

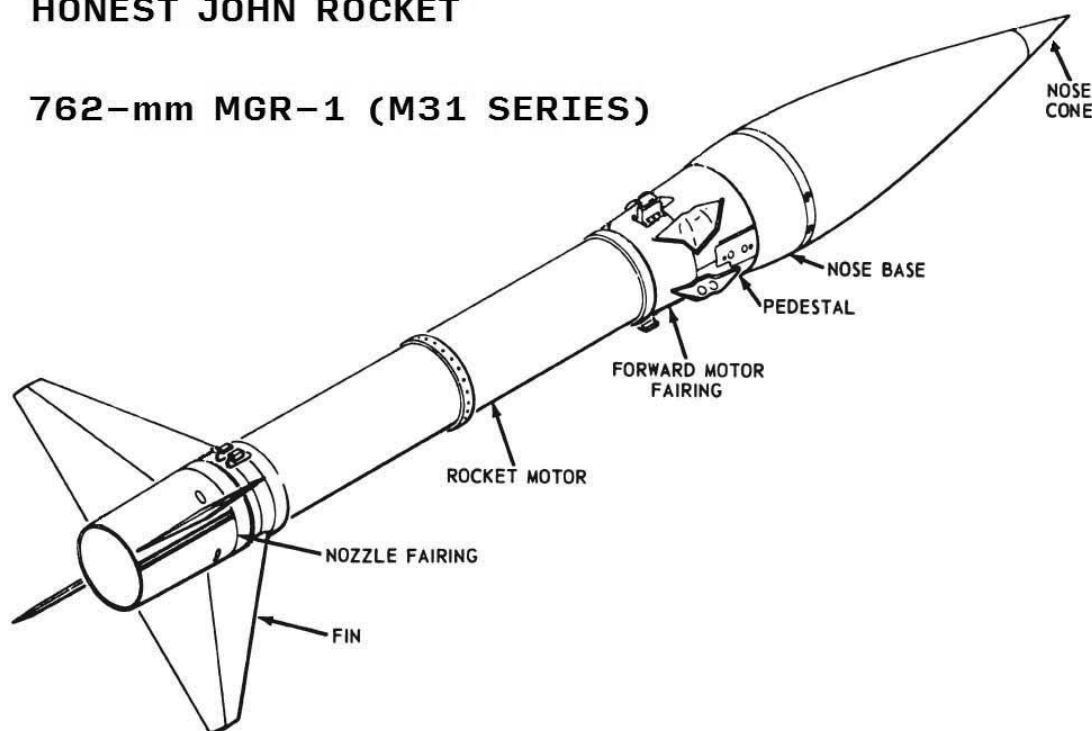

In late 1950's, it was referred to as the "XM31" rocket, until the project manager; Colonel Holger N. Toftoy; was in danger of losing any further funding "on the grounds that such a large unguided rocket had no accuracy". Colonel Toftoy took a trip to White Sands Missile Range, where he met a Texas man who was prone to making unbelievable statements about the accuracy of the rocket. Whenever anyone expressed any doubt or questioned the veracity of the Texan, about the accuracy of the rocket, he defended the accuracy by stating "honest, and around these parts, I'm

called "Honest John!" The nickname became the moniker and namesake of the rocket.

The Honest John was not complicated in its design or operation. It had no electronic controls and required no extensive crew training. The same firing doctrine used in firing conventional artillery was adopted for the Honest John. The absence of any electronic or radio guidance of the Honest John made it impossible for the enemy to alter its course. In cold weather, Honest John rockets were outfitted with a form fitting "electronic blanket" to maintain the specific propellant temperature for launch. Because of its size and simplicity, Honest John had considerably more battlefield mobility than conventional artillery. Just one nuclear warhead carried aboard an Honest John could deliver the destructive power of hundreds of artillery shells.



“HONEST JOHN” ORGANIZATION

Field Manual (FM) 6-59 entitled Field Artillery Rocket Honest John with Launchers M386 and M33 was published to render guidance to commanders when developing their Firing and Assembly and Transport (A&T) sections into efficient teams capable of operating effectively under combat conditions. This manual prescribes general and individual duties of firing section personnel, section drills, tests and adjustments of sighting and fire control equipment, safety precautions, individual duties of assembly and transport section personnel, individual duties of personnel in rocket assembling and testing, and procedures for decontamination and destruction of equipment.

Composition of the Firing Section

The Firing Section consists of a 762mm rocket launcher, a low level wind measuring set (windset), ancillary equipment, and the following personnel:

- (1) Platoon (section) Commander.
- (2) Chief of Section (CS).
- (3) Gunner (G).
- (4) Senior Assembly Specialist (SAS).
- (5) Assembly Specialists (AS).
- (6) Assembly Specialists (AS).
- (7) Launcher Crewman Number 1.
- (8) Launcher Crewman Number 2 (launcher driver).
- (9) Launcher Crewman Number 3.
- (10) Launcher Crewman Number 4.
- (11) Launcher Crewman Number 5.
- (12) Launcher Crewman Number 6 (section truck driver).
- (13) Radio Telephone Operator (RTO) & (light truck driver).

General Duties of Firing Section Personnel

Platoon (Section) Commander: Responsible for the operation of the firing section. Supervises the preparation and execution of fire missions. Supervises the maintenance and operation of section equipment. Supervises the training and directs the tactical employment of the section.

Chief of Section: Noncommissioned officer in command of the section. Responsible to the Platoon Commander for training and efficiency of section personnel. Execution of fire commands by his section. Responsible for performance of duties during section drill, testing and adjustment of sighting and fire control equipment, and inspection and maintenance of all section vehicles and equipment. Determination and application of low level wind corrections. Compliance with safety regulations. Preparation of field fortifications for protection of equipment, rockets, and personnel. Local perimeter security. Camouflage and radiological, biological, and chemical security discipline. Police of section area. Maintenance of launcher records.

Gunner: The gunner is the assistant to the Chief of Section in carrying out the duties specified above. He lays the launcher for deflection and performs duties listed in tables I through VI, FM 6-60.

Senior Assembly Specialist: The senior assembly specialist is responsible for assisting the Chief of Section and the Gunner in carrying out duties specified above. Supervising the handling, checkout, testing, and preparation of the rocket. Performs additional duties as outlined in tables I through VII, FM 6-60.

Assembly Specialists: The assembly specialists are responsible for handling, checkout, testing, and preparation of the rocket motor for firing. Preparation, checkout, and testing of the nuclear warhead. Preparation and fuzing of all warheads. Performing additional duties as prescribed in tables I through VII, FM 6-60.

Launcher Crewmen: Perform the duties listed in tables I through VI, FM 6-60 and any additional duties assigned by the Chief of Section. Launcher Crewmen number 2 drives and performs maintenance on the launcher. He also performs duties as listed in tables I through VII, FM 6-60. Launcher Crewman number 6 drives and performs maintenance on the section truck. He also performs additional duties as prescribed in tables I through VI, FM 6-60. Launcher Crewmen numbers 3, 4, 5, and 6 operate and perform maintenance on the AN/PMQ-6 low level wind equipment, and perform additional duties as prescribed in tables I through VII, FM 6-60. Launcher Crewmen 5 and 6 operate and perform maintenance on the AN/MMQ-1-series low level wind equipment and perform additional duties as prescribed in tables I through VI, FM 6-60.

Radio-Telephone Operator: The radio-telephone operator drives the Section Commander's vehicle, and performs other duties as directed by the Platoon (section) Commander or the Chief of Section.

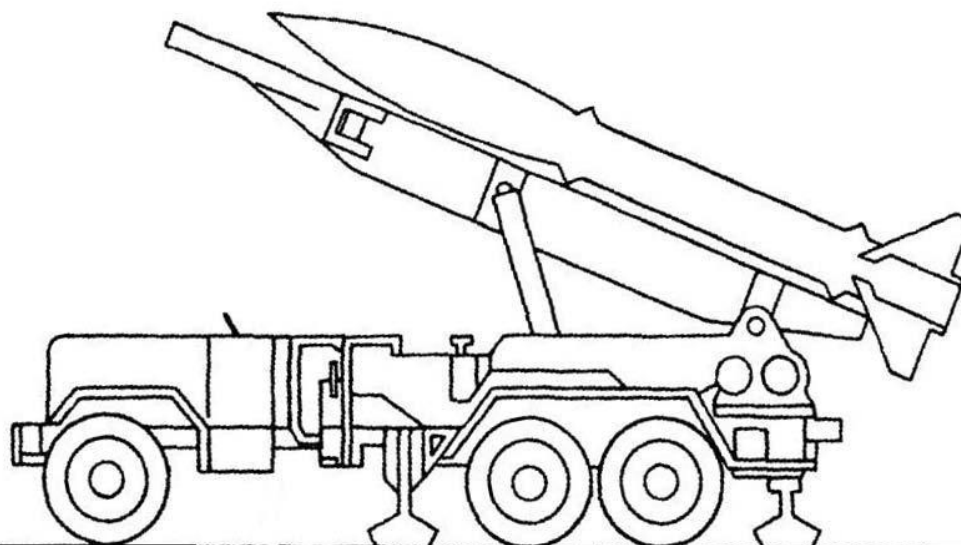

762mm Honest John Rocket

Composition of the Assembly and Transport Section

The Assembly and Transport Section consists of 14 section personnel (a minimum of 6 are required for assembly, using the wrecker, and a

minimum of 9 are required, using the M405 handling unit) and the necessary vehicles and handling equipment required to assembly, test, store, and transport rockets and warheads. The section is capable of testing and assembling two rockets simultaneously for limited periods, and the following personnel:

- (1) Ammunition Officer.
- (2) Chief of Section (CS).
- (3) Senior Assembly Specialists (SAS).
- (4) Senior Assembly Specialists (SAS).
- (5) Assembly Specialists (AS).
- (6) Assembly Specialists (AS).
- (7) Launcher Crewmen.
- (8) Launcher Crewmen.
- (9) Launcher Crewmen.
- (10) Launcher Crewmen.
- (11) Launcher Crewmen.
- (12) Launcher Crewmen.
- (13) Launcher Crewmen.
- (14) Launcher Crewmen.

General Duties of Assembly and Transport Personnel

Ammunition Officer: Responsible for the tactical employment of the section; assembly, and delivery of checked out rockets to the firing sections; storage and security of rocket motors and warheads, and the overall performance of the section.

Chief of Section: Noncommissioned officer in command of the section and is responsible to the Ammunition Officer for the training and efficiency of section personnel. The execution of inspection and maintenance of section equipment, including vehicles, the transportation and handling of rockets from the time of issue at the Special Ammunition Supply Point (SASP) to

the time of delivery to the launcher section, observance of safety precautions, preparation of field fortifications for protection of equipment, rockets, and personnel, camouflage discipline, local security, NBC discipline, and maintenance of prescribed checkout and testing records.

Senior Assembly Specialist: is responsible for the handling, testing, conditioning, checkout, and maintenance of rockets and warheads for delivery to the firing sections.

Assembly Specialists: The assembly specialists assist the Senior Assembly Specialist in the performance of his duties and perform duties listed in FM 6-60, Appendix III and Tables I through XIX and such other duties as prescribed by the Chief of Section.

Launcher Crewmen: All launcher crewmen are drivers. 4 launcher crewmen drive the heating and tie down units, 2 crewmen drive and operate the wreckers, and 2 crewmen are light truck drivers and perform additional duties as prescribed by the Chief of Section.



Support vehicles used with the Honest John platform.

Vehicles and components from left to right: M386 launcher based on the M139 5-ton truck, M62 wrecker/crane, M329 rocket transport trailer, M78A1 truck with mounted heating and tie-down unit and M38A1 (Willys) light utility truck.

Common support vehicles and prime movers used with the Honest John platform may include a configuration of the following:

1. M33 trailer, launcher.
2. M38A1 (Willys) light utility truck.
3. M46 truck, heating and tie down unit.
4. M62 wrecker/crane.
5. M78A1 truck-mounted heating and tie-down unit.
6. M151A1, 1/4-ton, truck.
7. M289 truck, rocket launcher, (M139 truck).
8. M329 trailer, rocket transporter.
9. M386 Truck, short launch rail, 5-ton (M139 truck).
10. M405 handling unit, crane, trailer mounted.
11. M465 cart assembly, transport, 762mm rocket.



M62 Wrecker

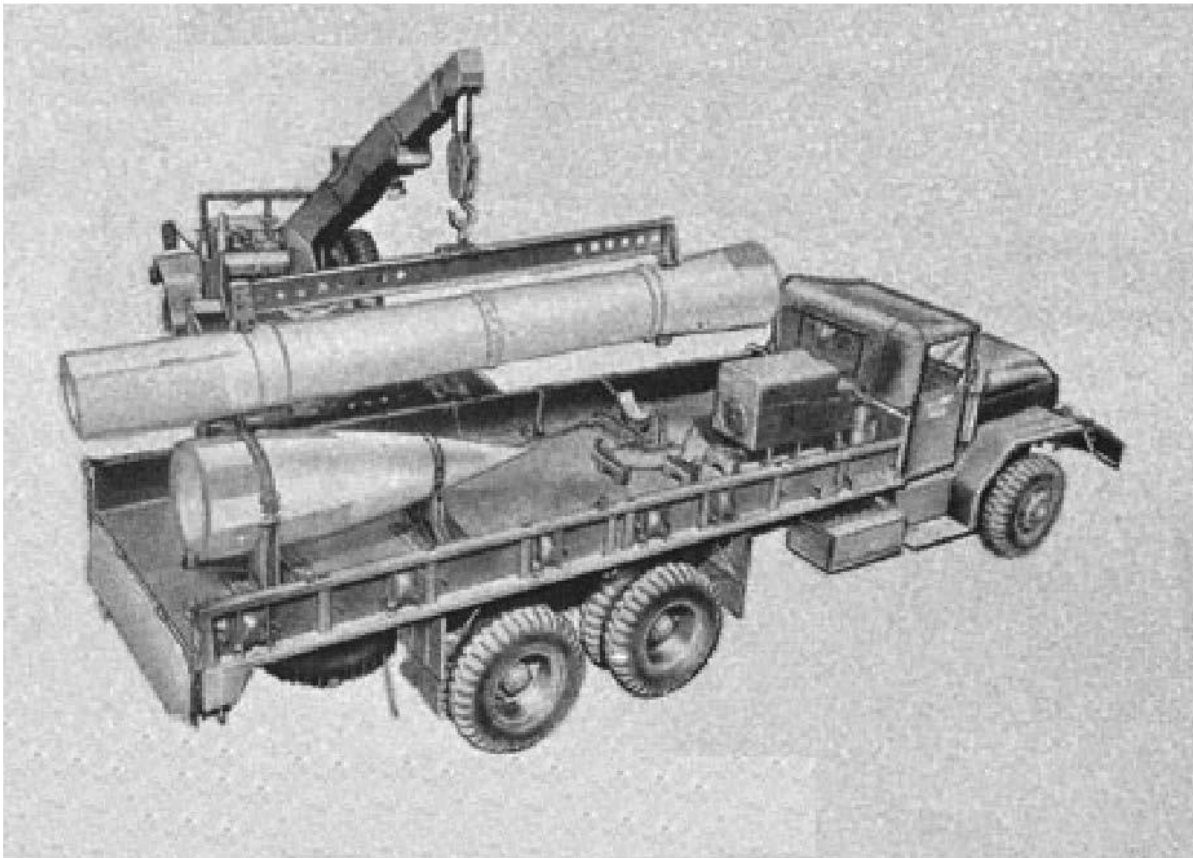

Stage 1

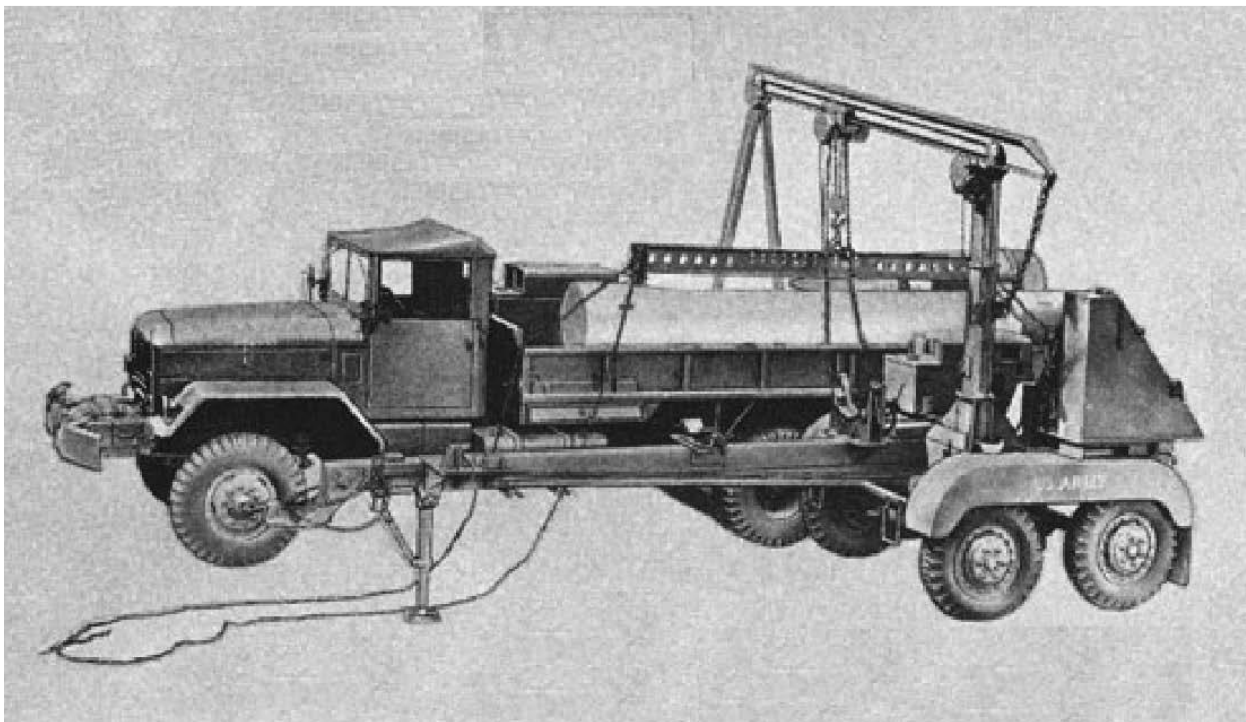

Stage 2

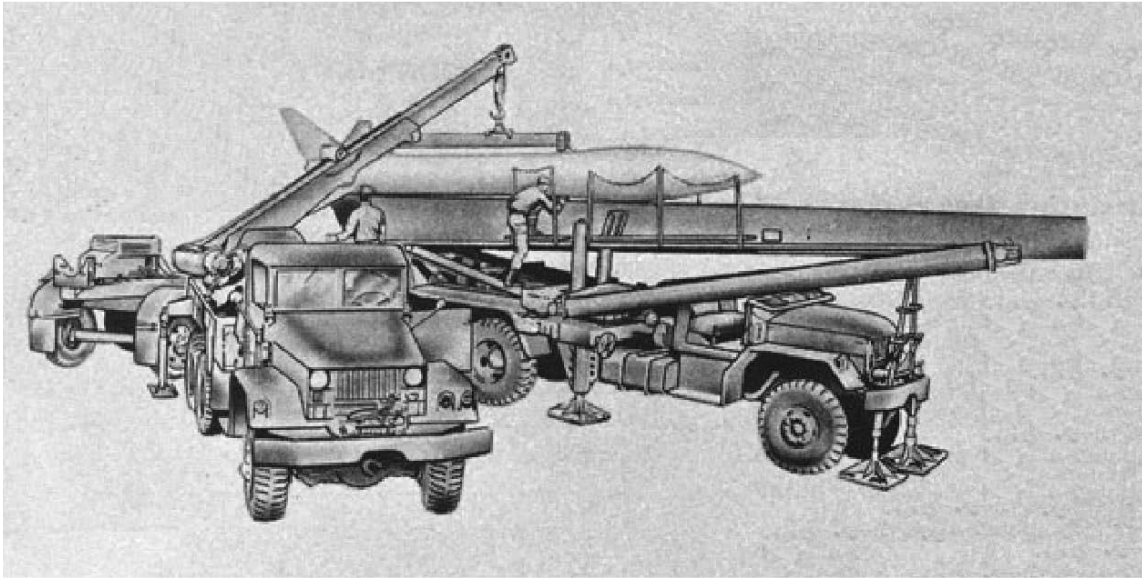

Stage 3

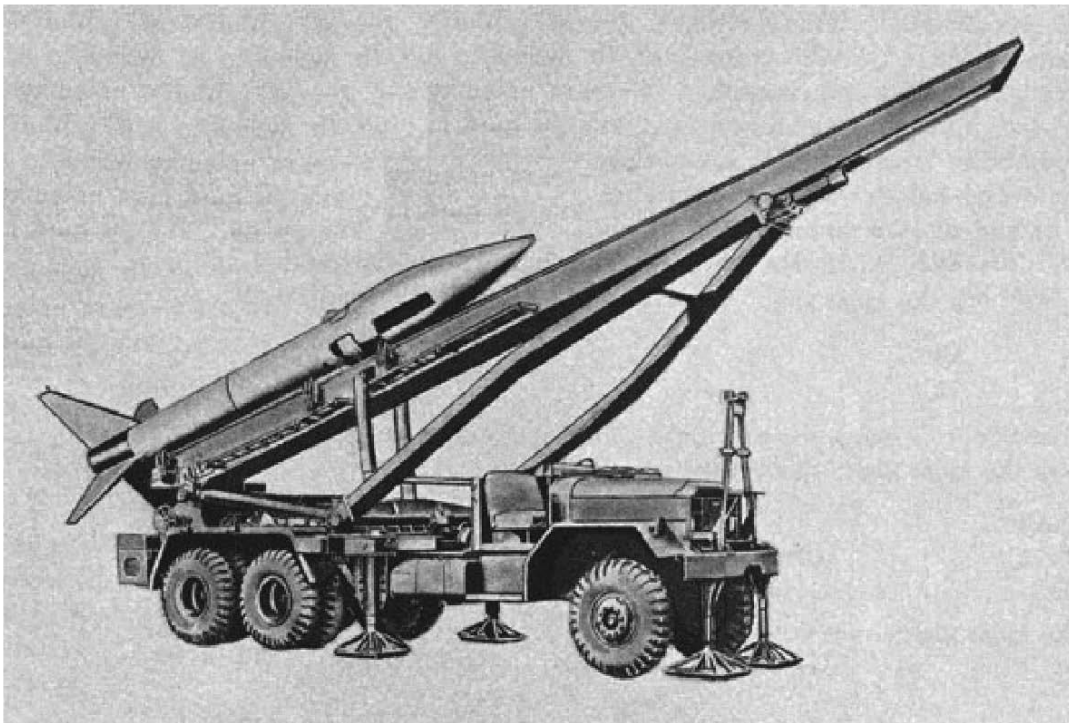

Stage 4

THE STATIONING PLAN

Effective 1 May 1975, General Order Number 105, State of Oklahoma Military Department, dated 30 April 1975, reorganized and redesignated Oklahoma Army National Guard units into the 2nd Battalion (Honest John) 158th Field Artillery Battalion. The following units were reorganized from Oklahoma City, Marlow, Walters and Healdton, Oklahoma.

NEW UNIT	OLD UNIT	LOCATION
HHS Btry 2-158 FA	205 Sig Co	OK City
Btry "A" 2-158 FA	245 MP Co(-Det 1)	Marlow
Btry "B" 2-158 FA	Det 1 245 MP Co	Walters
Btry "C" 2-158 FA	Det 1 1345th Trans Co	Healdton

Authorized strength for HHS Battery is 14 Officers, 3 Warrant Officers and 107 Enlisted Men. Authorized strength for each of the Firing Batteries is 5 Officers and 62 Enlisted Men. Total Strength is 325: 29-O, 3-WO, 293-EM.

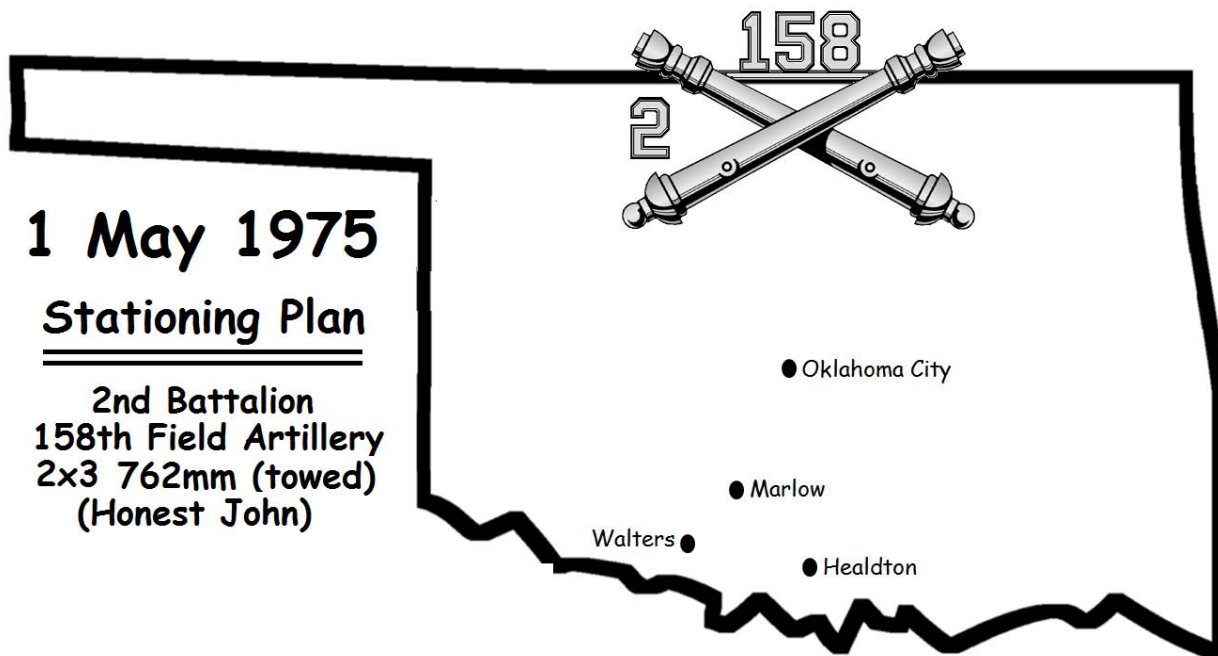

45th Field Artillery Group, commanded by Colonel James M. Bullock Jr. was reorganized with the following units:

HHB 45th Field Artillery Group

1st Bn 158th FA (SP)

1st Bn 171st FA (TA)

1st Bn 189th FA (SP)

2nd Bn 158th FA (HJ)

It must be noted that in 1975 the Active Army, had its doubts that a unit of the Oklahoma Army National Guard could, with accuracy, launch such a complex rocket system. So with the acceptance of this new type of battalion, new training requirements would be placed into effect which would actually enable them to actually conduct a “live-fire” of an Honest John Rocket during their first Annual Training (AT) period, a total of only 2 months after reorganization.

From 12-26 July 1975, AT would be conducted at Fort Chaffee, Arkansas, during the period 12-26 July 1975. The unit was set up in “Tent City”, a field training site constructed for rotating national guard units, performing their AT encampments on Fort Chaffee, since the normal cantonment area was occupied by the Vietnamese Refugee mission. Travel to Fort Chaffee was completed by organic transportation without incident or injury. The battalion immediately rolled up into their new cantonment area which was General Purpose (GP) medium tents on wooden platforms, the latrines was chemical “outhouses” and the “Mess Hall” was a US Army Field Kitchen trailer. Showers were set up in GP tents a short hike from the battery areas. The setup was nice and the upkeep was no problem. After unloading personal gear and equipment, their intensive training began.



Transformation of every member of the battalion was directed into becoming an “Honest John Rocket Artillerymen”, was a new experience for every officer and enlisted man. Battalion level training was focusing on gunnery problem and practical solutions, including manual and M18 Field Artillery Digital Automatic Computer (FADAC) procedures, fundamentals of rocket ballistics, fire direction, standard ballistic meteorological data and miscellaneous gunnery. Battery level training was focused on Firing Section drills, Assembly and Transportation drills, covering all the performance orientated tasks as is outlined in FM 6-60, Appendix III and Tables I through XIX. All personnel worked hard to become proficient in their newly assigned positions, and although the training seemed overwhelming, it all culminated in a 16-hour Tactical Field Training Exercise FTX on Thursday July 24, 1975. It was on this day, in sight of the

large crowd of spectators, including Governor David Boren, that the first rocket was blasted from a rocket launcher. The crowd applauded the tremendous thrust and back blast of the rocket upon ignition and gazed in marvel as its “burn time” fizzled out arching its way towards “Potato Hill” impact area onto its designated target.

The Honest John Rocket weapon system was a valuable addition to the Army’s family of nuclear fire support. It was a tactically acceptable system within the operational capacity required on the battlefield. Its shortcomings was that the weapon system failed to measure up to military standards in respects to its desired maximum and minimum range, delivery accuracy, and operating temperature range. Design refinements were required to make it more suitable for desired performance on the battlefield. But soon the Army Missile Command started favoring the MGM-52 Lance Missile System, for its simple, rugged, and reliable operation in all climatic conditions in which the Army operated in. Production of the Honest John rocket was halted (but not after having produced over 7,000) and the weapon system was placed on a phase-out plan. Conventionally armed Honest Johns remained in the army’s arsenals until they were withdrawn and relegated to Army National Guard units, where in 1982 they were decommissioned. The Honest John’s bulbous nose and distinctive truck mounted launch ramp made it an easily recognized symbol of the Cold War.

The 2nd Battalion (Honest John) 158th Field Artillery Battalion was inactivated on 1 April 1977, and units were reorganized as the 2nd Battalion (TOW) 180th Infantry; a light anti-tank battalion. The 158th Field Artillery was reorganized on 1 April 1977 to consist of only the 1st Battalion.



ROSTER OF MEMBERSHIP 1 JANUARY 1975

2nd Battalion (Honest John)

158th Field Artillery

Headquarters and Headquarters Battery

Oklahoma City, Oklahoma

BATTALION HEADQUARTERS

Battalion Commander	LTC Melford L. Scott
Executive Officer	MAJ Calvin E. Koonce
S-3	CPT Henry D. Thornton
Battalion Surgeon	CPT Robert R. Edde
C-E Staff Officer	1LT John J. Hawk
Liaison Officer	CPT Christopher P. Bills
S-1	CPT Kenneth F. Perry
S-2	1LT Charles P. Jones
S-4	CPT Preston F. Willoughby
Command Sergeant Major	SGM Rudy N. Hightower

BATTERY HEADQUARTERS

Battery Commander	CPT Gary D. Maynard
-------------------	---------------------

First Sergeant	MSG Bobby G. Pierce
Dining Facility Manager	SFC Wallace R. Hall
First Cook	SP5 Gerald W. Robinson
First Cook	SP4 Kenneth R. Pickard
First Cook	SP4 Ronald Fletcher
Cook	PFC Tony L. Mullins
Wheel Vehicle Mechanic	SSG William F. Seiter
Equipment Maintenance Clerk	SP4 Roy L. Waldroop
Power Generator Mechanic	SP5 J. B. Cooper
Wheel Vehicle Mechanic	SP4 Anthony E. West
Wheel Vehicle Mechanic	SP4 Matthew A. Davis
Power Generator Equipment Helper	SP4 Gerald W. Williams
Supply Sergeant	SGT Edgar Y. Ragle
Armorer	SP4 Warner P. Bentley
Unit Clerk	SP5 Edgar D. Quaid
Light Vehicle Driver	SP4 Charles A. Gasaway
Light Vehicle Driver	PVT Clifford N. Townley

HEADQUARTERS SUPPORT SECTION

Personnel Staff NCO	SFC John C. Gibson
Legal Clerk	SP5 Alfred N. Blakely
Clerk Typist	SP4 Kenneth I. Stone

UNIT PERSONNEL SECTION

Unit Personnel Technician	CW2 Loyd Todd Jr.
Personnel Management Specialist	SP5 Gary P. Bates
Personal Records Specialist	PVT Larry D. Tempson
Personnel Actions Specialist	PVT Jackson J. Ross
Finance Specialist	SP4 David J. Jones
Finance Specialist	SP4 Thomas W. Duncan

OPERATIONS AND FIRE DIRECTION CENTER SECTION

Fire Direction Officer	CPT Vincent J. Scalice
Operations Sergeant	SFC George C. Roper
Chief Fire Direction Computer	SFC Jean R. Herring
Assistant Chief Fire Computer	SGT Donald Watson
Fire Direction Computer	SP5 Walter M. Stoyoski
Fire Direction Computer	SP5 Randolph M. Baker
Fire Direction Computer	SP5 Gary L. Maxon
Clerk Typist	SSG Richard D. Mutz
Clerk Typist	SP4 Edward A. Beson

SURVEY SECTION

Chief Surveyor	SFC Elmer C. Kelley
Chief of Survey Party	SP5 Elbert B. Rouse
Survey Computer	SGT Randolph A. Knight
Instrument Operator	SP4 Uley R. Jones Jr.
Survey Recorder	SP4 Corey L. Nimsey
Survey Computer	SP4 Don L. Litle
Survey Computer	PVT Jeffrey L. Honrbeck
Instrument Operator	SP4 Grady L. Sullivan
Survey Recorder	SP4 William G. Schmite
Rodman-Tapeman	SP4 R. J. Akins
Chief of Survey Party	SGT Jimmie L. Wells
Survey Computer	SGT Johnnie L. Turnage
Survey Computer	SGT Stephen L. Vinson
Instrument Operator	SP4 Carl M. Dossier

LIAISON SECTION

Liaison Sergeant	SGT Danny J. Dill
------------------	-------------------

COMMUNICATIONS ELECTRONICS HEADQUARTERS

Platoon Leader	1LT Terrell L. Berkenbile
Communications Chief	SFC Robert O. Mullinax
Senior FADIC Mechanic	SP4 Carl L. Shepherd
Teletype Repairman	SP4 Donald L. Foster
Light Vehicle Driver	SP4 Johnny L. Holcum

WIRE SECTION

Section Chief	SSG Randall J. Ritter
Wire Team Chief	SGT Ronald G. Moss
Senior Field Switchboard Operator	PFC Joe Mayabb
Senior Tactical Wire Specialist	SP4 Dennis W. Narney
Tactical Wire Operator Specialist	SP4 Lee R. York
Wire Team Chief	SGT Larry E. Herdlitchka
Senior Tactical Wire Specialist	SP4 Jerry W. Whitney
Tactical Wire Operator Specialist	SP4 Billy Joe Bell Jr.

RADIO TELETYPEWRITER SECTION

Section Chief	SGT William T. Barton
Radio Teletype Operator	PFC Danny J. Rees

BATTALION SUPPLY SECTION

Unit Supply Technician	CW4 Billy G. Taylor
Battalion Supply Sergeant	SFC Ralph E. Coffey
Supply Specialist	SP4 Gilbert E. Price
Supply Specialist	PVT Nolan D. Long
Light Vehicle Driver	SP4 Richard I. McDaniel
Light Vehicle Driver	SP4 Curtis R. Lee
Light Vehicle Driver	SSG Calvin L. Wallis

BATTALION MAINTENANCE SECTION

Automotive Maintenance Technician	CW2 Donald L. Truskey
-----------------------------------	-----------------------

Battalion Motor Sergeant	MSG Jesse H. Stotts
Material Supply Specialist	SP4 Wilbur C. Hazelton
Welder	SP4 Danny D. Cabe
Wheeled Vehicle Mechanic	SP4 Michael D. Helton
Wheel Vehicle Mechanic	SP4 Edgar R. Riley
Wrecker Operator	PFC Dennis R. York

BATTALION MEDICAL SECTION

Section Sergeant	SSG Charles E. Saxon
Clinical Specialist	SGT Carey D. McMillan
Senior Medical Aidman	SP4 Stephen R. Lynch
Ambulance Driver	SP4 Gerald D. Smith
Battery Aidman	SP4 Kenneth W. Baucom
Battery Aidman	SP4 Thomas R. Calaway
Battery Aidman	SP4 Daniel S. Snare

Battery "A"

Marlow, Oklahoma

BATTERY HEADQUARTERS

Battery Commander	1LT Jimmie D. Sparks
First Sergeant	SFC William A. Woodworth Jr.
Unit Clerk	SP5 William D. Alexander
Light Vehicle Driver	PFC Tony L. Davis
Dining Facility Manager	SFC Louis D. Brower
First Cook	SP6 Woodrow W. Carter Jr.
First Cook	SP5 Bobby J. Miller
Cook	SP5 Max V. VanDyke
Supply Sergeant	SSG Steve H. Brown
Armorer	SSG James H. McNeil III
Motor Sergeant	SSG Herbert W. Martin

Equipment Maintenance Clerk	SP4 Jimmy A. Nichols
Power Generator Mechanic	SP4 Dennis K. Langham
Wheel Vehicle Mechanic	SP4 Stephen R. Condit

COMMUNICATIONS SECTION

Communications Chief	SSG Willard G. Koch
Radio Teletype Team Chief	SGT Steve F. Dowling
Radio Teletype Operator	SP4 Gary L. Langham
Radio Teletype Operator	PFC Donnie D. Lowry

FIRING BATTERY HEADQUARTERS

Executive Officer	2LT Carl G. Bateman Jr.
Chief Firing Battery	SSG George D. Kulbeth
Chief Fire Direction Computer	SSG Jerry A. Green
Assistant Chief Fire Computer	SGT Robert L. Talley
Fire Direction Computer	SSG Lester E. Peterson
Fire Direction Computer	SSG Franklin Tow
Radio Operator	SP4 Bennie D. Whaley

FIRING SECTION NUMBER ONE

Section Chief	SSG John B. Graham
Gunner	SGT George W. Faulkner
Senior Assembly Specialist	SP4 Jerry W. Morgan
Assembly Specialist	SP4 Monty S. Brown
Assembly Specialist	SP4 Larry G. Martin
Field Artillery Recorder	PVT Cecil L. Wright Jr.
Launcher Crewman	PVT Woody I. Hopkins
Launcher Crewman	PVT Lee W. Millhouse
Launcher Crewman	PVT Howard L. Henderson
Assistant Launcher Crewman	PVT Rickey W. Nunn

FIRING SECTION NUMBER TWO

Section Chief	SFC Arthur D. Mullin
Gunner	SSG Theodore L. Lawrence
Senior Assembly Specialist	SSG Gilbert D. Riley
Assembly Specialist	SSG Ronald M. Sparks
Assembly Specialist	SGT Buddy R. Aldridge
Field Artillery Recorder	SGT Joe B. Harper
Launcher Crewman	SGT Harry L. Alsobrook
Launcher Crewman	SP4 Loyd K. Epperson
Launcher Crewman	SP4 Ronald J. Gilpin
Assistant Launcher Crewman	SP4 Elvin T. Hines
Assistant Launcher Crewman	PVT Everett G. Edwards

ASSEMBLY AND TRANSPORT SECTION

Assembly/Transportation Sergeant	SGT Jerry C. Hankins
Senior Assembly Specialist	SGT David J. Robinson
Senior Assembly Specialist	SP4 Gary L. Bray
Assembly Specialist	SP4 Kern C. Heffington
Assembly Specialist	SP4 Michael S. Brown
Boom Operator	SP4 Jerry D. Howell
Boom Operator	SP4 Ricky D. Peck
Launcher Crewman	SP4 Hayden D. Sparks
Launcher Crewman	SP4 Richard L. Radke
Launcher Crewman	SP4 Gary L. Samples
Launcher Crewman	PVT Randy L. Stone

Battery "B"

Walters, Oklahoma

BATTERY HEADQUARTERS

Battery Commander	2LT Mark S. Brown Jr.
-------------------	-----------------------

First Sergeant	MSG Albert J. Vardell
Unit Clerk	SP4 David F. Turnbo
Food Service Sergeant	SSG Robert F. Braly
First Cook	SGT Clinton D. Thurman
Cook	SP4 Curtis M. Parrack
Supply Sergeant	SSG Michael L. Berry
Armorer	SP4 Keith W. Chasteen
Motor Sergeant	SSG Alton L. Burnett
Power Generator Mechanic	PFC Raymond Cole Jr.
Wheel Vehicle Mechanic	SP4 Brian C. Johnson
Wheel Vehicle Mechanic	PFC Clinton L. Whittington
Light Vehicle Driver	PFC Billy F. Berry

COMMUNICATIONS SECTION

Communications Chief	SGT Larry R. Johnson
Radio Tele-Type Team Chief	SGT Robert W. Dilbeck
Radio Tele-Type Operator	PVT Frankie L. Gilbert
Senior Switchboard Operator	SP4 Stephen L. Fletcher
Senior Wire Specialist	PFC Curtis G. Kittrell
Tactical Wire Specialist	PFC Bobby L. Sparks

FIRING BATTERY HEADQUARTERS

Executive Officer	2LT Danny T. Carter
Chief of Firing Battery	SFC Donald J. Logan
Chief Fire Direction Computer	SFC Terry L. Ball
Assistant Chief Fire Computer	SSG Clay F. Dudenhoeffer
Fire Direction Computer	SP5 Arthur L. Ochsner
Fire Direction Computer	SP4 Darrell E. Coker Jr.
Radio Operator	PFC Ricky S. Dean

FIRING SECTION NUMBER ONE

Section Chief	SSG Larry H. Douglas
Gunner	SGT Mickey L. Bentley
Senior Assembly Specialist	SGT Doyle L. Newman
Assembly Specialist	SP4 Clinton A. Auld
Assembly Specialist	SP4 Sammy D. Blair
Launcher Crewman	SP4 Michael L. Hooper
Launcher Crewmen	SP4 Gary J. Thurman
Assistant Launcher Crewman	SP4 Gregory J. Mercado

FIRING SECTION NUMBER TWO

Section Chief	SSG John D. Wahnee
Gunner	SGT Richard R. Briley
Senior Assembly Specialist	SP5 James R. Weaver
Assembly Specialist	SP4 Wendell W. Cromwell
Field Artillery Recorder	SP4 Jack D. Hicks
Launcher Crewman	SP4 Joseph J. McPherson Jr.
Launcher Crewman	SP4 David E. Minton
Launcher Crewman	SP4 Bobby D. Preston
Assistant Launcher Crewman	SP4 Robert F. Odom

ASSEMBLY AND TRANSPORT SECTION

Assembly/Transportation Sergeant	SSG Glend D. Smith
Senior Assembly Specialist	SGT Gary L. Jarvis
Senior Assembly Specialist	SGT Carl E. Leseney Jr.
Assembly Specialist	SP4 Ralph L. Holt
Assembly Specialist	SP4 Barry D. Spurlock
Boom Operator	SP4 Richard N. Phillips
Boom Operator	SP4 Cletis R. Ball
Launcher Crewman	SP4 David L. Thurman
Launcher Crewman	PFC Phil E. Norman
Launcher Crewman	PFC Robert D. Walling Jr.

Battery "C"
Healdton, Oklahoma

BATTERY HEADQUARTERS

Battery Commander	1LT Marvin G. Mosley
First Sergeant	SFC Jerry A. Wilson
Dining Facility Manager	SFC Billy R. Hayes
First Cook	PFC Roland D. Martin
First Cook	SP4 Jimmy D. Gallop
Cook	SP4 Gary W. Gallop
Cook	SP4 Rocky L. Patty
Cooks Helper	PFC Allen K. May
Motor Sergeant	SP5 Bobby W. Wilson
Equipment Maintenance Clerk	SP4 Rickie A. Hudson
Power Generator Mechanic	SP4 David M. Wallace
Prescribed Load List PLL Clerk	SP4 James M. Burris
Wheel Vehicle Mechanic	SP4 Danny D. Morse
Wheel Vehicle Mechanic	SP4 George L. Lowery III
Supply Sergeant	SSG Johnny E. Crabb
Armorer	SP4 Roy O. Tynes
Unit Clerk	SP5 Marshall L. Hunt
Unit Clerk	SP5 Gordon A. Smith
Light Vehicle Driver	PVT Michael R. Manley

COMMUNICATIONS SECTION

Communications Chief	SP5 William G. Blankenship
Radio Teletype Team Chief	SP5 Ronnie A. Hayes
Radio Teletype Operator	SP4 Max N. Burris
Radio Teletype Operator	SP5 Stanley O. Welch
Radio Teletype Operator	SP4 Robert D. Henley Jr.
Radio Teletype Operator	SP4 Jerry W. Carpenter

Senior Switchboard Operator	SP5 John L. Spradlin
Switchboard Operator	SP5 Warren Monday
Senior Wire Specialist	SP4 Johnny C. Fizer Jr.
Tactical Wire Specialist	PVT Clifford K. Hall
Tactical Wire Specialist	PVT Wesley R. Alexander

FIRING BATTERY HEADQUARTERS

Executive Officer	Vacant
Chief of Firing Battery	SFC Billy Z. Fore
Chief Fire Direction Computer	SFC Charles R. Devenport
Assistant Chief Fire Computer	SP5 Thomas J. Phelps
Fire Direction Computer	SP5 Larry R. Pickelsimer
Fire Direction Computer	SP5 Larry D. Milson
Fire Direction Computer	SP5 Clyde M. Folsom
Radio Operator	PVT Kenneth G. Tyler
Radio Operator	PVT Frank A. Goldenstein

FIRING SECTION NUMBER ONE

Section Chief	SSG William C. Mitchell III
Gunner	SP5 Roger D. Carney
Gunner	SP5 Johnny L. Hartman
Senior Assembly Specialist	SP5 John J. Kloiber Jr.
Senior Assembly Specialist	SP5 Loran R. Hacker
Assembly Specialist	SP4 Jimmy D. Carnell
Assembly Specialist	SP4 Larry D. Gilcrease
Field Artillery Recorder	PVT Robert E. Lee
Launcher Crewman	SP4 Jerry L. Brown
Launcher Crewman	SP4 Donald K. Banes
Launcher Crewman	PVT Lovell G. Perry
Launcher Crewman	PVT Thomas C. Parker
Assistant Launcher Crewman	SP5 Thomas C. Harris

Assistant Launcher Crewman	PVT Jerry L. Landram
Assistant Launcher Crewman	PVT Johnny B. Webb
Assistant Launcher Crewman	PVT John R. Brecheen

FIRING SECTION NUMBER TWO

Section Leader	Vacant
Section Chief	SSG Vernon K. Isbell
Gunner	SP5 Wayne D. Reid
Gunner	SP5 Lindsay D. Thomas
Senior Assembly Specialist	SP4 Carl W. Adams
Assembly Specialist	SP4 Craig Roberts
Assembly Specialist	SP4 Gen D. Brown
Field Artillery Recorder	PFC Robert A. Brecheen
Launcher Crewman	SP4 Michael R. Belvin
Launcher Crewman	SP4 George E. Hodge
Launcher Crewman	PVT James M. Blackerby
Assistant Launcher Crewman	PFC Ricky J. Smith
Assistant Launcher Crewman	PVT Fred D. Franklin
Assistant Launcher Crewman	PVT Michael R. Gregg
Assistant Launcher Crewman	PVT Johnny D. Doughty

ASSEMBLY AND TRANSPORT SECTION

Ammunition Officer	CW2 Robert D. Treadwell
Assembly/Transportation Sergeant	SSG Gerald L. Timmons
Senior Assembly Specialist	SP5 Allen C. White
Senior Assembly Specialist	SP5 Larry K. Longest
Assembly Specialist	PFC Leonard T. Jones
Assembly Specialist	PVT Kenneth D. Pickelsimer
Boom Operator	PVT Michael G. Williams
Boom Operator	SP4 James D. Cottrell
Launcher Crewman	SP4 Ola W. Williams

Launcher Crewman
Launcher Crewman
Launcher Crewman
Launcher Crewman
Launcher Crewman
Launcher Crewman
Launcher Crewman

SP4 Kenneth R. Varner
SP4 Arthur A. Wilson
SP4 Raymond A. Brown
PFC Ricky L. Pender
PFC Vernie L. Thompson
SP5 Jack E. Brown
PVT Andy J. Wilson

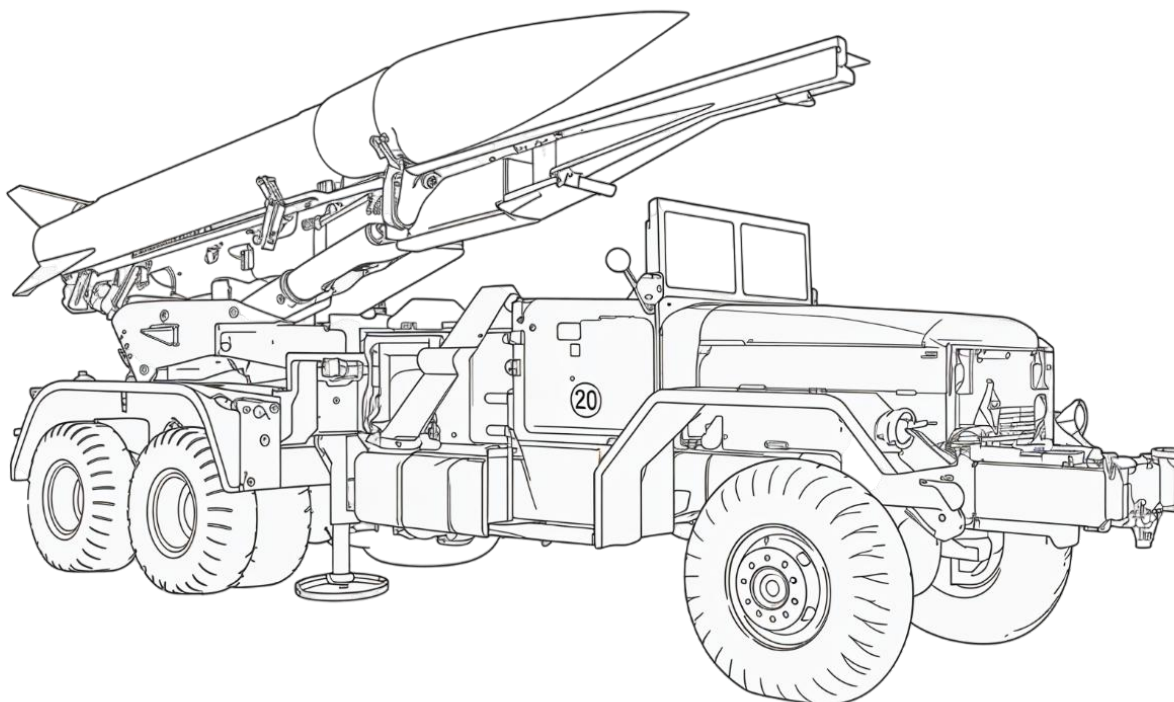

ROSTER OF MEMBERSHIP 1 January 1976

**2nd Battalion (Honest John)
158th Field Artillery
Headquarters and Headquarters Battery
Oklahoma City, Oklahoma**

BATTALION HEADQUARTERS

Battalion Commander	LTC Robert E. Clark
Executive Officer	MAJ Calvin E. Koonce
S-3	CPT Henry D. Thornton
Battalion Surgeon	CPT Robert E. Edde
C-E Staff Officer	1LT John J. Hawk
Liaison Officer	CPT Christopher P. Bills
S-1	CPT Kenneth F. Perry
S-2	1LT Charles P. Jones
S-4	CPT Preston F. Willoughby
Command Sergeant Major	SGM Rudy N. Hightower

BATTERY HEADQUARTERS

Battery Commander	CPT Gary D. Maynard
First Sergeant	1SG Bobby G. Pierce
Dining Facility Manager	SFC Louis Brower
First Cook	SP5 Gerald W. Robinson
First Cook	SP4 Kenneth R. Pickard
First Cook	SP4 Ronald Fletcher
Cook	PFC Tommy L. Mullins
Wheel Vehicle Mechanic	SSG William F. Seiter
Equipment Maintenance Clerk	SP4 Roy L. Waldroop
Power Generator Mechanic	SP5 J.B. Cooper
Wheel Vehicle Mechanic	SP4 Anthony E. West
Wheel Vehicle Mechanic	SP4 Matthew A. Davis
Power Generator Equipment Helper	SP4 Gerald W. Williams
Supply Sergeant	SGT Edgar Y. Ragle
Armorer	SP4 Warner P. Bentley
Unit Clerk	SP5 Edgar D. Quaid
Light Vehicle Driver	SP4 Charles A. Gasaway

HEADQUARTERS SUPPORT SECTION

Personnel Staff NCO	SFC Floyd T. Todd
Legal Clerk	SP5 Alfred N. Blakely
Clerk Typist	SP4 Kenneth I. Stone

UNIT PERSONNEL SECTION

Unit Personnel Technician	CW2 Loyd Todd Jr.
Personnel Management Specialist	SP5 Gary P. Bates
Personal Records Specialist	PVT Larry D. Tempson
Personnel Actions Specialist	PVT Jackson J. Ross
Finance Specialist	SP5 David J. Jones
Finance Specialist	SP4 Thomas W. Duncan

OPERATIONS AND FIRE DIRECTION CENTER SECTION

Fire Direction Officer	CPT Vincente J. Scalice
Operations Sergeant	SFC John Snow
Intelligence Sergeant	SFC John C. Gibson
Chief Fire Direction Computer	SFC Jean R. Herring
Assistant Chief Fire Computer	SGT Donald Watson
Fire Direction Computer	SP5 Walter M. Stoyoski
Fire Direction Computer	SP5 Randolph M. Baker
Fire Direction Computer	SP5 Gary L. Maxon
Clerk Typist	SSG Richard D. Mutz
Clerk Typist	SP4 Edward A. Beson

SURVEY SECTION

Chief Surveyor	SFC Elmer C. Kelley
Survey Computer	SGT Randolph A. Knight
Instrument Operator	SP4 Uley R. Jones Jr.
Survey Recorder	SP5 Johnnie L. Turnage
Survey Computer	SGT Stephen L. Vinson

Instrument Operator	SP4 Carl M. Dossier
Survey Recorder	SP4 William G. Schmitz
Rodman-Tapeman	SP4 R. J. Akins
Chief of Survey Party	SP5 Elbert B. Rouse
Survey Computer	SP4 Don L. Litle
Survey Computer	PVT Jeffery L. Hornbeck
Instrument Operator	SP4 Gary L. Sullivan

LIAISON SECTION

Liaison Sergeant	SGT Danny J. Dill
------------------	-------------------

COMMUNICATIONS ELECTRONICS HEADQUARTERS

Platoon Leader	1LT Terrell L. Berkenbile
Communications Chief	SFC Robert O. Mullinax
Senior FADIC Mechanic	SP4 Carl Carl L. Shepherd
Teletype Equipment Repairman	SP4 Donald L. Foster
Light Vehicle Driver	SP4 Johnny L. Holcum

WIRE SECTION

Section Chief	SSG Randall J. Ritter
Wire Team Chief	SGT Ronald G. Moss
Senior Field Switchboard Operator	PFC Joe Mayabb
Senior Tactical Wire Specialist	SP4 Dennis W. Narney
Tactical Wire Operator Specialist	SP4 Lee R. York
Wire Team Chief	SGT Larry E. Herdlitchka
Senior Tactical Wire Specialist	SP4 Jerry W. Whitney
Tactical Wire Operator Specialist	SP4 Billy Joe Bell Jr.

RADIO TELETYPEWRITER SECTION

Section Chief	SGT William T. Barton
Radio Teletype Operator	PFC Danny J. Rees

BATTALION SUPPLY SECTION

Unit Supply Technician	CW4 Billy G. Taylor
Battalion Supply Sergeant	SFC Ralph E. Coffey
Supply Specialist	PVT Nolan D. Long
Supply Specialist	SP4 Gilbert E. Price
Light Vehicle Driver	SP4 Richard I. McDaniel
Light Vehicle Driver	SP4 Curtis R. Lee
Light Vehicle Driver	SSG Calvin L. Wallis

BATTALION MAINTENANCE SECTION

Automotive Maintenance Technician	CW2 Donald L. Truskey
Battalion Motor Sergeant	MSG Jesse H. Stotts
Material Supply Specialist	SP4 Wilbur C. Hazelton
Welder	SP4 Danny D. Cabe
Wheeled Vehicle Mechanic	SP4 Michael D. Helton
Wheel Vehicle Mechanic	SP4 Edgar R. Riley
Wrecker Operator	PFC Dennis R. York

BATTALION MEDICAL SECTION

Section Sergeant	SSG Charles E. Saxon
Clinical Specialist	SGT Carey D. McMillen
Senior Medical Aidman	SP4 Stephen R. Lynch
Ambulance Driver	SP4 Gerald D. Smith
Battery Aidman	SP4 Kenneth W. Baucom
Battery Aidman	SP4 Thomas R. Calaway
Battery Aidman	SP4 Daniel S. Snare

Battery "A"

Marlow, Oklahoma

BATTERY HEADQUARTERS

Battery Commander	1LT Jimmy D. Sparks
First Sergeant	SFC William A. Woodworth Jr.
Unit Clerk	SP5 William D. Alexander
Light Vehicle Driver	PVT Stephen R. Ensminger
Dining Facility Manager	SP5 Bobby J. Miller
First Cook	SP5 Max V. VanDyke
First Cook	SP4 Gary W. Gallop
Cook	PVT Randy L. Stone
Supply Sergeant	SSG Steven H. Brown
Armorer	SSG James H. McNeil III
Motor Sergeant	SP4 Jimmy A. Nichols
Equipment Maintenance Clerk	SP4 Dennis K. Langham
Power Generator Mechanic	SP4 Stephen R. Condit
Wheel Vehicle Mechanic	PVT Lloyd A. Sanders
Wheel Vehicle Mechanic	PVT Harold P. Melton

COMMUNICATIONS SECTION

Communications Chief	SGT Steven F. Dowling
Radio Teletype Team Chief	SGT Gary L. Langham
Radio Teletype Operator	SP4 Donnie D. Lowry
Radio Teletype Operator	SP4 Freddy D. Haragan

FIRING BATTERY HEADQUARTERS

Executive Officer	1LT Carl G. Bateman Jr.
Chief Firing Battery	SSG George D. Kulbeth
Chief Fire Direction Computer	SFC Jerry A. Green
Assistant Chief Fire Computer	SSG Robert L. Talley
Fire Direction Computer	SSG Lester E. Petersen
Fire Direction Computer	SSG Franklin Tow
Radio Operator	SP5 Bennie D. Whaley

FIRING SECTION NUMBER ONE

Section Chief	2LT Bruce M. Wood
Section Chief	SGT George W. Faulkner
Gunner	SP4 Johnie E. Farley
Senior Assembly Specialist	SP4 Monty S. Brown
Assembly Specialist	SP4 Hayden D. Sparks
Assembly Specialist	SP4 Loyd K. Epperson
Field Artillery Recorder	PFC Cecil L. Wright Jr.
Launcher Crewman	PFC Lee W. Millhouse
Launcher Crewman	PFC Howard L. Henderson
Launcher Crewman	PVT Billy J. Calhoun

ASSEMBLY AND TRANSPORT SECTION

Ammunition Officer	2LT Richard L. Sacket
Assembly/Transportation Sergeant	SGT Jerry C. Hankins
Senior Assembly Specialist	SGT David J. Robinson
Senior Assembly Specialist	SGT Buddy R. Aldridge
Assembly Specialist	SP4 Kern L. Heffington
Assembly Specialist	SP4 Michael S. Brown
Boom Operator	SP4 Jerry D. Howell
Boom Operator	SP4 Ricky D. Peck
Launcher Crewman	SP4 Tony L. Davis
Launcher Crewman	PFC Rickey W. Nunn
Launcher Crewman	PFC Woody I. Hopkins
Launcher Crewman	PFC James M. Lee

Battery "B"

Walters, Oklahoma

BATTERY HEADQUARTERS

Battery Commander	CPT John H. Scaggs
-------------------	--------------------

First Sergeant	MSG Albert J. Vardell
Unit Clerk	SP4 David F. Turnbo
Food Service Sergeant	SGT Clinton D. Thurman
First Cook	SP4 Curtis M. Parrack
Cook	SP4 Gary J. Thurman
Supply Sergeant	SSG Michael L. Berry
Armorer	SP5 Keith W. Chasteen
Motor Sergeant	SP4 Robert A. Redelk
Power Generator Mechanic	PVT Raymond Cole Jr.
Assistant Wheel Vehicle Mechanic	SP4 Brian C. Johnson

COMMUNICATIONS SECTION

Communications Chief	SGT Carl E. Leseney Jr.
Radio Tele-Type Team Chief	SGT Robert W. Dillbeck
Radio Tele-Type Operator	PVT Frankie L. Gilbert
Tactical Wire Operator Specialist	PVT Bobby L. Sparks

FIRING BATTERY HEADQUARTERS

Executive Officer	1LT Danny T. Carter
Chief of Firing Battery	SFC Donald J. Logan
Chief Fire Direction Computer	SFC Clay F. Dudenhoeffer
Fire Direction Computer	SSG Arthur L. Cohsner
Fire Direction Computer	SGT Darrell E. Coker Jr.
Radio Operator	SP4 Ricky S. Dean

FIRING SECTION NUMBER ONE

Section Leader	2LT Doyle L. Newman
Section Chief	SSG Mickey L. Bentley
Senior Assembly Specialist	SP4 Clinton A. Auld
Assembly Specialist	SP4 Sammy D. Blair
Assembly Specialist	SP4 Layne D. Sterett

Assistant Launcher Crewman	PFC Billy F. Berry
Assistant Launcher Crewman	SP4 Gregory J. Mercado

FIRING SECTION NUMBER TWO

Section Leader	2LT Michael D. White
Section Chief	SSG John D. Wahnee
Gunner	SGT Michael D. Hooper
Senior Assembly Specialist	SP5 Larry W. Shelton
Assembly Specialist	SP5 James R. Weaver
Field Artillery Recorder	SGT David E. Minton
Launcher Crewman	PVT Larry W. Tyson
Launcher Crewman	SP4 Eddie S. Overstreet
Launcher Crewman	PVT Charles A. Gibson II
Assistant Launcher Crewman	SP4 Bobby D. Preston
Assistant Launcher Crewman	SP4 Joseph J. McPherson Jr.

ASSEMBLY AND TRANSPORT SECTION

Ammunition Officer	2LT William F. White
Assembly/Transportation Sergeant	SSG Gary L. Jarvis
Senior Assembly Specialist	SP5 Barry D. Spurlock
Senior Assembly Specialist	SP4 Ralph L. Holt
Assembly Specialist	SP4 Cletis R. Ball
Boom Operator	SP4 Richard N. Phillips
Launcher Crewman	PVT Charles J. Coonfield
Launcher Crewman	PVT Bobby Sides
Launcher Crewman	SP4 David L. Thurman

Battery "C"
Heldton, Oklahoma

BATTERY HEADQUARTERS

Battery Commander	CPT Donald R. Hathorn
First Sergeant	SFC Jerry A. Wilson
Dining Facility Manager	SFC Billy R. Hayes
First Cook	SP4 Roland D. Martin
First Cook	SP4 Jimmy D. Gallop
Cook	SP4 Virgil M. Gallop
Cook	PFC Rocky L. Patty
Cooks Helper	PFC Larry D. Gilcrease
Cooks Helper	PFC Allen K. May
Motor Sergeant	SGT Bobby W. Wilson
Equipment Maintenance Clerk	SP4 Rickie A. Hudson
Power Generator Mechanic	SP4 David M. Wallace
Prescribed Load List PLL Clerk	SP4 Scott V. Horn
Wheel Vehicle Mechanic	SP4 Danny D. Morse
Wheel Vehicle Mechanic	SP5 Billy H. McLaughlin
Supply Sergeant	SSG Johnny E. Crabb
Armorer	PFC Lyndon B. Teafatiller
Unit Clerk	SP6 Marshall L. Hunt
Light Vehicle Driver	PFC Michael R. Manley

COMMUNICATIONS SECTION

Communications Chief	SSG Billy D. Blankenship
Radio Teletype Team Chief	SP5 Max N. Burris
Radio Teletype Operator	SP4 Robert D. Henley Jr.
Radio Teletype Operator	SP4 Jerry W. Carpenter
Radio Teletype Operator	SP4 Billy S. Hornbeck
Senior Field Switchboard Operator	PFC Vernie L. Thompson
Senior Tactical Wire Specialist	SP5 John L. Spradlin
Tactical Wire Operator Specialist	PFC Wesley R. Alexander
Tactical Wire Operator Specialist	PFC Clifford K. Hall

FIRING BATTERY HEADQUARTERS

Executive Officer	1LT Marvin G. Mosley
Chief of Firing Battery	SFC Billy Z. Fore
Chief of Firing Battery	SFC Billy S. Warrington
Chief Fire Direction Computer	SFC Charles R. Davenport
Chief Fire Direction Computer	SFC John W. Walker
Assistant Chief Fire Computer	SP5 Jerry N. Underwood
Assistant Chief Fire Computer	SP5 Ronnie A. Hayes
Fire Direction Computer	SP5 Johnnie C. Fizer Jr.
Fire Direction Computer	SP4 Glen D. Brown
Radio Operator	PFC Fred D. Franklin
Radio Operator	PFC Frank A. Goldenstein Jr.

FIRING SECTION NUMBER ONE

Section Leader	CW2 Robert D. Treadwell
Section Chief	SSG William C. Mitchell III
Gunner	SP5 James M. Burris
Senior Assembly Specialist	SP5 Carl W. Adams
Assembly Specialist	SP5 Leonard T. Jones
Assembly Specialist	SP4 Kenneth D. Pickelsimer
Field Artillery Recorder	PFC Robert E. Lee
Launcher Crewman	SP4 Ola W. Williams
Launcher Crewman	SP4 Jerry L. Brown
Launcher Crewman	PFC Ricky J. Smith
Assistant Launcher Crewman	PVT Jerry L. Landram
Assistant Launcher Crewman	PVT John R. Brecheen
Assistant Launcher Crewman	PVT Johnny D. Doughty

FIRING SECTION NUMBER TWO

Section Leader	2LT James W. Kimberlin
Section Chief	SSG Vernon K. Isbell

Gunner	SGT Wayne D. Reid
Senior Assembly Specialist	SP5 Johnny L. Hartman
Assembly Specialist	SP4 John W. Kloiber Jr.
Field Artillery Recorder	SP4 Craig Roberts
Launcher Crewman	SP4 Larry D. Mercer
Launcher Crewman	PFC Raymond D. Brown
Launcher Crewman	PFC Andy J. Wilson
Assistant Launcher Crewman	PFC Kenneth G. Tyler
Assistant Launcher Crewman	PFC Larry E. Denney
Assistant Launcher Crewman	PVT Marlan V. Banta Jr.

ASSEMBLY AND TRANSPORT SECTION

Ammunition Officer	1LT James L. Welch
Assembly/Transportation Sergeant	SSG Gerald L. Timmons
Assembly/Transportation Sergeant	SSG Allen C. White
Senior Assembly Specialist	SP5 Larry D. Milson
Assembly Specialist	SP4 James D. Cottrell
Assembly Specialist	SP4 Arthur A. Wilson
Boom Operator	SP5 Larry R. Pickelsimer
Boom Operator	SGT Ronald W. McMillen
Launcher Crewman	SP4 Kenneth R. Varner
Launcher Crewman	PFC Michael G. Williams
Launcher Crewman	PFC Thomas C. Parker
Launcher Crewman	PVT Johnny G. Webb
Launcher Crewman	SP5 Roger D. Carney
Launcher Crewman	SP4 Robert A. Brecheen
Launcher Crewman	SP4 Jimmy D. Denney
Launcher Crewman	PVT Alan L. Buck

2nd Battalion 158th Field Artillery

Honest John Rocket

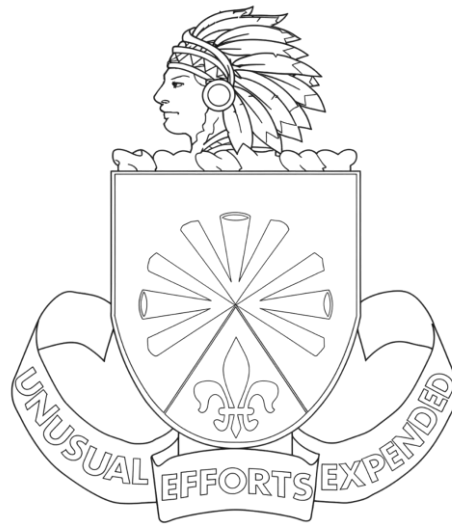

BATTERY C
ANNUAL TRAINING --- 1975

SECOND BATTALION (HJ)

158th FIELD ARTILLERY
FORT CHAFFEE, ARKANSAS

FIRST ROW:
MAY, A. K., SP4
GILCREASE, L. D., SP4
MARTIN, R. D., SP4
GALLOP, G. W., SP4
GALLOP, J. D., SP4
EBELL, V. K., SSG
DICKERSON, R. D., SSG
MITCHELL, W. C., SSG
FORE, B. Z., SFC
WILSON, J. A., SFC
TREADWELL, R. D., CW2

HATHORN, D. R., CPT
MUSLEY, M. G., 1LT
WELCH, J. L., 1LT
DEVENPORT, C. R., SFC
WARRINGTON, B. E., SSG
CRABB, J. E., SSG
TIMMONS, G. L., SSG
ALEXANDER, W. R., E2
MANLEY, M. R., E2
PATTY, R. L., SP4
THOMPSON, V., E4

SECOND ROW:
HORN, S. V., SP4
VARNER, K. R., SP4
BROWN, J. L., SP4
SMITH, R. J., PFC
WHITE, A. C., SP5
BROWN, G. D., SP4
COTTRELL, J. D., SP4
PENDER, R. L., SP4
JONES, L. T., SP4
PICKELSIMER, E. D., PFC
CARNELL, J. D., SP4

WILSON, B. W., SGT
PICKELSIMER, L. R., SP5
REID, W. D., SGT
DENNEY, J. D., SGT E5
HUDSON, R. A., SP4
MORSE, D. D., E4
BURRIS, J. M., SP4
PHELPS, T. J., E5
FOLSOM, C. M., E5
WELCH, S. O., SGT E5
FIZER, J. C., SP4
ADAMS, C. W., SP4

THIRD ROW:
HUNT, M. L., SP5
BLANKENSHIP, B. D., SP5
KLODNER, J., SP5
THOMAS, L. D., SP5
WALLACE, D. M., SP4
DENNEY, L. E., SGT E5
WILSON, A. J., E2
LONGEST, L. K., SP5
PARKER, C., E2
WILLIAMS, G. W., SP4
BROWN, R. A., PFC

ROBERTS, C., SP4
HARTMAN, J. L., SP5
SMITH, G. A., SP5
LOWERY, G. L., SP4
BRECHEEN, R. B., PFC
HACKER, L. R., SP5
RODIE, G. E., SP4
HORNBECK, B. S., SP4
SPRADLIN, J. L., SP5
BENLEY, R. D., SP4
CARPENTER, J., PFC
BURRIS, M. N., SP4

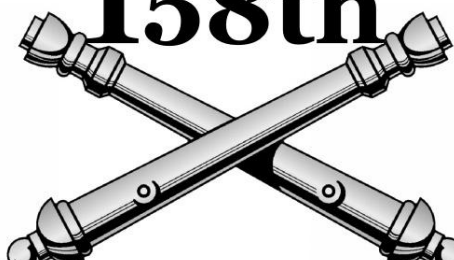
158th

Field Artillery

3955 Cannoneer Field Road

Fort Sill, Oklahoma 73503



Est. 1975 - 1977