

Experience The Power  
Of Global Support



**Motors and Fluid-moving Products  
From Gaudenttech for Many Applications**



Manufacturing plants in China and Vietnam

# CONTENTS

## DC series hydraulic power unit

- 09 Mini Pallet Truck Hydraulic Power Unit
- 10 Pallet Truck Hydraulic Power Unit
- 11 Stacker Fork Lift Hydraulic Power unit
- 12 Portable stacker power unit
- 13 Hydraulic power unit of full electric stacker
- 14 Power unit of forward moving stacker
- 15 Dump trailer power unit
- 16 Hydraulic tailboard power unit
- 17 DC motor pump station
- 18 Aerial vehicle electric pump
- 19 Power unit of electric jib forklift
- 20 Mobile lifting platform power unit
- 21 DC bidirectional pump power unit
- 22 DC single acting power unit
- 23 DC double acting power unit
- 24 DC micro power unit

## Other

- 45 Power unit accessories
- 48 Hydraulic system and oil cylinder
- 05 Silent power unit of hydraulic cargo elevator
- 07 Oil immersed double acting power unit



## AC series hydraulic power unit

- 25 Boarding axle power unit A
- 26 Boarding axle power unit B
- 27 Lifting platform power unit A
- 28 Lifting platform power unit B
- 29 Large shear lifting power unit
- 30 Telescopic belt power unit
- 31 Hydraulic clamping power unit of machine tool
- 32 Welding machine power unit
- 33 Pipe cutting power unit
- 34 Power unit of storage flushing door
- 35 AC double acting power unit

## Oil immersed series power unit

- 36 Integrated lifting column power unit
- 37 Integrated multistage cylinder lifting column power unit
- 38 Split lifting column power unit
- 39 Split multistage cylinder lifting column power unit
- 40 Anti terrorism roadblock power unit
- 41 Oil immersed bidirectional pump power unit
- 42 Oil immersed double acting power unit
- 43 Silent power unit of hydraulic cargo elevator
- 44 Parking garage silent power unit

# PRODUCTION WORKSHOP

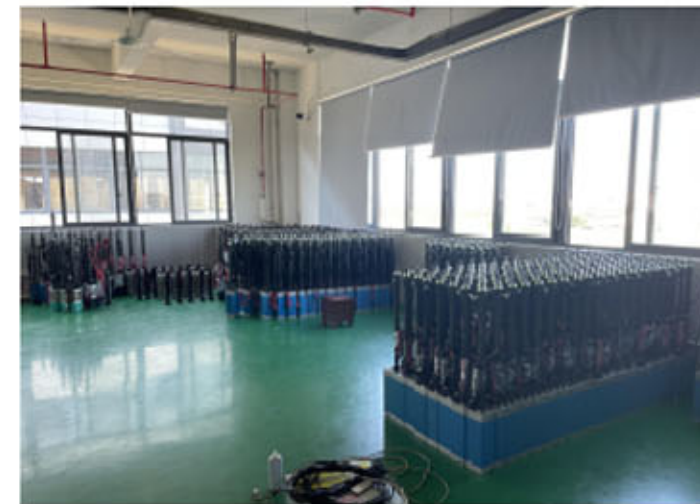

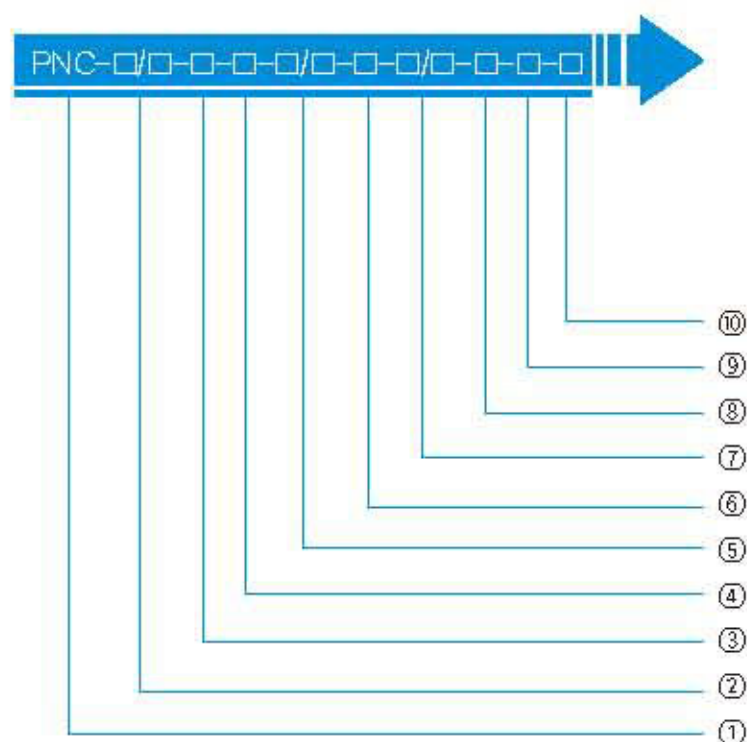

① 产品名称：液动力单元 Product name:hydraulic power units

② 电机功率 Motor power ( KW )

直流电机 DC motor: 0.3 0.5 0.8 1.2 1.6 2.2 3 4  
交流电机 AC motor: 0.3 0.55 0.75 1.1 1.5 2.2 3 4  
单相 S : single phase      三相 3 : three single  
默认三相电机 Default three-phase motor

③ 电机极数 Number of motor poles

二极电机 Two pole motor : 2P  
四极电机 Four pole motor : 4P  
六极电机 Six pole motor : 6P  
仅限交流电机选型使用/Only for AC motor selection

④ 电机电压 Motor voltage ( V )

直流电机 DC motor: D12 D24 D36 D48  
交流电机 AC motor: A110 A220 A380 A440  
其他规格详询工厂代表/For other specifications, please refer to the factory business

⑤ 齿轮泵排量 Pump displacement ( cc/rev )

1组泵 / 1 series pump : 0.63 0.8 1.2 1.6 2.1 2.7 3.2 3.7 4.2 5.0 6.0 7.0 8.0 9.8  
0.5组泵 / 0.5 series pump : 0.19 0.26 0.38 0.5 0.65 0.75 0.88 1.0 1.25 1.5 1.75 2.0  
型号默认单向泵，双向泵表示方法  
The model defaults to one-way pump , two-way pump : 0.5T/0.26

⑥ 溢流阀设定压力 Relief valve set pressure ( MPA )

根据客户需要设定，例如 Set according to customer needs, such as :16

⑦ 油箱容积与外型 Tank volume and appearance ( L )

容积 Volume : 1 1.5 2.5 3 4 5 6 8 10 15 20 30  
立式安装 Vertical installation : L      卧式安装 Horizontal installation : W

⑧ 液压原理图 详细信息见下页液动力单元原理编号

Hydraulic schematic diagram See the hydraulic power unit principle number on the next page for details

⑨ 内置压力补偿阀流量 Built in pressure compensation valve flow (L/MIN)

固定流量压力补偿阀 Fixed flow pressure compensator valve : 1 2 3 4 5 6 7 8 9 10 12  
可调流量压力补偿阀 Adjustable pressrue compensation valve M10 M16

⑩ 特殊说明 Special instructions

**原理图组合**  
SCHEMATIC COMBINATION

以下为我司常用液动力单元原理图组合，我司也可以按照客户要求定制特殊的油路。具体请联系我司业务员。

The following is the schematic diagram combination of our common hydraulic power units. Our company can also customize special oil circuits according to customer requirements. Please contact our salesman for details.

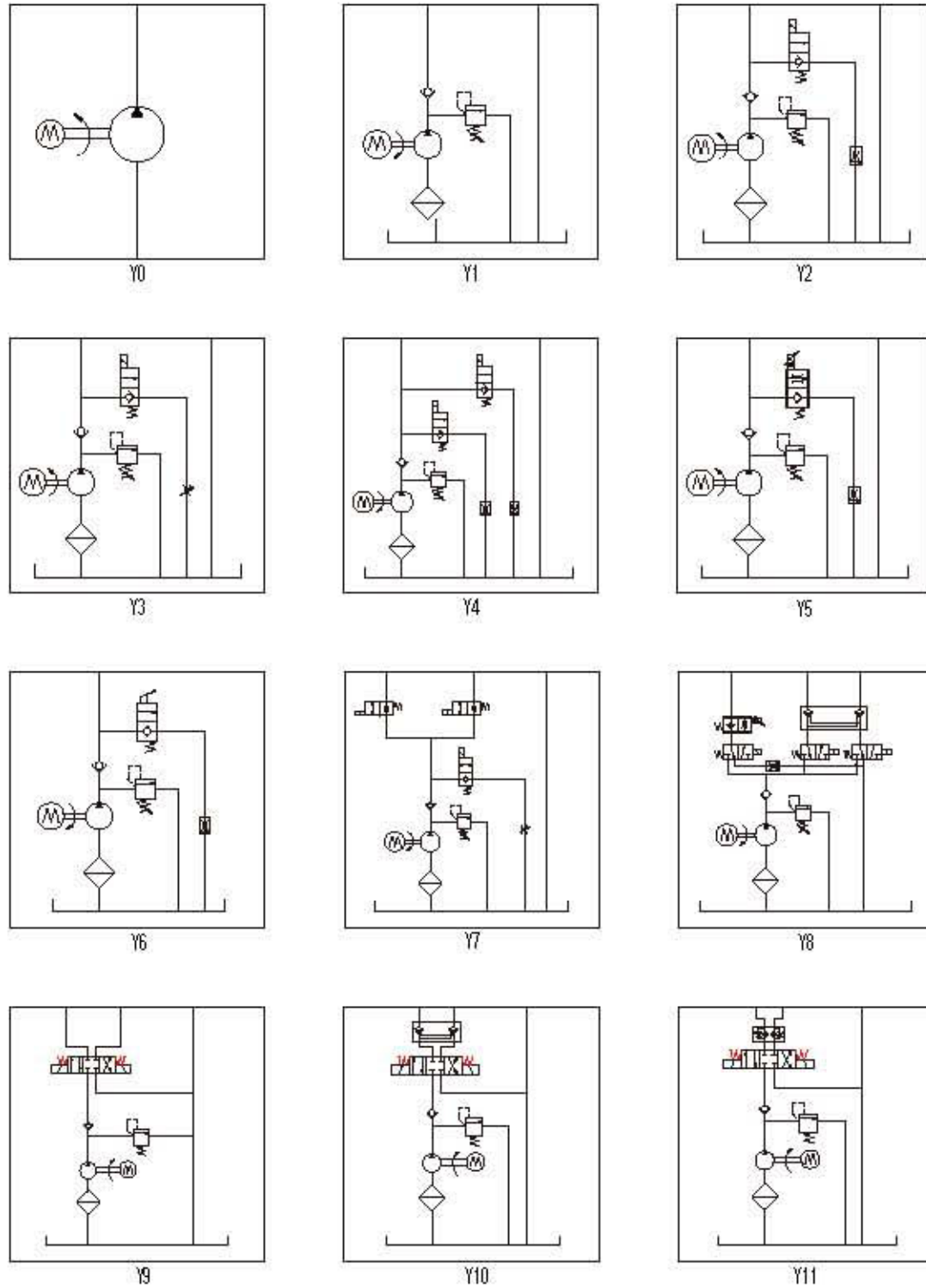

**原理图组合**  
SCHEMATIC COMBINATION

以下为我司常用液动力单元原理图组合，我司也可以按照客户要求定制特殊的油路。具体请联系我司业务员。

The following is the schematic diagram combination of our common hydraulic power units. Our company can also customize special oil circuits according to customer requirements. Please contact our salesman for details.

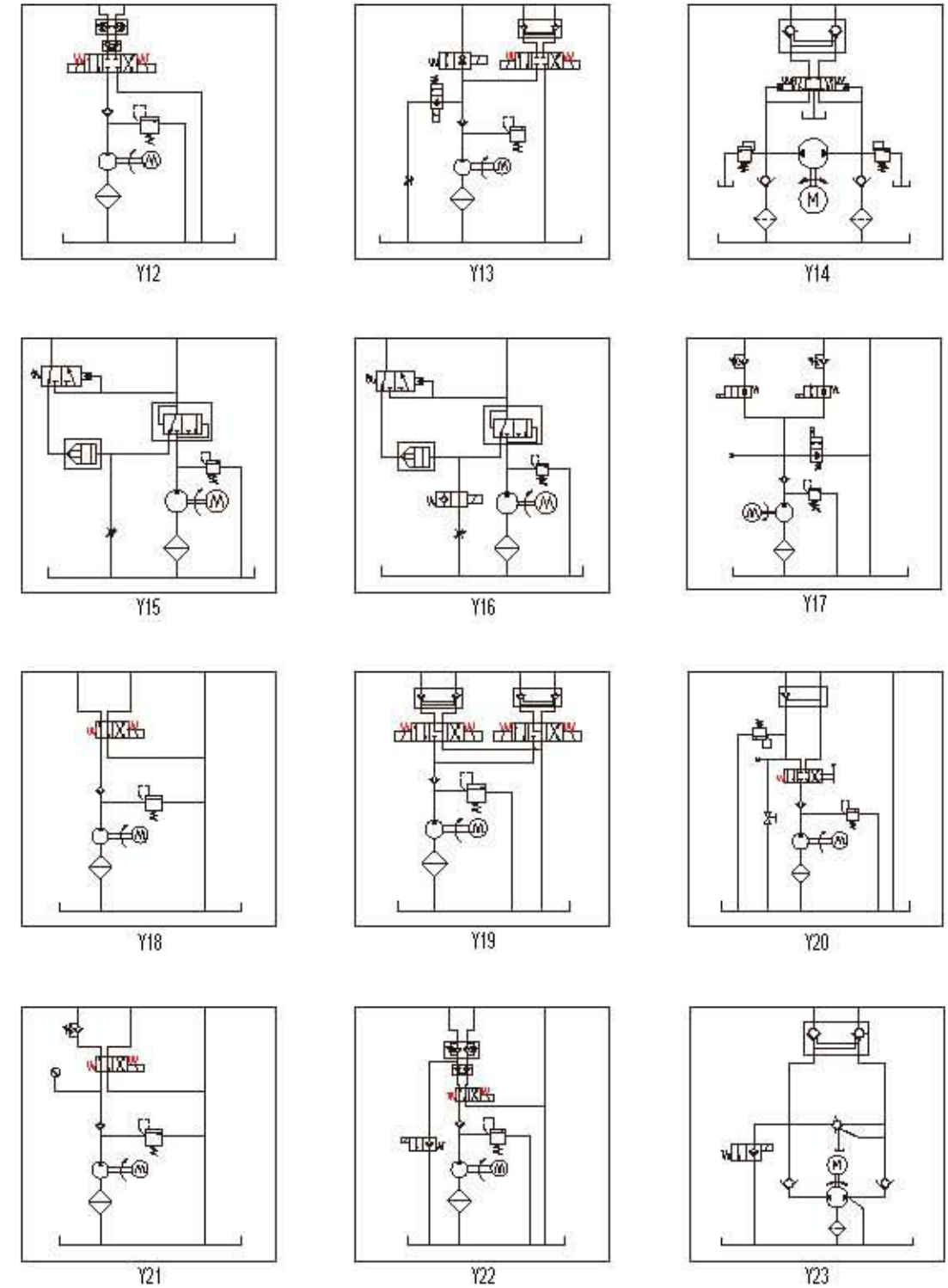

## 电动小金刚液压力单元

MINI PALLET TRUCK HYDRAULIC POWER UNIT

此液压力单元专为全电动托盘车所设计。由高压齿轮泵、永磁直流电机、中心阀块、插装阀、油箱集成为一体。启动电机，实现上升，打开电磁阀，实现下降。内置压力补偿节流阀控制下降速度。具有0.3-0.8KW可选电机，电压12-48V可选，有铁制和塑料油箱可供选择。

This hydraulic power unit is specially designed for all electric pallet truck. It consists of high voltage gear pump, permanent magnet DC motor and central valve block. The cartridge valve and oil tank are integrated. Start the motor to rise, open the solenoid valve to fall. The built-in pressure compensation throttle valve controls the descent speed. With 0.3-0.8kw optional motor, 12-48v optional voltage, iron and plastic oil tank for choice.



### 原理图/SCHEMATIC DIAGRAM

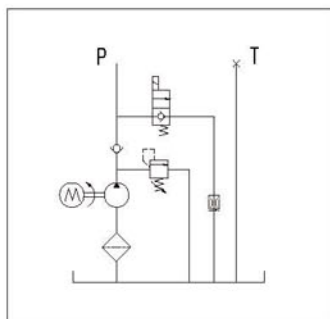

Y2

### 注意事项/SPECIAL NOTES

- 此动力单元为S3工作制，不可连续运转，10秒开，90秒停。
- 安装前必须保证油缸、油管、接头等液压元件无杂质黏附。
- 液压油粘度应为15-68ST，夏季推荐46号抗磨液压油，冬季推荐32号低温液压油。
- 首次启动运行系统后，应立即检查油箱中的油量是否充足，一般为油箱2/3部位。
- 系统使用第一个100小时后，应更换液压油，以后每3000小时更换一次液压油。
- The power unit is S3 working system and can not operate continuously. It starts in 10 seconds and stops in 90 seconds.
- Before installation, ensure that hydraulic components such as oil cylinder, oil pipe and joint are free of impurities.
- The viscosity of hydraulic oil shall be 15-68st. No. 46 anti-wear hydraulic oil is recommended in summer and No. 32 low temperature hydraulic oil is recommended in winter.
- After starting the operating system for the first time, check whether the oil in the oil tank is sufficient, generally 2 / 3 of the oil tank.
- After the system is used for the first 100 hours, the hydraulic oil she replaced, and then the hydraulic oil shall be replaced every 3000 hours.

### 产品配置/SPECIFICATIONS

型号 Model	电压 Volt	功率 Power	转速 Speed	油泵排量 Displacemet	工作压力 Pressure	油箱 Tank	电磁阀电压 Solenoid Vavle Volt
PNC-0.5-D12-0.5/0.38-16-1/W-Y2	12VDC	0.5KW	2800RPM	0.38CC/REV	16MPA	1L	12VDC
PNC-0.8-D12-0.5/0.65-16-1/W-Y2		0.8KW	3100RPM	0.65CC/REV			
PNC-0.5-D24-0.5/0.38-16-1/W-Y2	24VDC	0.5KW	2800RPM	0.38CC/REV			24VDC
PNC-0.8-D24-0.5/0.65-16-1/W-Y2		0.8KW	3400RPM	0.65CC/REV			
PNC-0.8-D48-0.5/0.65-16-1/W-Y2	48VDC	0.8KW	3100RPM		0.65CC/REV	48VDC	

说明：如需不同流量得泵、压力、电机功率等系统参数，请联系我司业务员。

Note: if you need system parameters such as pump, pressure and motor power with different flow, please contact our salesman.

## 电动搬运车液压力单元

PALLET TRUCK HYDRAULIC POWER UNIT

此液压力单元专为全电动搬运车所设计。由高压齿轮泵、永磁直流电机、中心阀块、插装阀、油箱集成为一体。启动电机，实现上升，打开电磁阀，实现下降。内置压力补偿节流阀控制下降速度。具有0.8-1.2KW可选电机，电压24-48V可选，有铁制和塑料油箱可供选择。

This hydraulic power unit is specially designed for all electric carrier. It is composed of high pressure gear pump, DC motor, central valve block, cartridge valve and oil tank. Start the motor to rise, open the solenoid valve to fall. The built-in pressure compensation throttle valve controls the descent speed. With 0.8-1.2kw optional motor, 24-48v optional voltage, iron and plastic oil tank for choice.



### 原理图/SCHEMATIC DIAGRAM

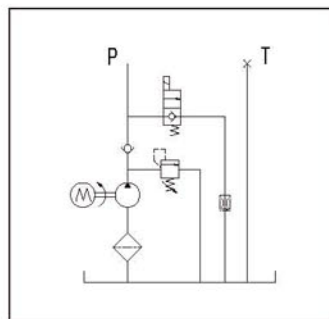

Y2

### 注意事项/SPECIAL NOTES

- 此动力单元为S3工作制，不可连续运转，10秒开，90秒停。
- 安装前必须保证油缸、油管、接头等液压元件无杂质黏附。
- 液压油粘度应为15-68ST，夏季推荐46号抗磨液压油，冬季推荐32号低温液压油。
- 首次启动运行系统后，应立即检查油箱中的油量是否充足，一般为油箱2/3部位。
- 系统使用第一个100小时后，应更换液压油，以后每3000小时更换一次液压油。
- The power unit is S3 working system and can not operate continuously. It starts in 10 seconds and stops in 90 seconds.
- Before installation, ensure that hydraulic components such as oil cylinder, oil pipe and joint are free of impurities.
- The viscosity of hydraulic oil shall be 15-68st. No. 46 anti-wear hydraulic oil is recommended in summer and No. 32 low temperature hydraulic oil is recommended in winter.
- After starting the operating system for the first time, check whether the oil in the oil tank is sufficient, generally 2 / 3 of the oil tank.
- After the system is used for the first 100 hours, the hydraulic oil shall be replaced, and then the hydraulic oil shall be replaced every 3000 hours.

### 产品配置/SPECIFICATIONS

型号 Model	电压 Volt	功率 Power	转速 Speed	油泵排量 Displacemet	工作压力 Pressure	油箱 Tank	电磁阀电压 Solenoid Vavle Volt
PNC-0.8-D24-0.5/0.65-16-1.5/L-Y2	24VDC	0.8KW	3400RPM	0.65CC/REV	16MPA	1.5L	24VDC
PNC-1.2-D24-0.5/0.88-16-1.5/L-Y2		1.2KW	3800RPM	0.88CC/REV			
PNC-0.8-D48-0.5/0.65-16-1.5/L-Y2	48VDC	0.8KW	3100RPM	0.65CC/REV			48VDC

说明：如需不同流量得泵、压力、电机功率等系统参数，请联系我司业务员。

Note: if you need system parameters such as pump, pressure and motor power with different flow, please contact our salesman.

## 半电动堆高车液压动力单元 STACKER FORK LIFT HYDRAULIC POWER UNIT

此液压动力单元专为半电动堆高车所设计。由高压齿轮泵、永磁直流电机、中心阀块、插装阀、油箱集成为一体。由控制手柄上的微动开关启动电机，实现上升，下降速度由操作手柄控制，常规采用12V电源控制。内置压力补偿节流阀控制下降速度。有铁制和塑料油箱可供选择。

This hydraulic power unit is specially designed for semi electric stacker. It is integrated by high-voltage gear pump, permanent magnet DC motor, central valve block, cartridge valve and oil tank. The motor is started by the microswitch on the control handle to realize the rise, and the descent speed is controlled by the operating handle, which is generally controlled by 12V power supply. The built-in pressure compensation throttle valve controls the descent speed. There are iron and plastic fuel tanks to choose from.



### 原理图/SCHEMATIC DIAGRAM

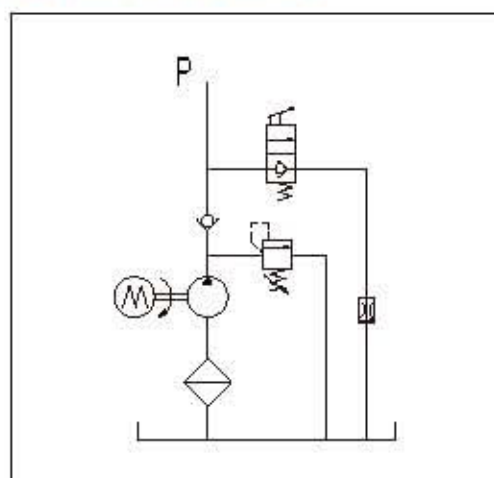

Y6

### 注意事项/SPECIAL NOTES

- 此动力单元为S3工作制，不可连续运转，10秒开，90秒停。
- 安装前必须保证油缸、油管、接头等液压元件无杂质黏附。
- 液压油粘度应为15-68ST，夏季推荐46号抗磨液压油，冬季推荐32号低温液压油。
- 首次启动运行系统后，应立即检查油箱中的油量是否充足，一般为油箱2/3部位。
- 系统使用第一个100小时后，应更换液压油，以后每3000小时更换一次液压油。
- The power unit is S3 working system and can not operate continuously. It starts in 10 seconds and stops in 90 seconds.
- Before installation, ensure that hydraulic components such as oil cylinder, oil pipe and joint are free of impurities.
- The viscosity of hydraulic oil shall be 15-68st. No. 46 anti-wear hydraulic oil is recommended in summer and No. 32 low temperature hydraulic oil is recommended in winter.
- After starting the operating system for the first time, check whether the oil in the oil tank is sufficient, generally 2 / 3 of the oil tank.
- After the system is used for the first 100 hours, the hydraulic oil shall be replaced, and then the hydraulic oil shall be replaced every 3000 hours.

### 产品配套/SPECIFICATIONS

型号 Model	电压 Volt	功率 Power	转速 Speed	油泵排量 Displacemet	工作压力 Pressure	油箱 Tank	电磁阀电压 Solenoid Vavle Volt
PNC-1.6-D12-1/2.1-20-5/L-Y6	12VDC	1.6KW	2800RPM	2.1CC/REV	20MPA	5L	NULL

说明：如需不同流量、压力、电机功率等系统参数，请联系我司业务员。

Note: if you need system parameters such as pump, pressure and motor power with different flow, please contact our salesman.

## 便携式堆高车动力单元 PORTABLE STACKER POWER UNIT

此液压动力单元专为便携式堆高车所设计。由高压齿轮泵、永磁直流电机、中心阀块、插装阀、油箱集成为一体。由电机和电磁阀控制双作用油缸上升和下降，电机功率采用0.8-1.2KW，有铁制和塑料油箱可供选择。

This hydraulic power unit is specially designed for portable stacker. It is integrated by high-voltage gear pump, permanent magnet DC motor, central valve block, cartridge valve and oil tank. The rise and fall of double acting oil cylinder are controlled by motor and solenoid valve, and the motor power is 0.8-1.2kw. There are iron and plastic fuel tanks to choose from.



### 原理图/SCHEMATIC DIAGRAM

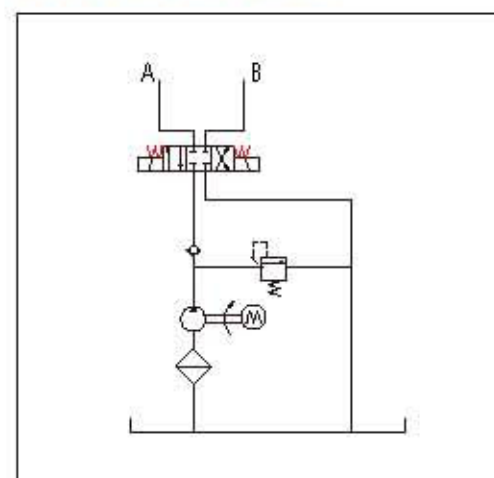

Y9

### 注意事项/SPECIAL NOTES

- 此动力单元为S3工作制，不可连续运转，10秒开，90秒停。
- 安装前必须保证油缸、油管、接头等液压元件无杂质黏附。
- 液压油粘度应为15-68ST，夏季推荐46号抗磨液压油，冬季推荐32号低温液压油。
- 首次启动运行系统后，应立即检查油箱中的油量是否充足，一般为油箱2/3部位。
- 系统使用第一个100小时后，应更换液压油，以后每3000小时更换一次液压油。
- The power unit is S3 working system and can not operate continuously. It starts in 10 seconds and stops in 90 seconds.
- Before installation, ensure that hydraulic components such as oil cylinder, oil pipe and joint are free of impurities.
- The viscosity of hydraulic oil shall be 15-68st. No. 46 anti-wear hydraulic oil is recommended in summer and No. 32 low temperature hydraulic oil is recommended in winter.
- After starting the operating system for the first time, check whether the oil in the oil tank is sufficient, generally 2 / 3 of the oil tank.
- After the system is used for the first 100 hours, the hydraulic oil shall be replaced, and then the hydraulic oil shall be replaced every 3000 hours.

### 产品配套/SPECIFICATIONS

型号 Model	电压 Volt	功率 Power	转速 Speed	油泵排量 Displacemet	工作压力 Pressure	油箱 Tank	电磁阀电压 Solenoid Vavle Volt
PNC-0.8-D12-0.5/1.25-10-2.5/L-Y9	12VDC	0.8KW	3100RPM	1.25CC/REV	10MPA	2.5L	12V
PNC-1.2-D12-0.5/1.5-12-2.5/L-Y9		1.2KW	3600RPM	1.5CC/REV	12MPA		

说明：如需不同流量、压力、电机功率等系统参数，请联系我司业务员。

Note: if you need system parameters such as pump, pressure and motor power with different flow, please contact our salesman.

## 全电动堆高车液压动力单元

HYDRAULIC POWER UNIT OF FULL ELECTRIC STACKER

此液压动力单元专为全电动堆高车所设计。由高压齿轮泵、直流碳刷电机、中心阀块、插装阀、油箱集成为一体。由电机和电磁阀控制上升和下降，具有从2.2KW-4KW电机功率可选，下降可选单速，双速，比例调速。有铁制和塑料油箱可供选择。

This hydraulic power unit is specially designed for all electric stacker. It is integrated by high-pressure gear pump, DC brush motor, central valve block, cartridge valve and oil tank. The rise and fall are controlled by motor and solenoid valve, with optional motor power from 2.2kw-4kw, single speed, double speed and proportional speed regulation. There are iron and plastic fuel tanks to choose from.

### 原理图/SCHEMATIC DIAGRAM

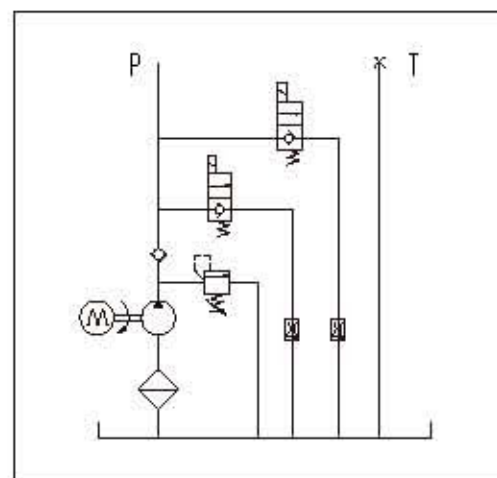

Y4

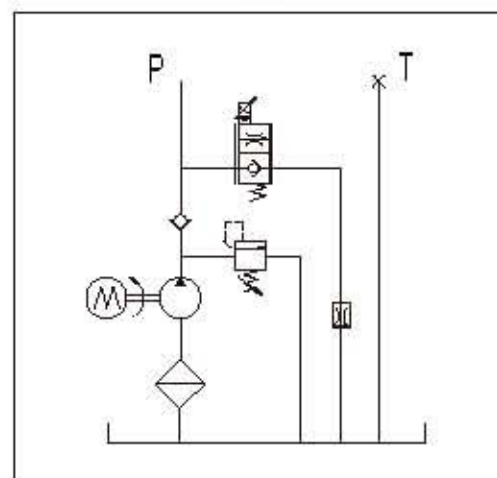

Y5



### 注意事项/SPECIAL NOTES

- 此动力单元为S3工作制，不可连续运转，10秒开，90秒停。
- 安装前必须保证油缸、油管、接头等液压元件无杂质黏附。
- 液压油粘度应为15-68ST，夏季推荐46号抗磨液压油，冬季推荐32号低温液压油。
- 首次启动运行系统后，应立即检查油箱中的油量是否充足，一般为油箱2/3部位。
- 系统使用第一个100小时后，应更换液压油，以后每3000小时更换一次液压油。
- The power unit is S3 working system and can not operate continuously. It starts in 10 seconds and stops in 90 seconds.
- Before installation, ensure that hydraulic components such as oil cylinder, oil pipe and joint are free of impurities.
- The viscosity of hydraulic oil shall be 15-68st. No. 46 anti-wear hydraulic oil is recommended in summer and No. 32 low temperature hydraulic oil is recommended in winter.
- After starting the operating system for the first time, check whether the oil in the oil tank is sufficient, generally 2/3 of the oil tank.
- After the system is used for the first 100 hours, the hydraulic oil shall be replaced, and then the hydraulic oil shall be replaced every 3000 hours.

### 产品配套/SPECIFICATIONS

型号 Model	电压 Volt	功率 Power	转速 Speed	油泵排量 Displacemet	工作压力 Pressure	油箱 Tank	电磁阀电压 Solenoid Vavle Volt
PNC-2.2-D24-1/2.7-20-5/L-Y2	24VDC	2.2KW	2600RPM	2.7CC/REV	20MPA	5L	24V
PNC-3-D24-1/3.2-20-10/L-Y4		3KW		3.2CC/REV		10L	
PNC-4-D24-1/3.5-20-10/L-Y5		4KW	3500RPM	3.5CC/REV			

说明：如需不同流量、压力、电机功率等系统参数，请联系我司业务员。

Note: if you need system parameters such as pump, pressure and motor power with different flow, please contact our salesman.

## 前移式堆高车动力单元

POWER UNIT OF FORWARD MOVING STACKER

此液压动力单元专为前移式堆高车所设计。由高压齿轮泵、直流碳刷或者无刷电机、中心阀块、插装阀、油箱集成为一体。一组控制单作用油缸升降，一组控制双作用油缸前后左右四个动作。具有从2.2KW-4KW电机功率可选，下降可选单速，双速，比例调速。有铁制和塑料油箱可供选择。

This hydraulic power unit is specially designed for the forward stacker. It is integrated by high-pressure gear pump, DC carbon brush or brushless motor, central valve block, cartridge valve and oil tank. One group controls the lifting of single acting oil cylinder, and the other group controls the front, rear, left and right actions of double acting oil cylinder. It has optional motor power from 2.2kw-4kw, single speed, double speed and proportional speed regulation. There are iron and plastic fuel tanks to choose from.

### 原理图/SCHEMATIC DIAGRAM



Y8



### 注意事项/SPECIAL NOTES

- 此动力单元为S3工作制，不可连续运转，10秒开，90秒停。
- 安装前必须保证油缸、油管、接头等液压元件无杂质黏附。
- 液压油粘度应为15-68ST，夏季推荐46号抗磨液压油，冬季推荐32号低温液压油。
- 首次启动运行系统后，应立即检查油箱中的油量是否充足，一般为油箱2/3部位。
- 系统使用第一个100小时后，应更换液压油，以后每3000小时更换一次液压油。
- The power unit is S3 working system and can not operate continuously. It starts in 10 seconds and stops in 90 seconds.
- Before installation, ensure that hydraulic components such as oil cylinder, oil pipe and joint are free of impurities.
- The viscosity of hydraulic oil shall be 15-68st. No. 46 anti-wear hydraulic oil is recommended in summer and No. 32 low temperature hydraulic oil is recommended in winter.
- After starting the operating system for the first time, check whether the oil in the oil tank is sufficient, generally 2/3 of the oil tank.
- After the system is used for the first 100 hours, the hydraulic oil shall be replaced, and then the hydraulic oil shall be replaced every 3000 hours.

### 产品配套/SPECIFICATIONS

型号 Model	电压 Volt	功率 Power	转速 Speed	油泵排量 Displacemet	工作压力 Pressure	油箱 Tank	电磁阀电压 Solenoid Vavle Volt
PNC-3-D24-1/3.2-20-10/L-Y8	24VDC	3KW	2600RPM	3.2CC/REV	20MPA	10L	24V
PNC-4-D24-1/3.7-20-10/L-Y8		4KW	3500RPM	3.7CC/REV			

说明：如需不同流量、压力、电机功率等系统参数，请联系我司业务员。

Note: if you need system parameters such as pump, pressure and motor power with different flow, please contact our salesman.

## 自卸式拖车动力单元

DUMP TRAILER POWER UNIT

此液压力单元专为自卸式拖车所设计。由高压齿轮泵、直流碳刷电机、中心阀块、插装阀、油箱集成为一体。依靠电机通电上升，负载自重下降，是典型的单作用原理。系统可选内置定速平衡阀，可选外置可调流量阀。有铁制和塑料油箱可供选择。

This hydraulic power unit is specially designed for dump trailers. It is integrated by high-pressure gear pump, DC carbon brush machine, central valve block, cartridge valve and oil tank. It is a typical single action principle to rely on the rise of motor power on and the decrease of load self weight. The system can be equipped with built-in constant speed balance valve and external adjustable flow valve. There are iron and plastic fuel tanks to choose from.



### 原理图/SCHEMATIC DIAGRAM

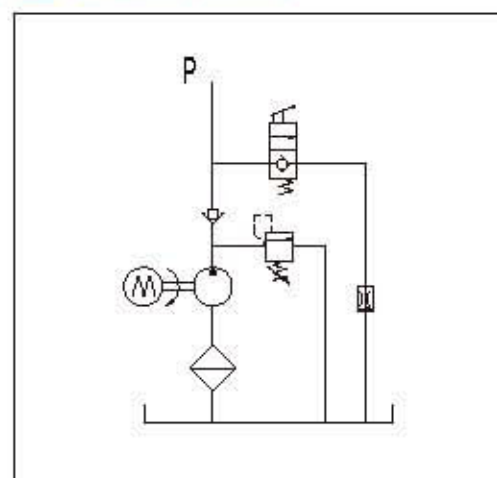

Y3

### 注意事项/SPECIAL NOTES

- 此动力单元为S3工作制，不可连续运转，10秒开，90秒停。
- 安装前必须保证油缸、油管、接头等液压元件无杂质黏附。
- 液压油粘度应为15-68ST，夏季推荐46号抗磨液压油，冬季推荐32号低温液压油。
- 首次启动运行系统后，应立即检查油箱中的油量是否充足，一般为油箱2/3部位。
- 系统使用第一个100小时后，应更换液压油，以后每3000小时更换一次液压油。
- The power unit is S3 working system and can not operate continuously. It starts in 10 seconds and stops in 90 seconds.
- Before installation, ensure that hydraulic components such as oil cylinder, oil pipe and joint are free of impurities.
- The viscosity of hydraulic oil shall be 15-68st. No. 46 anti-wear hydraulic oil is recommended in summer and No. 32 low temperature hydraulic oil is recommended in winter.
- After starting the operating system for the first time, check whether the oil in the oil tank is sufficient, generally 2/3 of the oil tank.
- After the system is used for the first 100 hours, the hydraulic oil shall be replaced, and then the hydraulic oil shall be replaced every 3000 hours.

### 产品配置/SPECIFICATIONS

型号 Model	电压 Volt	功率 Power	转速 Speed	油泵排量 Displacemet	工作压力 Pressure	油箱 Tank	电磁阀电压 Solenoid Vavle Volt
PNC-1.6-D12-1/2.1-20-8/W-Y3	12VDC	1.6KW	2800RPM	2.1CC/REV	20MPA	8L	12V
PNC-2.2-D24-1/3.2-20-10/W-Y3	24VDC	2.2KW	2600RPM	3.2CC/REV		10L	24V

说明：如需不同流量、压力、电机功率等系统参数，请联系我司业务员。

Note: if you need system parameters such as pump, pressure and motor power with different flow, please contact our salesman.

## 液压尾板动力单元

HYDRAULIC TAILBOARD POWER UNIT

此液压力单元专为液压尾板所设计。车辆尾板液压力单元是用于箱式货车尾板控制的动力装置，此系列液压力单元通过常闭电磁阀和电磁止回阀实现尾板举升、关门、下降、开门等动作，完成货物的装卸工作下降速度可通过节流阀进行调节。有12和24V电压可选。

This hydraulic power unit is specially designed for the hydraulic tail plate. The vehicle tail plate hydraulic power unit is a power unit used for the control of the tail plate of the box truck. This series of hydraulic power units realize the actions of lifting, closing, lowering and opening the tail plate through the normally closed solenoid valve and solenoid check valve, complete the loading and unloading of goods, and the lowering speed can be adjusted through the throttle valve. 12 and 24V voltages are available.



### 原理图/SCHEMATIC DIAGRAM

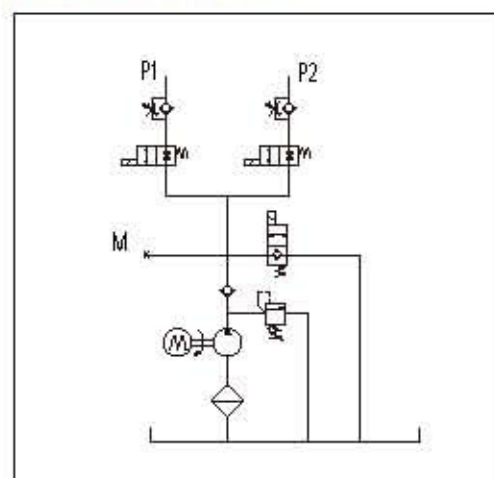

Y17

### 注意事项/SPECIAL NOTES

- 此动力单元为S3工作制，不可连续运转，10秒开，90秒停。
- 安装前必须保证油缸、油管、接头等液压元件无杂质黏附。
- 液压油粘度应为15-68ST，夏季推荐46号抗磨液压油，冬季推荐32号低温液压油。
- 首次启动运行系统后，应立即检查油箱中的油量是否充足，一般为油箱2/3部位。
- 系统使用第一个100小时后，应更换液压油，以后每3000小时更换一次液压油。
- The power unit is S3 working system and can not operate continuously. It starts in 10 seconds and stops in 90 seconds.
- Before installation, ensure that hydraulic components such as oil cylinder, oil pipe and joint are free of impurities.
- The viscosity of hydraulic oil shall be 15-68st. No. 46 anti-wear hydraulic oil is recommended in summer and No. 32 low temperature hydraulic oil is recommended in winter.
- After starting the operating system for the first time, check whether the oil in the oil tank is sufficient, generally 2/3 of the oil tank.
- After the system is used for the first 100 hours, the hydraulic oil shall be replaced, and then the hydraulic oil shall be replaced every 3000 hours.

### 产品配置/SPECIFICATIONS

型号 Model	电压 Volt	功率 Power	转速 Speed	油泵排量 Displacemet	工作压力 Pressure	油箱 Tank	电磁阀电压 Solenoid Vavle Volt
PNC-1.6-D12-1/1.7-20-10/WB-Y17	12VDC	1.6KW	2800RPM	1.7CC/REV	20MPA	10L	12V
PNC-2.2-D24-1/2.5-20-10/WB-Y17		2.2KW	2600RPM	2.5CC/REV			24V

说明：如需不同流量、压力、电机功率等系统参数，请联系我司业务员。

Note: if you need system parameters such as pump, pressure and motor power with different flow, please contact our salesman.

## 直流电动泵

DC MOTOR PUMP STATION

此液压泵站由1系列侧进侧出齿轮泵与4.5或者5英寸直流电机组成，性能稳定，常作为液压动力源广泛应用于各种移动设备液压系统。电压有12-48V可选。

This hydraulic pump station is composed of a series of side inlet and side outlet gear pumps and 4.5 or 5-inch DC motors. It is often used as a hydraulic power source and is widely used in the hydraulic system of various mobile equipment. The voltage can be 12-48V.



### 原理图/SCHEMATIC DIAGRAM

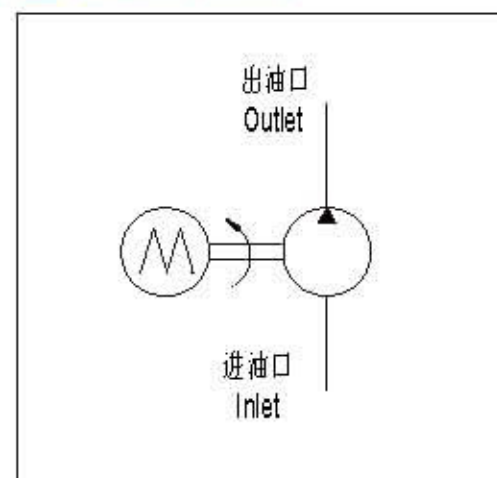

Y0

### 注意事项/SPECIAL NOTES

- 此动力单元为S3工作制，不可连续运转，10秒开，90秒停。
- 安装前必须保证油缸、油管、接头等液压元件无杂质黏附。
- 液压油粘度应为15-68ST，夏季推荐46号抗磨液压油，冬季推荐32号低温液压油。
- 首次启动运行系统后，应立即检查油箱中的油量是否充足，一般为油箱2/3部位。
- 系统使用第一个100小时后，应更换液压油，以后每3000小时更换一次液压油。
- The power unit is S3 working system and can not operate continuously. It starts in 10 seconds and stops in 90 seconds.
- Before installation, ensure that hydraulic components such as oil cylinder, oil pipe and joint are free of impurities.
- The viscosity of hydraulic oil shall be 15-68st. No. 46 anti-wear hydraulic oil is recommended in summer and No. 32 low temperature hydraulic oil is recommended in winter.
- After starting the operating system for the first time, check whether the oil in the oil tank is sufficient, generally 2/3 of the oil tank.
- After the system is used for the first 100 hours, the hydraulic oil shall be replaced, and then the hydraulic oil shall be replaced every 3000 hours.

### 产品配置/SPECIFICATIONS

型号 Model	电压 Volt	功率 Power	转速 Speed	油泵排量 Displacemet	工作压力 Pressure	油箱 Tank	电磁阀电压 Solenoid Vavle Volt
PNC-1.6-D12-1/1.6-20-Y0	12VDC	1.6KW	2800RPM	1.6CC/REV	20MPA	NULL	12VDC
PNC-2.2-D24-1/2.7-20-Y0	24VDC	2.2KW	2600RPM	2.7CC/REV			24VDC
PNC-3.0-D24-1/3.2-20-Y0		3.0KW		3.2CC/REV			24VDC
PNC-2.0-D48-1/2.7-20-Y0	48VDC	2.0KW	2800RPM	2.7CC/REV			48VDC

说明：如需不同流量、压力、电机功率等系统参数，请联系我司业务员。

Note: if you need system parameters such as pump, pressure and motor power with different flow, please contact our salesman.

## 高空作业车电动泵

AERIAL VEHICLE ELECTRIC PUMP

此液压泵站专为自行高空作业车设计，由2系列侧进侧出齿轮泵与大功率直流电机组成，配合进口的插装阀组使用，性能稳定，常作为液压动力源广泛应用于各种移动设备液压系统。电压有24-48V可选。

This hydraulic pump station is specially designed for self-propelled aerial work vehicle. It is composed of 2 series side inlet and side outlet gear pump and high-power DC motor. It is used with imported cartridge valve group. It has stable performance. It is often used as a hydraulic power source and is widely used in the hydraulic system of various mobile equipment. The voltage can be 24-48V.



### 原理图/SCHEMATIC DIAGRAM

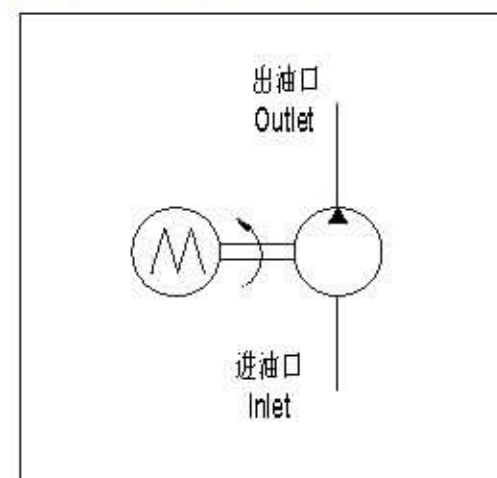

Y0

### 注意事项/SPECIAL NOTES

- 此动力单元为S3工作制，不可连续运转，10秒开，90秒停。
- 安装前必须保证油缸、油管、接头等液压元件无杂质黏附。
- 液压油粘度应为15-68ST，夏季推荐46号抗磨液压油，冬季推荐32号低温液压油。
- 首次启动运行系统后，应立即检查油箱中的油量是否充足，一般为油箱2/3部位。
- 系统使用第一个100小时后，应更换液压油，以后每3000小时更换一次液压油。
- The power unit is S3 working system and can not operate continuously. It starts in 10 seconds and stops in 90 seconds.
- Before installation, ensure that hydraulic components such as oil cylinder, oil pipe and joint are free of impurities.
- The viscosity of hydraulic oil shall be 15-68st. No. 46 anti-wear hydraulic oil is recommended in summer and No. 32 low temperature hydraulic oil is recommended in winter.
- After starting the operating system for the first time, check whether the oil in the oil tank is sufficient, generally 2/3 of the oil tank.
- After the system is used for the first 100 hours, the hydraulic oil shall be replaced, and then the hydraulic oil shall be replaced every 3000 hours.

### 产品配置/SPECIFICATIONS

型号 Model	电压 Volt	功率 Power	转速 Speed	油泵排量 Displacemet	工作压力 Pressure	油箱 Tank	电磁阀电压 Solenoid Vavle Volt
PNC-4.5-D24-2/4.2-20-Y0	24VDC	4.5KW	2700RPM	4.2CC/REV	20MPA	NULL	24V
PNC-4.5-D48-2/4.2-20-Y0	48VDC						48V

说明：如需不同流量、压力、电机功率等系统参数，请联系我司业务员。

Note: if you need system parameters such as pump, pressure and motor power with different flow, please contact our salesman.

## 电动叉车动力单元

## POWER UNIT OF ELECTRIC JIB FORKLIFT

此液压力单元专为电动叉车设计，由高压齿轮泵、永磁直流电机、中心阀块、插装阀、油箱集成于一体。启动电机，实现上升，打开电磁阀，实现下降。内置压力补偿节流阀控制下降速度。具有重量轻，安装空间小等特点，有0.5-0.8KW可选电机，电压12-48V可选，有铁制和塑料油箱可供选择。

This hydraulic power unit is specially designed for electric forklift. It is integrated by high-pressure gear pump, permanent magnet DC motor, central valve block, cartridge valve and oil tank. Start the motor to rise and open the solenoid valve to fall. The built-in pressure compensation throttle valve controls the descent speed. It has the characteristics of light weight and small installation space. There are 0.3-0.8kw optional motors, 12-48v optional voltages, and iron and plastic oil tanks to choose from.



## 原理图/SCHEMATIC DIAGRAM

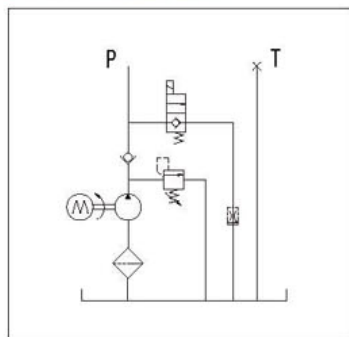

Y2

## 注意事项/SPECIAL NOTES

- 此动力单元为S3工作制，不可连续运转，10秒开，90秒停。
- 安装前必须保证油缸、油管、接头等液压元件无杂质黏附。
- 液压油粘度应为15-68ST，夏季推荐46号抗磨液压油，冬季推荐32号低温液压油。
- 首次启动运行系统后，应立即检查油箱中的油量是否充足，一般为油箱2/3部位。
- 系统使用第一个100小时后，应更换液压油，以后每3000小时更换一次液压油。
- The power unit is S3 working system and can not operate continuously. It starts in 10 seconds and stops in 90 seconds.
- Before installation, ensure that hydraulic components such as oil cylinder, oil pipe and joint are free of impurities.
- The viscosity of hydraulic oil shall be 15-68st. No. 46 anti-wear hydraulic oil is recommended in summer and No. 32 low temperature hydraulic oil is recommended in winter.
- After starting the operating system for the first time, check whether the oil in the oil tank is sufficient, generally 2 / 3 of the oil tank.
- After the system is used for the first 100 hours, the hydraulic oil shall be replaced, and then the hydraulic oil shall be replaced every 3000 hours.

## 产品配置/SPECIFICATIONS

型号 Model	电压 Volt	功率 Power	转速 Speed	油泵排量 Displacemet	工作压力 Pressure	油箱 Tank	电磁阀电压 Solenoid Valve Volt
PNC-0.5-D12-0.5/0.38-16-1/W-Y2	12VDC	0.5KW	2800RPM	0.38CC/REV	16MPA	1L	24VDC
PNC-0.8-D12-0.5/0.65-16-1/W-Y2		0.8KW	3100RPM	0.65CC/REV			
PNC-0.5-D24-0.5/0.38-16-1/W-Y2	24VDC	0.5KW	2800RPM	0.38CC/REV			
PNC-0.8-D24-0.5/0.65-16-1/W-Y2		0.8KW	3400RPM	0.65CC/REV			
PNC-0.8-D48-0.5/0.65-16-1/W-Y2	48VDC	0.8KW	3100RPM	0.65CC/REV			48VDC

说明：如需不同流量得泵、压力、电机功率等系统参数，请联系我司业务员。

Note: if you need system parameters such as pump, pressure and motor power with different flow, please contact our salesman.

## 移动式升降平台动力单元

## MOBILE LIFTING PLATFORM POWER UNIT

此液压力单元专为移动式液压升降台设计，由高压齿轮泵、永磁直流电机、中心阀块、插装阀、油箱集成于一体。启动电机，实现上升，打开电磁阀，实现下降。内置压力补偿节流阀控制下降速度。具有重量轻，安装空间小等特点，有0.8-1.6KW可选电机，电压12-24V可选，有铁制和塑料油箱可供选择。

This hydraulic power unit is specially designed for mobile hydraulic lifting platform. It is integrated by high-pressure gear pump, permanent magnet DC motor, central valve block, cartridge valve and oil tank. Start the motor to rise and open the solenoid valve to fall. The built-in pressure compensation throttle valve controls the descent speed. It has the characteristics of light weight and small installation space. There are 0.8-1.6kw optional motors, 12-24v optional voltages, and iron and plastic oil tanks to choose from.



## 原理图/SCHEMATIC DIAGRAM

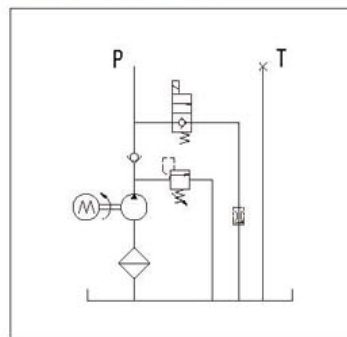

Y2

## 注意事项/SPECIAL NOTES

- 此动力单元为S3工作制，不可连续运转，10秒开，90秒停。
- 安装前必须保证油缸、油管、接头等液压元件无杂质黏附。
- 液压油粘度应为15-68ST，夏季推荐46号抗磨液压油，冬季推荐32号低温液压油。
- 首次启动运行系统后，应立即检查油箱中的油量是否充足，一般为油箱2/3部位。
- 系统使用第一个100小时后，应更换液压油，以后每3000小时更换一次液压油。
- The power unit is S3 working system and can not operate continuously. It starts in 10 seconds and stops in 90 seconds.
- Before installation, ensure that hydraulic components such as oil cylinder, oil pipe and joint are free of impurities.
- The viscosity of hydraulic oil shall be 15-68st. No. 46 anti-wear hydraulic oil is recommended in summer and No. 32 low temperature hydraulic oil is recommended in winter.
- After starting the operating system for the first time, check whether the oil in the oil tank is sufficient, generally 2 / 3 of the oil tank.
- After the system is used for the first 100 hours, the hydraulic oil shall be replaced, and then the hydraulic oil shall be replaced every 3000 hours.

## 产品配置/SPECIFICATIONS

型号 Model	电压 Volt	功率 Power	转速 Speed	油泵排量 Displacemet	工作压力 Pressure	油箱 Tank	电磁阀电压 Solenoid Valve Volt
PNC-1.2-D12-0.5/0.65-20-3/L-Y2	12VDC	0.8KW	3100RPM	0.38CC/REV	20MPA	3L	12VDC
		1.2KW	2800RPM	0.65CC/REV			
		1.6KW	2600RPM	1.6CC/REV			

说明：如需不同流量得泵、压力、电机功率等系统参数，请联系我司业务员。

Note: if you need system parameters such as pump, pressure and motor power with different flow, please contact our salesman.

## 直流双向泵动力单元

### DC BIDIRECTIONAL PUMP POWER UNIT

此动力单元由双向齿轮泵、永磁直流电机、中心块、插装阀组件、油箱等多个零部件组成，这种动力单元在没有电磁阀的情况下，依靠电机正反转实现换向的功能，这就使得该动力单元体积小，适用于各类布局空间较小的设备。同时该动力单元结构紧凑、性能稳定，被广泛应用于行走车辆、升降平台等设备。电机电压12-48V可选。

This power unit is composed of bidirectional gear pump, permanent magnet DC motor, center block, cartridge valve assembly, oil tank and other parts. Without solenoid valve, this power unit realizes the reversing function by relying on the forward and reverse rotation of motor, which makes the power unit compact and suitable for all kinds of equipment with small layout space. At the same time, the power unit has compact structure and stable performance, and is widely used in walking vehicles, lifting platforms and other equipment. Motor voltage 12-48V optional.



### 原理图/SCHEMATIC DIAGRAM

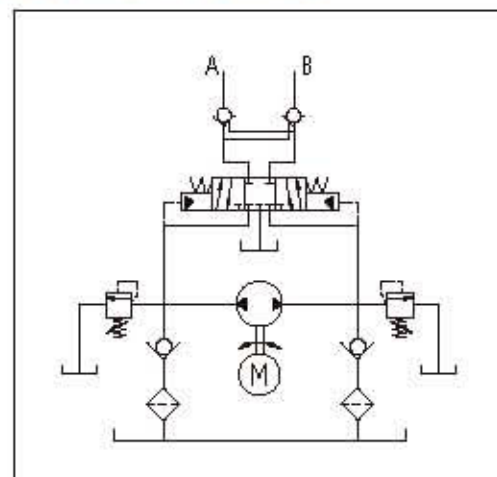

Y14

### 注意事项/SPECIAL NOTES

- 此动力单元为S3工作制，不可连续运转，10秒开，90秒停。
- 安装前必须保证油缸、油管、接头等液压元件无杂质黏附。
- 液压油粘度应为15-68ST，夏季推荐46号抗磨液压油，冬季推荐32号低温液压油。
- 首次启动运行系统后，应立即检查油箱中的油量是否充足，一般为油箱2/3部位。
- 系统使用第一个100小时后，应更换液压油，以后每3000小时更换一次液压油。

- The power unit is S3 working system and can not operate continuously. It starts in 10 seconds and stops in 90 seconds.
- Before installation, ensure that hydraulic components such as oil cylinder, oil pipe and joint are free of impurities.
- The viscosity of hydraulic oil shall be 15-68st. No. 46 anti-wear hydraulic oil is recommended in summer and No. 32 low temperature hydraulic oil is recommended in winter.
- After starting the operating system for the first time, check whether the oil in the oil tank is sufficient, generally 2 / 3 of the oil tank.
- After the system is used for the first 100 hours, the hydraulic oil shall be replaced, and then the hydraulic oil shall be replaced every 3000 hours.

### 产品配套/SPECIFICATIONS

型号 Model	电压 Volt	功率 Power	转速 Speed	油泵排量 Displacemet	工作压力 Pressure	油箱 Tank	电磁阀电压 Solenoid Valve Volt
PNC-0.5-D12-0.5T/0.65-14-1/L-Y14	12VDC	0.5KW	2800RPM	0.65CC/REV	14MPA	1L	12VDC
PNC-0.8-D24-0.5T/1.0-14-3/W-Y14	24VDC	0.8KW	3100RPM	1.0CC/REV		3L	24VDC
PNC-0.8-D24-0.5T/1.0-14-3/W-Y14	48VDC					48VDC	

说明：如需不同流量、压力、电机功率等系统参数，请联系我司业务员。

Note: if you need system parameters such as pump, pressure and motor power with different flow, please contact our salesman.

## 直流单作用动力单元

### MOBILE LIFTING PLATFORM POWER UNIT

此液压动力单元由高压齿轮泵、直流电机、中心阀块、插装阀、油箱集成为一体。一般适用于双作用液压缸，可叠加液压锁，调速阀实现各种功能，通过电磁阀实现换向，整体性能稳定，广泛适用于汽车、园林机械、物流设备等。有0.3-4KW可选电机，电压12-48V可选，有铁制和塑料油箱可供选择。

The hydraulic power unit is integrated by high-pressure gear pump, DC motor, central valve block, cartridge valve and oil tank. It is generally applicable to double acting hydraulic cylinder, can stack hydraulic lock, speed regulating valve to realize various functions, and realize commutation through solenoid valve. The overall performance is stable. It is widely applicable to automobile, garden machinery, logistics equipment, etc. There are 0.3-4kw optional motors, 12-48v optional voltages, and iron and plastic oil tanks to choose from.



### 原理图/SCHEMATIC DIAGRAM

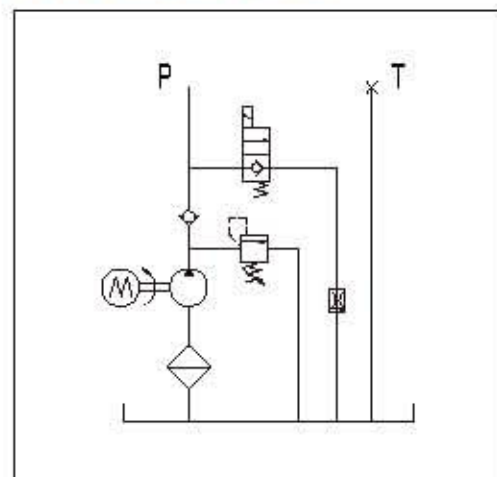

Y2

### 注意事项/SPECIAL NOTES

- 此动力单元为S3工作制，不可连续运转，10秒开，90秒停。
- 安装前必须保证油缸、油管、接头等液压元件无杂质黏附。
- 液压油粘度应为15-68ST，夏季推荐46号抗磨液压油，冬季推荐32号低温液压油。
- 首次启动运行系统后，应立即检查油箱中的油量是否充足，一般为油箱2/3部位。
- 系统使用第一个100小时后，应更换液压油，以后每3000小时更换一次液压油。

- The power unit is S3 working system and can not operate continuously. It starts in 10 seconds and stops in 90 seconds.
- Before installation, ensure that hydraulic components such as oil cylinder, oil pipe and joint are free of impurities.
- The viscosity of hydraulic oil shall be 15-68st. No. 46 anti-wear hydraulic oil is recommended in summer and No. 32 low temperature hydraulic oil is recommended in winter.
- After starting the operating system for the first time, check whether the oil in the oil tank is sufficient, generally 2 / 3 of the oil tank.
- After the system is used for the first 100 hours, the hydraulic oil shall be replaced, and then the hydraulic oil shall be replaced every 3000 hours.

### 产品配套/SPECIFICATIONS

型号 Model	电压 Volt	功率 Power	转速 Speed	油泵排量 Displacemet	工作压力 Pressure	油箱 Tank	电磁阀电压 Solenoid Valve Volt
PNC-1.6-D12-1/1.6-20-5/L-Y2	12VDC	1.6KW	2800RPM	1.6CC/REV	18MPA	5L	12VDC
PNC-2.2-D24-1/2.7-20-6/L-Y2	24VDC	2.2KW	2600RPM	2.7CC/REV		6L	24VDC
PNC-3.0-D24-1/3.2-20-8/L-Y2		3.0KW		3.2CC/REV		8L	

说明：如需不同流量、压力、电机功率等系统参数，请联系我司业务员。

Note: if you need system parameters such as pump, pressure and motor power with different flow, please contact our salesman.

## 直流双作用动力单元

### DC BIDIRECTIONAL PUMP POWER UNIT

此液压力单元由高压齿轮泵、直流电机、中心阀块、插装阀、油箱集成为一体。一般适用于双作用液压缸，可叠加液锁，调速阀实现各种功能，通过电磁阀实现换向，整体性能稳定，广泛适用于汽车、园林机械、物流设备等。有0.3-4KW可选电机，电压12-48V可选，有铁制和塑料油箱可供选择。

This power unit is composed of bidirectional gear pump, permanent magnet DC motor, center block, cartridge valve assembly, oil tank and other parts. Without solenoid valve, this power unit realizes the reversing function by relying on the forward and reverse rotation of motor, which makes the power unit compact and suitable for all kinds of equipment with small layout space. At the same time, the power unit has compact structure and stable performance, and is widely used in walking vehicles, lifting platforms and other equipment. Motor voltage 12-48v optional.



### 原理图/SCHEMATIC DIAGRAM

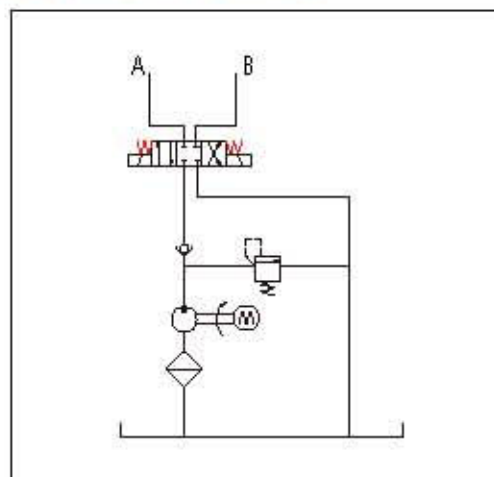

Y9

### 注意事项/SPECIAL NOTES

- 此动力单元为S3工作制，不可连续运转，10秒开，90秒停。
- 安装前必须保证油缸、油管、接头等液压元件无杂质黏附。
- 液压油粘度应为15-68ST，夏季推荐46号抗磨液压油，冬季推荐32号低温液压油。
- 首次启动运行系统后，应立即检查油箱中的油量是否充足，一般为油箱2/3部位。
- 系统使用第一个100小时后，应更换液压油，以后每3000小时更换一次液压油。

- The power unit is S3 working system and can not operate continuously. It starts in 10 seconds and stops in 90 seconds.
- Before installation, ensure that hydraulic components such as oil cylinder, oil pipe and joint are free of impurities.
- The viscosity of hydraulic oil shall be 15-68st. No. 46 anti-wear hydraulic oil is recommended in summer and No. 32 low temperature hydraulic oil is recommended in winter.
- After starting the operating system for the first time, check whether the oil in the oil tank is sufficient, generally 2 / 3 of the oil tank.
- After the system is used for the first 100 hours, the hydraulic oil shall be replaced, and then the hydraulic oil shall be replaced every 3000 hours.

### 产品配套/SPECIFICATIONS

型号 Model	电压 Volt	功率 Power	转速 Speed	油泵排量 Displacemet	工作压力 Pressure	油箱 Tank	电磁阀电压 Solenoid Vavle Volt
PNC-1.6-D12-1/1.6-20-5/L-Y9	12VDC	1.6KW	2800RPM	1.6CC/REV	18MPA	5L	12VDC
PNC-2.2-D24-1/2.7-20-6/L-Y9	24VDC	2.2KW	2600RPM	2.7CC/REV		6L	24VDC
PNC-3.0-D24-1/3.2-20-8/L-Y9		3.0KW		3.2CC/REV		8L	

说明：如需不同流量、压力、电机功率等系统参数，请联系我司业务员。

Note: if you need system parameters such as pump, pressure and motor power with different flow, please contact our salesman.

## 直流微型动力单元

### DC MICRO POWER UNIT

此液压力单元由高压齿轮泵、直流电机、中心阀块、插装阀、油箱集成为一体。一般适用于双作用液压缸，采用插装式电磁换向阀实现液压缸的往复工作。由于体积小，易安装，整体性能稳定，因此广泛应用于船舶、汽车、园林机械、物流设备等。有0.3-0.5KW可选电机，电压12-48V可选，有铁制和塑料油箱可供选择。

The hydraulic power unit is integrated by high-pressure gear pump, DC motor, central valve block, cartridge valve and oil tank. It is generally applicable to double acting hydraulic cylinder, and the plug-in electromagnetic directional valve is used to realize the reciprocating work of hydraulic cylinder. Because of its small size, easy installation and stable overall performance, it is widely used in ships, automobiles, garden machinery, logistics equipment, etc. There are 0.3-5kw optional motors, 12-48v optional voltages, and iron and plastic oil tanks to choose from.



### 原理图/SCHEMATIC DIAGRAM

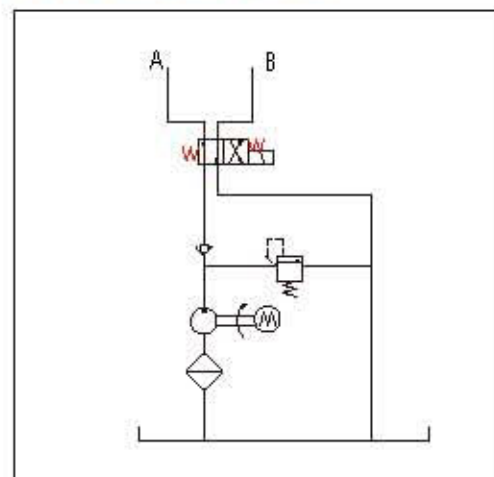

Y18

### 注意事项/SPECIAL NOTES

- 此动力单元为S3工作制，不可连续运转，10秒开，90秒停。
- 安装前必须保证油缸、油管、接头等液压元件无杂质黏附。
- 液压油粘度应为15-68ST，夏季推荐46号抗磨液压油，冬季推荐32号低温液压油。
- 首次启动运行系统后，应立即检查油箱中的油量是否充足，一般为油箱2/3部位。
- 系统使用第一个100小时后，应更换液压油，以后每3000小时更换一次液压油。

- The power unit is S3 working system and can not operate continuously. It starts in 10 seconds and stops in 90 seconds.
- Before installation, ensure that hydraulic components such as oil cylinder, oil pipe and joint are free of impurities.
- The viscosity of hydraulic oil shall be 15-68st. No. 46 anti-wear hydraulic oil is recommended in summer and No. 32 low temperature hydraulic oil is recommended in winter.
- After starting the operating system for the first time, check whether the oil in the oil tank is sufficient, generally 2 / 3 of the oil tank.
- After the system is used for the first 100 hours, the hydraulic oil shall be replaced, and then the hydraulic oil shall be replaced every 3000 hours.

### 产品配套/SPECIFICATIONS

型号 Model	电压 Volt	功率 Power	转速 Speed	油泵排量 Displacemet	工作压力 Pressure	油箱 Tank	电磁阀电压 Solenoid Vavle Volt
PNC-0.3-D12-0.5/0.19-14-1/W-Y18	12VDC	0.3KW	3000RPM	0.19CC/REV	14MPA	1L	12VDC
PNC-0.3-D24-0.5/0.19-14-1/W-Y18	24VDC			0.26CC/REV			24VDC
PNC-0.5-D48-0.5/0.38-14-1/W-Y18	48VDC	0.5KW	2800RPM	0.38CC/REV			48VDC

说明：如需不同流量、压力、电机功率等系统参数，请联系我司业务员。

Note: if you need system parameters such as pump, pressure and motor power with different flow, please contact our salesman.

## 登车桥动力单元A

### BOARDING AXLE POWER UNIT A

此液压动力单元专为固定式登车桥设计，由高压齿轮泵、交流电机、中心阀块、插装阀、油箱集成于一体。启动电机，实现主板上升，当主板压力达到顺序阀设计压力后，打开唇板。主板和唇板的下降由自重控制。可调主板的下降速度，使下降速度在可靠的范围内。有0.75-1.5KW可选电机，电压220-380V可选，有铁制和塑料油箱可供选择。

This hydraulic power unit is specially designed for fixed boarding axle and is integrated by high-pressure gear pump, AC motor, central valve block, cartridge valve and oil tank. Start the motor to realize the rise of the main board. When the pressure of the main board reaches the design pressure of the sequence valve, open the lip plate. The lowering of main board and lip is controlled by self weight. The descending speed of the main board can be adjusted to make the descending speed within a reliable range. There are 0.75-1.5kw optional motors, 220-380v optional voltages, and iron and plastic oil tanks to choose from.



### 原理图/SCHEMATIC DIAGRAM

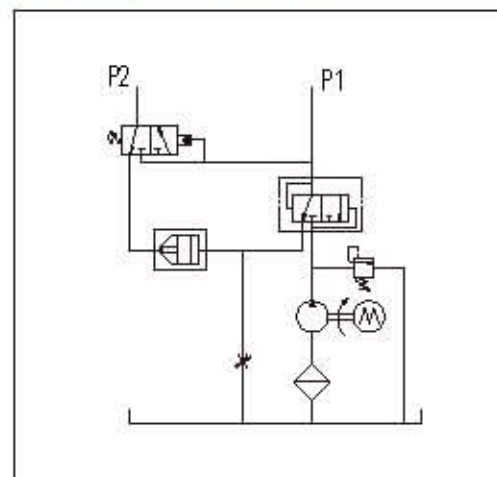

Y15

### 注意事项/SPECIAL NOTES

- 此动力单元为S3工作制，不可连续运转，10秒开，90秒停。
- 安装前必须保证油缸、油管、接头等液压元件无杂质黏附。
- 液压油粘度应为15-68ST，夏季推荐46号抗磨液压油，冬季推荐32号低温液压油。
- 首次启动运行系统后，应立即检查油箱中的油量是否充足，一般为油箱2/3部位。
- 系统使用第一个100小时后，应更换液压油，以后每3000小时更换一次液压油。

- The power unit is S3 working system and can not operate continuously. It starts in 10 seconds and stops in 90 seconds.
- Before installation, ensure that hydraulic components such as oil cylinder, oil pipe and joint are free of impurities.
- The viscosity of hydraulic oil shall be 15-68st. No. 46 anti-wear hydraulic oil is recommended in summer and No. 32 low temperature hydraulic oil is recommended in winter.
- After starting the operating system for the first time, check whether the oil in the oil tank is sufficient, generally 2 / 3 of the oil tank.
- After the system is used for the first 100 hours, the hydraulic oil shall be replaced, and then the hydraulic oil shall be replaced every 3000 hours.

### 产品配套/SPECIFICATIONS

型号 Model	电压 Volt	功率 Power	转速 Speed	油泵排量 Displacemet	工作压力 Pressure	油箱 Tank	电磁阀电压 Solenoid Vavle Volt
PNC-0.75-A380-2P-1/1.6-15-5/W-Y15	380VAC	0.75KW	2800RPM	1.6CC/REV	15MPA	5L	NULL
PNC-1.1-A220/S-4P-1/3.2-15-5/W-Y15	220VAC	1.1KW	1400RPM	3.2CC/REV			
PNC-1.1-A380-4P-1/4.2-15-6/W-Y15	380VAC			4.2CC/REV			

说明：如需不同流量、压力、电机功率等系统参数，请联系我司业务员。

Note: if you need system parameters such as pump, pressure and motor power with different flow, please contact our salesman.

## 登车桥动力单元B

### BOARDING AXLE POWER UNIT B

此液压动力单元专为固定式登车桥设计，由高压齿轮泵、交流电机、中心阀块、插装阀、油箱集成于一体。启动电机，实现主板上升，当主板压力达到顺序阀设计压力后，打开唇板。主板和唇板的下降由自重控制，增加电磁阀功能可实现任意位置停止。可调主板的下降速度，使下降速度在可靠的范围内。有0.75-1.5KW可选电机，电压220-380V可选，有铁制和塑料油箱可供选择。

This hydraulic power unit is specially designed for fixed boarding axle and is integrated by high-pressure gear pump, AC motor, central valve block, cartridge valve and oil tank. Start the motor to realize the rise of the main board. When the pressure of the main board reaches the design pressure of the sequence valve, open the lip plate. The lowering of the main board and the lip plate is controlled by the self weight, and the stop at any position can be realized by adding the solenoid valve function. The descending speed of the main board can be adjusted to make the descending speed within a reliable range. There are 0.75-1.5kw optional motors, 220-380v optional voltages, and iron and plastic oil tanks to choose from.



### 原理图/SCHEMATIC DIAGRAM

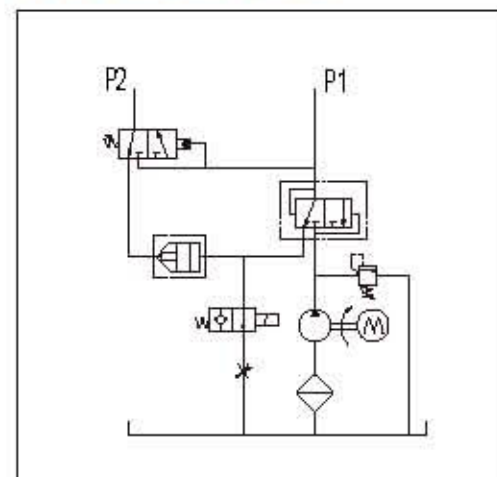

Y16

### 注意事项/SPECIAL NOTES

- 此动力单元为S3工作制，不可连续运转，10秒开，90秒停。
- 安装前必须保证油缸、油管、接头等液压元件无杂质黏附。
- 液压油粘度应为15-68ST，夏季推荐46号抗磨液压油，冬季推荐32号低温液压油。
- 首次启动运行系统后，应立即检查油箱中的油量是否充足，一般为油箱2/3部位。
- 系统使用第一个100小时后，应更换液压油，以后每3000小时更换一次液压油。

- The power unit is S3 working system and can not operate continuously. It starts in 10 seconds and stops in 90 seconds.
- Before installation, ensure that hydraulic components such as oil cylinder, oil pipe and joint are free of impurities.
- The viscosity of hydraulic oil shall be 15-68st. No. 46 anti-wear hydraulic oil is recommended in summer and No. 32 low temperature hydraulic oil is recommended in winter.
- After starting the operating system for the first time, check whether the oil in the oil tank is sufficient, generally 2 / 3 of the oil tank.
- After the system is used for the first 100 hours, the hydraulic oil shall be replaced, and then the hydraulic oil shall be replaced every 3000 hours.

### 产品配套/SPECIFICATIONS

型号 Model	电压 Volt	功率 Power	转速 Speed	油泵排量 Displacemet	工作压力 Pressure	油箱 Tank	电磁阀电压 Solenoid Vavle Volt
PNC-0.75-A380-2P-1/1.6-15-5/W-Y16	380VAC	0.75KW	2800RPM	1.6CC/REV	15MPA	5L	24VDC
PNC-1.1-A220/S-4P-1/3.2-15-5/W-Y16	220VAC	1.1KW	1400RPM	3.2CC/REV			
PNC-1.1-A380-2P-1/4.2-15-6/W-Y16	380VAC			4.2CC/REV			

说明：如需不同流量、压力、电机功率等系统参数，请联系我司业务员。

Note: if you need system parameters such as pump, pressure and motor power with different flow, please contact our salesman.

## 升降平台动力单元A

### LIFTING PLATFORM POWER UNIT A

此液压动力单元专为液压升降平台设计，由高压齿轮泵、交流电机、中心阀块、插装阀、油箱集成为一体，启动电机，实现平台上升，下降打开电磁阀依靠自重下降，内置压力补偿阀，可实现空载与负载匀速下降。有0.35-4KW可选电机，电压220-380V可选，有铁制和塑料油箱可供选择。

The hydraulic power unit is specially designed for the hydraulic lifting platform and is integrated by high-pressure gear pump, AC motor, central valve block, cartridge valve and oil tank. Start the motor to realize the rise and fall of the platform. Open the solenoid valve to fall by self weight. The built-in pressure compensation valve can realize the uniform drop of no-load and load. There are 0.35-4kw optional motors, 220-380v optional voltages, and iron and plastic oil tanks to choose from.



### 原理图/SCHEMATIC DIAGRAM

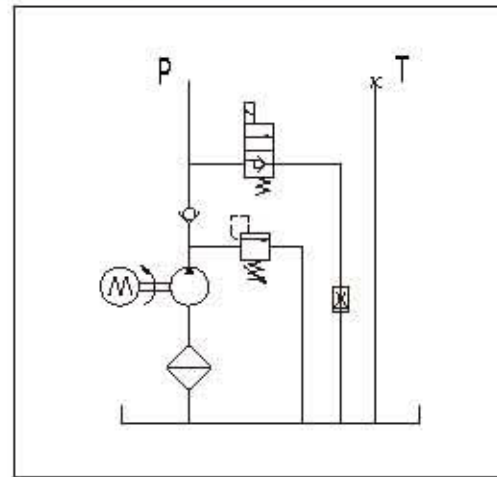

Y2

### 注意事项/SPECIAL NOTES

- 此动力单元为S3工作制，不可连续运转，10秒开，90秒停。
- 安装前必须保证油缸、油管、接头等液压元件无杂质黏附。
- 液压油粘度应为15-68ST，夏季推荐46号抗磨液压油，冬季推荐32号低温液压油。
- 首次启动运行系统后，应立即检查油箱中的油量是否充足，一般为油箱2/3部位。
- 系统使用第一个100小时后，应更换液压油，以后每3000小时更换一次液压油。

- The power unit is S3 working system and can not operate continuously. It starts in 10 seconds and stops in 90 seconds.
- Before installation, ensure that hydraulic components such as oil cylinder, oil pipe and joint are free of impurities.
- The viscosity of hydraulic oil shall be 15-68st. No. 46 anti-wear hydraulic oil is recommended in summer and No. 32 low temperature hydraulic oil is recommended in winter.
- After starting the operating system for the first time, check whether the oil in the oil tank is sufficient, generally 2 / 3 of the oil tank.
- After the system is used for the first 100 hours, the hydraulic oil shall be replaced, and then the hydraulic oil shall be replaced every 3000 hours.

### 产品配套/SPECIFICATIONS

型号 Model	电压 Volt	功率 Power	转速 Speed	油泵排量 Displacemet	工作压力 Pressure	油箱 Tank	电磁阀电压 Solenoid Vavle Volt
PNC-1.1-A380-1/2.1-18-3/W-Y2-4	380VAC	1.1KW	2800RPM	2.1CC/REV	15MPA	3L	24V
PNC-1.1/S-A220-1/2.1-18-3/W-Y2-4	220VAC		1400RPM				

说明：如需不同流量、压力、电机功率等系统参数，请联系我司业务员。

Note: if you need system parameters such as pump, pressure and motor power with different flow, please contact our salesman.

## 升降平台动力单元B

### LIFTING PLATFORM POWER UNIT B

此液压动力单元专为液压升降平台设计，由高压齿轮泵、交流电机、中心阀块、插装阀、油箱集成为一体，启动电机，实现平台上升，下降打开电磁阀依靠自重下降，内置压力补偿阀，可实现空载与负载匀速下降。有0.35-4KW可选电机，电压220-380V可选，有铁制和塑料油箱可供选择。

The hydraulic power unit is specially designed for the hydraulic lifting platform and is integrated by high-pressure gear pump, AC motor, central valve block, cartridge valve and oil tank. Start the motor to realize the rise and fall of the platform. Open the solenoid valve to fall by self weight. The built-in pressure compensation valve can realize the uniform drop of no-load and load. There are 0.35-4kw optional motors, 220-380v optional voltages, and iron and plastic oil tanks to choose from.



### 原理图/SCHEMATIC DIAGRAM

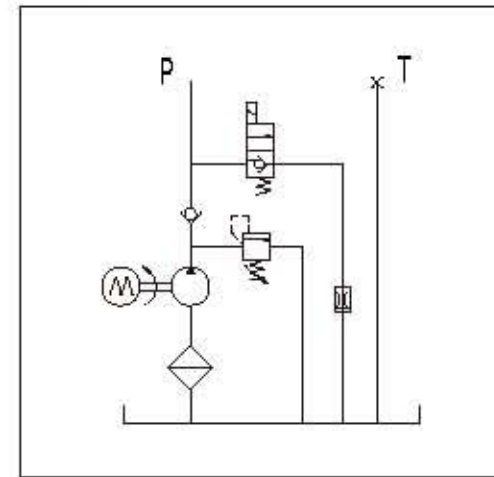

Y2

### 注意事项/SPECIAL NOTES

- 此动力单元为S3工作制，不可连续运转，10秒开，90秒停。
- 安装前必须保证油缸、油管、接头等液压元件无杂质黏附。
- 液压油粘度应为15-68ST，夏季推荐46号抗磨液压油，冬季推荐32号低温液压油。
- 首次启动运行系统后，应立即检查油箱中的油量是否充足，一般为油箱2/3部位。
- 系统使用第一个100小时后，应更换液压油，以后每3000小时更换一次液压油。

- The power unit is S3 working system and can not operate continuously. It starts in 10 seconds and stops in 90 seconds.
- Before installation, ensure that hydraulic components such as oil cylinder, oil pipe and joint are free of impurities.
- The viscosity of hydraulic oil shall be 15-68st. No. 46 anti-wear hydraulic oil is recommended in summer and No. 32 low temperature hydraulic oil is recommended in winter.
- After starting the operating system for the first time, check whether the oil in the oil tank is sufficient, generally 2 / 3 of the oil tank.
- After the system is used for the first 100 hours, the hydraulic oil shall be replaced, and then the hydraulic oil shall be replaced every 3000 hours.

### 产品配套/SPECIFICATIONS

型号 Model	电压 Volt	功率 Power	转速 Speed	油泵排量 Displacemet	工作压力 Pressure	油箱 Tank	电磁阀电压 Solenoid Vavle Volt
PNC-1.1-A380-1/2.1-18-3/W-Y2-4	380VAC	1.1KW	1400RPM	2.1CC/REV	20MPA	3L	24V
PNC-1.1/S-A220-1/2.1-18-3/W-Y2-4	220VAC						
PNC-1.5-A380-1/4.2-18-6/W-Y2-6	380VAC	1.5KW	1400RPM	4.2CC/REV	20MPA	6L	24V
PNC-2.2-A380-1/5.8-18-6/W-Y2-8		2.2KW					

说明：如需不同流量、压力、电机功率等系统参数，请联系我司业务员。

Note: if you need system parameters such as pump, pressure and motor power with different flow, please contact our salesman.

## 大剪举升机动力单元

### LARGE SHEAR LIFTING POWER UNIT

此液压动力单元专为大剪举升机设计，由高压齿轮泵、交流电机、中心阀块、插装阀、油箱集成于一体。采用零泄露双向止回电磁阀实现两条油路的完全隔离，使得两条油路间的动作互不干扰。电压220-380V可选，有铁制和塑料油箱可供选择。

This hydraulic power unit is specially designed for the large shear lift. It is integrated by high-pressure gear pump, AC motor, central valve block, cartridge valve and oil tank. The zero leakage two-way check solenoid valve is used to realize the complete isolation of the two oil circuits, so that the actions between the two oil circuits do not interfere with each other. The voltage is 220-380V, and there are iron and plastic oil tanks to choose from.



#### 原理图/SCHEMATIC DIAGRAM

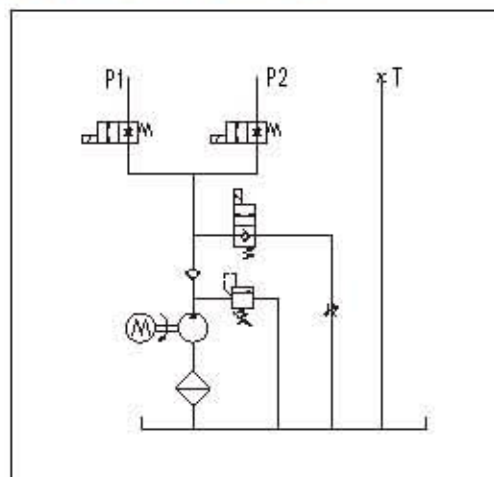

Y7

#### 注意事项/SPECIAL NOTES

- 此动力单元为S3工作制，不可连续运转，10秒开，90秒停。
  - 安装前必须保证油缸、油管、接头等液压元件无杂质黏附。
  - 液压油粘度应为15-68ST，夏季推荐46号抗磨液压油，冬季推荐32号低温液压油。
  - 首次启动运行系统后，应立即检查油箱中的油量是否充足，一般为油箱2/3部位。
  - 系统使用第一个100小时后，应更换液压油，以后每3000小时更换一次液压油。
- The power unit is S3 working system and can not operate continuously. It starts in 10 seconds and stops in 90 seconds.
  - Before installation, ensure that hydraulic components such as oil cylinder, oil pipe and joint are free of impurities.
  - The viscosity of hydraulic oil shall be 15-68st. No. 46 anti-wear hydraulic oil is recommended in summer and No. 32 low temperature hydraulic oil is recommended in winter.
  - After starting the operating system for the first time, check whether the oil in the oil tank is sufficient, generally 2 / 3 of the oil tank.
  - After the system is used for the first 100 hours, the hydraulic oil shall be replaced, and then the hydraulic oil shall be replaced every 3000 hours.

#### 产品配置/SPECIFICATIONS

型号 Model	电压 Volt	功率 Power	转速 Speed	油泵排量 Displacemet	工作压力 Pressure	油箱 Tank	电磁阀电压 Solenoid Vavle Volt
PNC-2.2/S-A220-2P-1/2.1-25-15/L-Y7	220VAC	2.2KW	2800RPM	2.1CC/REV	25MPA	15L	24V
PNC-2.2-A380-4P-1/4.2-25-15/L-Y7	380VAC	4.2KW	2600RPM	4.2CC/REV			

说明：如需不同流量、压力、电机功率等系统参数，请联系我司业务员。

Note: if you need system parameters such as pump, pressure and motor power with different flow, please contact our salesman.

## 伸缩皮带机动力单元

### TELESCOPIC BELT POWER UNIT

此液压动力单元专为伸缩皮带机设计，由高压齿轮泵、交流电机、中心阀块、插装阀、油箱集成于一体。启动电机，实现设备上升，下降打开电磁阀依靠自重下降，内置压力补偿阀，可实现空载与负载匀速下降。有1.5-4KW可选电机，电压220-380V可选，有铁制和塑料油箱可供选择。

This hydraulic power unit is specially designed for the telescopic belt conveyor and is integrated by high-pressure gear pump, AC motor, central valve block, cartridge valve and oil tank. Start the motor to realize the rise and fall of the equipment. Open the solenoid valve to fall by self weight. The built-in pressure compensation valve can realize the uniform drop of no-load and load. There are 1.5-4kw optional motors, 220-380V optional voltages, and iron and plastic oil tanks to choose from.



#### 原理图/SCHEMATIC DIAGRAM

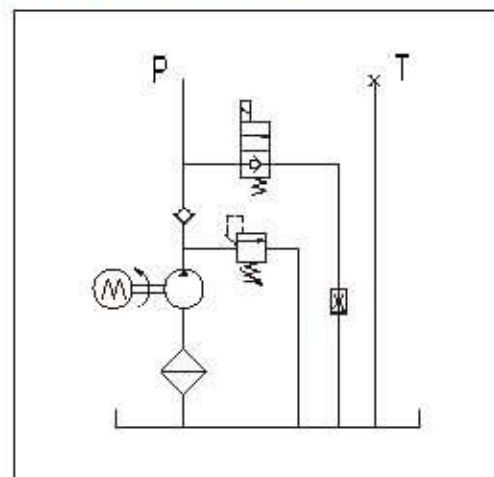

Y2

#### 注意事项/SPECIAL NOTES

- 此动力单元为S3工作制，不可连续运转，10秒开，90秒停。
  - 安装前必须保证油缸、油管、接头等液压元件无杂质黏附。
  - 液压油粘度应为15-68ST，夏季推荐46号抗磨液压油，冬季推荐32号低温液压油。
  - 首次启动运行系统后，应立即检查油箱中的油量是否充足，一般为油箱2/3部位。
  - 系统使用第一个100小时后，应更换液压油，以后每3000小时更换一次液压油。
- The power unit is S3 working system and can not operate continuously. It starts in 10 seconds and stops in 90 seconds.
  - Before installation, ensure that hydraulic components such as oil cylinder, oil pipe and joint are free of impurities.
  - The viscosity of hydraulic oil shall be 15-68st. No. 46 anti-wear hydraulic oil is recommended in summer and No. 32 low temperature hydraulic oil is recommended in winter.
  - After starting the operating system for the first time, check whether the oil in the oil tank is sufficient, generally 2 / 3 of the oil tank.
  - After the system is used for the first 100 hours, the hydraulic oil shall be replaced, and then the hydraulic oil shall be replaced every 3000 hours.

#### 产品配置/SPECIFICATIONS

型号 Model	电压 Volt	功率 Power	转速 Speed	油泵排量 Displacemet	工作压力 Pressure	油箱 Tank	电磁阀电压 Solenoid Vavle Volt
PNC-1.5-A380-4P-1/3.2-20-6/L-Y2	380VAC	1.5KW	1400RPM	3.2CC/REV	20MPA	6L	24V
PNC-2.2-A380-4P-1/2.7-20-8/L-Y2		2.2KW		4.2CC/REV		8L	

说明：如需不同流量、压力、电机功率等系统参数，请联系我司业务员。

Note: if you need system parameters such as pump, pressure and motor power with different flow, please contact our salesman.

## 机床液压夹紧动力单元

### HYDRAULIC CLAMPING POWER UNIT OF MACHINE TOOL

此液压动力单元专为机床夹紧缸设计，由高压齿轮泵、交流电机、中心阀块、插装阀、油箱集成为一体。采用液压锁保压系统，可选配蓄能器，压力开关等相结合的自动补压装置，由于体积小，电机间歇启动，更加节能。有0.75-1.5KW可选电机，电压220-380V可选，有铁制和塑料油箱可供选择。

This hydraulic power unit is specially designed for the clamping cylinder of machine tool. It is integrated by high-pressure gear pump, AC motor, central valve block, cartridge valve and oil tank. The hydraulic lock and pressure maintaining system is adopted, and the automatic pressure supplement device combined with accumulator and pressure switch can be selected. Due to its small volume, the motor starts intermittently, which is more energy-saving. There are 0.75-1.5kw optional motors, 220-380v optional voltages, and iron and plastic oil tanks to choose from.



### 原理图/SCHEMATIC DIAGRAM

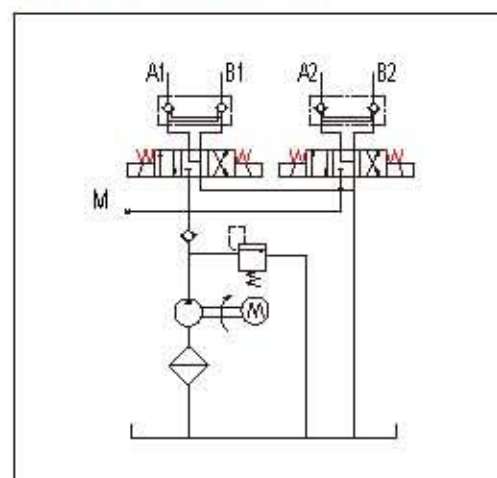

Y19

### 注意事项/SPECIAL NOTES

- 此动力单元为S3工作制，不可连续运转，10秒开，90秒停。
- 安装前必须保证油缸、油管、接头等液压元件无杂质黏附。
- 液压油粘度应为15-68ST，夏季推荐46号抗磨液压油，冬季推荐32号低温液压油。
- 首次启动运行系统后，应立即检查油箱中的油量是否充足，一般为油箱2/3部位。
- 系统使用第一个100小时后，应更换液压油，以后每3000小时更换一次液压油。
- The power unit is S3 working system and can not operate continuously. It starts in 10 seconds and stops in 90 seconds.
- Before installation, ensure that hydraulic components such as oil cylinder, oil pipe and joint are free of impurities.
- The viscosity of hydraulic oil shall be 15-68st. No. 46 anti-wear hydraulic oil is recommended in summer and No. 32 low temperature hydraulic oil is recommended in winter.
- After starting the operating system for the first time, check whether the oil in the oil tank is sufficient, generally 2 / 3 of the oil tank.
- After the system is used for the first 100 hours, the hydraulic oil shall be replaced, and then the hydraulic oil shall be replaced every 3000 hours.

### 产品配置/SPECIFICATIONS

型号 Model	电压 Volt	功率 Power	转速 Speed	油泵排量 Displacemet	工作压力 Pressure	油箱 Tank	电磁阀电压 Solenoid Valve Volt
PNC-0.75-A380-4P-1/3.2-7-6/W-Y19	380VAC	0.75KW	1400RPM	3.2CC/REV	7MPA	6L	24V
PNC-1.5-A380-4P-1/7.0-7-6/W-Y19		1.5KW		7.0CC/REV			

说明：如需不同流量、压力、电机功率等系统参数，请联系我司业务员。

Note: if you need system parameters such as pump, pressure and motor power with different flow, please contact our salesman.

## 热熔对接焊机动力单元

### WELDING MACHINE POWER UNIT

此液压动力单元专为热熔对接焊机设计，由高压齿轮泵、交流电机、中心阀块、插装阀、油箱集成为一体。采用插装式液压锁加蓄能器相结合的自动保压装置，保压效果好。由于体积小，电机间歇启动，更加节能。有0.75-3KW可选电机，电压220-380V可选，有铁制和塑料油箱可供选择。

This hydraulic power unit is specially designed for hot-melt butt welding machine and is integrated by high-pressure gear pump, AC motor, central valve block, cartridge valve and oil tank. The automatic pressure maintaining device combined with plug-in hydraulic lock and accumulator has good pressure maintaining effect. Due to its small size, the motor starts intermittently, which is more energy-saving. There are 0.75-3kw optional motors, 220-380v optional voltages, and iron and plastic oil tanks to choose from.



### 原理图/SCHEMATIC DIAGRAM

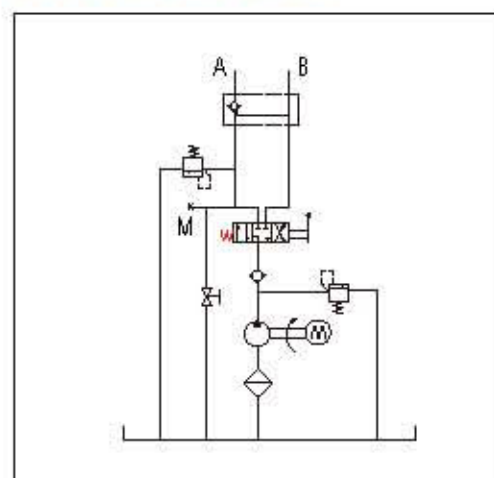

Y20

### 注意事项/SPECIAL NOTES

- 此动力单元为S3工作制，不可连续运转，10秒开，90秒停。
- 安装前必须保证油缸、油管、接头等液压元件无杂质黏附。
- 液压油粘度应为15-68ST，夏季推荐46号抗磨液压油，冬季推荐32号低温液压油。
- 首次启动运行系统后，应立即检查油箱中的油量是否充足，一般为油箱2/3部位。
- 系统使用第一个100小时后，应更换液压油，以后每3000小时更换一次液压油。
- The power unit is S3 working system and can not operate continuously. It starts in 10 seconds and stops in 90 seconds.
- Before installation, ensure that hydraulic components such as oil cylinder, oil pipe and joint are free of impurities.
- The viscosity of hydraulic oil shall be 15-68st. No. 46 anti-wear hydraulic oil is recommended in summer and No. 32 low temperature hydraulic oil is recommended in winter.
- After starting the operating system for the first time, check whether the oil in the oil tank is sufficient, generally 2 / 3 of the oil tank.
- After the system is used for the first 100 hours, the hydraulic oil shall be replaced, and then the hydraulic oil shall be replaced every 3000 hours.

### 产品配置/SPECIFICATIONS

型号 Model	电压 Volt	功率 Power	转速 Speed	油泵排量 Displacemet	工作压力 Pressure	油箱 Tank	电磁阀电压 Solenoid Valve Volt
PNC-0.75/S-A220-4P-1/1.6-10-3/W-Y20	220VAC	0.75KW	1400RPM	1.6CC/REV	10MPA	3L	220VDC
PNC-1.5-A380-4P-1/5.0-10-5/W-Y20	380VAC	1.5KW		5.0CC/REV		5L	
PNC-2.2-A380-4P-1/6.0-10-5/W-Y20		2.2KW	2600RPM	6.0CC/REV			

说明：如需不同流量、压力、电机功率等系统参数，请联系我司业务员。

Note: if you need system parameters such as pump, pressure and motor power with different flow, please contact our salesman.

## 管材切割机动力单元

### PIPE CUTTING POWER UNIT

此液压力单元专为管材切割机的旋转进刀设计，由高压齿轮泵、交流电机、中心阀块、插装阀、油箱集成为一体。采用意大利进口的节流阀，可实现在高温热压油的情况下慢速稳定进刀，快速退刀，由于在使用过程中需要360°旋转，因此设计了加厚法兰油箱。电机0.55KW，电压220-380V可选。

This hydraulic power unit is specially designed for the rotary feed of pipe cutting machine. It is integrated by high-pressure gear pump, AC motor, central valve block, cartridge valve and oil tank. The throttle valve imported from Italy can realize slow and stable feed and rapid withdrawal of the tool under the condition of high-temperature hot pressing oil. Because it needs 360° rotation in the process of use, a thickened flange oil tank is designed. Motor 0.55kw, voltage 220-380v optional.



### 原理图/SCHEMATIC DIAGRAM

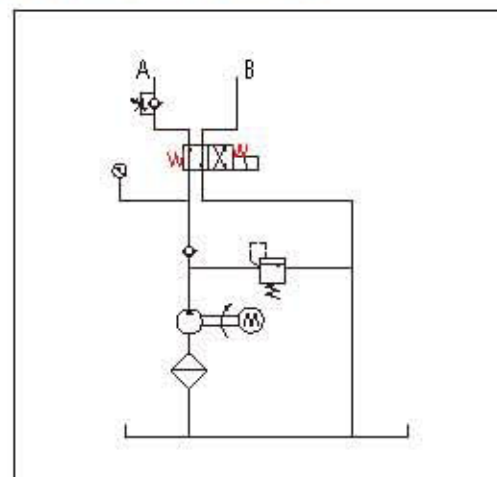

Y21

### 注意事项/SPECIAL NOTES

- 此动力单元为S3工作制，不可连续运转，10秒开，90秒停。
- 安装前必须保证油缸、油管、接头等液压元件无杂质黏附。
- 液压油粘度应为15-68ST，夏季推荐46号抗磨液压油，冬季推荐32号低温液压油。
- 首次启动运行系统后，应立即检查油箱中的油量是否充足，一般为油箱2/3部位。
- 系统使用第一个100小时后，应更换液压油，以后每3000小时更换一次液压油。

- The power unit is S3 working system and can not operate continuously. It starts in 10 seconds and stops in 90 seconds.
- Before installation, ensure that hydraulic components such as oil cylinder, oil pipe and joint are free of impurities.
- The viscosity of hydraulic oil shall be 15-68st. No. 46 anti-wear hydraulic oil is recommended in summer and No. 32 low temperature hydraulic oil is recommended in winter.
- After starting the operating system for the first time, check whether the oil in the oil tank is sufficient, generally 2 / 3 of the oil tank.
- After the system is used for the first 100 hours, the hydraulic oil shall be replaced, and then the hydraulic oil shall be replaced every 3000 hours.

### 产品配置/SPECIFICATIONS

型号 Model	电压 Volt	功率 Power	转速 Speed	油泵排量 Displacemet	工作压力 Pressure	油箱 Tank	电磁阀电压 Solenoid Vavle Volt
PNC-0.55-A380-4P-1/3.2-4-5/L-Y21	380VAC	0.55KW	1400RPM	3.2CC/REV	4MPA	5L	220V

说明：如需不同流量、压力、电机功率等系统参数，请联系我司业务员。

Note: if you need system parameters such as pump, pressure and motor power with different flow, please contact our salesman.

## 拦蓄冲洗门动力单元

### POWER UNIT OF STORAGE FLUSHING DOOR

此液压力单元专为拦蓄冲洗门设计，由高压齿轮泵、交流电机、中心阀块、插装阀、油箱集成为一体。采用模块化的设计，可叠加2-10路意大利进口双止回电磁阀，零泄露，保压好，可实现多个冲洗门的单独控制。选用0.55-1.1KW电机，可选铁制和塑料油箱。

This hydraulic power unit is specially designed for the storage flushing door and is integrated by high-pressure gear pump, AC motor, central valve block, cartridge valve and oil tank. The modular design is adopted, and 2-10 channels of Italian imported double check solenoid valves can be superimposed, with zero leakage and good pressure holding, which can realize the independent control of multiple flushing doors. Select 0.55-1.1kw motor and iron and plastic oil tank.



### 原理图/SCHEMATIC DIAGRAM

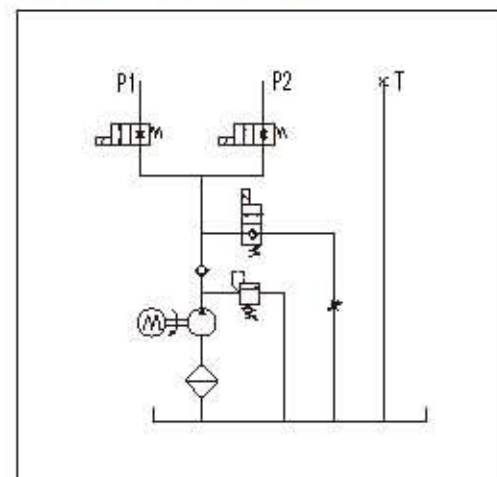

Y7

### 注意事项/SPECIAL NOTES

- 此动力单元为S3工作制，不可连续运转，10秒开，90秒停。
- 安装前必须保证油缸、油管、接头等液压元件无杂质黏附。
- 液压油粘度应为15-68ST，夏季推荐46号抗磨液压油，冬季推荐32号低温液压油。
- 首次启动运行系统后，应立即检查油箱中的油量是否充足，一般为油箱2/3部位。
- 系统使用第一个100小时后，应更换液压油，以后每3000小时更换一次液压油。

- The power unit is S3 working system and can not operate continuously. It starts in 10 seconds and stops in 90 seconds.
- Before installation, ensure that hydraulic components such as oil cylinder, oil pipe and joint are free of impurities.
- The viscosity of hydraulic oil shall be 15-68st. No. 46 anti-wear hydraulic oil is recommended in summer and No. 32 low temperature hydraulic oil is recommended in winter.
- After starting the operating system for the first time, check whether the oil in the oil tank is sufficient, generally 2 / 3 of the oil tank.
- After the system is used for the first 100 hours, the hydraulic oil shall be replaced, and then the hydraulic oil shall be replaced every 3000 hours.

### 产品配置/SPECIFICATIONS

型号 Model	电压 Volt	功率 Power	转速 Speed	油泵排量 Displacemet	工作压力 Pressure	油箱 Tank	电磁阀电压 Solenoid Vavle Volt
PNC-0.55-A380-4P-1/5.0-4-5/L-Y7	380VAC	0.55KW	1400RPM	5.0CC/REV	4MPA	5L	24V
PNC-1.1-A380-4P-1/7.0-10-5/L-Y7		1.1KW		7.0CC/REV			

说明：如需不同流量、压力、电机功率等系统参数，请联系我司业务员。

Note: if you need system parameters such as pump, pressure and motor power with different flow, please contact our salesman.

## 交流双作用动力单元

### AC DOUBLE ACTING POWER UNIT

此液压动力单元专为双作用油缸系统设计，由高压齿轮泵、交流电机、中心阀块、插装阀、油箱集成为一体。采用模块化的设计，可任意叠加双作用电磁阀，液压锁，节流阀等。选用0.55-5.5KW电机，可选铁制和塑料油箱。

This hydraulic power unit is specially designed for double acting oil cylinder system, which is integrated by high-pressure gear pump, AC motor, central valve block, cartridge valve and oil tank. Modular design is adopted, and double acting solenoid valve, hydraulic lock, throttle valve, etc. can be superimposed arbitrarily. Select 0.55-5.5kw motor and iron and plastic oil tank.



### 原理图/SCHEMATIC DIAGRAM

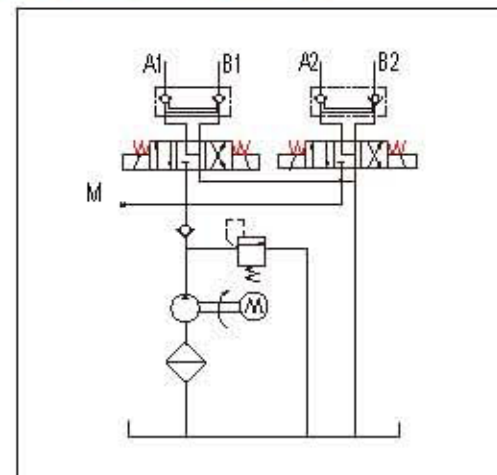

Y19

### 注意事项/SPECIAL NOTES

- 此动力单元为S3工作制，不可连续运转，10秒开，90秒停。
- 安装前必须保证油缸、油管、接头等液压元件无杂质黏附。
- 液压油粘度应为15-68ST，夏季推荐46号抗磨液压油，冬季推荐32号低温液压油。
- 首次启动运行系统后，应立即检查油箱中的油量是否充足，一般为油箱2/3部位。
- 系统使用第一个100小时后，应更换液压油，以后每3000小时更换一次液压油。
- The power unit is S3 working system and can not operate continuously. It starts in 10 seconds and stops in 90 seconds.
- Before installation, ensure that hydraulic components such as oil cylinder, oil pipe and joint are free of impurities.
- The viscosity of hydraulic oil shall be 15-68st. No. 46 anti-wear hydraulic oil is recommended in summer and No. 32 low temperature hydraulic oil is recommended in winter.
- After starting the operating system for the first time, check whether the oil in the oil tank is sufficient, generally 2 / 3 of the oil tank.
- After the system is used for the first 100 hours, the hydraulic oil shall be replaced, and then the hydraulic oil shall be replaced every 3000 hours.

### 产品配套/SPECIFICATIONS

型号 Model	电压 Volt	功率 Power	转速 Speed	油泵排量 Displacemet	工作压力 Pressure	油箱 Tank	电磁阀电压 Solenoid Vavle Volt
PNC-0.55-A380-4P-1/1.2-4-16/L-Y19	380VAC	0.55KW	1400RPM	1.2CC/REV	16MPA	15L	220V
PNC-1.5-A380-4P-1/5.0-4-16/L-Y19		1.5KW		5.0CC/REV		22L	24V
PNC-3-A380-4P-1/7.0-10-16/L-Y19		3KW		7.0CC/REV		40L	

说明：如需不同流量、压力、电机功率等系统参数，请联系我司业务员。

Note: if you need system parameters such as pump, pressure and motor power with different flow, please contact our salesman.

## 一体升降柱动力单元

### INTEGRATED LIFTING COLUMN POWER UNIT

此液压动力单元专为一体式液压升降柱所设计，由双向齿轮泵、交流浸油电机、阀块、插装阀、油箱集成为一体。采用双向泵的设计结构，上升和下降依靠电机正反转实现，避免了使用电磁阀换向，结构紧凑。防水等级IP68，可以泡水使用。电机0.35KW，电压220-380V可选。

The hydraulic power unit is specially designed for the integrated hydraulic lifting column, which is integrated by two-way gear pump, AC oil immersion motor, valve block, cartridge valve and oil tank. The design structure of the two-way pump is adopted, and the rise and fall are realized by the forward and reverse rotation of the motor, which avoids the commutation of the solenoid valve, and the structure is compact. The waterproof grade is IP68 and can be used in water. Motor 0.35kw, voltage 220-380v optional.



### 原理图/SCHEMATIC DIAGRAM

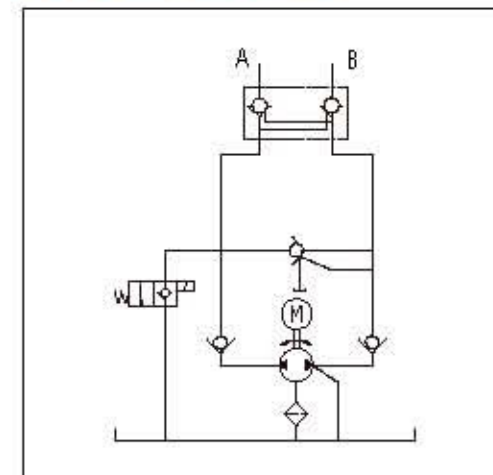

Y23

### 注意事项/SPECIAL NOTES

- 此动力单元为S3工作制，不可连续运转，10秒开，90秒停。
- 安装前必须保证油缸、油管、接头等液压元件无杂质黏附。
- 液压油粘度应为15-68ST，夏季推荐46号抗磨液压油，冬季推荐32号低温液压油。
- 首次启动运行系统后，应立即检查油箱中的油量是否充足，一般为油箱2/3部位。
- 系统使用第一个100小时后，应更换液压油，以后每3000小时更换一次液压油。
- The power unit is S3 working system and can not operate continuously. It starts in 10 seconds and stops in 90 seconds.
- Before installation, ensure that hydraulic components such as oil cylinder, oil pipe and joint are free of impurities.
- The viscosity of hydraulic oil shall be 15-68st. No. 46 anti-wear hydraulic oil is recommended in summer and No. 32 low temperature hydraulic oil is recommended in winter.
- After starting the operating system for the first time, check whether the oil in the oil tank is sufficient, generally 2 / 3 of the oil tank.
- After the system is used for the first 100 hours, the hydraulic oil shall be replaced, and then the hydraulic oil shall be replaced every 3000 hours.

### 产品配套/SPECIFICATIONS

型号 Model	电压 Volt	功率 Power	转速 Speed	油泵排量 Displacemet	工作压力 Pressure	油箱 Tank	电磁阀电压 Solenoid Vavle Volt
PNC-0.35KW-A220-3S-JY-YT	220VAC	0.35KW	2800RPM	1.5CC/REV	6MPA	2L	12V
PNC-0.35KW-A220-4S-JY-YT				1.75CC/REV			
PNC-0.35KW-A380-4S-JY-YT	380VAC						

说明：如需不同流量、压力、电机功率等系统参数，请联系我司业务员。

Note: if you need system parameters such as pump, pressure and motor power with different flow, please contact our salesman.

## 一体多级缸升降柱动力单元

### INTEGRATED MULTISTAGE CYLINDER LIFTING COLUMN POWER UNIT

此液压动力单元专为一体浅埋式液压升降柱所设计，由双向齿轮泵、交流浸油电机、阀块、插装阀、油箱集成为一体。采用双向泵的设计结构，上升和下降依靠电机正反转实现，避免了使用电磁阀换向，结构紧凑。防水等级IP68，可以泡水使用。采用多级缸的设计，可以让安装高度更矮，适应于无法深挖施工的场所。电机0.35KW，电压220-380V可选。

The hydraulic power unit is specially designed for the integrated shallow buried hydraulic lifting column, which is integrated by two-way gear pump, AC oil immersion motor, valve block, cartridge valve and oil tank. The design structure of the two-way pump is adopted, and the rise and fall are realized by the forward and reverse rotation of the motor, which avoids the commutation of the solenoid valve, and the structure is compact. The waterproof grade is IP68 and can be used in water. The design of multi-stage cylinder can make the installation height shorter, which is suitable for occasions where deep excavation construction is impossible. Motor 0.35kw, voltage 220-380v optional.



### 原理图/SCHEMATIC DIAGRAM

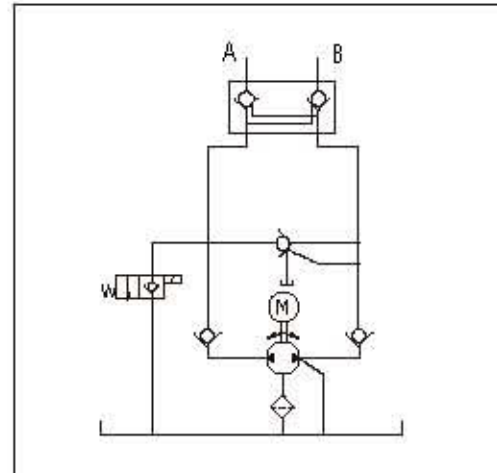

Y23

### 注意事项/SPECIAL NOTES

- 此动力单元为S3工作制，不可连续运转，10秒开，90秒停。
- 安装前必须保证油缸、油管、接头等液压元件无杂质黏附。
- 液压油粘度应为15-68ST，夏季推荐46号抗磨液压油，冬季推荐32号低温液压油。
- 首次启动运行系统后，应立即检查油箱中的油量是否充足，一般为油箱2/3部位。
- 系统使用第一个100小时后，应更换液压油，以后每3000小时更换一次液压油。
- The power unit is S3 working system and can not operate continuously. It starts in 10 seconds and stops in 90 seconds.
- Before installation, ensure that hydraulic components such as oil cylinder, oil pipe and joint are free of impurities.
- The viscosity of hydraulic oil shall be 15-68st. No. 46 anti-wear hydraulic oil is recommended in summer and No. 32 low temperature hydraulic oil is recommended in winter.
- After starting the operating system for the first time, check whether the oil in the oil tank is sufficient, generally 2 / 3 of the oil tank.
- After the system is used for the first 100 hours, the hydraulic oil shall be replaced, and then the hydraulic oil shall be replaced every 3000 hours.

### 产品配置/SPECIFICATIONS

型号 Model	电压 Volt	功率 Power	转速 Speed	油泵排量 Displacemet	工作压力 Pressure	油箱 Tank	电磁阀电压 Solenoid Vavle Volt
PNC-0.35KW-A220-LJ-JY-YT	220VDC	0.35KW	2800RPM	1.75CC/REV	6MPA	2L	12V
PNC-0.35KW-A380-LJ-JY-YT	380VDC						

说明：如需不同流量、压力、电机功率等系统参数，请联系我司业务员。

Note: if you need system parameters such as pump, pressure and motor power with different flow, please contact our salesman.

## 分体升降柱动力单元

### SPLIT LIFTING COLUMN POWER UNIT

此液压动力单元专为分体式液压升降柱所设计，由双向齿轮泵、交流浸油电机、阀块、插装阀、油箱集成为一体。采用双向泵的设计结构，上升和下降依靠电机正反转实现，避免了使用电磁阀换向，结构紧凑。防水等级IP68，可以泡水使用。采用分体设计，可以让安装高度更矮，适应于无法深挖施工的场所。电机0.35KW，电压220-380V可选。

This hydraulic power unit is specially designed for split hydraulic lifting column, which is integrated by two-way gear pump, AC oil immersion motor, valve block, cartridge valve and oil tank. The design structure of the two-way pump is adopted, and the rise and fall are realized by the forward and reverse rotation of the motor, which avoids the commutation of the solenoid valve, and the structure is compact. The waterproof grade is IP68 and can be used in water. The split design can make the installation height shorter, which is suitable for occasions where deep excavation construction is impossible. Motor 0.35kw, voltage 220-380v optional.

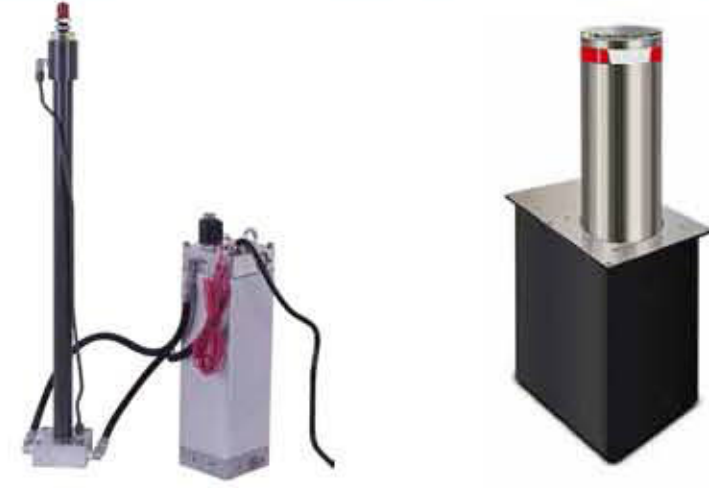

### 原理图/SCHEMATIC DIAGRAM

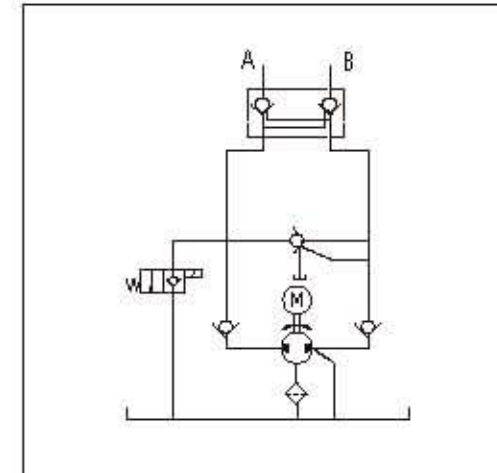

Y23

### 注意事项/SPECIAL NOTES

- 此动力单元为S3工作制，不可连续运转，10秒开，90秒停。
- 安装前必须保证油缸、油管、接头等液压元件无杂质黏附。
- 液压油粘度应为15-68ST，夏季推荐46号抗磨液压油，冬季推荐32号低温液压油。
- 首次启动运行系统后，应立即检查油箱中的油量是否充足，一般为油箱2/3部位。
- 系统使用第一个100小时后，应更换液压油，以后每3000小时更换一次液压油。
- The power unit is S3 working system and can not operate continuously. It starts in 10 seconds and stops in 90 seconds.
- Before installation, ensure that hydraulic components such as oil cylinder, oil pipe and joint are free of impurities.
- The viscosity of hydraulic oil shall be 15-68st. No. 46 anti-wear hydraulic oil is recommended in summer and No. 32 low temperature hydraulic oil is recommended in winter.
- After starting the operating system for the first time, check whether the oil in the oil tank is sufficient, generally 2 / 3 of the oil tank.
- After the system is used for the first 100 hours, the hydraulic oil shall be replaced, and then the hydraulic oil shall be replaced every 3000 hours.

### 产品配置/SPECIFICATIONS

型号 Model	电压 Volt	功率 Power	转速 Speed	油泵排量 Displacemet	工作压力 Pressure	油箱 Tank	电磁阀电压 Solenoid Vavle Volt
PNC-0.35KW-A220-3S-JY-FT	220VAC	0.35KW	2800RPM	1.5CC/REV	6MPA	2L	12V
PNC-0.35KW-A220-4S-JY-FT				1.75CC/REV			
PNC-0.35KW-A380-4S-JY-FT				380VAC			

说明：如需不同流量、压力、电机功率等系统参数，请联系我司业务员。

Note: if you need system parameters such as pump, pressure and motor power with different flow, please contact our salesman.

## 分体多级缸升降柱动力单元

### SPLIT MULTISTAGE CYLINDER LIFTING COLUMN POWER UNIT

此液压动力单元专为分体浅埋式液压升降柱所设计，由双向齿轮泵、交流浸油电机、阀块、插装阀、油箱集成为一体。采用双向泵的设计结构，上升和下降依靠电机正反转实现，避免了使用电磁阀换向，结构紧凑。防水等级IP68，可以泡水使用。采用分体多级缸的设计，使得升降柱总高度在500mm以内，适用于无法深挖施工的场所。电机0.35KW，电压220-380V可选。

This hydraulic power unit is specially designed for split shallow buried hydraulic lifting column, which is integrated by two-way gear pump, AC oil immersion motor, valve block, cartridge valve and oil tank. The design structure of the two-way pump is adopted, and the rise and fall are realized by the forward and reverse rotation of the motor, which avoids the commutation of the solenoid valve, and the structure is compact. The waterproof grade is IP68 and can be used in water. The design of split multi-stage cylinder is adopted, so that the total height of the lifting column is less than 500mm, which is suitable for occasions where deep excavation construction is impossible. Motor 0.35kw, voltage 220-380v optional.



### 原理图/SCHEMATIC DIAGRAM

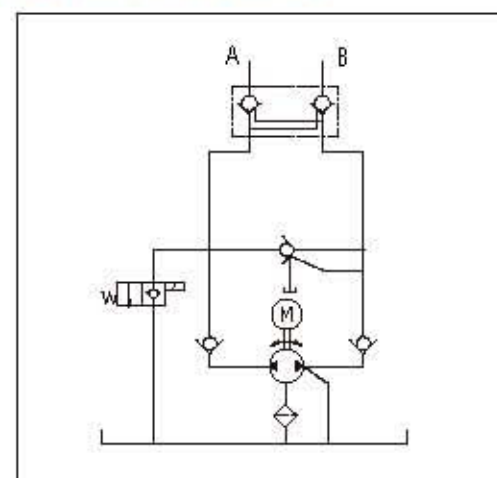

Y23

### 注意事项/SPECIAL NOTES

- 此动力单元为S3工作制，不可连续运转，10秒开，90秒停。
- 安装前必须保证油缸、油管、接头等液压元件无杂质黏附。
- 液压油粘度应为15-68ST，夏季推荐46号抗磨液压油，冬季推荐32号低温液压油。
- 首次启动运行系统后，应立即检查油箱中的油量是否充足，一般为油箱2/3部位。
- 系统使用第一个100小时后，应更换液压油，以后每3000小时更换一次液压油。
- The power unit is S3 working system and can not operate continuously. It starts in 10 seconds and stops in 90 seconds.
- Before installation, ensure that hydraulic components such as oil cylinder, oil pipe and joint are free of impurities.
- The viscosity of hydraulic oil shall be 15-68st. No. 46 anti-wear hydraulic oil is recommended in summer and No. 32 low temperature hydraulic oil is recommended in winter.
- After starting the operating system for the first time, check whether the oil in the oil tank is sufficient, generally 2 / 3 of the oil tank.
- After the system is used for the first 100 hours, the hydraulic oil shall be replaced, and then the hydraulic oil shall be replaced every 3000 hours.

### 产品配置/SPECIFICATIONS

型号 Model	电压 Volt	功率 Power	转速 Speed	油泵排量 Displacemet	工作压力 Pressure	油箱 Tank	电磁阀电压 Solenoid Vavle Volt
PNC-0.35KW-A220-LJ-JY-FT	220VDC	0.35KW	2800RPM	1.75CC/REV	6MPA	2L	12V
PNC-0.35KW-A380-LJ-JY-FT	380VDC						

说明：如需不同流量、压力、电机功率等系统参数，请联系我司业务员。

Note: if you need system parameters such as pump, pressure and motor power with different flow, please contact our salesman.

## 反恐路障机动力单元

### ANTI TERRORISM ROADBLOCK POWER UNIT

此液压动力单元专为反恐液压路障机所设计，由高压齿轮泵、交流浸油电机、阀块、插装阀、油箱集成为一体。采用油浸式电机的设计结构，防水IP68等级。上升和下降依靠电机和电磁阀的工作实现。有停电应急泄压功能，组合蓄能器使用可做到一秒级快速上升。电机1.5-3KW，电压220-380V可选。

This hydraulic power unit is specially designed for anti-terrorism hydraulic roadblock machine. It is integrated by high-pressure gear pump, AC oil immersion motor, valve block, cartridge valve and oil tank. The design structure of oil immersed motor is adopted, and the waterproof grade is IP68. The rising and falling are realized by the operation of motor and solenoid valve. It has power failure emergency pressure relief function, and the use of combined accumulator can achieve rapid rise in one second. Motor 1.5-3kw, voltage 220-380v optional.



### 原理图/SCHEMATIC DIAGRAM

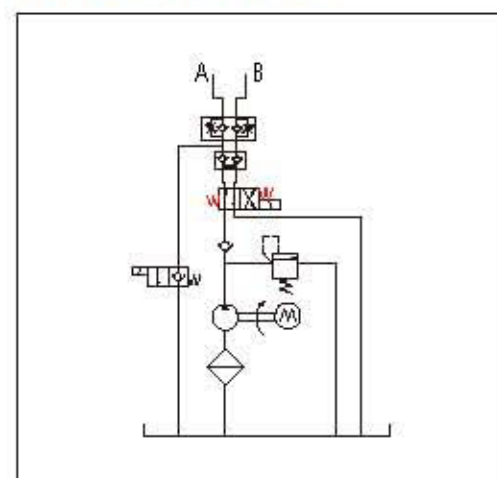

Y22

### 注意事项/SPECIAL NOTES

- 此动力单元为S3工作制，不可连续运转，10秒开，90秒停。
- 安装前必须保证油缸、油管、接头等液压元件无杂质黏附。
- 液压油粘度应为15-68ST，夏季推荐46号抗磨液压油，冬季推荐32号低温液压油。
- 首次启动运行系统后，应立即检查油箱中的油量是否充足，一般为油箱2/3部位。
- 系统使用第一个100小时后，应更换液压油，以后每3000小时更换一次液压油。
- The power unit is S3 working system and can not operate continuously. It starts in 10 seconds and stops in 90 seconds.
- Before installation, ensure that hydraulic components such as oil cylinder, oil pipe and joint are free of impurities.
- The viscosity of hydraulic oil shall be 15-68st. No. 46 anti-wear hydraulic oil is recommended in summer and No. 32 low temperature hydraulic oil is recommended in winter.
- After starting the operating system for the first time, check whether the oil in the oil tank is sufficient, generally 2 / 3 of the oil tank.
- After the system is used for the first 100 hours, the hydraulic oil shall be replaced, and then the hydraulic oil shall be replaced every 3000 hours.

### 产品配置/SPECIFICATIONS

型号 Model	电压 Volt	功率 Power	转速 Speed	油泵排量 Displacemet	工作压力 Pressure	油箱 Tank	电磁阀电压 Solenoid Vavle Volt
PNC-1.5/S-A220-4P-1/5.8-10-22/L-Y22	220VAC	1.5KW	1400RPM	5.8CC/REV	10MPA	22L	12V
PNC-1.5-A380-2P-1/3.2-12-10/L-Y22	380VAC						
PNC-3-A380-2P-1/5.8-14-22/L-Y22		3KW	5.8CC/REV	14MPA	22L		

说明：如需不同流量、压力、电机功率等系统参数，请联系我司业务员。

Note: if you need system parameters such as pump, pressure and motor power with different flow, please contact our salesman.

## 浸油式双向泵动力单元

### OIL IMMERSED BIDIRECTIONAL PUMP POWER UNIT

此液压力单元为由高压双向齿轮泵、交流浸油电机、阀块、插装阀、油箱集成为一体。采用油浸式电机的设计结构，防水IP68等级。油缸换向依靠电机正反转实现。由于噪音小，空间紧凑，被广泛应用于各类机械设备。电机0.1-0.35KW，电压220-380V可选。

The hydraulic power unit is a high-pressure bidirectional gear pump, AC oil immersion motor, valve block, cartridge valve and oil tank. The design structure of oil immersed motor is adopted, and the waterproof grade is IP68. The reversing of oil cylinder depends on the forward and reverse rotation of motor. Due to low noise and compact space, it is widely used in all kinds of mechanical equipment. Motor 0.1-0.35kw, voltage 220-380v optional.



### 原理图/SCHEMATIC DIAGRAM

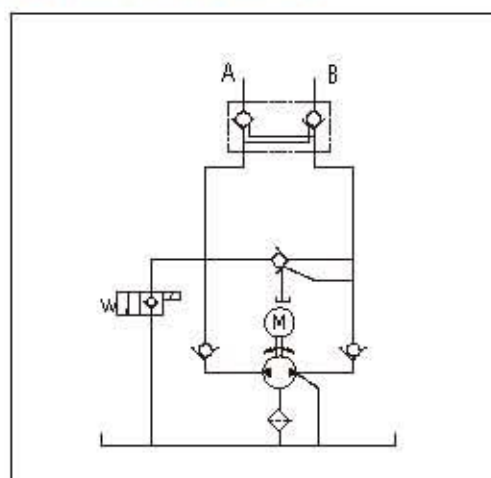

Y23

### 注意事项/SPECIAL NOTES

- 此动力单元为S3工作制，不可连续运转，10秒开，90秒停。
- 安装前必须保证油缸、油管、接头等液压元件无杂质黏附。
- 液压油粘度应为15-68ST，夏季推荐46号抗磨液压油，冬季推荐32号低温液压油。
- 首次启动运行系统后，应立即检查油箱中的油量是否充足，一般为油箱2/3部位。
- 系统使用第一个100小时后，应更换液压油，以后每3000小时更换一次液压油。
- The power unit is S3 working system and can not operate continuously. It starts in 10 seconds and stops in 90 seconds.
- Before installation, ensure that hydraulic components such as oil cylinder, oil pipe and joint are free of impurities.
- The viscosity of hydraulic oil shall be 15-68st. No. 46 anti-wear hydraulic oil is recommended in summer and No. 32 low temperature hydraulic oil is recommended in winter.
- After starting the operating system for the first time, check whether the oil in the oil tank is sufficient, generally 2 / 3 of the oil tank.
- After the system is used for the first 100 hours, the hydraulic oil shall be replaced, and then the hydraulic oil shall be replaced every 3000 hours.

### 产品配套/SPECIFICATIONS

型号 Model	电压 Volt	功率 Power	转速 Speed	油泵排量 Displacemet	工作压力 Pressure	油箱 Tank	电磁阀电压 Solenoid Vavle Volt
PNC-0.2/S-A220-4P-0.5/0.26-10-2/W-Y23	220VAC	0.2KW	1400RPM	0.26CC/REV	10MPA	2L	NULL
PNC-0.35/S-A220-2P-0.5/0.75-12-2/W-Y23		0.35KW	2800RPM	0.75CC/REV	12MPA		
PNC-0.35-A380-2P-0.5/1.0-14-2/W-Y23	380VAC			1.0CC/REV	14MPA		

说明：如需不同流量、压力、电机功率等系统参数，请联系我司业务员。

Note: if you need system parameters such as pump, pressure and motor power with different flow, please contact our salesman.

## 浸油式双作用动力单元

### OIL IMMERSED DOUBLE ACTING POWER UNIT

此液压力单元为由高压齿轮泵、交流浸油电机、阀块、插装阀、油箱集成为一体。采用油浸式电机的设计结构，防水IP68等级。油缸换向依靠电磁阀换向实现，可叠加多路液压锁，调速阀组合使用。由于噪音小，空间紧凑，被广泛应用于各类机械设备。电机0.1-0.35KW，电压220-380V可选。

The hydraulic power unit is composed of high-pressure gear pump, AC oil immersion motor, valve block, cartridge valve and oil tank. The design structure of oil immersed motor is adopted, and the waterproof grade is IP68. The reversing of oil cylinder depends on the reversing of solenoid valve, which can be combined with multi-channel hydraulic lock and speed regulating valve. Due to low noise and compact space, it is widely used in all kinds of mechanical equipment. Motor 0.1-0.35kw, voltage 220-380v optional.

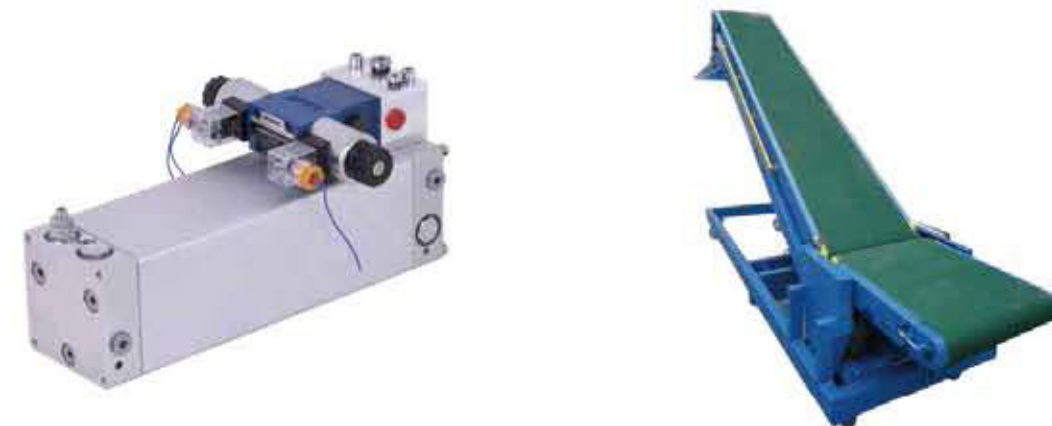

### 原理图/SCHEMATIC DIAGRAM

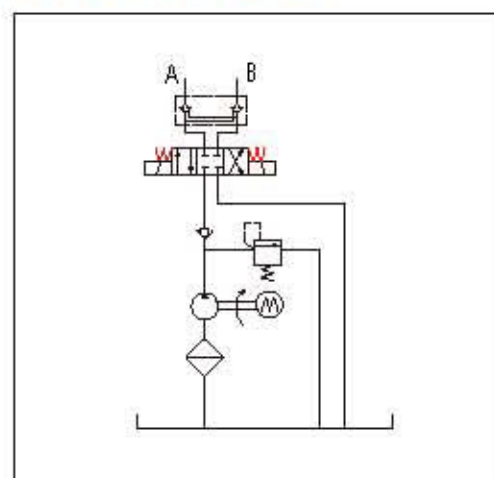

Y10

### 注意事项/SPECIAL NOTES

- 此动力单元为S3工作制，不可连续运转，10秒开，90秒停。
- 安装前必须保证油缸、油管、接头等液压元件无杂质黏附。
- 液压油粘度应为15-68ST，夏季推荐46号抗磨液压油，冬季推荐32号低温液压油。
- 首次启动运行系统后，应立即检查油箱中的油量是否充足，一般为油箱2/3部位。
- 系统使用第一个100小时后，应更换液压油，以后每3000小时更换一次液压油。
- The power unit is S3 working system and can not operate continuously. It starts in 10 seconds and stops in 90 seconds.
- Before installation, ensure that hydraulic components such as oil cylinder, oil pipe and joint are free of impurities.
- The viscosity of hydraulic oil shall be 15-68st. No. 46 anti-wear hydraulic oil is recommended in summer and No. 32 low temperature hydraulic oil is recommended in winter.
- After starting the operating system for the first time, check whether the oil in the oil tank is sufficient, generally 2 / 3 of the oil tank.
- After the system is used for the first 100 hours, the hydraulic oil shall be replaced, and then the hydraulic oil shall be replaced every 3000 hours.

### 产品配套/SPECIFICATIONS

型号 Model	电压 Volt	功率 Power	转速 Speed	油泵排量 Displacemet	工作压力 Pressure	油箱 Tank	电磁阀电压 Solenoid Vavle Volt
PNC-0.2/S-A220-4P-0.5/0.26-10-2/W-Y10	220VAC	0.2KW	1400RPM	0.26CC/REV	10MPA	2L	12/24V
PNC-0.35/S-A220-2P-0.5/0.75-12-2/W-Y10		0.35KW	2800RPM	0.75CC/REV	12MPA		
PNC-0.35-A380-2P-0.5/1.0-14-2/W-Y10	380VAC			1.0CC/REV	14MPA		

说明：如需不同流量、压力、电机功率等系统参数，请联系我司业务员。

Note: if you need system parameters such as pump, pressure and motor power with different flow, please contact our salesman.

## 液压货梯静音动力单元

### SILENT POWER UNIT OF HYDRAULIC CARGO ELEVATOR

此液压动力单元专为液压货梯设计，由高压叶片泵、交流浸油电机、阀块、插装阀、油箱集成为一体。采用油浸式电机加叶片泵的设计结构，噪音更低。可叠加多路液压锁，调速阀组合使用。由于噪音小，空间紧凑，被广泛应用于液压货梯等升降设备。电机2.2-5.5KW，电压220-380V可选。

This hydraulic power unit is specially designed for hydraulic cargo elevator and is integrated by high-pressure vane pump, AC oil immersion motor, valve block, cartridge valve and oil tank. The design structure of oil immersed motor and vane pump is adopted, and the noise is lower. Multi channel hydraulic lock can be superimposed and used in combination with speed regulating valve. Due to low noise and compact space, it is widely used in lifting equipment such as hydraulic cargo elevator. The motor is 0.75-5.5kw and the voltage is 220-380v.



### 原理图/SCHEMATIC DIAGRAM

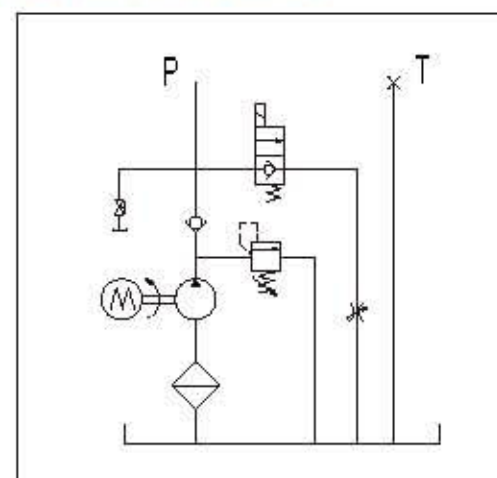

Y3A

### 注意事项/SPECIAL NOTES

- 此动力单元为S3工作制，不可连续运转，10秒开，90秒停。
- 安装前必须保证油缸、油管、接头等液压元件无杂质黏附。
- 液压油粘度应为15-68ST，夏季推荐46号抗磨液压油，冬季推荐32号低温液压油。
- 首次启动运行系统后，应立即检查油箱中的油量是否充足，一般为油箱2/3部位。
- 系统使用第一个100小时后，应更换液压油，以后每3000小时更换一次液压油。
- The power unit is S3 working system and can not operate continuously. It starts in 10 seconds and stops in 90 seconds.
- Before installation, ensure that hydraulic components such as oil cylinder, oil pipe and joint are free of impurities.
- The viscosity of hydraulic oil shall be 15-68st. No. 46 anti-wear hydraulic oil is recommended in summer and No. 32 low temperature hydraulic oil is recommended in winter.
- After starting the operating system for the first time, check whether the oil in the oil tank is sufficient, generally 2 / 3 of the oil tank.
- After the system is used for the first 100 hours, the hydraulic oil shall be replaced, and then the hydraulic oil shall be replaced every 3000 hours.

### 产品配置/SPECIFICATIONS

型号 Model	电压 Volt	功率 Power	转速 Speed	油泵排量 Displacemet	工作压力 Pressure	油箱 Tank	电磁阀电压 Solenoid Vavle Volt
PNC-2.2-A380-4P-2/8-16-25/L-Y3A	380VAC	2.2KW	1400RPM	8CC/REV	16MPA	25L	24/220V
PNC-3-A380-4P-2/10-16-25/L-Y3A		3KW		10CC/REV			
PNC-4-A380-4P-2/12-16-25/L-Y3A				12CC/REV			

说明：如需不同流量、压力、电机功率等系统参数，请联系我司业务员。

Note: if you need system parameters such as pump, pressure and motor power with different flow, please contact our salesman.

## 立体车库静音动力单元

### PARKING GARAGE SILENT POWER UNIT

此液压动力单元专为立体车库设计，由高压叶片泵、交流浸油电机、阀块、插装阀、油箱集成为一体。采用油浸式电机加叶片泵的设计结构，噪音更低。可叠加多路液压锁，调速阀组合使用。由于噪音小，空间紧凑，被广泛应用于液压货梯等升降设备。电机2.2-5.5KW，电压220-380V可选。

This hydraulic power unit is specially designed for three-dimensional parking garage and is integrated by high-pressure vane pump, AC oil immersion motor, valve block, cartridge valve and oil tank. The design structure of oil immersed motor and vane pump is adopted, and the noise is lower. Multi channel hydraulic lock can be superimposed and used in combination with speed regulating valve. Due to low noise and compact space, it is widely used in lifting equipment such as hydraulic cargo elevator. Motor 2.2-5.5kw, voltage 220-380v optional.



### 原理图/SCHEMATIC DIAGRAM

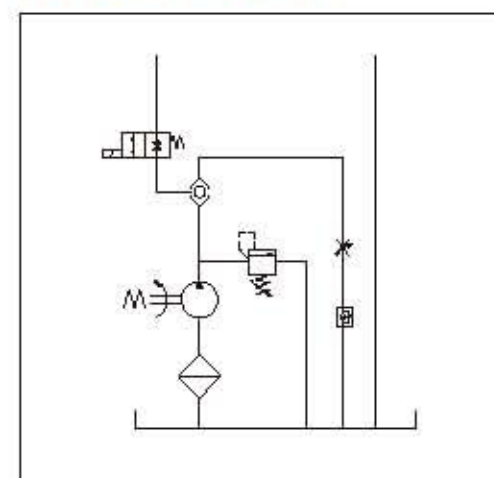

Y24

### 注意事项/SPECIAL NOTES

- 此动力单元为S3工作制，不可连续运转，10秒开，90秒停。
- 安装前必须保证油缸、油管、接头等液压元件无杂质黏附。
- 液压油粘度应为15-68ST，夏季推荐46号抗磨液压油，冬季推荐32号低温液压油。
- 首次启动运行系统后，应立即检查油箱中的油量是否充足，一般为油箱2/3部位。
- 系统使用第一个100小时后，应更换液压油，以后每3000小时更换一次液压油。
- The power unit is S3 working system and can not operate continuously. It starts in 10 seconds and stops in 90 seconds.
- Before installation, ensure that hydraulic components such as oil cylinder, oil pipe and joint are free of impurities.
- The viscosity of hydraulic oil shall be 15-68st. No. 46 anti-wear hydraulic oil is recommended in summer and No. 32 low temperature hydraulic oil is recommended in winter.
- After starting the operating system for the first time, check whether the oil in the oil tank is sufficient, generally 2 / 3 of the oil tank.
- After the system is used for the first 100 hours, the hydraulic oil shall be replaced, and then the hydraulic oil shall be replaced every 3000 hours.

### 产品配置/SPECIFICATIONS

型号 Model	电压 Volt	功率 Power	转速 Speed	油泵排量 Displacemet	工作压力 Pressure	油箱 Tank	电磁阀电压 Solenoid Vavle Volt
PNC-4-A380-4P-2/8-25-40/L-Y24	380VAC	4KW	1400RPM	8CC/REV	25MPA	40L	24/220V
PNC-5.5-A380-4P-2/13-16-60/L-Y24		5.5KW		13CC/REV		60L	

说明：如需不同流量、压力、电机功率等系统参数，请联系我司业务员。

Note: if you need system parameters such as pump, pressure and motor power with different flow, please contact our salesman.