

Authorized Distributor
713.725.7115

EXP Bearing Isolator

The revolutionary hybrid design of the EXP Bearing Isolator merges proven labyrinth technology with a new generation of Expeller Technology and allows users to achieve performance levels as never before.

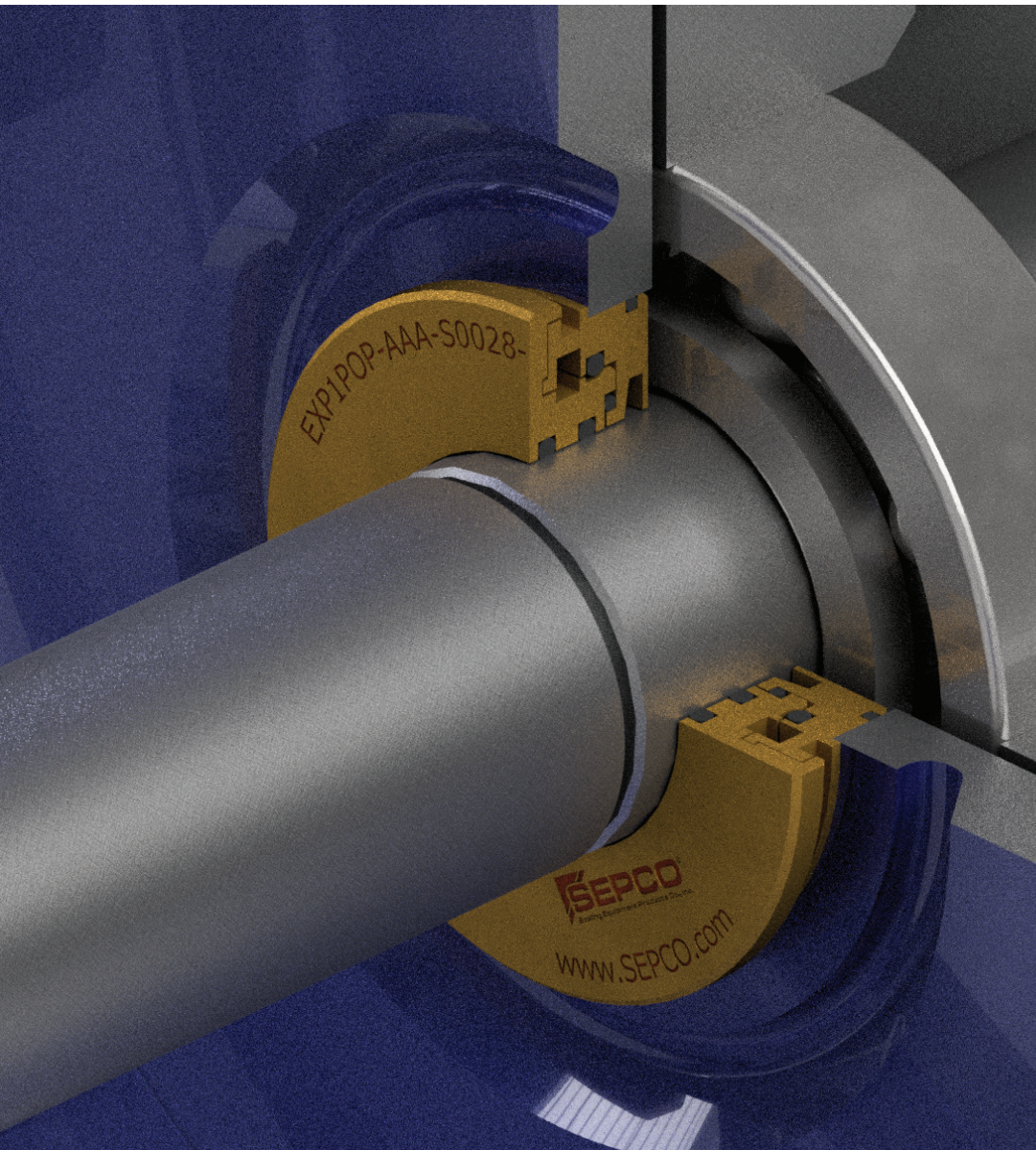

BENEFITS

The EXP maximizes bearing life and significantly reduces operating costs—save on:

- Lubricants
- Oil changes
- Labor and overtime
- Bearing replacements
- Equipment failures
- Downtime
- Worn shafts

CONDITIONS SEALED

- Oil mist
- Flooded oil
- Grease
- Forced lubrication

Enjoy the reliable seal performance of the SEPCO EXP for the life of your equipment!

The No. 1 cause of rotating equipment failure is bearing failure.
 The No. 1 cause of bearing failure is lubrication contamination.
 The No. 1 solution is EXP.

Rotating equipment is the heart of industry and lubricating oil is its lifeblood. When lubricants fail, machines break down, and your process screeches to a halt.

The number one cause of failure is lubrication contamination. Lubricants can provide years of protection against wear when they are kept clean and dry. The struggle to achieve months or even weeks of service life between oil changes is because of contamination ingress.

- Do you have visible dirt and water in your oil?
- Do you see elevated water and particle contamination trends in your oil analysis?
- Are you experiencing bearing failures?

If you didn't pour dirty oil into your machine, then the most common pathway is a failed oil seal. The SEPCO EXP Bearing Isolator solves this problem in the toughest applications.

THE IMPORTANCE OF BEARING PROTECTION*

Reliability-conscious companies know that eliminating lubrication contamination sources delivers the greatest reliability impact with the best return on investment.

FACT: Only 10% of bearings ever reach their L10 life before failing or being replaced.

FACT: 63% of bearing failures are caused by lubrication related wear issues; 52% of bearing failures are because of oil contamination.

FACT: 70% of lost machine life is caused by surface degradation:

- 50% from mechanical wear
- 20% from machine surfaces corrosion

FACT: Mitigation of mechanical wear and corrosion are two of the primary functions of lubricants

FACT: 82% of mechanical wear is caused by particle contamination

*Sourced from multiple studies conducted by SKF, MIT, NRCC, and STLE. Data compiled from studies conducted across several industries, including pulp and paper, mining, forestry, transportation, and power generation.

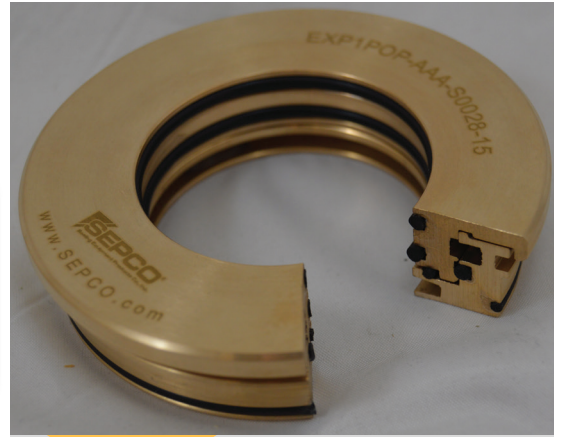

WHY THE EXP WORKS

It is a true noncontact bearing isolator. Using centrifugal force, it adds energy to the contaminants to deflect them away from the bearing housing while effectively retaining lubrication. Two static internal coalescing O-rings exclude vapor ingress by breaking it down and directing it to the contamination expeller chamber. It can be split for ease of installation.

- ✓ Expels contaminants
- ✓ Eliminates lubrication leakage
- ✓ Prevents water contamination

CAUSES OF BEARING FAILURE

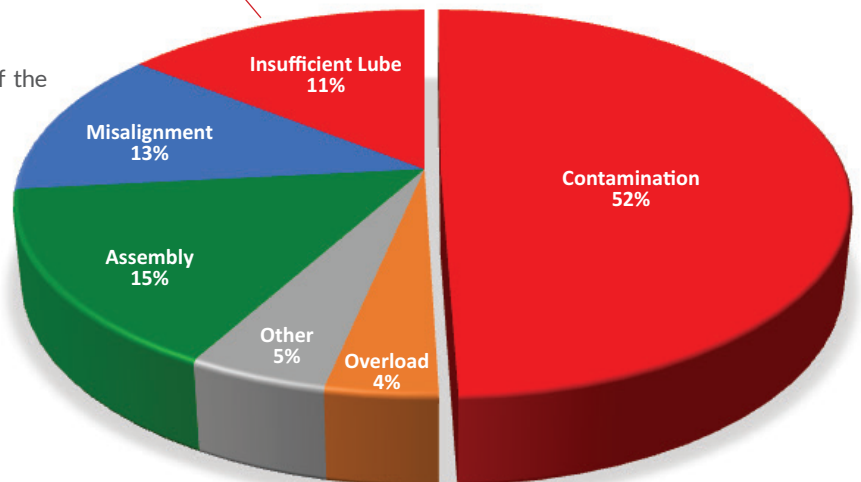

SEALING EFFECTIVENESS OF POPULAR DESIGNS

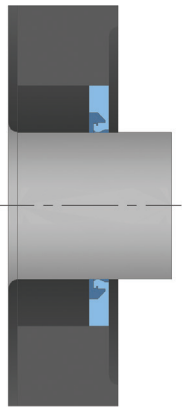

Lip Seals

High contaminant ingress

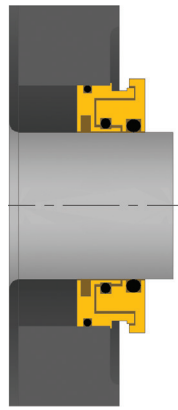
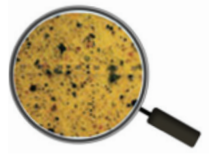

Labyrinth Seals

Lower contaminant ingress

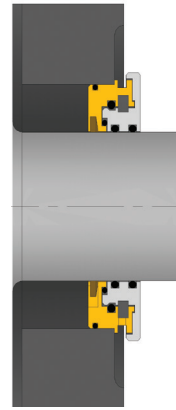
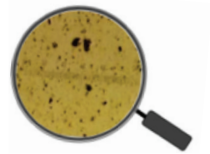

EXP Bearing Isolator

No contaminant ingress

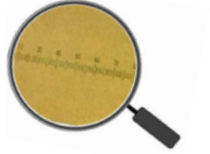

EXP BEARING ISOLATOR VARIATIONS

EXP

For standard-mount applications

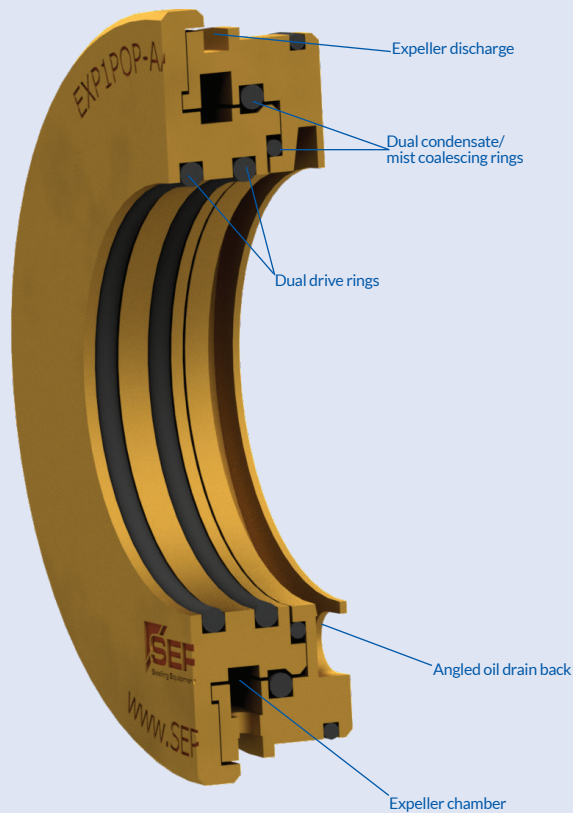

EXP-TB

For steam turbines in which steam is coalesced before it reaches the bearing housing

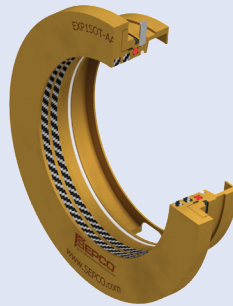

EXP-GB

For gearboxes where a positive seal is required due to flooded conditions

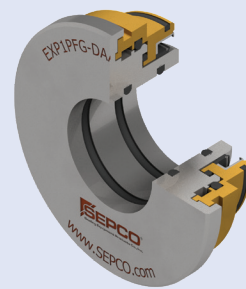

EXP-FL

For flange-mount applications for which a more secure mount is recommended

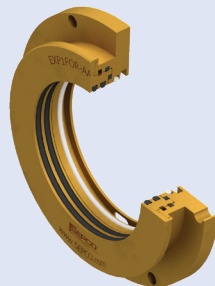

EXP-PB

For pillow block housings specifically fitting the groove for the LER/LOR ring

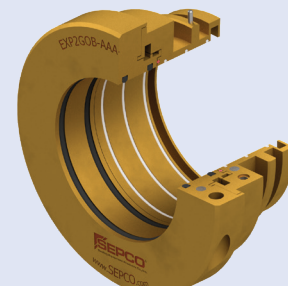

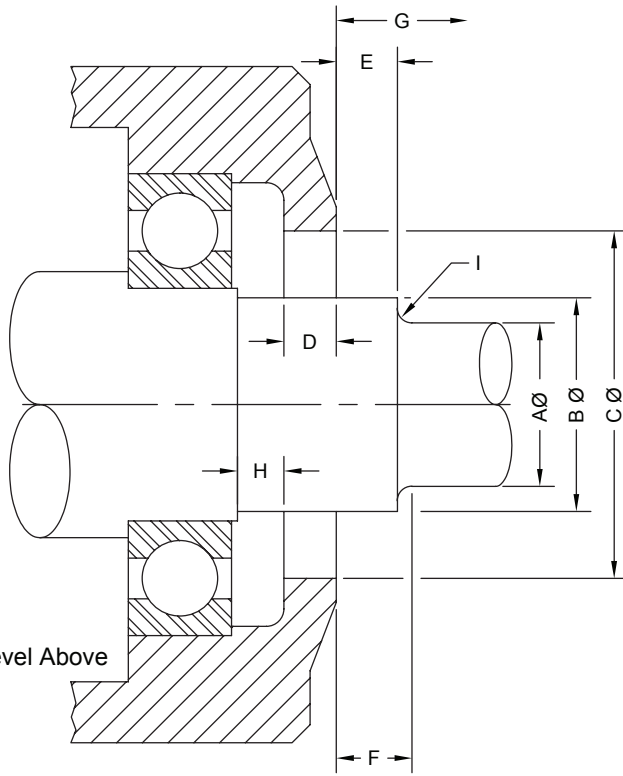

EXP APPLICATION DATA

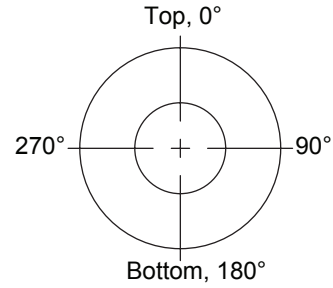

*Indicate Oil Level Above

Company name _____
 Location _____
 Contact name _____
 Contact number _____
 Email _____

Application: Pump Motor Gearbox
 Other: _____

Equipment make/model _____

Operating environment _____

RPM _____

Shaft orientation Horizontal Vertical

Shaft axial movement _____

Shaft TIR _____

Shaft/bore TIR _____

Temperature _____ °F / °C

Lubrication Oil Grease Oil mist
 Circulating

Isolator configuration Solid Split
 Press-fit Flange mount **

Material of construction Bronze S.S.
 Other: _____

O-ring material Viton Other: _____

A _____ Step shaft

B _____ Shaft

C _____ Bore

D _____ Housing depth

E _____ Distance to step start

F _____ Distance to step end

G _____ Distance to first obstruction

H _____ Distance to step or bearing

I _____ Radius

Mount Type

Horizontal

Vertical top

Vertical bottom

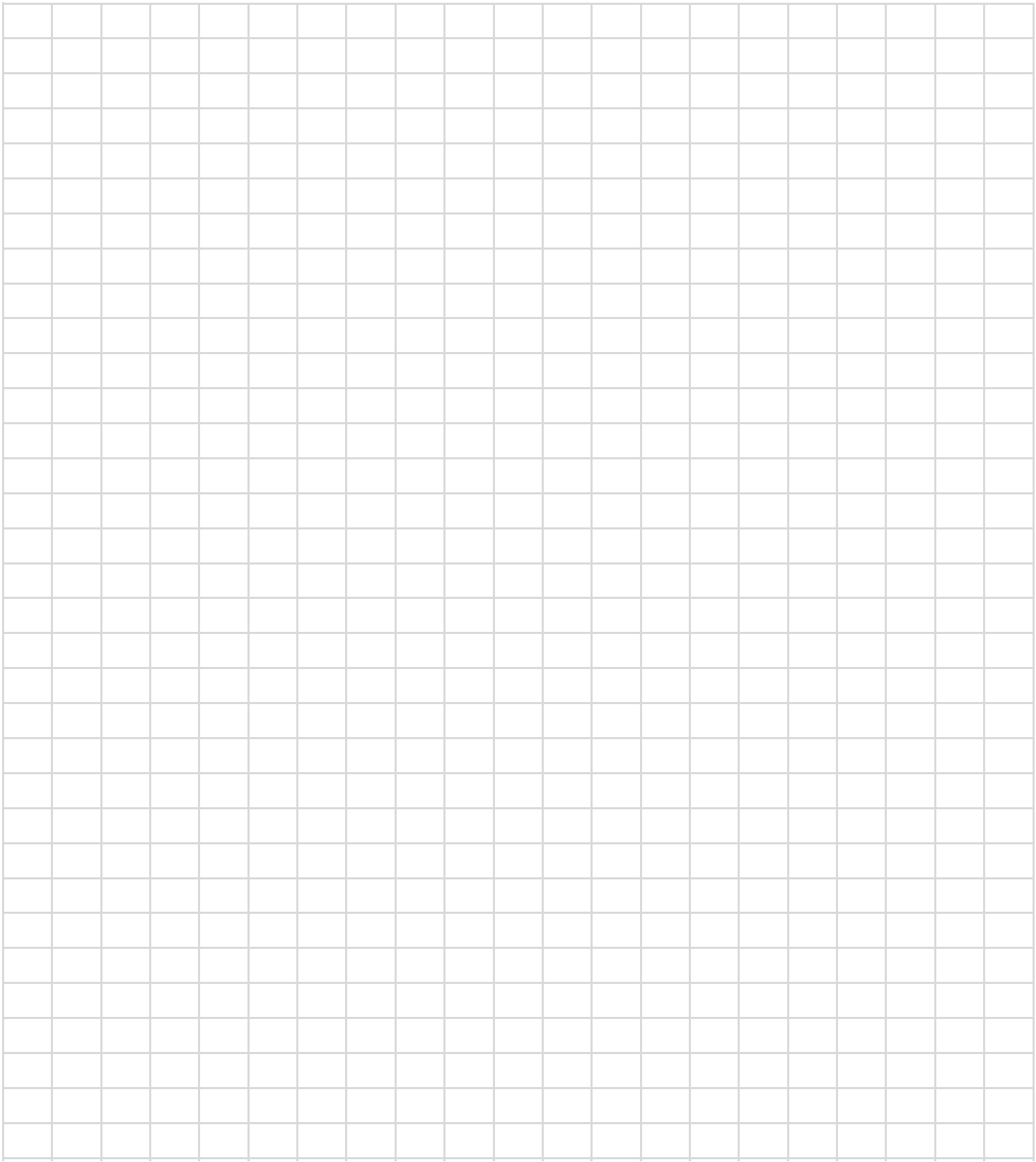

713.725.7115

www.oneteamproducts.com

Sales Contact
Scan Code with
Smart Phone

