

Protect your volatile liquid storage tanks and surrounding property with Tokheim Flame Arresters.

Tokheim Flame Arresters are designed to be used at the termination of the vent pipe which vents volatile vapors directly to the atmosphere. Vapors passing through the stacks, if ignited from an outside source, will burn like a gas water heater or furnace. The fire cannot flash through the stacks into the tank. When the pressure inside the tank diminishes the fire will die out, much like shutting off the valve on a water heater or furnace.

Tokheim Flame Arresters consist of a cast iron base, cover and posts, plus aluminum weather shields and plate stacks. The plates are 0.061" thick and are spaced 0.020" apart to make the stack. Other plate dimensions are as follows:

model	width	length	height of plate stack
* 85-2"	4-5/8"	round	2-7/16"
* 85-3"	1-1/4"	4-3/8"	5-1/4"
85-4"	1-1/4"	4-3/8"	5-1/4"
85-6"	1-1/4"	4-3/8"	5-1/4"
85-8"	1-1/4"	4-3/8"	7"
85-10"	2"	4-3/8"	9-1/4"

* Tokheim Flame Arresters that are UL listed. (Flow capacity in cubic feet per hour at 14.7 psi and 22° C.)

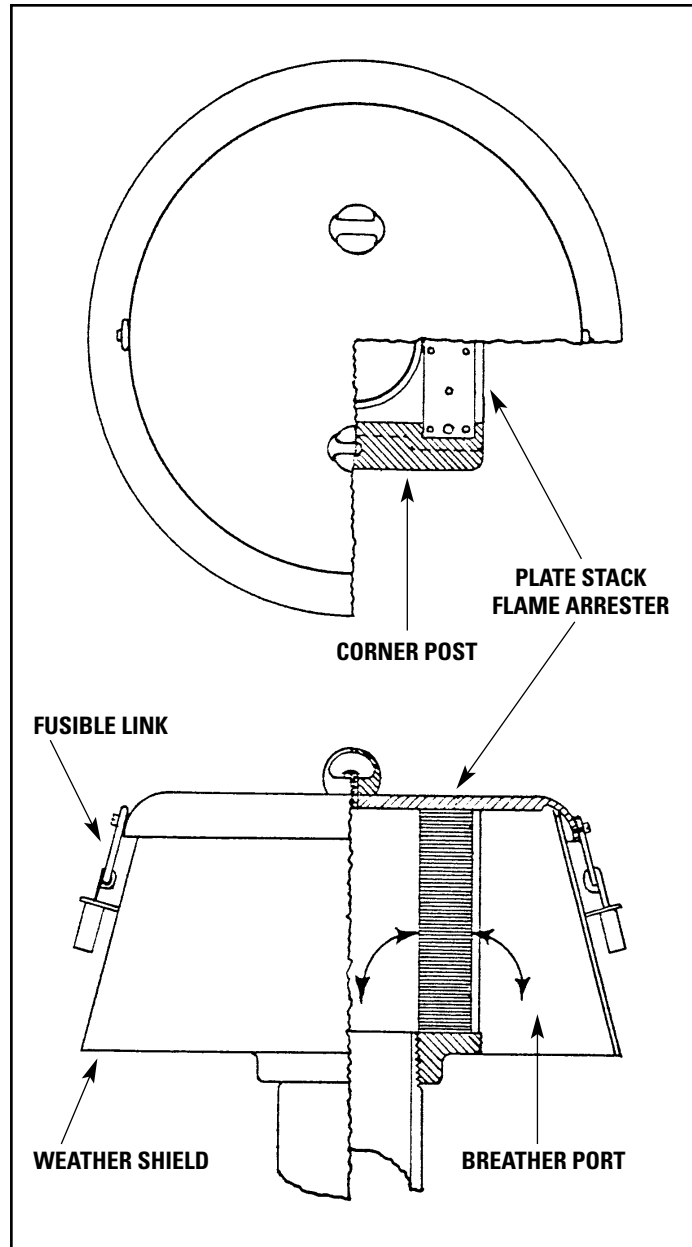

Installation

Be sure plate stacks and base are free of any packing materials.

Apply pipe sealer to pipe nipple and screw arrester on pipe by hand. Then tighten securely with a pipe wrench applied to base of unit.

Maintenance

It is very important that the vent pipe to which the flame arrester is attached be extended a safe distance above ground and if it is near a building it should be extended above the roof. Flame arresters have no moving parts, however it is important to inspect and clean the plate stacks periodically.

To inspect, remove nuts on top of cover and lift cover off. Remove plate stacks and inspect by holding up to light. Spaces between plates should be open.

To clean plate stacks, immerse in warm soapy water and agitate to remove dirt. Rinse well with hot water and blow dry with compressed air. Clean base and cover of unit with soft cloth dampened with naphtha. Replace plate stacks and cover, tightening nuts firmly.

The Tokheim Company 319-362-4847 www.tokheimco.com info@tokheimco.com

Manufacturers of Quality Storage Tank Equipment Since 1898.

- Aboveground Tank Gauges
- Underground Tank Gauges
- Guided Float Kits
- Pressure-Vacuum Vents (2, 4, 6, 8, & 10 inch sizes)
- Flame Arresters (2, 3, 4, 6, 8, & 10 inch sizes)
- Combination Units of Flame Arrester & Pressure-Vacuum Vent (2, 4, 6, 8, & 10 inch sizes)
- Sampling Pumps
- Overfill Alarms