



**KAAM TOOLS**  
by **AJAY INDUSTRIES**

**HIGH QUALITY  
CAULKING GUN  
MANUFACTURER**

## ABOUT COMPANY

AJAY INDUSTRIES laid its foundation stone in 1974 in the city of Ludhiana which is the Manchester City of India . Mr. Ashok Kumar Sital and Mr. Ajay Kumar Sital started with the motive to serve the Indian Domestic as well as International Markets .

As the business was growing with the entrance of new generation, Mr. Ajay Kumar Sital along with Mr. Maulik Sital extended business to MNC's for different types of Industrial and consumer products.

### VISION

To be a global connecting force in the industry, we believe in a complete vertical organization with values based on honesty, reliability and professionalism.

### MISSION

Commit to professionalism and business excellence, fortifying existing relations and attract customers by providing superior services. Being strategically focused on opportunities and emergent technology thereby enhancing production, growth and specialization.

## OUR EXPERTISE

All the processes starting from sheet-metal, aluminium and zinc alloy processing till packing are in-house. Specialist in Hot and Cold Chamber Pressure Die Casting , Sheet Metal processing .

We manufacture all possible qualities of our products based on customers demand.

## OUR HIGHLIGHTS

We are reducing our Net Carbon Emissions by 75% by the of Year 2022 by installing solar power plant that fulfils power-demands of our manufacturing unit.

## SOCIAL & ENVIRONMENT RESPONSIBILITY

As a responsible organization, AJAY INDUSTRIES firmly believes that social and environmental accountability is of utmost importance to nurture a positive work culture and sustainable growth. In line with our values, creativity, enthusiasm we are strongly committed to our responsibilities of being a healthy part of our society.

### TOWARDS ENVIRONMENT

We are a proud Eco friendly unit with below specialties:

- Low Dependency on Power supply grids
- Low Carbon Emissions

## SK- 410G

- MADE OF MILD STEEL SHEETS
- THRUST RATIO 6:1
- HEX ROD
- AVAILABLE FOR 300ML and 400ML TUBES
- EASY TO USE PRODUCT
- FOR USE WITH LOW TO MEDIUM VISCOSITY SEALANT
- IDEAL FOR PROMOTIONAL PACKAGES



## SK- 410G DC

- TWIN COLOUR MODEL.
- MADE OF MILD STEEL SHEETS
- THRUST RATIO 6:1
- HEX ROD
- AVAILABLE FOR 300ML AND 400ML TUBES
- EASY TO USE PRODUCT
- FOR USE WITH LOW TO MEDIUM VISCOSITY SEALANT
- IDEAL FOR PROMOTIONAL PACKAGES



## SK- 420G

- FRAME THICKNESS ↑20%.
- MADE OF MILD STEEL SHEETS
- THRUST RATIO 6:1
- HEX ROD
- AVAILABLE FOR 300ML AND 400ML TUBES
- EASY TO USE PRODUCT
- FOR USE WITH LOW TO MEDIUM VISCOSITY SEALANT
- IDEAL FOR PROMOTIONAL PACKAGES





## SK- 440G DC LHP

- FRAME THICKNESS ↑20%, TWIN COLOUR, INCLUDES LADDER HOOK, AND DE- CLOGGING PIN
- MADE OF MILD STEEL SHEETS
- THRUST RATIO 6:1
- HEX ROD
- AVAILABLE FOR 300ML AND 400ML TUBES
- EASY TO USE PRODUCT
- FOR USE WITH LOW TO MEDIUM VISCOSITY SEALANT
- IDEAL FOR PROMOTIONAL PACKAGES

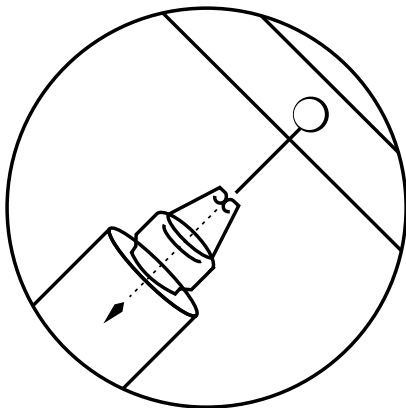

DE- CLOGGING PIN



LADDER HOOK





## HR- 420G DC LH P

- THICKER WIDE FRAME, TWIN COLOURS, LADDER HOOK AND DE-CLOGGING PIN
- MADE OF MILD STEEL COLD ROLLED SHEETS
- THRUST RATIO 5:1
- SMOOTH ROD
- AVAILABLE FOR 300ML
- EASY TO USE PRODUCT
- FOR USE WITH LOW TO MEDIUM VISCOSITY SEALANT
- IDEAL FOR PROMOTIONAL PACKAGES

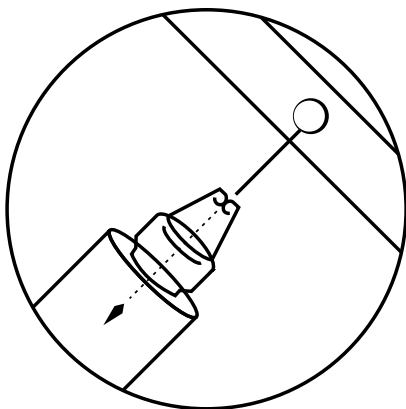

DE CLOGGING PIN

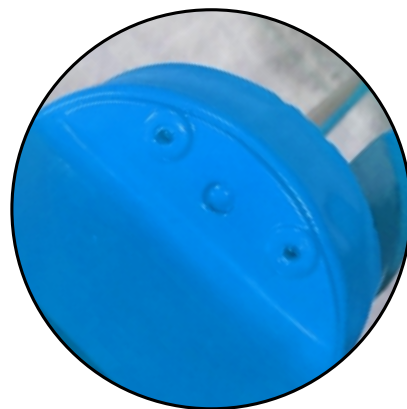

RIVETTED BODY AND HANDLE

## HR-370G

- MADE OF MILD STEEL COLD ROLLED SHEETS
- THRUST RATIO 5:1
- SMOOTH ROD
- AVAILABLE FOR 300ML & 400ML TUBES
- EASY TO USE PRODUCT
- FOR USE WITH LOW TO MEDIUM VISCOSITY SEALANT
- IDEAL FOR PROMOTIONAL PACKAGES



## HR-370G DC

- TWIN COLOUR MODEL.
- MADE OF MILD STEEL COLD ROLLED SHEETS
- THRUST RATIO 5:1
- SMOOTH ROD
- AVAILABLE FOR 300ML & 400ML TUBES
- EASY TO USE PRODUCT
- FOR USE WITH LOW TO MEDIUM VISCOSITY SEALANT
- IDEAL FOR PROMOTIONAL PACKAGES



## HR-400G

- WIDER FRAME SIZE.
- MADE OF MILD STEEL COLD ROLLED SHEETS
- THRUST RATIO 5:1
- SMOOTH ROD
- AVAILABLE FOR 300ML
- EASY TO USE PRODUCT
- FOR USE WITH LOW TO MEDIUM VISCOSITY SEALANT
- IDEAL FOR PROMOTIONAL PACKAGES



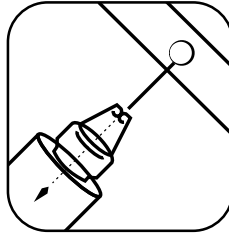
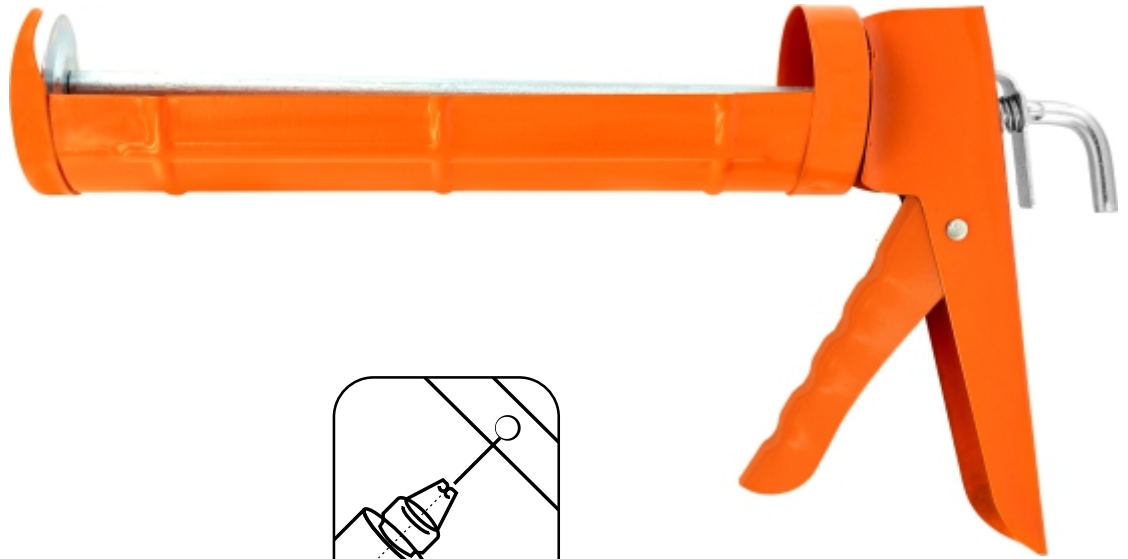

## HR-420G P

- COMES WITH DE-CLOGGING PIN
- THRUST RATIO 5:1
- SMOOTH ROD
- AVAILABLE FOR 300ML
- EASY TO USE PRODUCT
- FOR USE WITH LOW TO MEDIUM VISCOSITY SEALANT
- IDEAL FOR PROMOTIONAL PACKAGES



## HR-400G DC LH

- COME WITH WIDER FRAME,
- LADDER HOOK
- TWIN COLOUR MODEL.
- THRUST RATIO 5:1
- SMOOTH ROD
- AVAILABLE FOR 300ML
- EASY TO USE PRODUCT
- FOR USE WITH LOW TO MEDIUM VISCOSITY SEALANT
- IDEAL FOR PROMOTIONAL PACKAGES



## ASK-390G

- MADE OF ALUMINIUM ALLOY AND MILD STEEL
- THRUST RATIO 7:1
- HEX ROD
- EASY TO USE PRODUCT
- LIGHTWEIGHT YET STURDY
- AVAILABLE FOR 300ML and 400ML TUBES
- FOR USE WITH LOW TO MEDIUM VISCOSITY SEALANT
- PRODUCT MADE AS PER INTERNATIONAL BENCHMARKS
- IDEAL FOR DIY USERS AND INTERNATIONAL MARKETS



## ASK-390G DC

- TWIN COLOUR MODEL
- MADE OF ALUMINIUM ALLOY AND MILD STEEL
- THRUST RATIO 7:1
- HEX ROD
- EASY TO USE PRODUCT
- LIGHTWEIGHT YET STURDY
- AVAILABLE FOR 300ML AND 400ML TUBES
- FOR USE WITH LOW TO MEDIUM VISCOSITY SEALANT
- PRODUCT MADE AS PER INTERNATIONAL BENCHMARKS
- IDEAL FOR DIY USERS AND INTERNATIONAL MARKETS

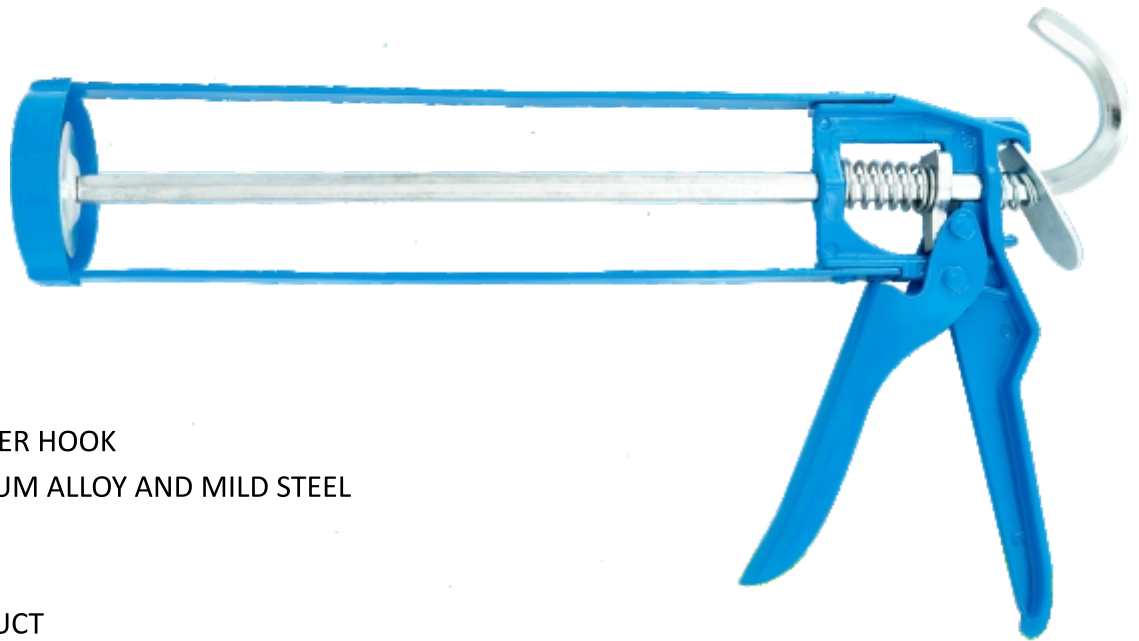

## ASK-410G LH

- COMES WITH LADDER HOOK
- MADE OF ALUMINIUM ALLOY AND MILD STEEL
- THRUST RATIO 7:1
- HEX ROD
- EASY TO USE PRODUCT
- LIGHTWEIGHT YET STURDY
- AVAILABLE FOR 300ML & 400ML TUBES
- FOR USE WITH LOW TO MEDIUM VISCOSITY SEALANT
- PRODUCT MADE AS PER INTERNATIONAL BENCHMARKS
- IDEAL FOR DIY USERS AND INTERNATIONAL MARKETS



## ASK-390 DDG

- COMES WITH DOUBLE FEED DOG, FOR EXTRA THRUST.
- COME WITH WIDER FRAME,
- LADDER HOOK
- THRUST RATIO 9:1
- HEX ROD
- AVAILABLE FOR 300ML & 400ML TUBES
- EASY TO USE PRODUCT
- FOR USE WITH LOW TO MEDIUM VISCOSITY SEALANT





## ASK-410G DC LHP

- COME WITH TWIN COLOUR, LADDER HOOK AND DE CLOGGING PIN
- COMES WITH DE-CLOGGING PIN
- THRUST RATIO 7:1
- HEX ROD
- AVAILABLE FOR 300ML AND 400ML TUBES
- EASY TO USE PRODUCT
- FOR USE WITH LOW TO MEDIUM VISCOSITY SEALANT
- IDEAL FOR DIY USERS AND INTERNATIONAL MARKETS

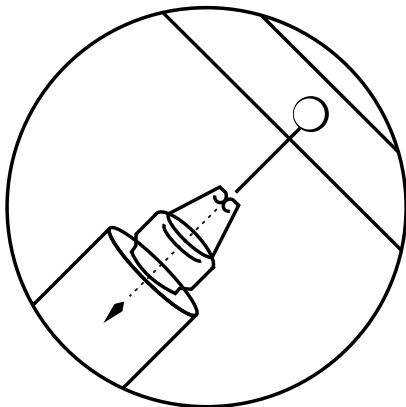

DE- CLOGGING PIN



LADDER HOOK



## ZD-420G DC

- NOISELESS, NO DRIP, TWIN COLOUR
- MADE OF MILD STEEL COLD ROLLED SHEETS
- THRUST RATIO 5:1
- SMOOTH ROD
- EASY TO USE PRODUCT
- AVAILABLE FOR 300ML TUBES
- ZERO-DRIP MECHANISM ALLOWS HIGH-QUALITY CAULKING
- FOR USE WITH LOW TO MEDIUM VISCOSITY SEALANT
- PRODUCT MADE AS PER INTERNATIONAL BENCHMARKS
- IDEAL FOR PROFESSIONAL APPLICATION PURPOSES



## ZD-440G DC LHP

- NOISELESS, NO DRIP, TWIN COLOUR WITH LADDER HOOK AND DE CLOGGING PIN
- MADE OF MILD STEEL COLD ROLLED SHEETS
- THRUST RATIO 5:1
- SMOOTH ROD
- EASY TO USE PRODUCT
- AVAILABLE FOR 300ML TUBES
- ZERO-DRIP MECHANISM ALLOWS HIGH-QUALITY CAULKING
- FOR USE WITH LOW TO MEDIUM VISCOSITY SEALANT
- PRODUCT MADE AS PER INTERNATIONAL BENCHMARKS
- IDEAL FOR PROFESSIONAL APPLICATION PURPOSES

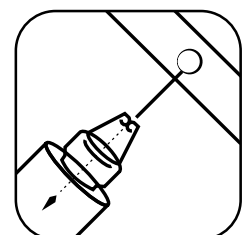

WE PROVIDE A VARIETY OF OPTIONS WHEN IT COMES TO PACKAGING OF PRODUCTS  
FEW OF THE OPTIONS WE OFFER ARE AS FOLLOWS:



COLD STAMPING OF BRANDS LOGO



PAD PRINTING OF BRANDS LOGO



PRINTED HANGING TAGS

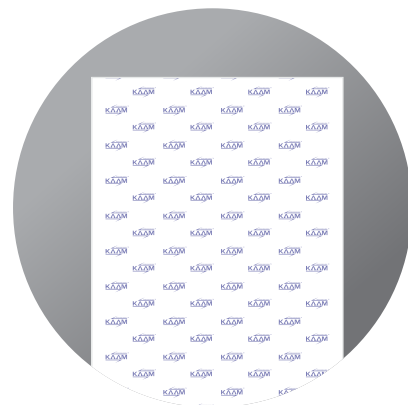

BRAND SPECIFIC POUCHES AND BAGS



BRANDED BOX PACKING PRINTED/  
MULTI-COLOUR / MONO-TONE



CUSTOMISABLE PAINT SELECTION

## WALNUT CRACKERS

ALUMINIUM DIE CASTED WALNUT CRACKERS FOR CRACKING WALNUT SHELLS



MADE FROM GRADED ALUMINIUM ALLOY | IDEAL FOR WALNUT CRACKING UPTO 45MM  
EASY TO USE | FOR HOUSEHOLD AS WELL AS BULK CRACKING

## ALUMINIUM & ZINC ALLOY HIGH PRESSURE DIE CASTING



## SHEET METAL COMPONENTS





## SAUSAGE TYPE

- WILL COME IN 300ML, 400ML, 600ML
- ALUMINIUM ANODISED TUBE
- SMOOTH ROD
- THRUST RATIO 11:1
- WILL ALSO BE AVAILABLE WITH DOUBLE FEED DOG



## AHR- 500

- WILL COME IN 300ML, 400ML
- SMOOTH ROD
- THRUST RATIO 11:1
- WILL ALSO BE AVAILABLE WITH DOUBLE FEED DOG





A series of horizontal lines for writing, consisting of 20 evenly spaced lines across the page.

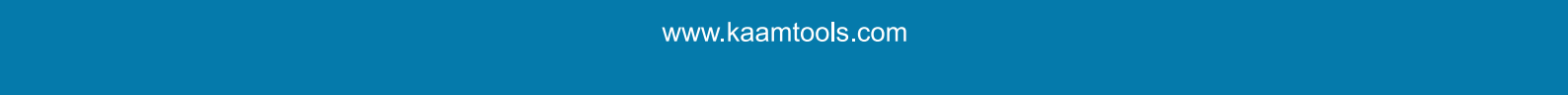

## KAAM TOOLS by AJAY INDUSTRIES

E-480, Phase VI, Focal Point Ludhiana 141010 (Punjab) INDIA

Ph: +91 9646716964, 9815559591

L.L Ph: +91-161-2922480

E-Mail: [sales@kaamtools.com](mailto:sales@kaamtools.com) | [ajayinds@kaamtools.com](mailto:ajayinds@kaamtools.com)

Web: [www.kaamtools.com](http://www.kaamtools.com)

