

# David Manteit V Brisbane City Council 2916/24

## Further submissions for Trial

### Deeming of hydraulic lines and conditions unlawful

1. The Appellant seeks the determination by the Court that the red stormwater lines and conditions 7 and 18 are removed from the approval, upon the commencement of the hearing, or before.
2. The Appellant seeks the Court's determination at the first instance in the Hearing that the 81 metres of hydraulic red lines, pits and kerb adaptors drawn on the approved plan by the Council employees for Upstream and Onsite Drainage are declared unlawful and illegal, due to there being no RPEQ hydraulic licence attached or signed off, of the plans. A hydraulic stormwater licence being an RPEQ licence.
3. The red lines and conditions 7 and 18 are to be removed immediately by the Court, at the hearing. From that moment on, the red lines are to be referred to as "sketches" for discussion only, as similarly described in the Appellant independent engineer report.
4. It is my submission that it is untenable for the Court to discuss any unlawful condition, at the hearing, as if it were lawful.
5. The Appellant is very interested in discussing and pursuing all matters, especially the matters of unsatisfactory professional conduct, under schedule 2 and 115 of the Professional Engineers Act, which may be a criminal offence, or Criminal conduct as per S15 (1) of the Crime and Corruption Act.
6. The Appellant now declares that the hydraulic plans are not signed off by any of the "Council employees", or any RPEQ person, which is in contravention of S115(1) of the Professional Engineers Act 1002. I request that this Court finds the same conclusion, at the first instant, for the purpose of advancing the hearing, and other adverse findings and arguments for any other matters.

7. The Council employees not only have allegedly committed offences themselves for unlicensed engineering but leave a trail of destruction in their wake, by forcing the real RPEQ engineers to commit offences of up to \$725,000 by the real engineer having to guess what is complying with the Council employees illegal plans.

(a) In the case of Onsite Drainage there is no guessing. It is a fine of \$725,000 for building a pipe to the low side of the kerb, by complying with S7.6.2, BSD 8111 and BSD 8113, but not complying with S164 of the Planning Act in contravening the Development permit.

(b) Should the real engineer at 5.1m from the low side of the kerb, there could be hundreds of thousands of dollars fines by designing / building at the at 5.1m from the low side of the kerb and not complying with Council laws.

This Council employees are hell bent on keeping (b). This sham has to end. The Onsite Drainage red lines have to go. The Council employees actions must be held to account for this shameful unlicensed engineering. These sort of reckless actions must be stamped out immediately.

8. With respect, His Honour refused on 12/4/25 the Appellant's request for the seven Council employees to be a witness at the hearing. The hearing at which would have been the last chance for the witnesses, being the "Council employees" to provide the said RPEQ licence number. That chance is now gone, by default, due to the determination by the Court.

There is no fault caused by the Appellant. There is simply no more chances for Council employees to declare that they have signed off the hydraulic stormwater plans with an RPEQ licence.

9. Mr Manteit requested the Court for orders on 14/4/24, extract below -

In addition the following proof is required:

The stormwater pipes would not be charged at any point.

The flow is less than 30 l/s at the kerb.

The engineering complies with all Council laws and QUDM

The engineering complies with the Rational Method.

The names of the person/s who engineered the stormwater systems

There were no unlicensed engineers who performed engineering

There would be no downstream flooding, causing damage to people and property. (QUDM).

Assessment of engineering was carried out with due diligence and not gross negligence.

These above proposed orders by the Appellant were denied by the Court.

10. It was discussed, however, with His Honour, with the Appellant and it was expected by His Honour (The Appellant is not saying guaranteed, or certain, or ordered) that the Respondent would provide this information to the Appellant, on 22/4/25.
11. It was mentioned to His Honour that David Manteit has asked for the RPEQ licenced since 1/10/24 from 5 of the 7 Council employees.
12. The Appellant has generously offered the said Council employees seven months of chances to “come clean” and advise Manteit and the Court who the licenced RPEQ person was that prepared and performed engineering of the approved plans and their RPEQ licence number. There is no RPEQ signoff on those hydraulic plans.
13. It can therefore now be declared that these stormwater plans are unlawful and illegal due to no RPEQ licence sign off attached to the hydraulic stormwater plans. There are offences, including criminal offences that may apply from various bodies.
14. David Manteit advised the Court on 12/12/24 that unless another engineer knew what the red lines were, the surface levels and invert levels and other engineering information from the author of the red lines, then any discussions by other engineers may take hundreds of hours to identify what the engineering makeup of the red lines is, due to the incompetence of Council employees’ design and no RPEQ signoff.
15. S45 of the Planning Act provides for the Appellant to prove his assertions. That is correct. The first proof argued by the Appellant is that the red lines and conditions are illegal and they must be removed along with Conditions 7 and 18 S45 done.
16. Condition 7 and 18 are unlawful due to there not being any signoff RPEQ licence and therefore must be removed at the commencement of the trial.
17. In 412 Council approved cases audited last calendar year, there were no approvals that Council nominated in the conditions a hydraulic plan amended in red that did not have an RPEQ signoff.
18. That is the standard expected by Brisbane City Council. That is the standard expected in Schedule 2 of the Professional Engineers Act.

19. It is untenable for the Court to return any red line to the Council as the red line would not comply with Brisbane City Council own standards, of RPEQ licence required.

## **Below is an example of Excellent Council employee conduct.**

20. Council employee Erik Christenson wrote to the applicant of 22 Parnassus St Robertson, on 25/7/24, requesting the applicant engineer to design an Upstream Connection.

This request was 15 days after Manteit lodged his application on 10/7/24 and 2 days after Manteit application was properly made on 23/7/24.

The Council employees for 128 Ashridge Rd Darra would have known of the correct procedures that Mr Christenson does, but chose to become unlicensed engineers themselves without an RPEQ licence, and commit alleged criminal offences.

Mr Christenson has chosen not to engineer himself. Good work, Mr Christenson.

**Erik Christenson has proven to be an excellent Council employee, who knows Council Codes and Standards, and an RPEQ is required for the red lines.**

**The Respondent says his excellent actions are just "hearsay"**

The Appellant, by virtue of their objection responses, the following is alleged -

Basically the Respondent allegedly says this Council employee Mr Christenson is not to be believed under any circumstances. His word is hearsay.

Basically, the Respondent allegedly says that we must trust the word of the 128 Ashridge Rd Darra application Council employees who have committed offences and performing engineering without an RPEQ licence.

Is there anymore evidence this Court needs of unlicensed engineering by the Council employees of 128 Ashridge Rd Darra.

**Respondent allegedly says -**

Trust these Council employees who perform engineering without a RPEQ licence and commit offences  
81 metres of red pipes  
No Council laws followed  
Whatever.

Roger Greenway  
Andrew Blake  
Lucy Ting  
Zarndra Piper  
Joel Wake  
Scott Ruhland  
.Margaret Orr

It is alleged that the Respondent is trying to hoodwink the Court into believing that the conduct of the Council employees does not attract criminal offences.

It is alleged that the Respondent wants to make the illegal and criminal actions of the Council employees swept under the carpet.

There can be no better example than 22 Parnassus St Robertson to demonstrate what a proper Council employee of good conduct does.

**Respondent allegedly says -**

Don't Trust Mr Christensen – his words are only hearsay.  
This person is irrelevant.

Mr Christenson, asks the applicant to use RPEQ an RPEQ engineer engineer to draw plans and demonstrate Council Codes and Planning Scheme Policies.  
Mr Christenson action is hearsay



*Dedicated to a better Brisbane*

Brisbane City Council ABN 72 002 765 795

**City Planning & Sustainability  
Development Services**  
Brisbane Square, 266 George Street, Brisbane Qld 4000  
GPO Box 1434 Brisbane QLD 4001  
T 07 3403 8888  
[www.brisbane.qld.gov.au](http://www.brisbane.qld.gov.au)

29 July 2024

Mr Jason Qiao  
C/- Ultimate Planning Solutions  
4/113 Scarborough Street  
SCARBOROUGH QLD 4020

**ATTENTION: Marvin Wright**

**Application Reference:** A006548093  
**Address of Site:** 22 PARNASSUS ST ROBERTSON QLD 4109

Dear Marvin

**RE:** Information request under the *Planning Act 2016*

Council has carried out an initial review of the above application and has identified that further information is required to fully assess the proposal.

**1) Stormwater Upstream Connection**

Specialist assessment has found that PO11 of the Stormwater code is not addressed in the Code assessment report. To ensure compliance against the code

- a.) Provide engineering drawings demonstrating upstream connection complying with performance outcome PO11 of the Stormwater code. The proposal must comply with Brisbane Planning Scheme codes, planning scheme policies and must be certified by a registered professional engineer of Queensland.

**2) Erosion Hazard Assessment**

An Erosion Hazard Assessment (EHA) form has not been completed contrary to 7.11.2.1 of the ID PSP.

- a.) Complete and submit an EHA form (available on Council's website) by a suitably qualified consultant.

**3) Existing Structures**

It is unclear if the existing structures including the dwelling house, garage, pavers and pool are to be retained after subdivision.

- a.) Submit amended plans notating removal of the dwelling house, garage, pavers and pool.

-2-

**Responding to this request**

Your response should include a summary table which outlines any changes to performance outcomes and plans that have resulted from addressing the issues outlined above. The table should also include details of any supporting documentation.

If a response is not provided within the prescribed response period of three (3) months assessment of the application will continue from the day after the day on which the response period would have otherwise ended.

Email your response to [DSPlanningSupport@brisbane.qld.gov.au](mailto:DSPlanningSupport@brisbane.qld.gov.au) quoting the application reference number A006548093.

Please phone me on telephone number below during normal business hours if you have any queries regarding this matter.

Yours sincerely



Erik Christensen  
Urban Planner  
Planning Services North  
Phone: (07) 31782320  
Email: [Erik.Christensen@brisbane.qld.gov.au](mailto:Erik.Christensen@brisbane.qld.gov.au)  
Development Services  
Brisbane City Council

**Erik Christenson -“*The proposal must comply with the Brisbane Planning Scheme Codes, Brisbane Planning Scheme Policies and must be certified by a registered professional engineer of Queensland.*”**

21. Mr Christenson requires plans drawn by RPEQ and to demonstrate compliance with Council Codes and Planning Scheme policies.



*Dedicated to a better Brisbane*

Brisbane City Council ABN 72 002 765 795

**City Planning & Sustainability  
Development Services**

Brisbane Square, 266 George Street, Brisbane Qld 4000  
GPO Box 1434 Brisbane QLD 4001  
T 07 3403 8888  
[www.brisbane.qld.gov.au](http://www.brisbane.qld.gov.au)

19 December 2023

Avenue Capital Pty Ltd  
C/- Urban Strategies Pty Ltd  
PO Box 3368  
SOUTH BRISBANE QLD 4101

**ATTENTION:** Georgina McNee  
**Application Reference:** A006407802  
**Address of Site:** 15 BLACKWOOD RD GEEBUNG QLD 4034

Dear Georgina

**RE: Information request under the *Planning Act 2016***

Council has carried out an initial review of the above application and has identified that further information is required to fully assess the proposal.

**Stormwater code**

1. In accordance with PO11/AO11.2 and AO4.1 of the Stormwater code, the proposal must demonstrate the existing stormwater infrastructure proposed to be connected to Ellison St has sufficient capacity to receive the site's developed discharge and that no surcharge of the proposed pits within the site, or the existing manhole in Ellison Rd, will occur.

Provide:

a) An amended proposed stormwater layout shown on C5759-SK031 Rev E prepared by Milanovic Neale to show stormwater long section/s (showing the hydraulic grade line) and calculations.

2. The current stormwater plan only details the final arrangement when Stage 2 is implemented. Provide:

a) A stormwater plan showing the proposed stormwater arrangement for Stage 1 of the development.

3. It appears Lot 1 RP83676 (9 Blackwood Rd) is an upslope property and mapped contours indicate the lot falls to the south-west boundary of the development site. Connection through 349 Ellison Rd is not achievable as there is a natural sag at the rear of this site which falls to the development site. In accordance with AO11.1 of the Stormwater code, provide:

a) An upslope stormwater connection to Lot 1 RP83676.

4. Ensure any amended stormwater management plans/report addressing the above is signed/certified by a RPEQ.

**Earthworks - Filling and excavation code**

5. There is concern with the retaining wall on the western boundary, which must be offset from the boundary to ensure either the site accepts surface flows from the neighbouring site (as it does currently) and that no nuisance ponding is seen to the neighbouring property, or stormwater is directed to the rear properties (in accordance with PO5/AO5 of the Filling and excavation code).

a) Delineate the earthworks proposed for each stage. Provide a plan which details the earthworks proposed for Stage 1.

.../2



**Traffic/Access – Transport, access, parking and servicing (TAPS) code**

6. A minimum 2 metre x 2 metre single cord truncations to provide sufficient sight distances at the rear of the Common Property, as required by TAPS Planning Scheme Policy Section 4.12.1. In accordance with the TAPS code AO1, provide:
- a) Amended proposal plans to demonstrate truncations are provided at the rear of the proposed common property.
  - b) The proposed truncation at the frontage of the common property must also be dimensioned on the proposal plan to demonstrate minimum 2 metre x 2 metre single cord truncations.

**Private firefighting protection - Infrastructure design code P09, PO23 and PO24**

7. Fire protection coverage for the proposed new lot appears to exceed the maximum required 90m distance from building envelope to existing fire hydrant located on Blackwood Rd verge as required by Infrastructure Design Code PO9.
- a) Submit a firefighting coverage plan to demonstrate that any part of a future dwelling house resulting from this subdivision will be located no more than 90 metres from Urban Utilities (UU) fire hydrant or private fire hydrant.
    - i. Fire-fighting coverage measurement is to be from hydrant along the street to avoid obstructions, including fences, private property, and other buildings to the property entrance and around the perimeter of the future building or lot.
    - ii. If a new UU hydrant is proposed at the site frontage to achieve coverage, provide written acceptance from UU for this proposed new hydrant.

**Refuse - Infrastructure design code AO8.1**

8. It is noted on the proposed "preliminary services layout plan" prepared by Milanovic Neale (Drawing no. C5759-SK31, Rev E) that mobile garbage bins for all rear lots are to be presented on the frontage of proposed lot 5 for kerbside presentation. This does not comply with AO4(c) of the Subdivision code and AO8.1 of the Infrastructure design code. Sufficiently sized truncated areas must be provided either side of the internal access aisle (exclusive of crossover/crossover tapers) for the proposed Stage 2 lots 1-4 to ensure road frontage is available for each to facilitate compliant kerbside presentation.

Provide amended reconfiguration and civil plans that:

- a) Increases the size of the truncated areas on either side of the internal access aisle – a minimum width of 3.6m must be provided on either side (exclusive of crossover/crossover tapers) to facilitate two areas of 0.9m by 0.9m for each lot.
- b) Superimpose the bin presentation areas at the kerb for each lot's bins (0.9m by 0.9m per bin / two bins per lot) ensuring bins are presented on their respective frontage and not on the frontage of adjacent lots or on crossovers/crossover tapers.

**Urban Utilities (UU)**

Council does not undertake water and sewer assessment of any planning applications. Contact UU on (07) 3432 2200 to discuss any water and sewer issues and whether you are required to submit an application to UU for assessment.

**Responding to this request**

Your response should include a summary table which outlines any changes to performance outcomes and plans that have resulted from addressing the issues outlined above. The table should also include details of any supporting documentation.

If a response is not provided within the prescribed response period of three (3) months assessment of the application will continue from the day after the day on which the response period would have otherwise ended.

-2-

Email your response to [edanorth@brisbane.qld.gov.au](mailto:edanorth@brisbane.qld.gov.au) quoting the application reference number A006407802.

Please phone me on telephone number below during normal business hours if you have any queries regarding this matter.

Yours sincerely

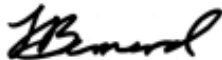

Jenny Bernard  
Urban Planner  
Planning Services North  
Phone: 0731780855  
Email: [Jenny.Bernard@brisbane.qld.gov.au](mailto:Jenny.Bernard@brisbane.qld.gov.au)  
Development Services  
Brisbane City Council

22. Another case above of a Council employee above, requesting an RPEQ for Upstream drainage design.

Jenny Benard is an excellent Council employee. She has demonstrated knowlegde That a concept upstream stormwater plan must be designed by an RPEQ engineer.

the development site. In accordance with AO11.1 of the Stormwater code, provide:

a) An upslope stormwater connection to Lot 1 RP83676.

4. Ensure any amended stormwater management plans/report addressing the above is signed/certified by a RPEQ.

***Jenny Barnard ...”provide an upslope stormwater connection to Lot RP83676. Ensure any amended stormwater management plans/report addressing the above is***

***signed/certified by a RPEQ.”***

The list is endless where excellent Council employees demand a standard of the RPEQ is to be certified by an RPEQ.

The individual employees for the subject case have not provided certification by an RPEQ.

22. According to the CCC, Brisbane City Council CEO should have been looking for any employees that have committed offences under S115(1) of the Professional Engineers Act.

23. The seven Council employees for 128 Ashridge Rd have drawn “markups” that

- do not demonstrate compliance with Council Codes and Planning Scheme policies
- are not drawn or signed off by RPEQ engineer.

**- will cause a fine of \$725,000 if any person designs or constructs contrary to their unlicensed allegedly criminal hydraulic plans.**

24. Only a licenced hydraulic person can draw plans, whether it be concept plans or “ready for construction” plans or “As constructed” plans.

This applies to all engineering licences whether it be plumbing, electrical or similar.

25. S164 of the Planning Act provides that no person can contravene the Development Permit.

**This means that the RPEQ engineer in the designs as required by S18 must comply with the DA permit to the millimetre of face a fine of 4,500 demerit points @\$160.30 = \$725,000.**

26. S84 of the Building Act provides that a certifier must not approve a development permit (BA) that will not comply with the earlier approval (DA). This situation will be triggered at the building of a structure and will cause a major problem since Council have designed the kerb adaptor 5.1m from the low side of the kerb, for no reason.

27. The action of the Council employees are to be deemed as an adverse finding by the Court to be referred to other bodies.

The following in pages 8-48 are mentionings and requests made by David Manteit, or by the DA applicant or by the Appellant in respect of Council employee RPEQ licence and engineering carried out under that licence.

- request for RPEQ licence
- request for engineering information of the approved hydraulic plans
- Statements by David Manteit and the Appellant of the repercussions of penalties to the Council employees for performing unlicensed engineering of the approved hydraulic plans.

**Council employees have been given 71 warnings/chances by David Manteit to provide the RPEQ licence.**

## Document 10 Notice of appeal

1.

### 10. Question of unlicensed hydraulic design.

A QBCC licence check reveals that the Council has no QBCC licence to to draw hydraulic plans.

An RPEQ search reveals that Ms Lucy Ting , Development Assesssment Officer is an RPEQ engineer,

An REPQ search reveals tha there is no evidence that Mr Tom Gibbs is an RPEQ engineer.

An audit by David Manteit of around 500 cases of approved reconfigure a lot cases decided by Brisbane City Council from 1/1/24 to 12/11/24 found that there was only one case in which Council designed a hydraulic plan.

The results of this audit are in another affidavit provided by Mr Manteit.

This Council prepared hydraulic plan "amended in red" is shown on the approved plan in the subject case.

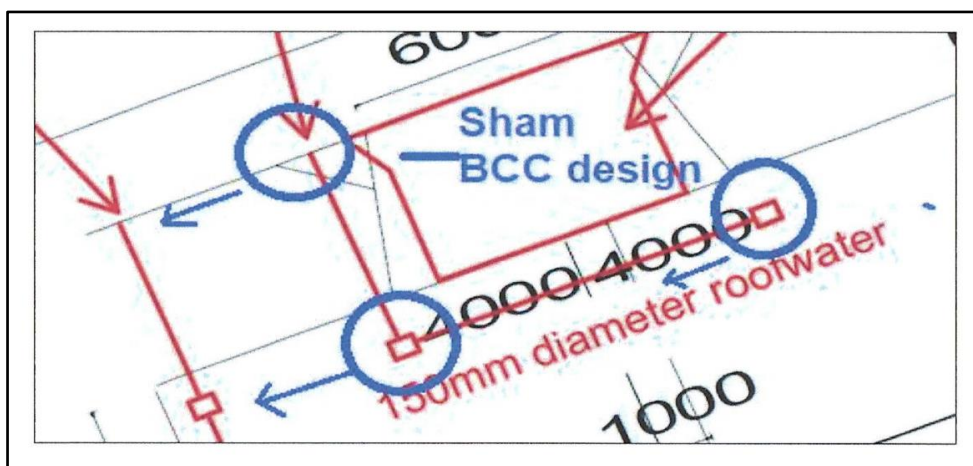

## 2.

This "amended in red" line and pits is evidence of poor design by Council in the above extract regarding internal roowater design.

The Council proposed location of internal pits some 4.9m and 4m from the right boundaries of the respective lots plus the location of the kerb crossing i4.9m from the right boundary indicate a lower than kindergarten ability to prepare hydraulic plans.

Identified -

No surface levels.

No invert levels.

Therefore no proof that the system works.

Just a red brushstroke like your kindergarten child brings home to you. If I was the author of the internal plan I would be ashamed to publicly produce this tripe.

Indeed, Council in the approved conditions requires the applicant to prepare plans prepared by a licenced hydraulic person or RPEQ, so one should not expect any less from Council when they prepare the only one plan in 500 reconfigure a lot cases this calendar year. All Council needed to do was get one and one case only, correct.

You either design properly or you don't design at all and If you do not design , you should make an information request to the applicant to design.

## 3.

10. Question of unlicenced hydraulic design.

A QBCC licence check reveals that the Council has no QBCC licence to to draw hydraulic plans.

An RPEQ search reveals that Ms Lucy Ting , Development Assessment Officer is an RPEQ engineer,

An REPQ search reveals tha there is no evidence that Mr Tom Gibbs is an RPEQ engineer.

An audit by David Manteit of around 500 cases of approved reconfigure a lot cases decided by Brisbane City Council from 1/1/24 to 12/11/24 found that there was only one case in which Council designed a hydraulic plan.

The results of this audit are in another affidavit provided by Mr Manteit.

This Council prepared hydraulic plan "amended in red" is shown on the approved plan in the subject case.

## 4.

**5. "Markups are indicitave only" and "Subject to further detailed design."** Council refuse to provide both the current design and the said further detailed design.

## 5.

Council has simply not bothered to do fill calculations, or alternatively have demonstrated incompetency.

One thing for sure is that Council refuses to explain their calculations to anyone.

It is my view that if one draws a red hydraulic line the author must be fully responsible for all liability and legal action against any defects in the design, including specific performance and damages in other courts.

Time is of the essence and it can cause great unnecessary holding costs and lost profits to the owner and therefore liability for damages against the author.

At the very least Council should have the decency to explain on the telephone some reasoning for the sham stormwater pipe. Council refuse to respond to all methods of enquiry.

There is no other known case of Council designing red stormwater lines. Especially when it is blatantly obvious that the red line is charged by at least .984 metres below the kerb, cannot work with 20,000 tonnes of fill, is non complaint with BSD 8111 and BSD 8113.

12. Council has designed the red line and is therefore the author of the red line and therefore has a legal requirement to supply all information on the design of the red line to the applicant.

## 6.

It makes no general sense to fill the subject site if the subject site is downslope of the rear properties. Council refuse to advise why the need for fill.

15. The site has an adopted usable pad minimum pad level of -

|                      |        |
|----------------------|--------|
| FSL at 6m setback    | 35.798 |
| FSL at 20.8m setback | 35.946 |

There is **not a teaspoon of dirt required to fill the site**, as requested in S12,17,18.

16. It appears that Council have purposely and mischievously tied up/connected lawful point of discharge for the Ashridge Rd lots with "The site must be filled".

The two principles are totally separate matters.

Council refuse to supply informations for same. Council have had 63 days to process the application with no information request or extension of time request made to the applicant.

7.

qbcc | QUEENSLAND BUILDING AND CONSTRUCTION COMMISSION

**Search for Licensee**

**Search Results:** Search - Main Page

No matching Licences found!

The requested licence [brisbane cit... (Builder / Trade Contractor)] has not been found.

- Please ensure you check the spelling of the name of the Licensee you are searching on.
- Please also be aware that some individuals may trade through a company structure. For peace of mind you should search companies as well.

Contact the Queensland Building and Construction Commission for more information.

[Add Filter](#)

Grid Graph Map 1 records « 1 - 100 » [Filters](#)

Q lucy ting

| _id  | RPEQ N... | Full Name    | Company     | Address 1 | Address 2 | Address 3 | City     | Stat |
|------|-----------|--------------|-------------|-----------|-----------|-----------|----------|------|
| 6535 | 14832     | Ms Lucy Ting | Brisbane... | 110       | Victoria  | Avenue    | BRISBANE | QLD  |

  
 .....  
 David Manteit - Appellant

END OF NOTICE TO APPEAL



# Document 11

## 8.

Page 4 of 48

In addition, the pits behind the boundary are totally in the wrong place.

If ever there was proof for incompetence, this is it. A licenced designer would have internal pits close to the boundary. This is aside from the kerb crossing argument. Only a novice pen pusher would place the internal pits 4.9m and 4m from a boundary.

The placing of the internal pit for Lot 1 should be in the driveway. It is not proper to have the internal roof water for the house to suddenly take a dog leg uphill. In addition, this interferes with the fall calculations and makes it more difficult to establish internal drainage fall. Thanks to Council for totally incompetent internal drainage system that only a non – licenced person would design that way.

The appellant has his applied his laser level from the ONF Surveyor's site height datum of 36.303 embedded in the angular part of the concrete kerb to arrive at AHD 35.1 for lawful point of discharge.

## 9.

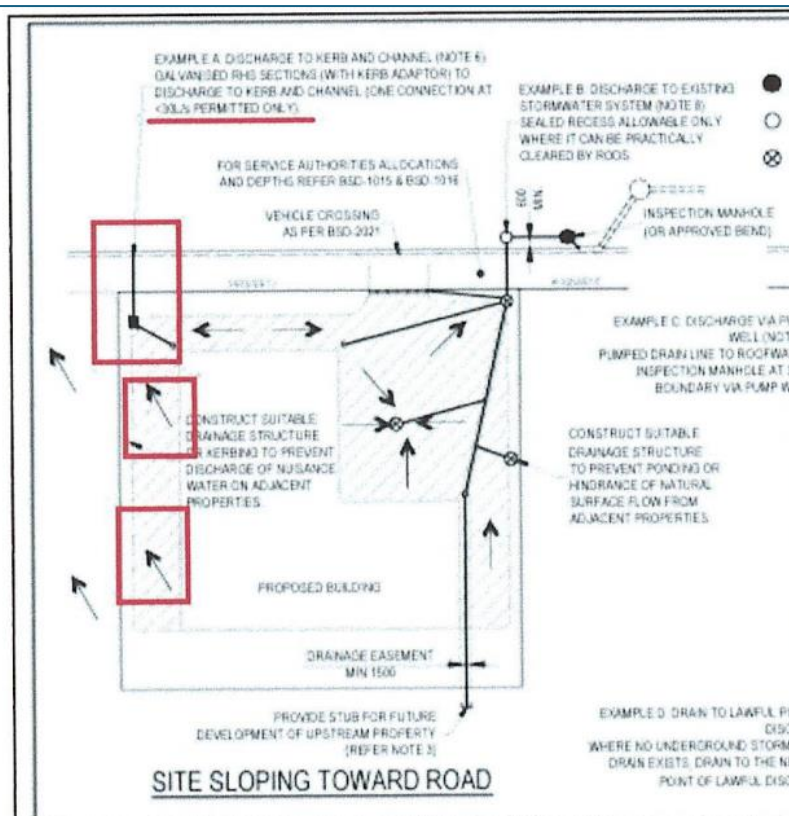

Above – BSD 8113 showing rough distance of 500mm from alignment with boundary at kerb for standard crossing.

## 10.

It is noted that the maximum kerb adaptor velocity will be for 30 l/s, which will accommodate 2 lots.

## 11.

### Connection to kerb and channel

#### 7.6.3.1 Connection to kerb and channel

- (1) The maximum permissible discharge to the kerb and channel must be limited to 30L/s (i.e. maximum 2 single house lots per discharge point dependent on roof area), and twin 100mm diameter pipes (equivalent 150mm diameter) with approved kerb adaptors.
- (2) For development that is a material change of use (i.e. other than (1) above), Level III drainage (connection to kerb and channel) is only permitted if the total discharge from the development including any external catchment does not exceed 30L/s. Multiple hot dip galvanised rectangular hollow sections (RHS) 125/150/200mm wide x 75mm or 100mm high must be used (refer to [BSD-8113](#)).
- (3) Only approved full-height kerb adaptors, complying with [BSD-8114](#) are permitted. The kerb adaptors must be placed in a location where service pits on the footpath will not conflict with the future pipe location.
- (4) Discharge into the high side kerb of a one-way crossfall street is generally not permitted for any development other than a single-house dwelling.

**7.6.3.1 Connection to kerb and channel provides for 2 single house lots per discharge point.**

## 12.

### NOTES:

1. DESIGN FLOWS CALCULATED BASED ON MANNING'S 'n' OF 0.011. PIPE SIZED ASSUMING A DISCHARGE OF 15 L/s FROM EACH ALLOTMENT - BASED ON ROOF AREAS OF 250m<sup>2</sup> AND ARI OF 20 YEARS FOR S.E. QUEENSLAND. ALL PIPES SHALL HAVE A MINIMUM DIAMETER OF 150mm, EXCEPT ACROSS FOOTPATH.
2. WHERE THE PIPE GRADIENT EXCEEDS 5%, UNDERTAKE A MORE DETAILED HYDRAULIC ANALYSIS INCLUDING THE ASSESSMENT OF STRUCTURE LOSSES, WHERE APPROPRIATE.
3. AN EASEMENT IN FAVOUR OF COUNCIL IS REQUIRED WHEN THE ROOFWATER LINE IS DESIGNED TO SERVICE MORE THAN 2 ALLOTMENTS, IRRESPECTIVE OF PIPE SIZE.
4. DISCHARGE TO KERB AND CHANNEL MUST BE LIMITED TO 30L/s.
5. PROVIDE MINIMUM 450 COVER TO PIPES EXCEPT WHERE REDUCED COVER IS NECESSARY TO EFFECT DISCHARGE TO KERB AND CHANNEL. PIPE TYPES AND CLASSES TO COMPLY WITH THE FOLLOWING REQUIREMENTS:
  - UPVC PIPE (MINIMUM SEWER CLASS SN8) MANUFACTURED IN ACCORDANCE WITH AS1260;

**Above – Extract from BSD 8111, showing 450 cover.**

# 13.

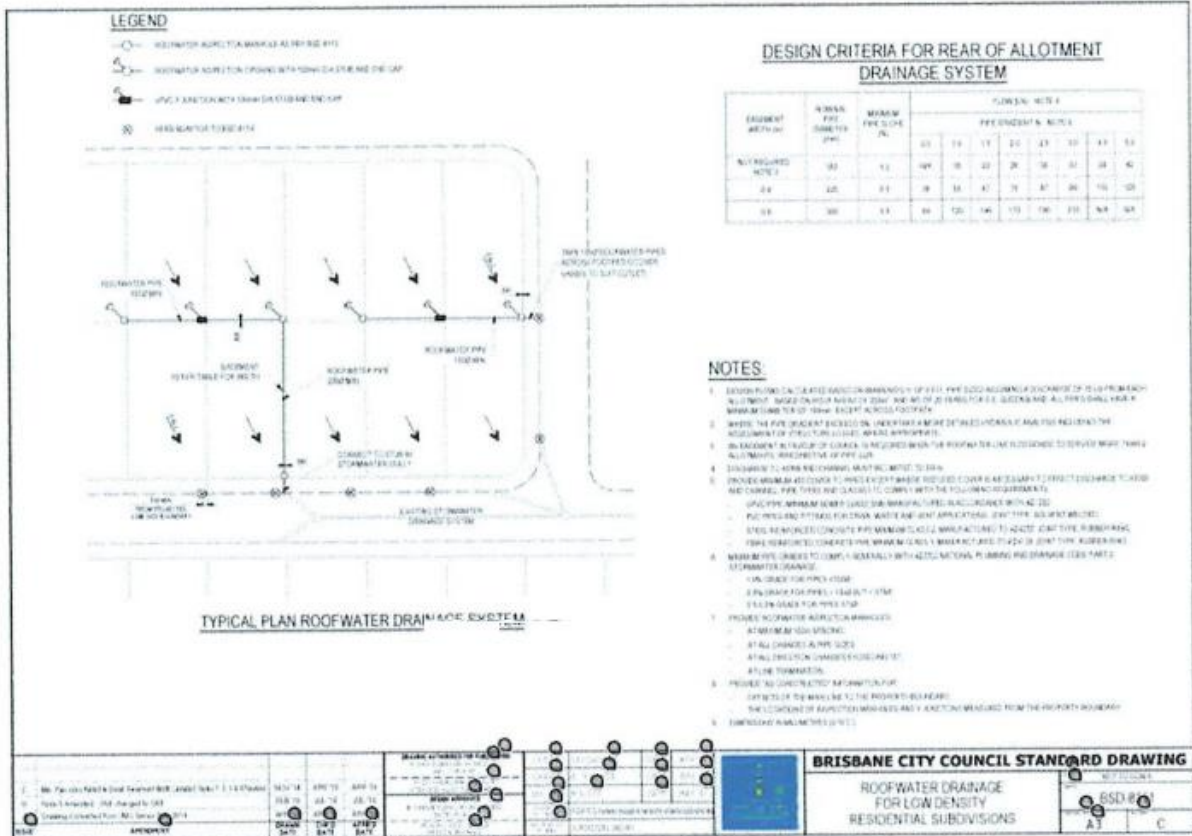

Above BSD 8111 full copy.

# Document 12

# 14.

2. Council is responsible for their own plans, in the same way. Council is responsible for their own plans, ie red line stormwater plan, "Markups Only" and "Further detailed design required"

## 15.

**6. Council is author of plans.** In relation to all previous developments and construction I have always built to plans and engineering specifications. Council is the author of -

- requirement of fill in S12, S17, S18.
- requirement of stormwater red line
- requirement to change driveway flanges.

Council state that the stormwater line is a "markup only" and "requires further detail design". Council has a responsibility to provide engineering detail and answer questions

It is unfathomable why Council would clearly state that basically they have no engineering or proof of their red line.

If Council has proof of red line engineering, Council should supply it to me.

If Council has no engineering proof of red line, Council should remove red line and conditions.

## Document 13

## 16.

10. The case of 124 Ashridge Rd Darra is the only case of 500 cases that Council has -

- designed stormwater pipes and placed a red line on the approved plan with pits, kerb crissing and locations and kerb adaptors.

- designed fill three times for the site for Lawful Point of Discharge and Upstream properties.

In my view, these persons are personally responsible for my holding costs and specific performance If their calculations are incorrect.

11. These persons had the chance to make an information request to David Manteit after the Property made date of 23/7/24 to avoid any legal obligation or damages to David Manteit but they chose not to, Hence these persons are personally responsible for -

- specific performance
- holding costs
- damages
- loss of profits.

17.

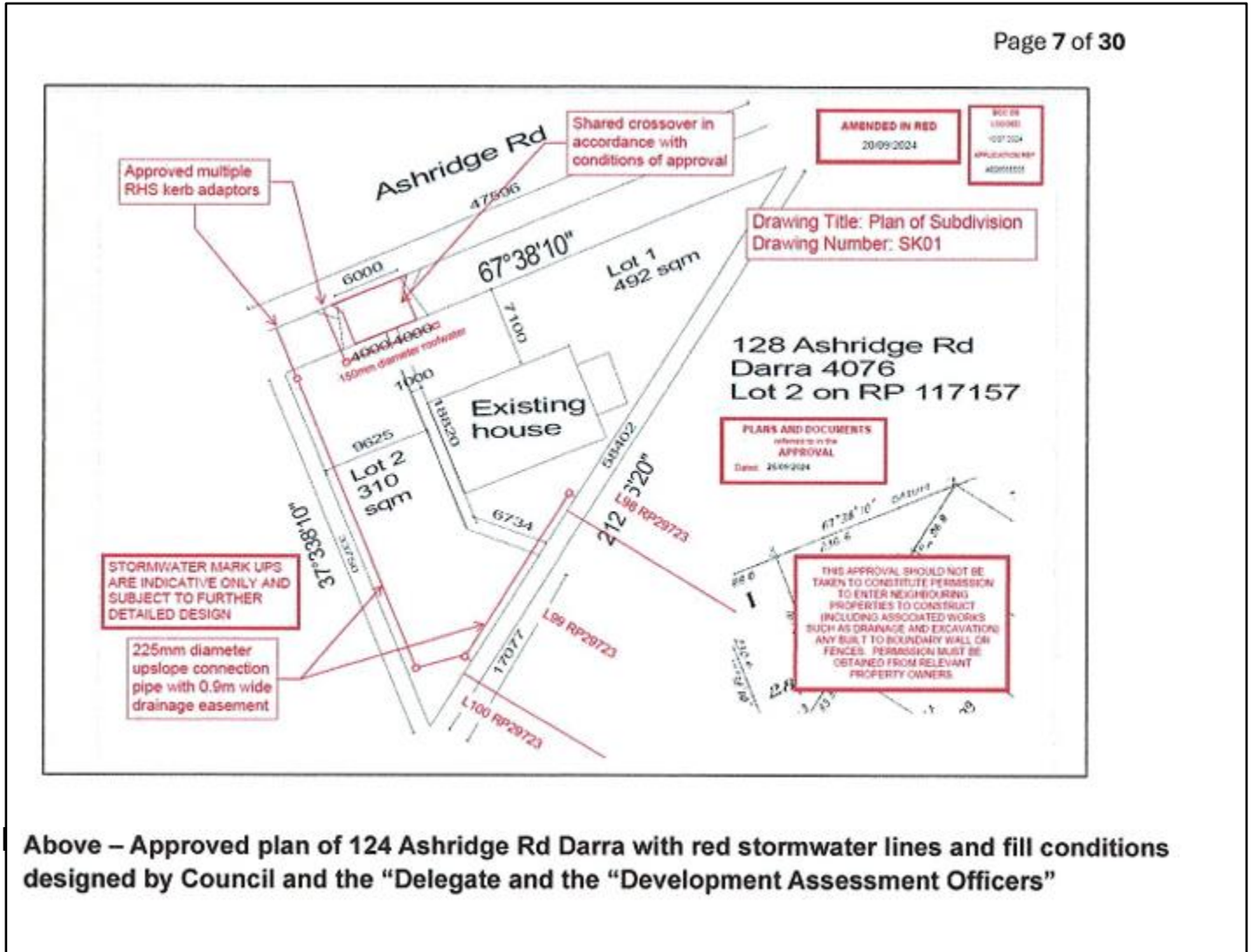

Above – Approved plan of 124 Ashridge Rd Darra with red stormwater lines and fill conditions designed by Council and the “Delegate and the “Development Assessment Officers”

## 18.

In addition, the following is required –

Surface levels and invert levels of the pits. Cover, pipe diameter.

Compliance of construction with Council's BSD 8111.

Easement document as per S7 of approval and the constraints of S 7.4.7 above.

Crosssection of proposed trench

Build over sewer consent.

Vibration and compaction details.

## 19.

The Council designed the red line. The Council is therefore responsible for the damages of the applicant should the red line not being able to be constructed. A separate legal notice has been issued today for separate court action. That notice will no doubt be ignored as past warnings have not been acknowledged. That is Council's policy, as per Sara McCabe advices.

Please ensure that Council addresses all items underlined above.

The Stormwater line cannot be built as per Council's own guidelines.

Council refuses to supply a copy of the **Easement document**, which is a requirement of 7.4.7.

I await your advices by Wednesday 13-11-24 .

## 20.

Certainly, for quick cross check, all of the attached approved plans in the affidavit re upslope stormwatre have no internal Council design for the front lots. Some of the 500 cases may have another way to lawful point of discharge. In fact, in 82 Rowe Tce Darra , my own case, I put a 150 saddle on a 1200 Council pipe in the neighbour's yard. All designed by me and the RPEQ.

I have some questions before finalisation of my complaint to the Professional Board of Queensland Engineers tomorrow. They have the same questions as me.

Your responses may affect the orders sought for this case an upcoming case in other jurisdictions.

21.



BOARD OF  
**PROFESSIONAL  
ENGINEERS**  
OF QUEENSLAND

ABN 85 257 425 108  
07 3210 3100 admin@bpeq.qld.gov.au  
Level 6, 288 Edward Street BRISBANE Qld 4000  
GPO Box 5216, BRISBANE Qld 4000

## COMPLAINTS AGAINST REGISTERED PROFESSIONAL ENGINEER (FORM 6)

Section 37 – *Professional Engineers Act 2002 (Act)*  
Approved 23 July 2021  
Version 3 (July 2021)

### GUIDANCE

Please complete the following information. For guidance in completing this form, please refer to the *Complaint Information Sheet*. If further assistance is required please contact the Board of Professional Engineers of Queensland (**Board**).

On completion, please forward this Complaint Form together with any documentation required to:

**The Registrar**  
Board of Professional Engineers of Queensland  
GPO Box 5216  
BRISBANE Qld 4000

or

### Questions –

1) Is Ms Lucy Ting the person who authored the red line, 2 pits and kerb crossing for 124 Ashridge Rd Darra approved plan?

Or did someone else draw this plan?

2) Why, specifically is this the only time in 500 subdivision cases this year that Council decided to design draw a sham red line system when there is no other red line Council system this calendar year ?

3) Why, specifically did Council decide for the first time in 500 cases, to design and –

Make the kerb crossing 4.9m from the right boundary, ie, smack in the middle of Lot 2 kerb, up from the normal 500mm from the boundary and be non-complaint with BSD 8113 ?

Make the two pits behind the boundary 4.9m up from the right side for Lot 2, and 4m up the kerb for Lot 1 ?

As mentioned in affidavits, this could cost me \$172,000 in additional costs.

4) Is Council and the author aware that they are responsible Individually or the losses incurred as a result

## 22.

6) Does the person who draw the red lines,etc have a licence to draw plans as a plan preparer, with QBCC ? Is it Lucy Ting ? Does Tom Gibbs hold an RPEQ membership ?

| _id  | RPEQ N... | Full Name    | Company     | Address 1 | Address 2 | Address 3 | City     | Stat |
|------|-----------|--------------|-------------|-----------|-----------|-----------|----------|------|
| 6535 | 14832     | Ms Lucy Ting | Brisbane... | 110       | Victoria  | Avenue    | BRISBANE | QLD  |

Incidentally it is my recollection that the the advice from his honour Judge Willaimson KC on 15/11/24 was that he strongly recommeded the author of all red lines on the approved plan to attend the ADR conference.

But the earlier you respond or do not respond, the earlier this Court and the Professional Board of Engineers can provide advice as to –

7) Has the author of the red lines etc intentionally wiped out the two notes being “4000” twice for the driveway ? Is this intentional ? Do the 4000 notes remain ?

Or did you kill two birds with one stone – design a sham stormwater system and wipe out driveway



23.

2/1/24, 8:54 PM Mail - david manteit - Outlook 22/11/24

---

 Outlook

---

**POTENTIAL CRIMINAL ACTS UNDER S 15 OF THE PE ACT . DAVID MANTEIT V BRISBANE CITY COUNCIL2916/24**

---

**From** david manteit <davidmanteit@hotmail.com>  
**Date** Fri 22/11/2024 10:16 AM  
**To** Sarah McCabe <sarah.mccabe2@brisbane.qld.gov.au>  
**Cc** Margaret Orr <Margaret.Orr@brisbane.qld.gov.au>; tom.gibbs@brisbane.qld.gov.au <tom.gibbs@brisbane.qld.gov.au>; lucy.ting@brisbane.qld.gov.au <lucy.ting@brisbane.qld.gov.au>; Joel Wake <joel.wake@brisbane.qld.gov.au>; Zarndra Piper <zarndra.piper@brisbane.qld.gov.au>; Scott Ruhland <scott.ruhland@brisbane.qld.gov.au>; CPAS-DS-PlanningSupport <DSPlanningSupport@brisbane.qld.gov.au>; CityLegal <city.legal@brisbane.qld.gov.au>; ccu@justice.qld.gov.au <ccu@justice.qld.gov.au>

DAVID MANTEIT V BRISBANE CITY COUNCIL 2916/24 CORRESPONDENCE

Dear Ms McCabe.

Further to my letter yesterday it appears that Council and Development Services Team employees have committed an offence by providing unregistered engineering services, since you refuse to provide any licencing details.

**This carries Potential Criminal Responsibility for Council plus those employees.**

**Council and/or Development Services Team members have provided engineering services by placing red lines and pits on the approved plan of 124 Ashridge Rd Darra.**

**See extract below of Board of Professional Engineers of Queensland.**

24.

10

12/1/24, 8:54 PM Mail - david.manteit - Outlook



During BPEQ's seminars and meetings with local government several questions have been asked about the relevance of the *Professional Engineers Act 2002 (PE Act)* for organisations.

The PE Act requires that individuals who carry out professional engineering services must either be a registered professional engineer of Queensland (RPEQ) or be directly supervised by a RPEQ. However, the PE Act also applies to corporations and their officers (e.g. directors), managers and other persons who procure or direct persons to carry out professional engineering services.

**Potential Criminal Responsibility**

It is an offence under section 115 of the PE Act<sup>1</sup> for a person to carry out "professional engineering services" if the person is not a RPEQ not directly supervised by a RPEQ (unless the professional engineering service is carried out only in accordance with a "prescriptive standard"<sup>2</sup>). At law, a "person" includes a corporation. This means that a corporation can also be found guilty of this offence where a court finds the corporation criminally responsible for the unregistered person/s carrying out professional engineering services.

Similarly, the Criminal Code of Queensland provides that another person can be found guilty of this offence where they aid, counsel or procure<sup>3</sup> a person to commit that offence or where they have "common purpose" with another person to commit that offence<sup>4</sup>. These provisions in the Criminal Code are sometimes referred to as the "extensions of criminal responsibility".

For this reason, corporations, corporate officers and managers who have persons in their corporation or team who carry out professional engineering services should be aware of the requirements of the PE Act and the offence provision in section 115 of the PE Act.

If the Development Services Team have provided services, lawfully, they will be a party to further damages proceedings in other jurisdictions.

If the Development Services Team have provided engineering services unlawfully, Council and the Development Services team members may be prosecuted, plus damages proceedings in other jurisdictions.

Please advise your position by 5pm today so that I may consider further actions as necessary.

Yours Faithfully

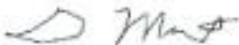

**David Manteit**  
CEO  
0424 739 923  
[howtowineveryday.com.au](http://howtowineveryday.com.au)

<https://outlook.live.com/mail/w/0/AQMkADAwATEwYjE4LTdkMDQ1YWEAZjczMDACLTAwCgBQAAADsEh3CeyMuEONhv1fQjLHgoAbXG%2FIBS2TU...> 2/3

## 25.

3. I now require Council to provide a Form 15 for their engineering design of -

Upslope stormwater line, 4 pits and one kerb crossing

Internal stormwater line, 2 pits and one kerb crossing

Earthworks to Fill the site as required 3 times in the approval, S12,17,18.

## 26.

12/1/24, 8:53 PM

Mail - david manteit - Outlook

Remember, this engineering design by Council is the only engineering design to my knowledge by Council In 500 reconfigure a lot, code assessable cases decided from 1/1/24 to 12/11/24 as per previous audit report and affidavit supplied by David Manteit to Council.

4. **Please supply the names** of the persons that authored the Council hydraulic design and earthworks design.

5, **Were these authors unlicenced ?** Were the authors supervised by the licenced author? Has Council or Development Services Team members due for 1000 penalty points?

### PROFESSIONAL ENGINEERS ACT 2002 - SECT 115

#### Who may carry out professional engineering services

#### 115 Who may carry out professional engineering services

(1) A person who is not a practising professional engineer must not carry out professional engineering services.

*Penalty—*

Maximum penalty—1000 penalty units.

(2) However, a person does not commit an offence under *subsection (1)* if the person carries out the professional engineering services under the direct supervision of a practising professional engineer who is responsible for the services.

(3) A person who is a practising professional engineer must not carry out professional engineering services in an area of engineering other than an area of engineering for which the person is registered under this Act.

*Penalty—*

Maximum penalty—1000 penalty units.

(4) However, a person does not commit an offence under *subsection (3)* if the person carries out the professional engineering services under the direct supervision of a practising professional engineer who is registered in the area of engineering and responsible for the services.

(5) For this section, a person carries out professional engineering services under the direct supervision of a practising professional engineer only if the engineer directs the person in the carrying out of the services and oversees and evaluates the carrying out of the services by the person.

I require your response to these items by Tuesday 26-11-24.

6. I advise that a complaint was made to the Board of Professional Engineers Queensland yesterday as promised.

## Document 15

**27.**

**Easement document.**

1) Please provide proposed surface levels and invert levels of the 225mm stormwater pipe.  
about:blank

**28.**

If you refuse to respond to these questions on "YOUR DESIGNED RED LINE" then I encourage the court to consider this action and to take into account any costs of the case.

**29.**

2) Please provide **cover distance above, below, left and right** of the 225 stormwater pipe. Note any requirements below that may affect this cover d distance.

30.

**Today's phone call.**

Today, I requested by telephone to the receptionist to talk to the City Legal Team.

I have not had a response by that legal team. Please get them to resopnd by 10am tomorrow, 2/10/24.

A person who identified himself as Joel Wake. I did not call him. He called me.

I asked him several questions -

Please provide the easement document wording proposed. He said "thats down the track"  
I said "no, it's now. I need to assess BCC red line now"

What part of a retaining wall can be in the easement.? Existing and future ?  
What part of a retaining wall footings can be in the easement.? Existing and future ?

Does he know the surface and invert levels proposed by BCC ?

What type of surface is the easement proposed to be by the BCC ?

Can services be placed in the easement?

Have you checked the easement pipe for falls ?

Wake said he didn't know that answer to any of my questions.

I said "Surely, you state that you are the assessment manager. but you have no knowledge of these items?"

I asked Wake if he assessed the stormwater pipe. He said no. He said "You should contact them. They will tell you"

I asked "Who are they ?"

He said "They are listed on the approval package"

I asked "what are their names, they are not called They"

Wake did not know their names.

I asked Wake "who is the assessment manager for Planning Act purposes? " He said "I am the assessment manager"

I said "there is no written document showing you as the assessment manager, or anyone else" Wake said "It's on the letter I sent you 26-9-124" Joel has lied here, yet again, since there is no reference to an Assessment Manager in that letter. See below.

Wake said "I am wasting his time in this phone call."

I said "You called me, I didn't call you. Whilst you are on the phone, can you please answer some questions?"

It may be wasting your time, but it's imprtant to me, and it's not wasting my time. Your time is being wasted"

I asked Wake again "Have you assessed the stormwater pipe if you are the assessment manager?"

He said "No, other people have assessed it, not me"

"I have no idea"

Regards

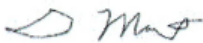

**David Manteit**

## 31.

4. Please advise if you disagree with the above statements highlighted in yellow..
5. Please provide BCC surface and invert levels of BCC proposed stormwater red line plan for supposed upslope rear lots used in the assessment of the red line.

## 32.

### **“Provision of a stormwater drainage connection for upslope properties.”**

I have attached plan view and crosssection to demonstrate that the red line shown of the approved plan is charged.

The red line is charged by .907 m using BSD 8111 requirements of 225mm pipe, 450 cover and .5% degree fall, but using illegal sham triangular line which is not within 600 mm of the boundary

The red line is charged by .984 m using BSD 8111 requirements of 225mm pipe, 450 cover and .5% degree by using legal method of keeping line within 600mm of the boundary.

The red line is charged by 1.269m by using conservative 225mm pipe, 450 cover and 1% degree fall.

4. Please advise if you disagree with the above statements highlighted in yellow..

## 33.

**6. Can Council please provide a list of what BCC tests was used to determine if they of the rear properties are an “Upslope” property.**

In the absrence of a definition of “Upslope”, one must take into account or apply the following tests -

A Council BSD 8111 design drawings mentionings of upslope, arrows.

## 34.

C The subject property falls to the rear properties. The site 134 Ashridge Rd Darra falls from the rear properties at the boundary, to the subject property but still didn't require rear property stormwater provision by BCC.

D The subject property cannot provide a stormwater design to the rear properties that is not charged. The property 134 Ashridge Rd cannot design a Stormwater design that is not charged. From this point of view, the sites are the same.

**9. How is the applicant able to construct a BCC designed charged line? Can BCC show BCMT how this is done ? I called them today to ask Margaret Orr to explain how to construct the pipe.**

**10. Will BCMT be able to inpect a stormwater end of line at the kerb that is .907mm, .984 mm, 12.49 mm below the kerb?**

**11. Will BCMT sign off on the inspection of the kerb at the construction phaset that is a sham design?**

## 35.

In addition, I provide as assessment below of the overall fall from front to rear.



As can be seen from this analysis, any fool can see that normal surface water cannot travel from any part of the rear to the front.

12. Can Council please explain how the rear proerties are “Upslope Properties” under this test ?

## 36.

Can BCC RPEQ please provide their crosssections used to determine legal point of discharge ?

This includes crosssection at the stub location of Lots 98 and 99 to demonstrate they are not proposing a Roman Aquaduct system as above.

“Stormwater mark ups are indicative only”

“Stormwater mark ups are indicative only and subject to further detailed design.”

**STORMWATER MARK UPS  
ARE INDICATIVE ONLY AND  
SUBJECT TO FURTHER  
DETAILED DESIGN**



## 37.

Joel Wake of no specific title said in a phone call to myself when he called me on 1/10/24 that he had not personally assessed the stormwater requirements for the site.

**23. Please advise why Joel Wake of multiple titles refused to assess stormwater requirements in the assessment process.**

**24. Please advise why Joel Wake of multiple titles refused to discuss stormwater matters other than in a telephone conversation “have you got a hydraulic consultant ?**

Joel Wake with various BCC titles, except Assessment Manager under the Planning Act, was offered by myself in a phone call to myself on or around 15/8/24 a chance to inspect my site from the ground plus first floor view from the lounge room. I also offered him tree use of my laser level. Wake refused this offer.

**24. Please advise why Joel Wake of multiple titles did not accept my offer to inspect the subject site.**

**I require your responses by 5pm Thursday 10/10/24.**

**Yours Faithfully**

# Document 19

## 38.

### Chapter 7 Stormwater drainage.

I require the Council to provide explanation of how the Council requirements of S 7.4.7 Building near or over underground stormwater infrastructure below can be satisfied in the Council drawn and designed red line of approval of 128 Ashridge Rd Darra by Wednesday 5pm 13-11-24.

The said line is approximately 55 metres long with 5 pits and multiple kerb adaptors.

This line has been designed by Council and not David Manteit. Therefore the Council has responsibility to provide this information to David Manteit forthwith.

This information has already been requested by David Manteit many times, but refused to supply.

In addition, the following is required –

Surface levels and invert levels of the pits. Cover, pipe diameter.

Compliance of construction with Council's BSD 8111.

## 39.

**Summary of the findings are** (and also pertaining to 128 Ashridge Rd Darra) –

1) There is ample evidence of Development Services Team (DST), Council staff for A006565555 have performed engineering and committed offences under -

Schedule 2 and S115 of the Professional Engineers Act 2002.

S 15 (1) of the Crime and Conduct Act 2001.

The evidence of unsatisfactory professional conduct, of a registered professional engineer, (including unregistered and unsupervised ) is not only littered throughout my report of 20-1-25 but in virtually every item of correspondence sent to Council staff (DST Team) prior to Court applications dates and in affidavits lodged with the Planning and Environment Court. (And the refusal of Council staff to provide engineering information.)

The CCC gave certain Councils a wake up call/warning in December 2020 to stop local government performing engineering, which is unlicensed, which is therefore classed as "corrupt conduct".

This information/factsheet by CCC is relevant for this Planning Court Case, and is basically a cookie cutter for assesment of this case.

This fact sheet is currently online on the CCC website for the world to see. "This factsheet explains when the

## 40.

### Disaster – 128 Ashridge Rd Darra

Abundance of evidence of alleged offences by Council Development Services Team staff member unsatisfactory professional conduct, from a registered professional engineer, and grounds for offences of unlicensed performance by Council staff of engineering of Stormwater, Fill, and driveway of 128 Ashridge Rd Darra, which has now caused damages actions in other Courts.

A summary of the unsatisfactory professional conduct -

#### **128 Ashridge Rd Darra approval documents.**

There is a complete engineering design by drawing of Upstream and Onsite Drainage, being 6 red stormwater lines (pipes), (70 metres), pits (6), and kerb crossings (2), except the following -

- (a) missing engineering and
- (b) non-compliant/non- conforming/unlawful engineering design .

#### **Missing**

- No surface or invert levels of 6 pits and 6 pipes provided in the engineering, as amended on the plan.

## 41.

- **Upstream Drainage** - Council staff (DST) engineered system does not comply with “That part of the lot that would drain through the Development” required under Planning Scheme Policy S 7.6.5. Non-compliant. This Council staff (DST) engineered system is charged by around 1 metre at the kerb. Non-compliant with Planning Scheme Policy S 7.6.5 and BSD 8111, 8112, 8113, 8114. Unsatisfactory professional conduct of a registered engineer, Shedule 2 and S115 of the Profesional Engineers Act 2002.
- **Onsite Drainage** - Drawing of kerb adaptor to the Council staff (DST) engineered Onsite Drainage being 5.1 metres (instead of 500mm) further up from the lowest part of the kerb, being non-compliant with BSD 8111. Costing the applicant over \$172,000 in extra costs and damages. Unsatisfactory professional conduct of a registered engineer, Shedule 2 and S115 of the Profesional Engineers Act 2002.

## 42.

- Drawing of Council staff (DST) engineered **Onsite Drainage** 2 pits, 4 metres away from lot boundaries being non-compliant with S7.2.3 and BSD 8111. Unsatisfactory professional conduct of a registered engineer, Schedule 2 and S115 of the Professional Engineers Act 2002.
- Drawing of “150” pipe for engineering of **Onsite Drainage** being exact and not “minimum 150”, being non-compliant with wording of S7.2.3, Table S7.2.3A, S7.6.3.1 and BSD 8111. Unsatisfactory professional conduct of a registered engineer, Schedule 2 and S115 of the Professional Engineers Act 2002.

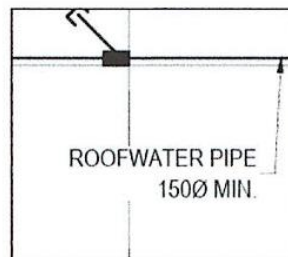
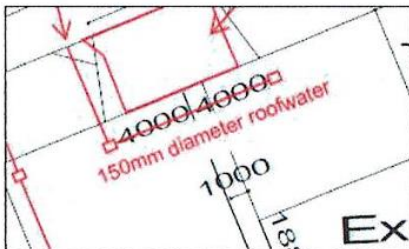

- Issuing of **Fill conditions in S12,17,18**, being a Council staff (DST) engineered fill system that are non-compliant with Stormwater Code, Brisbane Planning Scheme Policies S7.2.3, S7.6.5, S7.6.3.1, and BSD 8111, due to no detail provided and fill not being required for lawful point of discharge. Unsatisfactory professional conduct of a registered engineer, Schedule 2 and S115 of the Professional Engineers Act 2002.
- Conflict between Conditions 12 17 18 “Fill the site” and note on plan “Retaining walls must be

## 43.

### **S84 Building Act 1975.**

It is mentioned here that should Council staff decide to performing engineering by themselves, totally of their free will, or being forced, instead of issuing an information request, the following happens -

## 44.

- A Private Cerifier is unable to approve a Bulding Development Permit (BA) that is inconsistent with an earlier approval. (Town Planning Development Approval/Development Permit)

- Council and Council staff run the risk of damages cases from all current and future owners of the approved site of Council staff unsatisfactory professional or unclear engineering or missing engineering information.

- There are huge fines from Council for any person performing building work (including RPEQ engineering design) that is outside the approved Development approval.

Therefore the owner or owner RPEQ cannot design or build anything that is not strictly in accordance with the DA approval.

In the case of 128 Ashridge Rd Darra, the owner or owner RPEQ cannot design anything that is one millimetre different from the approved red lines and conditions.

Council staff refuse to advise the owner, David Manteit as to what are the surface levels and invert levels of pipes and pits. This is unsatisfactory professional conduct.

## 45.

The Council approval is forcing the applicant RPEQ or QBCC licensee to finalise an unlawful/illegal Council engineering design.

It's like the Council planned the robbery and now they want some lackey to do the actual robbery, while they hide back at home.

The hydraulic designer/engineer is stuck with the Council sham triangle, the red line in plan view, 225mm pipe exactly, and no surface levels or invert levels for Upstream drainage, as a minimum.

The designer is stuck with the 5.1 m away from the right boundary kerb adaptor as a minimum. Plus the 150 exact pipe for Onsite Drainage, as a minimum.

Council cannot force the applicant RPEQ to commit an unlawful act. This is an offence by Council. This is the type of thing that the Crime and Corruption Commission look for.

## 46.

Note in the approval of 128 Ashridge Rd Darra, S17 and S18 it is stated that the design by the owner must

engineer and supply drawings “generally **as shown** on the amended plan in red”. Not left, not right, of the red line.

The specific requirement is to design and construct “as shown”. Not drawn nilly willy, all over the place, anywhere you like.

Therefore this condition is **not the same as a standard Upstream condition**, where an RPEQ has more freedom to design, (but notwithstanding he has to design within Council Laws.)

**Council staff for this case have forced/are forcing owners, RPEQ’s and contractors to commit an offence by finalising designing a non-compliant Council staff DST engineering design.**

There are unlawful engineering designs in Council engineering of 128 Ashridge Rd Darra, Example, sham triangle design of Upstream pipes.

## 47.

### **Conduct of Council licenced or unlicenced engineers**

Council refuse to supply engineering information of Council staff (DST) engineering to the owner, David Manteit.

City Legal refuse to supply site specific easement engineering information of their easement design to the owner, David Manteit

The CCC, as advised in the 2020 brochure, look firstly to see whether there has been an offence.

## 48.

Page 26 of 36

To date, Council refuses to provide engineering information to David Manteit. The communication aspect or lack thereof, is in my opinion, misconduct, and penalties should apply. The same thing will happen in the future to each and every owner of this property.

A problem is, that when Council perform engineering design that is incomplete, wrong, or does not comply with Council's own engineering laws, an owner is forced to make a S81 minor change.

A major problem is that nobody know what the surface levels and invert levels are. So what exactly needs to be changed ? Nobody knows. Council staff are hiding, and this is therefore engineering misconduct under S115 of the Professional Engineers Act.

Because of the massive blunders by the Assessment Team this may not be considered a minor change, and may be a major change, and then a Court Case ensues, costing the owner hundreds of thousands of dollars. All because of Council's unsatisfactory professional conduct, of a Professional Engineer as per Schedule 2 and S115 of RPEQ Act 2002.

The above aspects of misconduct may carry through to a S 15 (1) of the CCC for corruption.

### **Planning and Environment Court conduct.**

His Honour Judge Williamson, KC, in the Planning and Environemt Court in November issued a verbal request to Council's Counsel for the author of the red stormwater lines to be present at an ADR conference between the parties, in December 2024. Council's Counsel disobeyed that request.

## 49.

### **Refusal by Council staff to provide engineering detail**

Despite numerous questions to Council and Development Assessment Team members, they refuse to provide engineering information and the names of the licenced and unlicenced engineers who performed the engineering.

I believe this is unsatisfactory conduct, by a Registered Profesional Engineer, as per Schedule 2 and S 115 of the Professional Engineers Act 2002.

Anyone who performs Engineering has an obligation to provide reasons for unlawful and incomplete engineering. There is no other case in 412 cases in that Council has comprehensively performed engineering services.

### **Board of Registered Engineers Queensland Engineering Code of Practice**

**It is alleged that Council DST staff have contravened the Engineers Code of Practice.**

# 50.

## PRINCIPLE 1.2

### Registered professional engineers work within the limits of their professional expertise

A registered professional engineer must:

- undertake professional engineering services only within their area of registration and competence
- only undertake direct supervision within their area of registration and competence
- in the course of their professional practice, be honest and accurate regarding qualifications and experience and not make any statements or publish any material that may, or does, mislead a client or prospective client as to their professional competence
- recognise where other professional advice is required and either seek it or recommend to an employer and/or client to seek such expert advice in appropriate areas
- act with an appropriate level of due diligence in the provision of professional engineering services.



# 51.

## PRINCIPLE 1.3

Registered professional engineers treat all their stakeholders with courtesy and dignity

A registered professional engineer in the conduct of their professional practice must:

- promote confidence in, and respect for, the engineering profession and not act in a way that brings the profession into disrepute
- act in a way that maintains the standards and integrity of the engineering profession
- in all their professional dealings enhance the reputation of the engineering profession.

## 52.

### PRINCIPLE 2.1

Registered professional engineers are positive role models within the profession and in the community in general

A registered professional engineer must:

- demonstrate integrity and act appropriately in all circumstances
- by their conduct, endeavour to improve the diversity, equity and inclusion of the engineering profession
- by their conduct, endeavour to engender confidence in, and respect for the engineering profession and not act in a way that brings either them or the profession into disrepute
- by their conduct, exemplify high standards and integrity of the engineering profession
- take responsibility, whenever and wherever possible, to contribute to the quality and sustainability of the natural and built environment.

In the provision of services, a registered professional engineer must take into account:

- the public interest
- the natural environment whilst striving to improve the built environment
- the conservation of Australia's heritage
- the conservation of natural resources.

## 53.

### PRINCIPLE 3.2

Registered professional engineers are aware of the legal requirements that pertain to their profession

A registered professional engineer must:

- practice in the field of engineering in which they are registered in accordance with all the legal, statutory and regulatory requirements
- take all reasonable steps to procure and maintain professional indemnity insurance during each year that is appropriate for the services being provided by the registered professional engineer
- be cognisant of their legal, statutory or regulatory responsibilities particularly related, but not limited, to:
  - discrimination, harassment and vilification
  - contracts
  - negligence
  - privacy and confidentiality
  - work health and safety

## 54.

### Further- information request

Accordingly I request immediately, the following information to be sent to myself, for myself and the auditors of the Board of Professional Engineers, and the Crime and Conduct Commission -

Surface levels and invert levels of Council staff engineered stormwater 6 pipes, 6 pits and kerb crossings, as per BSD 8111.

Calculations of fall of pipes, as per BSD 8111.

Council staff Engineering under S7.4.7, build over or near Council assets.

Reason for the sham rear triangle, DA cases for comparison, Planning Court cases for comparison.

Reason for incorrect location of Onsite Drainage pits and kerb and chanel.

Council Engineering for the site specific easement.

Declaration by Council in writing of all typographical errors and the reasons for those errors.

Declaration by each Council Development Assessment Team member as to who were the person/persons who performed the engineering in red and in the conditions.

If you cannot provide this information, I need to report this to the Board of Professional Engineers and the Crime and Corruption Commission.

**Further – BSD 8111 table**

## Document 21

Nil

## Document 22

## 55.

### **Above – letter to David Manteit from Margaret Orr 3/10/24.**

Margaret Orr stated that –

“Assessed by Council’s Development Team against the requirements of the Brisbane City Plan 2014.”

“Council’s Delegate took all matters into account”

It has been demonstrated by myself that indeed the Development Services Team have either not assessed, or have incorrectly assessed City Plan 2014, due to the Council staff (DST) performing professional engineering services that is non-compliant with Stormwater Codes, Brisbane Planning Scheme Policies, Brisbane Standard Drawings.

It is my view that there is proof that members of the Development Team have performed unlicenced professional engineering services.

Council DTS staff refuse to provide missing engineering information and a response as to why the Council staff professional engineering services is incompetent and non-compliance with Council laws.

## 56.

### **Orders proposed**

1) Please advise which Development Services Team persons in the case A006565555 performed licenced or unlicenced professional engineering services.

2) Please advise which Development Services Team persons in the case A006565555 performed unsupervised professional engineering services under an RPEQ.

3) Please provide a statement from each of the Development Services Team members stating whether or not they were the persons that performed professional engineering services, licenced or unlicenced and whether they were supervised by an RPEQ or not.

4) Please provide the following information required for all future expert witnesses –

Surface level and invert level of 6 pipes, pits and kerb crossing.

S12,17,18 - Fill the site quantity and location

S7.4.7 Build over or near stormwater S7 easement site specific easement.

S 7 Other easement.

Name of the engineer or DST member that drew the red lines and penned the fill conditions.

## 57.



### What are professional engineering services?

The term “**professional engineering services**” is defined in the *Professional Engineers Act 2002* as:

*an engineering service that requires, or is based on, the application of engineering principles and data to a design, or to a construction, production, operation or maintenance activity, relating to engineering, and does not include an engineering service that is provided only in accordance with a prescriptive standard.*

A prescriptive standard means a document that states procedures or criteria:

- (a) for carrying out a design, or a construction, production, operation or maintenance activity, relating to engineering; and
- (b) the application of which, to the carrying out of the design, or the construction, production, operation or maintenance activity, does not require advanced scientifically based calculations.

You may wish to get advice from a professional organisation or approved assessment entity as to whether your work involves “professional engineering services”.

## Professional engineers and the public sector

Engineers work in a variety of different fields and for a wide range of public sector agencies, including local councils, government-owned corporations, departments and statutory authorities. These types of agencies are called units of public administration (UPAs) and as such are within the CCC’s jurisdiction. (7)

If your work for any UPA requires you to carry out “professional engineering services” (see the text box to the left) and the work is not under the direct supervision of a practising professional engineer, you must be registered or you may be:

- Breaching the *Professional Engineers Act 2002*; and
- Committing corrupt conduct.

### Exemptions

However, you would not be committing corrupt conduct in the following circumstances:

- If the work you are doing for the UPA is not a professional engineering service.
- If your work is a professional engineering service, but it is under the supervision of a practising professional engineer.

### But how could I be corrupt?

#### I haven’t accepted a bribe or been dishonest!

Corruption, or “corrupt conduct” does not always or only mean dishonesty that involves, for example, accepting bribes, or appointing friends and family to public sector positions inappropriately.

You could potentially be involved in corrupt conduct if you are in breach of any of the legislation that governs your profession, such as the *Professional Engineers Act 2002*.

# Document 23

## 58.

Page 5 of 5

### EXPERT WITNESS – CRIMINAL LAWYER

Please confirm you will nominate a Criminal Lawyer who has full knowledge of criminal law in relation to the S115 of the Professional Engineers Act 2002 and the Crime and Corruption Commission Act 2001, as your expert witness, as in the order proposed in my last letter.

#### Orders proposed

- 1) Please advise which Development Services Team persons in the case A006565555 performed licenced or unlicenced professional engineering services.
- 2) Please advise which Development Services Team persons in the case A006565555 performed unsupervised professional engineering services under an RPEQ.
- 3) Please provide a statement from each of the Development Services Team members stating whether or not they were the persons that performed professional engineering services, licenced or unlicenced and whether they were supervised by an RPEQ or not.

4) Please provide the following information required for all future expert witnesses –

Surface level and invert level of 6 pipes, pits and kerb crossing.

S12,17,18 - Fill the site quantity and location

S7.4.7 Build over or near stormwater S7 easement site specific easement.

S 7 Other easement.

Name of the engineer or DST member that drew the red lines and penned the fill conditions.

I will be seeking orders on 12/2/25 from this Court no matter what the advices by Council in relation to the disputed conditons are, by 31/1/25, for Council and the Assessment Team members to provide the above information, for this Court and the Crime and Corruption Commission.

#### Final order

May draw your attention to my final order of the originating application, which, if allowed, seeks this Court's referral of the findings of this matter to other external parties.

Yours Faithfully

DAVID MANTEIT

## 59.



### Advice for all UPAs in relation

#### to professional engineering services

In relation to the complaint described at the beginning of this factsheet, the CCC assessed this complaint as suspected corrupt conduct and wrote to the Board of Professional Engineers, requesting them to deal with the allegations. The CCC also wrote to all council CEOs requesting that they conduct an audit of any positions that employed engineers, to ensure they were providing those services in a manner which was compliant with the Professional Engineers Act 2002.

To prevent any recurrence of such complaints, all UPAs should:

- Review the registration status of employees undertaking engineering services, to ensure compliance with the Professional Engineers Act 2002
- Take appropriate action to address practices, if any, contrary to the Professional Engineers Act 2002, and
- Flag such matters with their internal audit and risk units.

## Application of the definition of corrupt conduct to engineers' work

The definition of corrupt conduct could apply to you if:

- You work for an agency that is within the CCC's jurisdiction, and
- Your conduct is in breach of a law (e.g. the Professional Engineers Act 2002), and thus a criminal offence.

For example, you could be meeting the three criteria for Type A corrupt conduct:

- If you carry out your work – the function or activity you perform as part of your employment – in a manner that is contrary to the law, as the conduct **could adversely affect** that function. (*Effect of the conduct*)
- If the manner in which you work results in the performance of the function in a way that is a **breach of the trust** placed in a person holding the appointment. (*Result of the conduct*)
- Because a contravention of section 115(1) of the Professional Engineers Act is a criminal offence, so, if proved, it would be a **criminal offence**. (*Seriousness of the conduct*)



### Further information

For further information about the CCC or the complaints process, go to: [www.ccc.qld.gov.au](http://www.ccc.qld.gov.au)

For more information about professional engineering services, contact:

- Board of Professional Engineers of Queensland: [www.bpeq.qld.gov.au](http://www.bpeq.qld.gov.au)
- Institute of Public Works Engineering Australasia, Queensland: [www.ipweaq.com](http://www.ipweaq.com)
- Engineers Australia: [www.engineersaustralia.org.au](http://www.engineersaustralia.org.au)
- Professionals Australia: [www.professionalsaustralia.org.au](http://www.professionalsaustralia.org.au)



## 60.



### Professional Engineers Act 2002

Section 115 specifies the requirements for carrying out professional engineering services.

#### Section 115 - Who may carry out professional engineering services

- (1) A person who is not a practising professional engineer must not carry out professional engineering services. Maximum penalty—1000 penalty units.
- (2) However, a person does not commit an offence under subsection (1) if the person carries out the professional engineering services under the direct supervision of a practising professional engineer who is responsible for the services.
- (3) A person who is a practising professional engineer must not carry out professional engineering services in an area of engineering other than an area of engineering for which the person is registered under this Act.- Maximum penalty—1000 penalty units.
- (4) However, a person does not commit an offence under subsection (3) if the person carries out the professional engineering services under the direct supervision of a practising professional engineer who is registered in the area of engineering and responsible for the services.
- (5) For this section, a person carries out professional engineering services under the direct supervision of a practising professional engineer only if the engineer directs which person in the carrying out of the services and oversees and evaluates the carrying out of the services by the person.

Therefore, if you work for a UPA that is within the CCC's jurisdiction, such as a council or other government agency, and if your conduct is in breach of section 115 of the Professional Engineers Act 2002, or any other law, you may be committing corrupt conduct.

Let's look now at the definition of corrupt conduct.

## Document 24

61.

He who performs engineering for the world, eg, Development I, must be responsible for the engineering.

Council has a responsibility to be -

- transparent with their engineering
- not provide drawings and and perform engineering that is unsatisfactory conduct, of a Registered Professional Engineer as per Schedule 2 of the Professional Engineers Act.
- not produce or provide drawings that may be an offence under S115 of the Professional Engineers Act 2002 and The Crime and Corruption Act 2001, being engineering performed by unlicensed or unsupervised persons.

Should Council Plans be found unlawful, the conditon must be removed.

62.

## Document 26

**RTI review demonstrates that Lucy Ting, Scott Ruhland, sleepy Joel Wake, Andrew Blake and Roger Greenway and othe Council employees have not performed obvious engineering calculations which take 5 minutes ?**

**Why are these employees being paid by Brisbane City Council ratepayers?**

RTI review **provides** demonstration of alleged complete incompetence by Council employees and is evidence of unsatisfactory professional conduct, for a registered engineer.

Council employees refuse to supply the Council employee stormwater engineering calculations and information to David Manteit.

## 63.

Council employees are too embarrassed to provide the calculations for any way.

Council staff have refused to supply stormwater engineering design details to David Manteit or the Planning Court, for "not the only way". Apparently there are several ways, according to Sara McCabe and Council. No Council staff engineering has been supplied to David Manteit for "any way" whatsoever. Council employees know they have caused a flooding disaster at the kerb and onto the land at 128 Ashridge Rd.

## Document 27

## 64.

4. There is and has been withholding of Council employee engineering calculations in relation to Upstream and Onsite Drainage systems to the present day, by all of the abovenamed Council employees. This engineering information that has been requested by David Manteit, to Council employees over 30 times since 1/10/24.

## 65.

**An engineer is responsible for their own engineering.**

**66.**

**Council engineers are responsible for engineering. Council are responsible for their markups., causing over \$150,000 damages in other Courts.**

**Every engineer is responsible for their engineering and is liable at law for the damages caused by their engineering.**

**Board of Professional Engineers website has hundreds of examples of Engineers losing in court.**

**67.**

**Council employees refuse to supply the Council employee stormwater engineering calculations and information to David Manteit.**

**68.**

**Council staff have refused to supply stormwater engineering design details to David Manteit or the Planning Court, for "not the only way". Apparently there are several ways, according to Sara McCabe and Council. No Council staff engineering has been supplied to David Manteit for "any way" whatsoever. Council employees know they have caused a flooding disaster at the kerb and onto the land at 128 Ashridge Rd.**

## Document 28

69.

The Council employees have had 8 months to supply reasons why they have designed and engineered such unlawful engineering plans,

There is no other conclusion.

Time and time again, the Council employees had the chance. Meetings were held before the decision date to confirm their intentional actions.

The Council employees had every chance to provide an information request to the DA applicant and let a private engineer perform engineering, but they chose not to. They chose flood, damage and possible loss of life instead.



70.

8) Council employees have refused to supply engineering methodology information and calculations of their engineered design to David Manteit and the Planning Court.

71.

17) Joel Wake, Lucy Ting, Scott Ruhland, Andrew Blake, Margaret Orr, Zarndra Piper have demonstrated total incompetence to date by not providing any evidence whatsoever that they have engineered their "Upstream" or "Onsite" drainage red stormwater lines in accordance with any Council laws whatsoever.

## Extracts of laws

### 115 Who may carry out professional engineering services

- (1) A person who is not a practising professional engineer must not carry out professional engineering services.  
Maximum penalty—1000 penalty units.
- (2) However, a person does not commit an offence under subsection (1) if the person carries out the professional engineering services under the direct supervision of a practising professional engineer who is responsible for the services.
- (3) A person who is a practising professional engineer must not carry out professional engineering services in an area of engineering other than an area of engineering for which the person is registered under this Act.  
Maximum penalty—1000 penalty units.
- (4) However, a person does not commit an offence under subsection (3) if the person carries out the professional engineering services under the direct supervision of a practising professional engineer who is registered in the area of engineering and responsible for the services.
- (5) For this section, a person carries out professional engineering services under the direct supervision of a practising professional engineer only if the engineer directs the person in the carrying out of the services and oversees and evaluates the carrying out of the services by the person.

*unsatisfactory professional conduct*, for a registered professional engineer, includes the following—

- (a) conduct that is of a lesser standard than that which might reasonably be expected of the registered professional engineer by the public or the engineer's professional peers;
- (b) conduct that demonstrates incompetence, or a lack of adequate knowledge, skill, judgement or care, in the practice of engineering;
- (c) misconduct in a professional respect;
- (d) fraudulent or dishonest behaviour in the practice of engineering;
- (e) other improper or unethical conduct.

### 15 Meaning of corrupt conduct

- (1) **Corrupt conduct** means conduct of a person, regardless of whether the person holds or held an appointment, that—
  - (a) adversely affects, or could adversely affect, directly or indirectly, the performance of functions or the exercise of powers of—
    - (i) a unit of public administration; or
    - (ii) a person holding an appointment; and
  - (b) results, or could result, directly or indirectly, in the performance of functions or the exercise of powers mentioned in paragraph (a) in a way that—
    - (i) is not honest or is not impartial; or
    - (ii) involves a breach of the trust placed in a person holding an appointment, either knowingly or recklessly; or
    - (iii) involves a misuse of information or material acquired in or in connection with the performance of functions or the exercise of powers of a person holding an appointment; and
  - (c) would, if proved, be—
    - (i) a criminal offence; or
    - (ii) a disciplinary breach providing reasonable grounds for terminating the person's services, if the person is or were the holder of an appointment.
- (2) *Corrupt conduct* also means conduct of a person, regardless of whether the person holds or held an appointment, that

## Cases prosecuted by the Board of Professional Engineers



### **Board of Professional Engineers of Queensland v N**

This was a prosecution by the Board of Professional Engineers of Queensland ("**Board**") against **N** (deidentified) in the Magistrates Court of Queensland ("**Court**"). This was the Board's second prosecution of N.

#### **Charges**

Two separate complaints were made against N which contained a total of 14 charges of carrying out professional engineering services when not registered as a registered professional engineer. In addition, there were two charges of failing to attend an interview with the investigator appointed to consider the complaints, and a further three charges of failing to supply documents to the investigator.

#### **N's Background**

N was not registered as a registered professional engineer at any time while undertaking the work the subject of the prosecution.

#### **Conduct of N**

In 2007 N entered into an arrangement a registered professional engineer whereby the engineer would supervise and certify the engineering designs produced by N for various clients in exchange for a percentage of each invoiced sum. Over a period of some months, N carried out professional engineering services for a number of clients in relation to 13 properties across Brisbane. The work that N performed for these clients included designing a retaining wall, designing garages and carports, producing engineering drawings for house alterations, performing inspections of bored piers, footings, slabs, and timber framing, and producing designs for a deck. N undertook the engineering work in relation to these properties without the engineer's knowledge, and fraudulently issued a number of Form 15 Compliance Certificates for building Design or Specification and 16 Inspection Certifications for the unsupervised work affixing the engineer's scanned signature without the engineer's knowledge. N took steps to conceal the unsupervised work from the engineer, and denied undertaking work without approval when questioned by the engineer. The engineer subsequently discovered a USB stick belonging to N which contained details of the unsupervised work and fraudulent documents, and subsequently made a complaint to the Board. While investigations were being made by the Board in relation to the unsupervised work, N failed to attend interviews with the Board's investigator. N also failed to supply documents that were requested by the investigator.

#### **What the Court Said**

The evidence before the Court confirmed that (1) N has never been a registered professional engineer; (2) N had engaged the engineer to supervise the work, however none of the services provided in relation to the 13 properties were supervised by the engineer; (3) the works performed by N in relation to the 13 properties were professional engineering services, because they required or were based on engineering principles and data and were not simply provided in accordance with a prescribed standard; and (4) N was given a total of three notices by the appointed investigator which advised that N was required to attend interviews on two occasions, and which required the production of documents on three occasions and despite receiving the notices N failed to attend both interviews, failed to produce the required documents, and offered no reasonable excuse for not complying with the notices.

The Court was satisfied that N had provided professional engineering services while unsupervised at the 13 properties when not registered as a registered professional engineer, and found N guilty of the 14

charges. Further, the Court was satisfied that N had failed to attend interviews with the appointed investigator on two occasions and had failed to produce documents to the investigator on three occasions. As such, the Court also found N guilty of the five charges in this respect.

#### **Consequences for N**

In determining the appropriate penalty, the Court took into account a number of factors, including that: (1) N had previously been convicted of similar offences, and had full knowledge that the conduct was not permitted under the Act; (2) N had not been deterred by the fine imposed by the Court for the previous conviction; (3) there is a need to both protect the public by ensuring engineering services are provided by a registered professional engineers in a competent way, and to maintain public confidence in the integrity of the registration system; (4) as an undischarged bankrupt, N's ability to pay a large monetary penalty must be considered; and (5) the total penalty to be imposed upon N must not be crushing.

Taking the above factors into consideration, the Court ordered that N pay a large global penalty for all 19 charges, and recorded a conviction. The Court also ordered that N pay the Board's costs.



#### **Board of Professional Engineers v X**

Delivered on 22 October 2013.

This was a prosecution by the Board of Professional Engineers of Queensland ("Board") against X (deidentified) in the Magistrates Court of Queensland ("Court").

#### **Charges**

The Board alleged that X, in breach of section 115 of the *Professional Engineers Act 2002* ("the Act"), carried out professional engineering services when he was not, at that time, a Registered Professional Engineer of Queensland ("RPEQ").

#### **X's Background**

X was a sole trader based in New South Wales.

#### **Conduct of X**

X was engaged to re-design and provide certification of the repair of a Rod Loader, located in Queensland, and to increase its working load limit from 500kgs to 680kgs.

X had failed to check the requirements for carrying out professional engineering services in Queensland prior to completing the work and consequently he was not registered when he undertook the re-design and provided the certification in Queensland.

#### **What the Court Said**

The Court noted the importance of registration to the operation of the Act and its objects to protect the safety and welfare of the public.

#### **Consequences for X**

The Court took into account X's early plea of guilty to the charges.

The Court considered that any penalty to be imposed would need to act as a general deterrent against people practicing or purporting to practice as engineers in Queensland when they are not registered as required by the Act.

The Court found X guilty of the offence, imposed a monetary penalty, and ordered X to pay the Board's costs.





## **Board of Professional Engineers v S**

Delivered on 12 December 2012.

This was a prosecution by the Board of Professional Engineers of Queensland ("**Board**") against **S** (deidentified) in the Magistrates Court of Queensland ("**Court**").

### **Charges**

The Board alleged that S, in breach of section 115 of the *Professional Engineers Act 2002* ("**the Act**") carried out professional engineering services when he was not, at that time, a registered professional engineer ("**RPEQ**").

### **S's Background**

S had previously been registered as a RPEQ but on several occasions had allowed that registration to lapse.

### **Conduct of S**

S directed the release of water from two dams during a flood event, as stipulated by modeling predictions for those dams, by calculating the required water releases for each and preparing directives in relation to the release of water from the dams.

The Board alleged that those services were professional engineering services which could only be undertaken by a RPEQ, which S was not at that time.

### **What the Court Said**

In determining the appropriate penalty the Court considered that a good behavior bond would not adequately reflect the intention of the Act. The Court stated that it is imperative to maintain registration, and to have that as the mark of a professional engineer.

### **Consequences for S**

The Court considered that it was appropriate that a penalty be imposed for a failure by an engineer to maintain registration, particularly so in S's circumstances whereby S had allowed his registration to lapse on a number of occasions, remaining unregistered for a considerable period of time before S renewed the registration on each occasion.

The Court found S guilty of the offence, imposed a monetary penalty, and ordered that S pay the Board's costs.