



E3 SYSTEMS LTD.

YOUR ONE STOP MARKING AND DECORATING SOLUTION PROVIDER SINCE 1975



CFIB



ALIEN-100-2/TT

Fast, highly flexible, Quick 3 minute job change
Print one side + load/unload on other side

INCLUDES
GREEN
INK CUP



FEATURES

- ✦ Servo motor driven pad stroke (optional)
- ✦ Rigid aluminum casting machine frame
- ✦ APS: Automatic pad stroke by optical scale
- ✦ Use sealed ink cup set up
- ✦ Compatible with long life thin steel, polymer, 10mm steel
- ✦ Dead-On printing plate registration for quick job change
- ✦ Fast set up, snap-on plate change
- ✦ Optional automatic pad clean with programmable cleaning cycle
- ✦ Special functions: double ink/print cycles, dwell and delay before print
- ✦ Hardened ground steel shaft with impregnated bushing ensure friction-free movement
- ✦ High speed and smooth machine operations
- ✦ RS-232 (In-line setup)
- ✦ European safety CE
- ✦ Ontario Hydro electrical safety approved

SPECIFICATIONS

Ink cup:	Ø90mm
Die plate size:	100 x 250mm
Effective printing area:	Ø80mm
Pad stroke:	0-60mm (optional scale)
Max. speed: (dry cycle)*	3,600 cycles /hr.
Max. pad pressure	480N at 6 Bar/100 PSI
Turntable Size:	Ø280mm
Index Stations:	2
Number of Fixtures	2
Power:	110/220v 50/60Hz 30W
Air consumption:	110 litres per cycle
Size: (LxWxH): Ink cup model	635 x 420 x 570mm
Weight:	80 Kg (approx.)

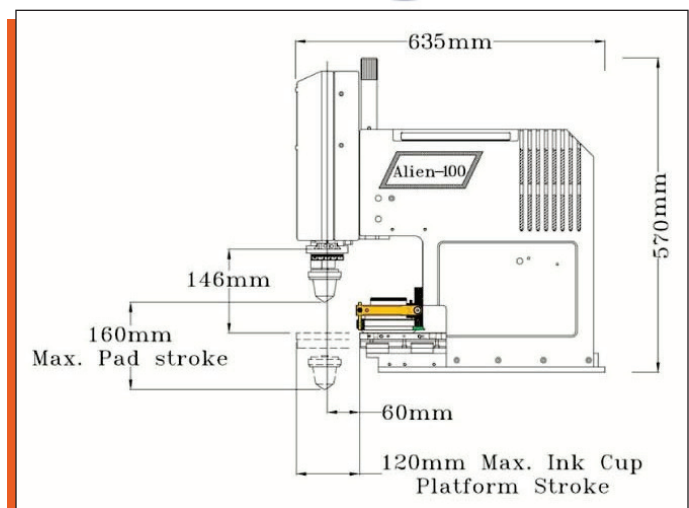

*Please note that actual output may be affected by print requirement, ink drying condition, load/unload arrangement, pad stroke speed, pad hardness, production setup, product quality and production control.

APPLICATIONS

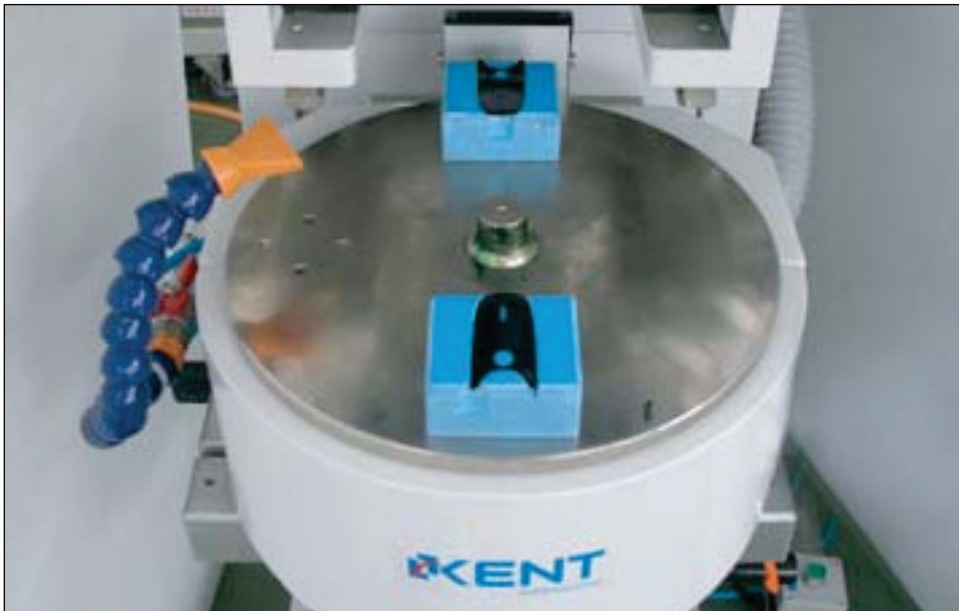

2-Station

NOTE: IMAGE MUST FIT WITHIN 3.0" DIAMETER COVERED BY THE INK CUP

Ask us for a special pricing on a complete package which includes Alien-100-2/TT Pad Printer System, Start-up package, Delivery, Set-up and Training.



Lease from \$99.99 per month O.A.C.

This special financing program has been created to give you the opportunity to begin cash flow stream during your first 12 months. Lease through National Leasing: 100% Business Write Off, 5 Year Fixed Rate Lease, No Money Down, No Up Front Administration Fees, \$99.99 Per Month For The First 12 Months With A 10% Early Purchase Option On Approved Credit. Other Terms Available.

9-1060 SALK ROAD, PICKERING, ONTARIO, CANADA L1W 3C5 ▲ T(905) 420-3311 ▲ F(905) 420-3377 ▲ e3systems.ca

