



E3 SYSTEMS LTD.

YOUR ONE STOP MARKING AND DECORATING SOLUTION PROVIDER SINCE 1975



CFIB



ALIEN-100

High-Speed & High Print Accuracy
Stand-Alone or Modular pad printer

FEATURES

- ✦ Servo motor driven pad stroke (optional)
- ✦ Rigid aluminum casting machine frame
- ✦ APS: Automatic pad stroke by optical scale
- ✦ Use sealed ink cup set up
- ✦ Compatible with long life thin steel, polymer, 10mm steel
- ✦ Dead-On printing plate registration for quick job change
- ✦ Fast set up, snap-on plate change
- ✦ Optional automatic pad clean with programmable cleaning cycle
- ✦ Special functions: double ink/print cycles, dwell and delay before print
- ✦ Hardened ground steel shaft with impregnated bushing ensure friction-free movement
- ✦ High speed and smooth machine operations
- ✦ RS-232 (In-line setup)
- ✦ European safety CE
- ✦ Ontario Hydro electrical safety approved



SPECIFICATIONS

| | |
|------------------------------|------------------------|
| Ink cup: | Ø90mm |
| Die plate size: | 100 x 250mm |
| Effective printing area: | Ø80mm, 40x60mm |
| Pad stroke: | 0-160mm (250 optional) |
| Max. speed: (dry cycle)* | 3,600 cycles /hr. |
| Max. pad pressure | 4800N at 6 Bar/100 PSI |
| Power: | 110/220v 50/60Hz 30W |
| Air consumption: | 110 litres per cycle |
| Size: (LxWxH): Ink cup model | 635 x 420 x 570mm |
| Weight: | 40 Kg (approx.) |

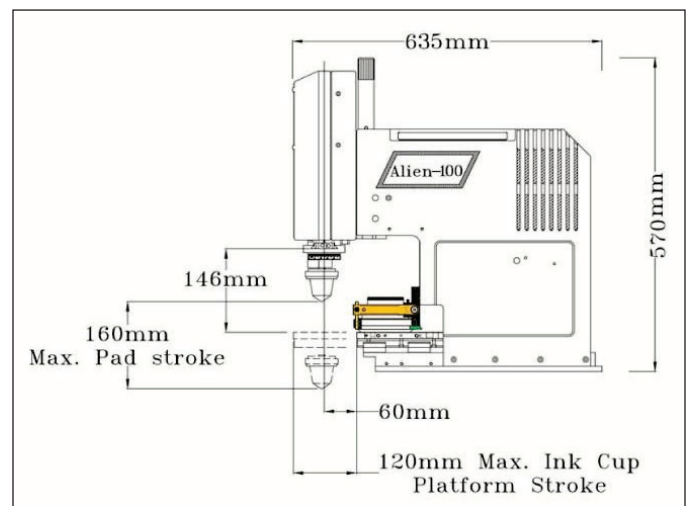

*Please note that actual output may be affected by print requirement, ink drying condition, load/unload arrangement, pad stroke speed, pad hardness, production setup, product quality and production control.

APPLICATIONS



ALIEN-IN-LINE



STAND-ALONE WITH
AUTOMATIC PAD CLEAN



2-STATION WITH
PNEUMATIC TURNTABLE



ALIEN ON TURNTABLE MULTI-COLOURS SET-UP



IN-LINE AUTOMATION

NOTE: IMAGE MUST FIT WITHIN 3.0" DIAMETER COVERED BY THE INK CUP

Ask us for a special pricing on a complete package which includes Alien-100 Pad Printer System, Recommended Starter Package, Delivery, Set-up and Training.



Lease from \$99.99 per month O.A.C.

This special financing program has been created to give you the opportunity to begin cash flow stream during your first 12 months. Lease through National Leasing: 100% Business Write Off, 5 Year Fixed Rate Lease, No Money Down, No Up Front Administration Fees, \$99.99 Per Month For The First 12 Months With A 10% Early Purchase Option On Approved Credit. Other Terms Available.

9-1060 SALK ROAD, PICKERING, ONTARIO, CANADA L1W 3C5 ▲ T(905) 420-3311 ▲ F(905) 420-3377 ▲ e3systems.ca

