



ONTARIO AMENDMENTS TO THE CANADIAN ELECTRICAL CODE PART I, C22.1-09

As amended

December 12, 2008



For Your Safety

Sections 0 through 86 of the Canadian Electrical Code Part I C22.1-0, exclusive of any references to any of the appendices, is adopted as part of the Electrical Safety Code with the following amendments:

1. **Delete the CE Code Subsection entitled Object. Delete the CE Code Subsection entitled Scope.**
2. **Delete the CE Code definition of “acceptable” and replace with:**
Acceptable — not presenting an undue hazard to persons or property under the circumstances.
3. **Delete the CE Code definition of “accredited certification organization” and replace with:**
Accredited Certification Organization — see definition for Certification Organization.
4. **Add the following definition:**
Applicable standards — standards of design, construction, testing, and marking, as adopted by the Inspection Department,
 - (a) that are applied to electrical equipment by certification organizations, field evaluation agencies, professional engineers, or other competent persons who inspect, test, and report upon electrical equipment; and
 - (b) that are intended to prevent exposure of persons and property to undue hazards.
5. **Delete the CE Code definition of “approved (as applied to electrical equipment)”**
Approved — authorized or approved in accordance with this Code.
6. **Add the following definition:**
Certification Organization — a “Certification Body” as defined in Ontario Regulation 438/07 and is a body accredited in accordance with the Standards Council of Canada Act (Canada) to evaluate electrical equipment and is recognized by the Inspection Department.
7. **Add the following definition:**
Connection authorization — when concerning supply of electrical energy to an electrical installation from a supply authority, signifies written permission by the



For Your Safety

inspection department to a supply authority, or any other person or corporation, to supply electric energy to a particular electrical installation; and

when concerning supply of electric energy from one part of an electrical installation to another, or from a source of electric energy other than that of a supply authority, signifies permission from the inspection department to a contractor to connect a particular electrical installation or part thereof to a source of electric energy.

8. Add the following definition:

Contractor — any person who as principal, servant, or agent, by himself or herself or by associates, employees, servants or agents performs or engages to perform, either for his or her own use and benefit or for that of another, and for or without remuneration or gain, any work with respect to any electrical installation or any other work to which this Code applies.

9. Add the following definition:

Critical injury — an injury of a serious nature that

- (a) places life in jeopardy;
- (b) produces unconsciousness;
- (c) results in a substantial loss of blood;
- (d) involves the fracture of a leg or arm but not a finger or toe;
- (e) involves the amputation of a leg, arm, hand or foot but not a finger or toe;
- (f) consists of burns to a major portion of the body; or
- (g) causes the loss of sight in one eye.

10. Delete the CE Code definition of "current-permit".

11. Delete the CE Code definition of "electrical equipment" and replace with:

Electrical equipment — an "electrical product or device" as defined in subsection 113.12.1 of Part VIII of the Electricity Act, 1998, and means any thing used or to be used in the generation, transmission, distribution, retail or use of electricity.

12. Delete the CE Code definition of "electrical installation" and replace with:

Electrical installation — the installation of any wiring in or upon any land, building, or premises from the point(s) where electric power or energy can be supplied from any source, to the point(s) where such power or energy can be used therein or thereon by any electrical equipment and includes the connection of any such wiring with any of the



For Your Safety

said equipment and any part of that wiring, and also includes the maintenance, alteration, extension, and repair of such wiring.

13. Add the following definition:

Field evaluation agency — a “Field evaluation agency” as defined in Ontario Regulation 438/07, and is an inspection body accredited in accordance with the Standards Council of Canada Act (Canada) to evaluate electrical equipment and is recognized by the Inspection Department.

14. Delete the CE Code definition of “inspection department” and replace with:

Inspection department — Electrical Safety Authority, as designated by regulation pursuant to the Electricity Act, 1998.

15. Add the following definition:

National Building Code of Canada — the Ontario Building Code.

16. Add the following definition:

Requirements of the supply authority — a code or standard under a rule or by-law of a municipal corporation or commission or under a rule of a person supplying power to such works.

17. Add the following definition:

Serious electrical incident —

- (a) any electrical contact that causes death or critical injury to a person;
- (b) any fire, explosion or condition suspected of being electrical in origin that might have caused a fire, explosion, loss of life, critical injury to a person, or damage to property;
- (c) any electrical contact with electrical equipment operating at over 750 V; or
- (d) any explosion or fire of electrical equipment operating at over 750 V.

18. Delete the CE Code definition of "special permission".

19. Delete the CE Code definition of “utilization equipment” and replace with:

Utilization equipment — see definition for Electrical equipment.



For Your Safety

20. Add the following definition:

Volt-amperes (with respect to an electric circuit) — the mathematical product of the voltage and amperage carried thereby.

21. Delete Rules 2-000 through 2-036 of the CE Code and replace with:

2-000 Scope

This Code does not apply to

- (a) electrical equipment and electrical installations used exclusively in the generation, transmission, or distribution of electrical power or energy intended for sale or distribution to the public, where
 - (i) the distributor is licensed to own or operate the distribution system under Part V of the Ontario Energy Board Act, 1998;
 - (ii) the transmitter is licensed to own or operate the transmission system under Part V of the Ontario Energy Board Act, 1998; or
 - (iii) the generator is licensed to own or operate the generation system or is licensed to provide ancillary services for sale through the IESO-administered markets or directly to another person, under Part V of the Ontario Energy Board Act, 1998;
- (b) electrical equipment and electrical installations in communication systems from the transformer or other current-limiting device used at the junction of the communication system with the electric circuit supplying the communication system;
- (c) electrical equipment and electrical installations in the cars, car-houses, passenger stations or freight stations used in the operation of an electric railway or electric street railway and supplied with electric current from the railway power-circuit;
- (d) electrical equipment and electrical installations in railway locomotives, railway cars, signalling systems, communication systems, wayside train monitoring systems, and track facilities including the branch circuit supplying such electrical equipment or electrical installations when such electrical equipment or electrical installation is used in the operation of a railway;
- (e) electrical equipment and electrical installations in an aircraft;
- (f) electrical equipment and electrical installations in a mine as defined in the Mining Act, excluding any dwelling house or other building not connected with, or required for, mining operations or purposes or used for the treatment of ore or mineral;
- (g) electrical equipment and electrical installations on a vessel of non-Canadian registry or on a vessel that is required to be certified in accordance with the Canada Shipping Act except for such equipment and installations required to connect the electrical supply from the onshore electrical supply facility to the service box on the boat and including the service box; or



For Your Safety

- (h) electrical equipment forming an integral part of a self-propelled vehicle that is required to be certified in accordance with the Motor Vehicle Safety Act except for such equipment supplying electrical power from an electrical installation to the vehicle and those portions of a vehicle capable of receiving electrical power from an electrical installation.

2-002 Special requirements

Sections devoted to Rules governing particular types of installations are not intended to embody all Rules governing these particular types of installations, but cover only those special Rules that add to or amend those prescribed in other sections covering installations under ordinary conditions.

2-003 Record of electrical installation work

The owner, owner's agent, or operator shall maintain a record of all electrical installation acceptable to the inspection department in any public building, commercial or industrial establishment, apartment house, or other building in which the public safety may be involved and shall produce this record to any inspector at any time and from time to time upon request, as specified by the inspection department.

2-004 Inspection

- (1) A contractor shall file with the inspection department a completed application for inspection of any work on an electrical installation:
 - (a) before or within 48 hours after commencement of the work whether or not electrical power or energy has been previously supplied to the land, building, or premises on which the work was performed;
 - (b) shall pay the fees prescribed by the inspection department; and
 - (c) be in compliance with Ontario Regulation 570/05 made under Part VIII of the Electricity Act, 1998.
- (2) An application for inspection that has been refused in accordance with the provisions of Rule 2-008 shall, for the purposes of Subrule (1), be deemed not to be a completed application.
- (3) Every contractor who undertakes an electrical installation is responsible for ensuring that the electrical installation complies with this Code and for procuring an authorization for connection from the inspection department before the installation is used for any purpose.
- (4) The contractor shall give to the inspection department at least forty-eight hours' notice in writing that the work on the electrical installation has been completed and that the installation is ready for a connection authorization, but where the work is being performed in a remote district or is not immediately accessible for any other reason, the notice shall be of such greater length as is necessary to accommodate the inspection schedule of the inspection department.
- (5) Inspections as required by the inspection department may be made at such time and in such manner as the inspection department determines.

For Your Safety

- (6) An electrical installation shall not be concealed or rendered inaccessible until it conforms to this Code and such concealment or rendering inaccessible has been authorized by an inspector.
- (7) An inspection may be deemed by the inspection department to have been made for an electrical installation or a group of electrical installations and connection authorized even though all portions of any installation in the group and all installations in the group have not been inspected, provided that
 - (a) a contractor files with the inspection department a completed application for inspection of any work on an electrical installation or a group of electrical installations within the time specified by the inspection department, whether or not electrical power or energy has been previously supplied to the land, building, or premises on which the work was performed;
 - (b) the contractor is qualified in accordance with Subrules (8) and (9);
 - (c) there is compliance with Subrules (1)(b), (2), (3), and (4);
 - (d) the contractor has provided assurance acceptable to the inspection department that all portions of any installation or group of installations comply with this Code; and
 - (e) portions of the installations have been inspected by the inspection department and all inspected portions conform to this Code.
- (8) A contractor may be eligible for the process in Subrule (7) where the application for inspection and for a connection authorization is made by
 - (a) a contractor who
 - (i) is licensed, registered or certified through appropriate examination by an appropriate authority to carry on trade as an electrical contractor;
 - (ii) holds a valid appropriate certificate of qualification issued to the contractor in accordance with the provisions of The Trades Qualification Act;
 - (iii) holds appropriate liability insurance; and
 - (iv) has demonstrated knowledge of this Code, as it applies to the installations, that is satisfactory to the inspection department;
 - (b) a contractor who:
 - (i) holds a valid appropriate certificate of qualification issued to the contractor in accordance with the provisions of The Trades Qualification Act;
 - (ii) holds appropriate liability insurance; and
 - (iii) has demonstrated knowledge of this Code, as it applies to the installations, that is satisfactory to the inspection department; or
 - (c) a contractor who
 - (i) has demonstrated competency through appropriate training and examination or in other ways;
 - (ii) holds appropriate liability insurance; and



For Your Safety

- (iii) has demonstrated knowledge of this Code, as it applies to the installations, that is satisfactory to the inspection department.
- (9) Where an installation is such that an application for inspection covers work by more than one individual, the inspection department may require some or all individuals performing work on an installation to satisfy Subrule (8) as a condition for following the process in Subrule (7).
- (10) Where Subrule (7) is followed, the particular installations in the group and the particular portions of the installations in a group inspected shall be determined by the inspection department.
- (11) The inspection department may refuse to follow the process in Subrule (7) where work by the contractor has been found to be contrary to the requirements of this Code.

2-005 An application for inspection not required

Notwithstanding the provisions of Rule 2-004, an application for inspection is not required

- (a) in an owner-occupied single dwelling for the installation of replacement equipment (such as fuses, receptacles, luminaires, general-use switches, utilization equipment, transformers for extra-low voltage circuits or equipment in extra low voltage circuits) if the equipment being installed
 - (i) is installed by an electrical contractor licensed in accordance with Regulation 570/05;
 - (ii) is installed in a branch circuit having a rating not exceeding 30 A and 130 V;
 - (iii) is interchangeable with the equipment being replaced in function, electrical rating, size, and weight without having to change any part of the branch circuit;
 - (iv) is installed in the same location as the equipment being replaced;
 - (v) is approved in accordance with Rule 2-024;
 - (vi) is not electrical equipment forming part of an electrical installation to which Section 68 of this Code applies; and
 - (vii) does not involve the repair, modification or replacement of a service box or a panel board or the replacement of an electro-mechanical over-current device in a service box or panel board; or
- (b) if an approved meter-base plug-in transfer device is installed by an electrical contractor licensed in accordance with Regulation 570/05.

2-006 Periodic inspection

- (1) An application for inspection may be made by the owner, owner's agent or occupant of any manufacturing, mercantile, or other building where electrical installation work of a routine nature in connection with the maintenance or operation of the building or the plant therein is required to be performed at frequent intervals.



For Your Safety

- (2) Acceptance of the application by the inspection department shall authorize the commencement and execution of such work during the period for which the acceptance is issued, and Rule 2-004 shall not apply.
- (3) Upon request, an inspection shall be made at such time and in such manner as the inspection department determines.

2-007 Reporting of serious electrical incidents

- (1) An owner, contractor or operator of a facility shall report to the inspection department any serious electrical incident of which it is aware within forty-eight hours after the occurrence.
- (2) No person shall, except in the interests of public safety, saving life, relieving human suffering, continuity of service or preservation of property, interfere with or disturb any wreckage, article or thing at the scene of and connected with the occurrence, but in no case shall the wreckage, article or thing be carried away or destroyed by any person unless permission to do so is given by an inspector.

2-008 Right of refusal

The inspection department may refuse an application for inspection authorization to any person

- (a) who has failed to pay any fees or dues owing to the inspection department for a period of more than thirty days;
- (b) who has failed to remedy defects in any electrical work or in any installation after having been notified by the inspection department that the defects exist; or
- (c) who is not licensed to operate an electrical contracting business under Regulation 570/05;
until
 - (i) the fees have been paid;
 - (ii) the defects have been remedied; or
 - (iii) in compliance with Regulation 570/05.

2-010 Plans and specifications (see Appendix B)

- (1) Electrical work on any electrical installation shall not commence until plans have been submitted and examined by the inspection department where the electrical installation involves
 - (a) a three-phase consumer service or standby generation, equal to or in excess of 400 A circuit capacity;
 - (b) a single-phase consumer service or standby generation equal to or in excess of 600 A;
 - (c) a feeder greater than 1000 A;
 - (d) any installations involving consumer-owned, electric-power-generating equipment, with a rating in excess of 10 kW (Micro size) as defined by the OEB, and operating in parallel with a supply authority system; or
 - (e) any installation operating in excess of 750 V, excluding

For Your Safety

- (i) installations of pole lines exclusively within the scope of Section 75;
or
 - (ii) that portion of an underground installation between a supply authority-owned transformer and the related supply authority-owned switch.
- (2) Plans need not be submitted for maintenance/repair work.
- (3) Plans need not be submitted for the replacement of circuit breakers, disconnects switches, transfer switches, splitters, services, panel boards, motor control centres, standby generators, switchboards, transformers, all operating at 750 V or less, provided that
 - (a) equipment ampere ratings are equal to the existing equipment ratings;
 - (b) all other ratings are equal to or exceed the existing equipment ratings; and
 - (c) the existing installation meets the requirements of this Code.
- (4) A copy of the examined plans shall be available on site and a copy of the inspection department's code compliance report shall be attached to the plans or the inspection department's report number shall be written on the plans.
- (5) The person responsible for the plan design shall file with the inspection department complete wiring plans and specifications relating to the proposed work and shall pay the Plan Review fees as prescribed by the inspection department.
- (6) For installations that proceed in phases, plans may be submitted as the project progresses, and the work of each phase shall not commence until the plans for that phase have been examined.
- (7) Those plans and specifications that are submitted shall contain the following information, where applicable:
 - (a) the name and address of the person responsible for their preparation;
 - (b) the type of building or electrical installation and the site where the work will be carried out;
 - (c) the location of the service and distribution;
 - (d) the supply voltage and the single line diagram of the service and distribution;
 - (e) the loads, the rating of the protection, and the identification of the feeder and branch circuits at their respective panelboards;
 - (f) the kV•A or ampere rating, interrupting or withstand rating, and ampere rating for continuous operation (80 or 100%) of each item of equipment;
 - (g) the type and size of raceways;
 - (h) the number and rating of conductors in raceways;
 - (i) the rating of cables;
 - (j) the type of materials, accessories or fixtures installed in hazardous locations;
 - (k) the size and location of grounding conductors;
 - (l) a description of underground parts of the installation;



For Your Safety

- (m) for an addition to an existing electrical installation, any information related to the existing installation affected by the works and a report on the existing loads or the maximum demand loads of the existing installation recorded for the last twelve months; and
- (n) for an electrical installation of more than 750 V, the vertical and horizontal clearances of live parts, and a description of the grounding and of the mechanical protection of live parts.

2-012 Connection authorization

- (1) Where any electrical installation or part thereof to which electric power or energy has not previously been supplied is made in or upon any land, building or premises, or subject to Subrule (2), where any electrical installation or part thereof has been disconnected or cut off from any service or other source of supply under this Code, no supply authority, contractor, or other person shall connect or re-connect the installation or part thereof to any service or other source of supply unless
 - (a) the installation and all related work have been inspected in accordance with the procedures in Rule 2-004 by an inspector; and
 - (b) a connection authorization has been issued by the inspection department with respect to the installation.
- (2) Where any electrical installation or part thereof has been disconnected or cut off from a source of supply by a supply authority for six months or less for non-payment of rates or because of a change of occupancy of premises, the supply authority may reconnect the installation or part thereof without obtaining a connection authorization.

2-013 Connection authorization not required

Notwithstanding the provisions of Rule 2-012, a connection authorization for an electrical installation or part thereof is not required if the installation does not require an application for inspection in accordance with the provisions of Rule 2-005.

2-014 Temporary connection authorization

- (1) Notwithstanding the provisions of Rule 2-012, the inspection department may issue a connection authorization authorizing a supply authority, contractor or other person to connect a source of electric energy for a stated length of time and under specific conditions to a temporary electrical installation or to a permanent but unfinished electrical installation and may renew the connection authorization from time to time.
- (2) Issuance of a connection authorization in accordance with Subrule (1) does not obligate the inspection department to issue a permanent connection authorization for an installation that is not in compliance with this Code.



For Your Safety

2-016 Re-inspection

The inspection department may at any time re-inspect any electrical installation notwithstanding any previous inspection and acceptance of the installation.

2-018 Defects

- (1) Every contractor who has performed work on an electrical installation and has been notified by the inspection department that the installation does not conform to this Code shall remedy all defects in work and replace all electrical equipment that is not approved within such time and in such manner as the notice from the inspection department directs.
- (2) Every person who has submitted an application for inspection of an installation or portion thereof that has not previously been authorized to receive power and who has been notified by the inspection department that the installation does not conform to this Code shall remedy all defects in work and replace all electrical equipment that is not approved within such time and in such manner as the notice from the inspection department directs.
- (3) The inspection department may, by notice in writing, require any owner or occupant of land, buildings or premises, upon or within which is found an electrical installation in which a condition dangerous to persons or property has developed, to make such changes in the electrical installation as are necessary to remedy the condition.
- (4) Upon receipt of the notice referred to in Subrule (3), the owner or occupant of the lands, buildings, or premises shall cause the installation to be changed in the manner and to the extent prescribed by the notice within the time limit.
- (5) Where a contractor or person refuses or neglects to comply with a notice given under Subrules (1) or (2), or the owner or occupant of lands, buildings or premises refuses or neglects to comply with a notice given under Subrule (3), the inspection department may disconnect the supply, or require the supply authority to disconnect the supply of electrical power or energy to the lands, buildings or premises in which is contained the electrical installation that was the subject of the notice.
- (6) If the supply has been disconnected pursuant to Subrule (5), it shall not be reconnected until full compliance with the notice has been made.

2-022 Sale or other disposal and use

- (1) No person shall use, advertise, display, sell, offer for sale or for other disposal any electrical equipment unless it has been approved in accordance with Ontario Regulation 438/07.
- (2) If a certification report or a field evaluation report relating to any approved electrical equipment requires that a notice indicating the proper and safe manner of use of the electrical equipment be affixed to the electrical equipment or be provided with it, no person shall use, advertise, display, sell, offer for sale or other disposal of the electrical equipment without affixing or providing the notice

For Your Safety

- in the manner required, as required by Section 5 (3) of Ontario Regulation 438/07.
- (3) Notwithstanding Subrule (1), electrical equipment does not require approval under Rule 2-024 or Ontario Regulation 438/07 if
- (a) it is displayed at a trade show or is activated in a demonstration of its use; and
 - (b) permission to display or activate it is given by the inspection department; or
 - (c) it is connected to the load side of an approved class 2 power supply whose power output does not exceed 100 V•A and is operating at less than 42.4 V peak or dc with the exception of
 - (i) luminaires, decorative lighting strings, signs or displays with incandescent or halogen lamps;
 - (ii) luminaires, decorative lighting strings, signs or displays incorporating a ballast with operating voltages greater than 42.4 V peak or dc;
 - (iii) electromedical equipment;
 - (iv) equipment for hazardous locations as defined under Sections 18 and 20 of this Code; or
 - (v) equipment that incorporates heating elements.

2-024 Approval of electrical Equipment

- (1) Electrical equipment shall be deemed to be approved if it has been approved according to the process set out in Section 2 of Ontario Regulation 438/07.
- (2) No person shall affix to any electrical equipment an approval label that was not issued for that electrical equipment.
- (3) If electrical equipment that is used in or connected to an electrical installation is inspected in accordance with Rule 2-004 by the inspection department, it shall be deemed to be approved if the installation and electrical equipment pass the inspection.

2-026 Cancellation of approval

- (1) The inspection department may suspend, revoke or reinstate the approval of electrical equipment according to the process set out in Subsection 6 of Ontario Regulation 438/07 and according to the rules developed by the inspection department.
- (2) If an approval is suspended or revoked, the electrical equipment shall be deemed not to be approved.
- (3) The inspection department may require that notice be given to the public or any person or class of persons by the persons identified in Section 9 of Ontario Regulation 438/07.



For Your Safety

2-028 Miscellaneous

If electrical equipment consists of or incorporates a component(s) that is deemed to be approved under this Section, the electrical equipment shall not be deemed to be approved unless the whole electrical equipment as assembled is deemed to be approved according to the process set out in Rule 2-024 and Section 2 of Ontario Regulation 438/07.

2-030 Deviation or postponement

A deviation from or postponement of the requirements of this Code is lawful in respect of an electrical installation where adequate proof that the deviation or postponement does not create an undue hazard to persons or property under the circumstances has been provided to the inspection department.

2-032 Damage and Interference

- (1) No person shall damage or cause any damage to any electrical installation or electrical equipment.
- (2) No person shall interfere with any electrical installation or electrical equipment in the course of alterations or repairs to non-electrical equipment or structures except where it is necessary to disconnect or move components of an electrical installation, in which event it shall be the responsibility of the person carrying out the alterations or repairs to ensure that the electrical installation is restored to a safe operating condition as soon as the progress of the alterations or repairs permits.
- (3) No person shall remove any tag, seal or warning applied to an electrical installation or applied to electrical equipment by the inspection department from that electrical installation or electrical equipment without permission from the inspection department.

2-034 Use of approved equipment

No person shall use electrical equipment for any purpose or in any manner other than the purpose or manner for which it is intended.

2-036 General

No contractor shall perform any work on an electrical installation in any manner contrary to the requirements of this Code.

22. Delete CE Code Rule 2-102(1) and (3) and replace with:

2-102 Rebuilt equipment

- (1) Where any electrical equipment is rebuilt or rewound with any change in its rating or characteristics, it shall be provided with a nameplate giving the name of the person or firm by whom such change was made together with the new marking.



For Your Safety

- (3) The appropriate requirements of the appropriate standard applying to new electrical equipment shall also apply to rebuilt and rewound equipment unless it is impracticable to comply with such requirements.

23. Add Section 3 as follows:

Section 3 — Field evaluation of electrical equipment

3-000 Scope

This Section applies to the approvals of electrical equipment in accordance with Rule 2-024 and Subsection 2 (2) of Ontario Regulation 438/07 and supplements or amends other requirements of this Code.

3-002 Standards

Sections 1 through 6 of SPE 1000-99, Model Code for the Field Evaluation of Electrical Equipment, prepared by the Canadian Standards Association is adopted as part of this regulation with the following amendments:

Delete Clauses 4.27, 4.28.1, 4.29, and 4.30.

Replace Clause 1.7 (e) with: Components that will require further evaluation as part of a complete assembly, such as switches, relays, and timers.

Add Clause 4.1.2.8: Switches and controls shall comply with the requirements of CAN/CSA-C22.2 No. 14 and CSA C22.2 No. 24, 55, 111, and 156, as applicable.

Add Clause 4.1.3.3: Transformers shall comply with the requirements of CSA C22.2 No. 66 and CAN/CSA-C22.2 No. 47, as applicable.

Add Clause 4.1.4.8: Motors shall be of types suitable for the particular application of the equipment and shall comply with the applicable requirements of CSA C22.2 No. 100.

Add Clause 4.1.6.3: Receptacles for attachment plugs shall comply with the requirements of CAN/CSA-C22.2 No. 42 and the Canadian Electrical Code, Part I, as applicable.

Replace Clause 4.23.3 with: Electrolytic or other special types of capacitors, and capacitors intended for connecting directly across the line, shall comply with the requirements for capacitors as specified in CSA C22.2 No. 8.

Add Clause 4.24.2: Suppressors used for suppressing radio interference shall comply with CSA C22.2 No. 8.

24. Add the following Subrules to Rule 4-004:

- (19) The ampacity of service conductors supplying enclosed fusible switches not exceeding 600 A shall be not less than the switch rating.
- (20) Notwithstanding Subrule (19), where the load can be determined under Section 8, the ampacity of service conductors supplying enclosed fusible switches rated



For Your Safety

over 100 A but not exceeding 600 A shall be not less than the load or 80% of the switch rating, whichever is greater.

- (21) The requirements of Subrules (19) and (20) shall also apply to the conductors on the load side of the main service switch or equivalent up to the first point of distribution or equivalent.
- (22) Subrules (19), (20), and (21) shall not apply to conductors supplying
 - (a) a single fixed load where the load is unlikely to be increased; or
 - (b) a motor load where the conductors are sized in accordance with Section 28.

25. Delete CE Code Rule 6-112 (2) and replace with the following:

- (2) The point of attachment of supply or consumer service conductors shall be not less than 4.5 m nor more than 9 m above sidewalk or grade level and shall be located such that the clearance of supply conductors at any point above finished grade shall be not less than the following:
 - (a) 4.5 m on properties accessible to pedestrians and passenger vehicles only; or
 - (b) 6 m on properties accessible to commercial and farm vehicles.

26. Delete CE Code Rule 6-200 (2) and replace with the following:

- (2) Where acceptable, or unless prohibited by a code or standard under a rule or by-law of the supply authority concerning the number of service boxes, more than one service box shall be permitted to be connected to a single consumer's service, provided that
 - (a) the subdivisions are made in a multiple or dual lug meter-mounting device rated at not more than 600 A and 150 V to ground;
 - (b) the meter-mounting device is located outdoors; and
 - (c) for other than consumer's services to residential occupancies, the ampere rating of the multiple meter-mounting device is not less than the sum of the ampere ratings of the service boxes supplied from the meter-mounting device.

27. Add Rule 10-004 as follows:

10-004 Special terminology

In this Section the following definition applies:

Effectively grounded metal structural frame of a building — a metal structural frame of a building with members (including columns and beams) that are permanently bonded to each other and to the main service grounding conductor or electrode in such a way as to satisfy the requirements of Rule 10-500.



28. Add Rule 10-206 (4) as follows:

- (4) Notwithstanding Rules 10-802 and 10-806, where an isolated system or circuit is required to be grounded, the grounding connection shall be permitted to be made to the effectively grounded metal structural frame of a building.

29. Delete CE Code Rule 12-000 (1)(b) and (d).

30. Add Rule 14-418 as follows:

14-418 Disconnecting Means

- (1) A single disconnecting means shall be provided either integral with or adjacent to the distribution equipment,
 - (a) within each unit of a multi-unit building, other than a dwelling unit;
 - (b) within each area common to more than one building, such as an underground parking area; or
 - (c) within each building when fed from another building.
- (2) Subrule (1) does not apply to circuits from part of fire alarm, fire protection, and emergency systems.

31. Delete CE Code Rule 16-222.

32. Delete CE Code Rule 24-000(2).

33. Delete CE Code Rule 26-744(4) and replace with the following:

- (4) A receptacle of CSA Configuration 14-50R, as shown in Diagram 1, shall be installed at a suitable location in every single dwelling and in every dwelling unit of an apartment or similar multi-dwelling building for supplying electric energy to an electric range.

34. Add Rules 26-744(9), (10), (11) and (12) as follows:

- (9) Where a wiring system intended to supply an electric clothes dryer is installed, it shall be connected to a receptacle as outlined in Subrule (3) at the load end and connected to the panelboard at the supply end.
- (10) Where a receptacle as required by Subrule (3) is installed, it shall be connected to the panelboard by a wiring system as specified in Section 12.



For Your Safety

- (11) The range receptacle referred to in Subrule (4) shall be connected to the panelboard by a wiring system as specified in Section 12 and shall have overcurrent protection as required by Section 14.
- (12) Notwithstanding Subrule (4), the range receptacle need not be installed in
 - (a) dwelling units where a built-in gas-fired or electric cook top or a built-in gas-fired or electric oven is installed;
 - (b) other than single dwellings where provision has been made for a gas range; or
 - (c) dwelling units where power from a supply authority is not available and the capacity of local generation is less than 6 kW.

35. Delete CE Code Section 54.

36. Delete CE Code Rule 56-106.

37. Delete CE Code Section 60.

38. Add Rule 68-000(2)(g):

- (g) splash pads.

39. Add the following definition to Rule 68-050:

Splash pad — an area designed for water play that is not intended to have standing water.

40. Add Section 75 as follows:

Section 75 — Installation of lines and wiring of buildings

75-000 Scope

- (1) This Section applies to
 - (a) installations of primary and secondary lines except for lines owned by a supply authority;
 - (b) poles and pole-mounted electrical equipment; and
 - (c) installation of electrical equipment in farm buildings and similar structures.
- (2) This Section supplements or amends the general requirements of this Code.



For Your Safety

75-002 Special terminology

In this Section, the following definitions apply:

ACSR — aluminum conductor, steel reinforced.

Classified — poles graded according to strength whereby the minimum circumferential dimensions are determined so that all poles of the same class, regardless of length, will withstand the same horizontal force applied 0.6 m from the top of the pole when supported 1.8 m from the butt end in accordance with CSA O15 series.

CMS — Central Metering System.

Distribution system — the system by which electrical power or energy is distributed to the receiving equipment and includes components such as primary line, secondary line, services, distribution transformers, distribution equipment, and other equipment of a similar nature.

Free-standing pole — a pole structure and base assembly that is installed with engineering direction without the use of guys.

Lines —

Primary line — a distribution system operating at more than 750 V but not more than 50 000 V phase-to-phase.

Secondary line — a distribution system operating at 750 V or less.

Neutral-supported cable — two or three insulated conductors and a bare neutral.

Open wire bus — a secondary line conductor with a weatherproof covering on the phase conductors and includes a bare neutral.

Penta — wood poles treated with pentachlorophenol.

Pole-mounted lighting systems — a system of luminaires, poles, sign luminaires, underpass illumination, cables, power supply equipment, control system, and associated materials required to provide illumination on a roadway or associated appurtenances on private premises.

Power conductor — a conductor that conveys electrical power or energy and is not part of a communication circuit.

Roadway lighting systems — a system of luminaires, poles, sign luminaires, underpass illumination, cables, power supply equipment, control system, and associated materials required to provide illumination on a roadway or associated appurtenances on a Municipal or a Provincial right of way.

75-004 General requirements

- (1) Every installation under this Section shall be inspected in accordance with Section 2 of this Code.
- (2) Where the work consists of the installation of a service, the contractor shall consult the supply authority as to the layout of the service and the location of the transformer and meter, regarding compliance with applicable codes or standards under a rule or by-law of the supply authority.



For Your Safety

- (3) Where the work consists of the installation of conductors over or under a railway, the contractor shall submit to the inspection department a plan of the crossing endorsed by the railway company with an approval of the work.
- (4) Where approval is required from the supply authority by this Rule, such approval shall be obtained prior to commencement of any work with respect to the installation.
- (5) Where a consumer desires to install the conductors of a primary or secondary line across a public road, the crossing shall not be made without written permission from both the supply authority and the authority having jurisdiction over the road and shall have the minimum clearance as specified in Rule 75-310(1).

A) Poles, guys, and framing equipment

75-200 Poles

All secondary line, primary line, and transformer poles shall be new, classified, and made of

- (a) wood;
- (b) steel;
- (c) concrete;
- (d) fibre-reinforced polymer; or
- (e) other acceptable material.

75-202 Equipment attached to poles

- (1) No electrical equipment shall be attached to the poles of a supply authority without permission of the supply authority.
- (2) Equipment mounted on a pole shall be mounted on the same 1/3 continuous pole circumference leaving the remaining 2/3 of the continuous pole circumferences clear for climbing purposes.
- (3) Stainless steel bands shall not be used as the sole support for electrical equipment installed on wooden poles.
- (4) Electrical equipment installed on metal or concrete poles shall be permitted to be supported by stainless steel strapping and buckles that shall have a minimum support strength of 4.5 kN.

75-204 Joint use of poles for communications circuits and power conductors

Power conductors and communication circuits shall not be carried on common poles unless written consent for the joint use of the poles is obtained from the supply authority and the operators of the communication circuits.

75-206 Wood poles

- (1) The pole "Species — Treatment" combinations listed in Table 102 are acceptable for new installations.



For Your Safety

- (2) Notwithstanding Rule 75-200, pressure-treated pine and butt-treated western cedar poles for new lines can be re-used provided that the poles are classified, are not more than 10 years old, have no visible signs of damage, and their re-use is lawful under Rule 2-030.
- (3) Wood poles shall adhere to the following requirements:
 - (a) a transformer pole shall be a minimum of class 5 and in accordance with the requirements of Table 103;
 - (b) a single-phase primary line pole or a secondary line pole shall be a minimum of class 7; or
 - (c) a three-phase primary line pole shall be a minimum of class 5.
- (4) Notwithstanding Rule 75-200, a used wood pole may be used on secondary lines only after its condition has been checked by the inspection department and before the pole is set in the ground.

75-208 Marking of wood poles

All wood poles shall have the following marking:

- (a) butt marking showing
 - (i) type of wood;
 - (ii) supplier's code or trademark; and
 - (iii) class and length;
- (b) side markings located above the groundline in accordance with Table 104; and
- (c) side marking that shall include
 - (i) treatment plant;
 - (ii) class and length;
 - (iii) type of wood;
 - (iv) last 2 numerals of year of treatment; and
 - (v) preservation code letter.

75-210 Steel poles set directly in soil

Steel poles set directly in soil are acceptable subject to compliance with Rules 75-212 through 75-224.

75-212 Grounding of steel poles

- (1) The steel pole shall be permitted to be used as the grounding electrode for equipment mounted on the pole where the steel pole is directly embedded in soil and the portion of the pole in contact with the soil is not coated with any non-metallic coating or covering and such an installation is in accordance with the manufacturer's recommendations.
- (2) Where a pole is used as the ground electrode for the transformer, the transformer shall be bonded to the pole and the neutral in accordance with Specifications 44 and 45.



For Your Safety

75-214 Guying of steel poles

- (1) Notwithstanding Rule 75-250, guys directly attached to steel poles need not have a guy insulator, and the attachment hardware shall be suitable for the poles.
- (2) The number and placing of guys, in addition to meeting the requirements of this Code shall be in accordance with the manufacturer's recommendations.
- (3) The baseplate and top cap recommended by the manufacturer for the poles shall be installed.
- (4) Clamps for the neutral conductor shall be a type designed for the poles.
- (5) Spool-type insulating supports shall not be permitted.
- (6) A bolt to guard against pole splitting at the top shall not be required.
- (7) The distance from top of the pole down to the top bolt for pole line hardware shall be permitted to be 10 cm rather than the 15 or 20 cm used for wood poles.
- (8) Pole mounts for rock shall not be permitted.
- (9) Swamp cribbing shall be permitted to be used only where permitted by and in accordance with the manufacturers' instructions.

75-216 Steel pole installations in known corrosive soils (see Appendix B)

Additional below-grade corrosion protection shall be required for steel poles set directly in soil where there is knowledge or a history of aggressive corrosion of steel or iron in the soil.

75-218 Steel pole requirements

- (1) The poles shall be manufactured in compliance with the designs used to assign classes and other applicable requirements in CSA C22.3 No. 1.
- (2) The poles shall be galvanized.
- (3) Evidence of compliance with Subrules (1) and (2) shall be included in a report from a certification organization or from a professional engineer.
- (4) Notwithstanding Rule 75-200, a used steel pole can be used on secondary lines only after it is authorized by the inspection department prior to being set in the ground.

75-220 Marking of steel poles

- (1) The poles shall be side marked above the ground line in accordance with Table 104, with manufacturer's code or trademark and with the last two digits of the year of manufacture, pole class, and length.
- (2) The pole class marking used for pole design loads shall have equivalency with the wood pole classes 1, 2, 3, 4, 5, and 6 as set out in CAN/CSA-O15, where the equivalency is based on the requirements for Grade 2 construction as defined in CSA C22.3 No. 1.

75-222 Insulators on steel poles

Insulators that may be mounted directly on grounded steel structures are specified in Table 100.



For Your Safety

75-224 Depth of setting of steel poles

Depth of setting for steel poles shall be as shown in Table 104.

75-228 Concrete poles

Installations of concrete poles shall be in accordance with Rules 75-232 through 75-238.

75-230 Insulators on concrete poles

Insulators that may be mounted directly on grounded concrete poles are specified in Table 100.

75-232 Grounding of concrete poles

- (1) Each pole shall be installed with a grounding stud and shall be connected to the system neutral or ground rod to provide grounding for the reinforcing bars.
- (2) The reinforcing bars shall not be considered as a ground electrode.

75-234 Concrete pole selection

- (1) Accepted pole classes shall be in accordance with the equivalencies in Table 101.
- (2) Notwithstanding Rule 75-200, a used concrete pole may be used on secondary lines only after its condition has been checked by the inspection department and before the pole is set in the ground.

75-236 Marking of concrete poles

The poles shall be side marked above the ground line in accordance with Table 104, with manufacturer's code or trademark, and with the last two digits of the year of manufacture, pole class, and length.

75-238 Depth of setting of concrete poles

Depth of setting for concrete poles shall be as shown in Table 104.

75-239 Fibre-reinforced polymer poles (see Appendix B)

- (1) Fibre-reinforced polymer poles shall be manufactured in accordance with ASCE Manual 104, Recommended Practice for Fibre-Reinforced Polymer Products for Overhead Utility Line Structures.
- (2) Fibre-reinforced polymer pole shall be side marked above the ground line in accordance with Table 104, with manufacturer's code or trademark, and with the last two digits of the year of manufacture, pole class, and length.

A) General

75-240 Length of poles

Subject to Rule 75-310,

- (a) every pole in a primary line shall be at least 12.2 m (40 ft) in length;
- (b) every pole in a secondary line shall be at least 9.2 m (30 ft) in length;



For Your Safety

- (c) notwithstanding Items (a) and (b), in case of rock pole mounts approved in accordance with Rule 75-242(6)(b), the above pole lengths shall be permitted to be reduced by 1.5 m; and
- (d) notwithstanding Item (a), lesser pole lengths shall be acceptable for stand alone transformer pole installations, provided that the vertical height of any live part is at least 7 m (23 ft) above grade level.

75-242 Setting of poles

- (1) Where a pole having a length shown in column 1 of Table 104 is set in earth, the butt end of the pole shall be buried to a depth at least that prescribed in column 2 of Table 104.
- (2) Where a pole having a length shown in column 1 of Table 104 is set in solid rock using a rock auger, the butt end of the pole shall be buried to a depth at least that shown in column 2 of Table 104, less
 - (a) 30 cm for fair rock and limestone; or
 - (b) 60 cm for solid rock, granite or massive limestone.
- (3) Where poles are installed on slopes or hillsides, the depth of the hole shall be measured from the lower side of the opening.
- (4) Corner and dead-end poles shall be offset away from anchor, or raked towards the anchor in accordance with Specifications 3 and 4.
- (5) Pole mounts are acceptable on rock, in accordance with Specification 5, when in accordance with a code or standard under a rule or by-law of the supply authority.
- (6) Where it is impossible to employ the above methods,
 - (a) poles shall be cribbed in accordance with
 - (i) Specification 6 — Swamp cribbing with steel culvert section for wood poles; or
 - (ii) Specification 7 — Swamp cribbing with steel culvert section for wood poles with butt of pole not reaching solid earth at normal setting depth.
 - (b) when bedrock is encountered, pole setting reduction using filled steel culverts as a partial substitute shall be permitted for normal soil setting depth, provided that
 - (i) the use of steel culverts is limited to situations where the lack of readily available equipment for rock removal (by blasting or drilling);
 - (ii) the number of steel culverts, when used, is limited to two adjacent pole locations; and
 - (iii) the installation is conducted in accordance with Specification 8.

75-244 Pole spans and framing

- (1) Poles used in secondary lines shall be placed not more than 40 m apart.
- (2) Subject to Subrule (3), poles used in primary lines shall be placed not more than 90 m apart.



For Your Safety

- (3) Poles used in primary lines shall be framed according to the following Specifications:
 - Specification 9 — Primary, 1-phase, 2.4 to 8 kV, maximum span 90 m.
 - Specification 10 — Primary, 1-phase, 2.4 to 16 kV, maximum span 90 m.
 - Specification 11 — Primary, 3-phase, 2.4/4.16 to 8.0/13.8 kV.
 - Specification 12 — Primary, 3-phase, 2.4/4.16 to 16/27.6 kV.
 - Specification 13 — Primary, 3-phase, line angles 4°–90°, 2.4/4.16 to 16/27.6 kV.
 - Specification 14 — Primary, 3-phase, crossarm, 2.4/4.16 to 16/27.6 kV.
 - Specification 15 — Primary, 3-phase, underbuilt, 2.4/4.16 to 16/27.6 kV.
 - Specification 16 — Primary, 3-phase, 44 kV.
 - Specification 17 — Primary, 3-phase, line angles 4°–90°, 44 kV.
 - Specification 18 — Primary, 3-phase, crossarm, 44 kV.

75-246 Anchors

- (1) Poles at dead ends or angles shall be anchored as follows:
 - (a) where a steel plate anchor is used, it shall be installed in the manner prescribed by Specification 19;
 - (b) where a log anchor is used, it shall be installed in the manner prescribed by Specification 20;
 - (c) where an expansion anchor is used, it shall be installed in the manner prescribed by Specification 21; or
 - (d) where a screw anchor is used, it shall be installed in the manner prescribed by Specification 22.
- (2) Where anchors are installed in
 - (a) solid rock, the anchors shall be installed in accordance with either Figure 1 or 2 of Specification 23; or
 - (b) shale or limestone, the anchors shall be installed in accordance with Figure 1 or 2 of Specification 24.
- (3) Power driven screw anchors shall be installed in accordance with the manufacturer's specifications.
- (4) All backfill associated with the installation of anchors shall be well tamped.

75-248 Guy wires and guards

- (1) Guy wires shall
 - (a) be of 7-strand steel;
 - (b) have a diameter of at least 9 mm; and
 - (c) be galvanized.
- (2) Arrangement of guys shall be in accordance with Specifications 25, 26, and 39.
- (3) Suitable guys shall be required for dead-ended temporary service that is mounted on a treated post and for spans greater than 10 m.
- (4) Notwithstanding Subrules (2) and (3), a guy is not required for dead-ended temporary service that is mounted on a pole and where the span does not exceed 10 m.



For Your Safety

- (5) Guy guards shall be installed at all locations.
- (6) The guy guard shall be made of plastic and shall provide good visual identification for public safety.
- (7) Where two or more guys are attached to one anchor, a guy guard shall be installed on the upper guy only.
- (8) Guys shall not be required for support of a free-standing terminal pole where the specific pole installation includes a design drawing for the pole and supporting base, and the design drawing shall be from the pole manufacturer or shall be signed by a professional engineer.

75-250 Strain insulator on pole guys

- (1) Every guy shall have a strain insulator installed in the manner prescribed in Specification 25, and pre-formed guy grips suitable for the purpose may be used instead of 3-bolt clamps.
- (2) A second strain insulator at a point below the point of possible contact of the conductor and guy wire shall be installed in accordance with Specification 25 where
 - (a) the guyed pole carries a transformer or a fused switch; and
 - (b) the breaking of a guy wire could cause a part of the guy wire below the strain insulator to fall against a conductor carried by the pole.

75-252 Anchoring for change of line direction

- (1) Arrangement of guys and anchoring for change of line direction shall be in accordance with Specification 26.
- (2) Arrangement of guys and anchoring for dead-end construction shall be in accordance with Specification 26.
- (3) Transformer poles fed from underground circuits with no overhead distribution shall have three down guys placed approximately 120° apart and attached below the transformer.
- (4) Subrule 3 does not apply to free-standing terminal poles.

75-254 Span guy construction

- (1) Where a span guy shall be installed, it shall be constructed in the manner prescribed in Specification 4.
- (2) Where the span between the guyed pole and stub pole crosses over or under conductors operating at a potential of more than 150 V to ground, a second strain insulator shall be installed in the span at a point between the power conductors and the guyed pole and not less than 2.5 m from the stub pole, in accordance with Specification 25.

75-256 Guys on poles

- (1) A guy wire shall be attached to the pole with an approved fitting shown in Item 1 of Specification 27 in the manner prescribed in Specification 3 and in such a way that



For Your Safety

there is no contact between the guy wire fitting or its mounting bolt and any ground wire on the pole.

- (2) Acceptable pre-formed guy grips may be used in place of the approved fitting mentioned in Subrule (1).
- (3) The back of an insulator through bolt shall not be used as an attachment point for guys.

75-258 Anchor distance from pole

The distance of an anchor from its pole shall be at least one-third the height of the pole above ground.

75-260 Hardware

All hardware shall be galvanized or corrosion resistant.

75-262 Crossarms

- (1) Crossarms, if made of wood shall
 - (a) be Douglas Fir, Western Larch, Western Hemlock, Yellow Cypress, Jack Pine, or Lodgepole Pine; and
 - (b) have dimensions in accordance with Specification 29 and be at least 120 mm wide and 95 mm thick.
- (2) Steel crossarms shall have dimensions in accordance with Specification 30.

75-264 Braces for crossarms on primary lines

- (1) All crossarms shall have two braces, each 864 mm in length.
- (2) One piece, "V"-shaped crossarm braces shall be permitted.
- (3) Notwithstanding Subrule (1), braces shall not be required if the crossarm is equipped with a mounting bracket designed to provide the equivalent support of braces.

75-266 Insulators

Insulators shall be selected in accordance with Specifications 31, 32, 33, or Table 100.

75-268 Warning signs

All poles carrying primary or secondary lines shall have the following warning sign: "Danger — Keep Off. If work on this pole or near wires is necessary, call a qualified person."

C) Primary and secondary line clearances and installations

75-302 Clearances between power conductors and communication circuits

- (1) Electrical equipment, power conductors, communication circuits, and equipment shall be constructed and maintained so as to create no undue hazard to previously installed facilities.



For Your Safety

- (2) Where power conductors and communication circuits are carried on separate parallel pole lines, such lines shall be spaced apart sufficient distance such that one line cannot fall upon the other line in the event of a pole breaking.
- (3) Where lines cross such that the conductors of one circuit may fall upon the conductors of another circuit, the power conductors shall be installed such that the clearance between the upper conductors at maximum sag and the lower conductors assumed to form a straight line between its points of support is at least in accordance with Specification 1, Item 4.
- (4) Where power conductors and communications circuits are carried on the same pole, the power conductors shall be installed such that the clearance between the upper conductors at maximum sag and the lower conductor complies with Specification 2.
- (5) Subrules (3) and (4) shall not apply to a service span from a pole to a building.

75-304 Location of conductors on primary lines

- (1) Where primary line conductors cross other conductors of lower voltage, the conductors of the circuit having the highest voltage shall be installed above such other conductors of lower voltage and shall have minimum clearances in accordance with Specification 1, Items 1 and 2.
- (2) The neutral conductor associated with primary line shall be located below the phase conductors and shall have minimum clearances in accordance with Specification 1, Item 2 and shall be a minimum of 200 mm below the transformer.

75-306 Clearances in service span

Where the voltage of power conductors is not more than 750 V, the distance between the power conductors and a communication drop-wire in the service span from a pole to a building shall be not less than 300 mm.

75-308 Span with secondary service line attached to buildings or mobile homes

- (1) The span of neutral-supported cables, types NS75 and NS90, shall be not more than 38 m from the point where the secondary service line is attached to a building to the nearest pole.
- (2) Notwithstanding Subrule (1), the span shall be not more than 10 m from the point where the secondary overhead service line is attached to a mobile home or similar structure to the nearest pole or other point of attachment.

75-310 Primary and secondary lines clearances

- (1) The poles that support the phase conductor of a primary line shall be so located and of such height as to afford a clearance of 7 m measured vertically between the conductors under maximum sag conditions and the ground.
- (2) Notwithstanding Subrule (1) for high voltage line installations where plans are submitted for examination to the inspection department, the clearances listed in Table 34 are acceptable.



For Your Safety

- (3) The primary line neutral shall be considered a secondary conductor and shall have the same minimum vertical clearance as specified in Subrule (4).
- (4) Conductors of a secondary line shall have a minimum 6 m measured vertically between the conductors under maximum sag conditions and the ground.

75-312 Clearances of conductors from buildings

- (1) An overhead primary line conductor shall be kept at least 3 m at maximum conductor swing measured horizontally from a building.
- (2) Primary line conductors shall not be installed over buildings unless the installation is lawful under Rule 2-030, and work shall not begin until the plans and specifications for the work are approved in accordance with Rule 2-010.
- (3) No building, mobile home or structure shall be placed or constructed within at least 3 m at maximum conductor swing measured horizontally from the nearest conductor of an overhead primary line.
- (4) Where the conductor swing is not known, a distance of 1.8 m shall be used.
- (5) An overhead secondary line conductor shall be kept at least 1 m measured horizontally from any building except where necessary to connect to the electrical wiring of a building.

75-314 Clearances for other structures

- (1) Notwithstanding Rule 36-110, conductors of a primary line shall
 - (a) not be located closer than 12 m measured horizontally from silos to the closest conductors, with the conductor at rest;
 - (b) not be located over wells from which pump rods may be lifted and come in contact with the conductors;
 - (c) have sufficient clearance from free-standing poles that support flood or area lighting, flagpoles, antennae, or other similar structures so as to permit the structure to fall in an arc, without touching the conductors at rest;
 - (d) not be located within 6 m, measured horizontally from wind-mills or similar structures to the closest conductor, with the conductor at rest; and
 - (e) have a minimum vertical clearance of 3.1 m above fencing at maximum sag.
- (2) Conductors of a secondary line shall not be installed closer than 1 m measured horizontally from structures.
- (3) The poles and equipment associated with a primary or secondary line shall be located and suitably protected so as to avoid the possibility of damage from contact with vehicles.

75-316 Overhead conductors

Primary line conductors shall be bare and not less than No. 2 AWG ACSR.

75-318 Sag between poles

Open wire bus, neutral-supported cable, and ACSR shall be installed so that the sag of the conductors between poles is determined by using Tables 105 or 107 to 112 whichever is



For Your Safety

applicable to the size and type of conductor being installed and with respect to applicable span and temperature.

75-320 Sag between pole and building

Open wire bus, neutral-supported cable, and ACSR shall be installed so that the sag of the conductors between a pole and a building is determined by using Tables 105 or 107 to 112, whichever is applicable to the size and type of conductor being installed and with respect to applicable span and temperature.

75-322 Compression connections

Compression connectors are required for all overhead current carrying connections.

75-324 Attachment of secondary service conductors

- (1) Secondary service conductors shall
 - (a) terminate on a dead-end rack of a type shown in Specification 35;
 - (b) be attached to a pole in accordance with either Specification 36, 37, 38 or 39; or
 - (c) be attached to the timber framing of a building by a one-wire rack such as shown in Figure 1 of Specification 35.
- (2) Where it is necessary to install an approved service mast to meet the requirements of Rule 6-112, the mast shall be attached to the building as shown in Specification 28 and guyed, if necessary, in accordance with the Note to Specification 28.

75-326 Tree trimming

- (1) The owner of a private line shall provide clearance to the line from trees and other forms of woody growth in compliance with a code or standard under a rule or by-law of the supply authority concerning tree trimming.
- (2) Where there is no applicable code or standard under a rule or by-law of the supply authority concerning tree trimming, all trees and woody growth adjacent to a line shall be trimmed so that minimum clearance to the nearest conductor horizontally at maximum conductor swing and vertically at a maximum sag shall be
 - (a) 1 m for secondary lines; and
 - (b) 4 m for primary lines.

75-328 Submarine power cable

Submarine power cables shall be manufactured to one of the following Standards:

- (a) ICEA S-95-658/NEMA WC70;
- (b) ICEA S-96-659/NEMA WC71;
- (c) ICEA S-93-639/NEMA WC74; or
- (d) CSA C68.10.

D) Grounding and bonding



For Your Safety

75-402 Crossarms

Where porcelain dead-end insulators are used, steel crossarms shall be connected to a ground electrode with a conductor of not less than

- (a) No. 4 AWG stranded bare copper conductor for 27.6 kV and below; and
- (b) No. 1/0 AWG stranded bare copper conductor for voltages greater than 27.6 kV.

75-404 Grounding overhead installations

Grounding for pole-mounted equipment, hardware, crossarms, and/or a system neutral shall be installed in accordance with Specification 34.

75-406 Grounding conductors

- (1) Metal guards or metal conduit shall not be used as protection for a grounding conductor in locations accessible to livestock.
- (2) A grounding conductor run underground to a ground electrode shall
 - (a) be buried in the earth to a depth not less than 250 mm below the ground level;
 - (b) not be located within 3 m of a doorway; and
 - (c) not be located in an area normally frequented by livestock.

75-408 Grounding the service box on a transformer pole

- (1) Where a service box is installed on a transformer pole and the supply authority owns the transformation,
 - (a) the pole-top equipment/system ground conductor and ground electrode shall be installed at the pole by the supply authority;
 - (b) the contractor shall install a grounding conductor, connect one end to the identified neutral conductor in the service box, bond it to the non-current carrying metal parts of the electrical equipment, and extend at least 500 mm of the ground conductor outside of the service equipment for connection to the supply authority ground conductor; and
 - (c) the supply authority shall connect the service ground conductor to the supply authority ground wire.
- (2) The neutral conductor shall be installed and connected in the service box.
- (3) The neutral conductor shall be installed with both the line and the load conductors on the service pole.
- (4) Where the transformation is privately owned, the owner shall supply and install all grounding and bonding.

75-410 Neutral voltage mitigation devices installed on transformer poles

- (1) The device shall be approved.
- (2) All grounding conductors shall be insulated (minimum 600 V) and shall be not less than No. 4 AWG copper.



For Your Safety

- (3) Each grounding conductor shall have mechanical protection up to the neutral voltage mitigation device in accordance with Specification 34.
- (4) Primary and secondary ground electrodes shall be spaced not less than 5 m apart.
- (5) A permanent warning sign shall be installed directly below the device and shall read: "WARNING — Primary and secondary grounding conductors shall be interconnected prior to disconnecting this device for service or removal" or the equivalent.

75-412 Multiple grounding on primary lines system neutral

- (1) The system neutral on primary distribution lines shall be multi-grounded.
- (2) The standard number of grounds per km of circuit shall be 4.
- (3) The neutral potential shall not exceed 10 V rms to a remote ground at any point under steady-state conditions.

E) Services

75-502 Guys on service masts

- (1) Where the distance from the upper support clamp on the service mast to the point of attachment exceeds 1.5 m, or where the span exceeds 30 m, or the weather loaded tension is known to exceed 270 kg (600 lbs), the mast shall be guyed in accordance with Specification 28.
- (2) Guy wires shall
 - (a) be of stranded steel;
 - (b) have a diameter of at least 6 mm (1/4 in); and
 - (c) be galvanized or corrosion resistant.

75-504 Service box installation

- (1) When metering equipment is installed outdoors, the midpoint of the meter shall be located 1750 ± 100 mm, from finished grade, in accordance with Specifications 28 and 40.
- (2) Where a service box is installed on a transformer pole, no equipment other than that shown in Specification 40 shall be placed on the pole, except that one temporary service may be attached in addition to the permanent service.
- (3) Service boxes shall not be installed on poles located on a public road.
- (4) The following requirements shall apply to the Central Metering System (CMS):
 - (a) a standard pole-mounted distribution transformer without a secondary breaker or pole-mounted switch shall be used to supply multi-building installations;
 - (b) the method of entry of conductors into a building shall be in accordance with Rules 6-206 and 6-302;
 - (c) each building shall have a main service box at point of entry;
 - (d) the service equipment shall be bonded to the neutral;
 - (e) a ground electrode shall be installed at each service box in accordance with Rule 10-700;

For Your Safety

- (f) new overhead yard wiring shall be
 - (i) neutral-supported cable with a minimum of No. 2 AWG aluminum, and when in parallel, shall comply with Rule 12-108; and
 - (ii) notwithstanding Item (i), open wire bus shall be permitted where circuit ampacity exceeds 200 A;
- (g) the minimum ampacity of overhead or underground conductors feeding more than one service or building shall be based on 80% of the sum of the ratings of all service boxes supplied;
- (h) transformer pole hardware and metering equipment shall be in accordance with Specifications 41, 42, and 43;
- (i) if metering is located on other than a transformer pole, the meter socket shall be connected to the ground electrode and the system neutral in accordance with Specification 34;
- (j) pole-top switches shall be installed to the following requirements:
 - (i) the switch shall be approved for the purpose;
 - (ii) the minimum rating of a transfer switch shall be equal to or greater than 80% of the sum of all service boxes supplied;
 - (iii) the minimum clearances on the pole shall be those shown on Specification 41;
 - (iv) underground services shall be in accordance with the requirements of Rule 6-300; and
 - (v) pole-top transfer switches used in conjunction with Central Metering Systems shall be installed in accordance with Specification 41;
- (k) all equipment mounted on a pole shall be mounted on the same 1/3 continuous pole circumference leaving the remaining 2/3 of the continuous pole circumference clear for climbing purposes; or
- (l) CMS-type service shall not have more than four subdivisions of the service extending from one pole.

F) Installations of electrical equipment

75-602 Pole-mounted luminaires

- (1) Where pole-mounted luminaires are installed on poles carrying the conductors of a primary line, the luminaire shall be at least 3 m below the primary conductors.
- (2) Where luminaires are installed on a pole, there shall be signs cautioning that high voltage is present and advising that lamp changing shall be done only by qualified persons.
- (3) Notwithstanding Subrule (1) where the supply authority owns the pole-mounted luminaires, the clearance requirement does not apply.
- (4) Where pole-mounted luminaires are controlled from more than one point by switches, each switch shall be wired and connected so that the identified (neutral) conductor runs directly to the luminaire(s) controlled by it.



For Your Safety

- (5) The identified conductor of the circuit supplying the pole-mounted luminaire shall be permitted to be connected to the neutral conductor of a feeder or subfeeder.
- (6) Each lighting circuit shall have adequate overcurrent protection, for example, a weatherproof in-line fuseholder assembly is acceptable for this purpose.
- (7) All non-current-carrying metal parts of a luminaire shall be bonded to ground in accordance with Section 10.

75-604 Roadway lighting systems

- (1) Roadway lighting systems shall be installed in accordance with Rule 2-024(3) and Rules 30-100 to 30-1036, except that Rule 30-1006(1) need not apply.
- (2) In-line fuseholders shall be acceptable to satisfy the requirements of Rules 30-1002 and 30-1008, for single luminaires fed from overhead distribution systems where a dedicated roadway lighting bus is not available.

75-606 Aerially supported cables

- (1) Overhead cables shall be neutral-supported cables of Type NS75 or Type NS90.
- (2) Individual conductors of the moisture-resistant, rubber-insulated type suitable for exposed wiring where exposed to the weather as specified in Table 10 and cabled together with a messenger cable, shall be
 - (a) stranded; and
 - (b) not less than No. 12 AWG copper or No. 10 AWG aluminium.

G) Farm buildings

75-702 Grounding/bonding in milking areas

- (1) Livestock waterers, wire mesh, grates, metallic water pipes, stanchions, water bowls, vacuum lines, grain feeders, gates, support posts, and other metals shall be bonded together by a separate stranded copper conductor not smaller than No. 6 AWG.
- (2) The metallic equipment bonded in Subrule (1) shall be grounded and connected to the system neutral ground at the distribution panel by a separate single-stranded copper conductor not smaller than No. 6 AWG.
- (3) In milking parlours, concrete floors shall have a No. 9 gauge wire mesh, dimensions 15 × 15 cm (6 × 6 in), and bonding and grounding shall comply with Subrules (1) and (2)

For Your Safety

Table 100
Minimum insulation on steel or concrete poles
(See Rules 75-222, 75-230, and 75-266.)

| System voltage | Insulator type | |
|--------------------------|--|---------------------------------|
| | Porcelain | Polymer |
| | Insulator class | |
| 2.4/4.16–8/13.8 kV | (ANSI) Pin insulator 55-5 *3 (ANSI) LP 57-1L and 57-1S *5 | (CEA) DS15 *1 (CEA) LP15 *2 |
| 14.4/24.9 and 16/27.6 kV | (ANSI) Pin insulator 56-3 *4 (ANSI) LP 57-2L and 57-2S *5 | (CEA) DS28 *1 (CEA) LP28M *2 |
| 44 kV | (ANSI) Pin insulator 56-5 *4 (ANSI) LP 57-5L and 57-5S *5 | (CEA) DS46 *1 (CEA) LP46M *2 |

ANSI — American National Standard Institute

*3 — C29.5

*4 — C29.6

*5 — C29.7

CEA — Canadian Electricity Association

*1 — LWIWG — 01

*2 — LWIWG — 02

Table 101
Concrete pole class equivalency
(See Rule 75-234.)

| Class | Equivalent class of wood poles |
|-------|--------------------------------|
| E | 4 |
| F | 3 |
| G | 2 |
| H | 1 |



For Your Safety

Table 102
Wood pole species and treatment combinations
(See Rule 75-206.)

| Treatment preservative | Acceptable wood pole species |
|--|--|
| Pentachlorophenol (PCP) CCA-PEG CCA-ET (oil) CCA ACQ | Coast Douglas fir Interior Douglas fir White spruce Red spruce Western larch Jack pine White pine Red pine Lodgepole pine South yellow pine* Ponderosa pine Western hemlock Alaska yellow cedar Western red cedar |
| CCA — WR | Red pine |
| Copper naphthenate | Coast Douglas fir Jack pine Red pine Lodgepole pine South yellow pine Western red cedar |

*Southern Yellow Pine — Penta, which shall have a minimum of .38 pcf (pounds per cubic foot) of treatment preservative level, be kiln dried, and be marked "SPP.38" and "KD".

Table 103
Pole limitations maximum transformer weight in kilograms
(See Rule 75-206.)

| Pole lengths, m (ft)* | Transformer mounting | Pole class | | | |
|--------------------------|-------------------------|------------|------|-----|-----|
| | | 2 | 3 | 4 | 5 |
| 12.2 (40) | Direct | — | 1022 | 613 | 386 |
| | Cluster | 1771 | 1339 | 840 | 604 |
| 13.7 (45) | Direct | 1249 | 749 | 498 | 318 |
| | Cluster | 1566 | 1067 | 766 | 545 |

*Lesser pole lengths are acceptable for stand alone transformer pole installations with no overhead lines attached, provided that the vertical height to any live part is at least 7 m (23 ft) above grade level.



For Your Safety

**Table 104
Depth of setting of poles in soil**

(See Rules 75-208, 75-220, 75-224, 75-236, 75-238, 75-239, and 75-242 and Appendix B.)

| Pole length, m (ft) | Minimum depth of pole (m) | Max. height of marking (m) above grade |
|------------------------|------------------------------|---|
| 9.2 (30) | 1.7 | 1.3 ± 0.05 |
| 10.7 (35) | 1.7 | 1.3 ± 0.05 |
| 12.2 (40) | 1.8 | 1.2 ± 0.05 |
| 13.7 (45) | 2.0 | 1.1 ± 0.05 |
| 15.2 (50) | 2.1 | 1.0 ± 0.05 |
| Col. 1 | Col. 2 | Col. 3 |

Note: As per CAN/CSA-015-1990.

**Table 105
Sag of neutral-supported cable
(ruling span — 30.0 m)**

(See Rules 75-318 and 75-320.)

| Temp. °C | Triplex: 2-No. 4 Poly. AL. 1-No. 4 Bare ACSR | | | | Triplex: 2-No. 2 Poly. AL. 1-No. 2 Bare ACSR | | | | Triplex: 2-No. 1/0 Poly. AL. 1-No. 1/0 Bare ACSR | | | |
|-------------|--|-----|-----|------|--|-----|-----|------|--|-----|------|------|
| | Span, m | | | | Span, m | | | | Span, m | | | |
| | 15 | 23 | 30 | 38 | 15 | 23 | 30 | 38 | 15 | 23 | 30 | 38 |
| | Sag, mm | | | | Sag, mm | | | | Sag, mm | | | |
| -29 | 127 | 279 | 508 | 787 | 203 | 432 | 762 | 1194 | 254 | 584 | 1016 | 1575 |
| -18 | 152 | 330 | 559 | 838 | 203 | 457 | 813 | 1270 | 279 | 584 | 1041 | 1626 |
| 0 | 152 | 356 | 635 | 914 | 229 | 483 | 864 | 1346 | 279 | 610 | 1092 | 1702 |
| 16 | 178 | 406 | 711 | 1118 | 229 | 533 | 940 | 1473 | 279 | 635 | 1143 | 1778 |
| 32 | 203 | 432 | 762 | 1194 | 254 | 559 | 991 | 1549 | 305 | 660 | 1168 | 1829 |

(Continued)

For Your Safety

Table 105 (Concluded)

| Temp. °C | Triplex: 2-No. 3/0 Poly. AL. 1-No. 1/0 Bare ACSR | | | | Triplex: 2-No. 4/0 Poly. AL. 1-No. 3/0 Bare ACSR | | | |
|-------------|--|-----|------|------|--|-----|------|------|
| | Span, m | | | | Span, m | | | |
| | 15 | 23 | 30 | 38 | 15 | 23 | 30 | 38 |
| | Sag, mm | | | | Sag, mm | | | |
| -29 | 305 | 686 | 1194 | 1880 | 406 | 889 | 1600 | 2489 |
| -18 | 305 | 686 | 1219 | 1905 | 406 | 914 | 1626 | 2540 |
| 0 | 305 | 711 | 1245 | 1956 | 406 | 940 | 1651 | 2591 |
| 16 | 330 | 711 | 1270 | 1981 | 432 | 940 | 1676 | 2616 |
| 32 | 330 | 737 | 1321 | 2057 | 432 | 965 | 1727 | 2692 |

Ruling span formula:

Ruling span = average span + 2/3 (maximum span — average span)

Table 106 — Deleted

For Your Safety

Table 107
Sags and tensions for #2 ACSR (6/1) with 60 m (200 ft) ruling span
(See Rules 75-318 and 75-320.)

| Initial sags and tensions for stringing | | | | | | | | | | | | |
|---|---------|------|------|------|------|------|------|------|-----|---------|-------|--|
| Ambient temperature | Span | | | | | | | | | Tension | | |
| | 40 m | 45 m | 50 m | 55 m | 60 m | 65 m | 70 m | 75 m | lb | kN | % RTS | |
| | Sag, cm | | | | | | | | | | | |
| -20 °C | 21 | 27 | 33 | 40 | 48 | 56 | 65 | 75 | 274 | 1.2 | 9.8 | |
| -10 °C | 27 | 34 | 42 | 51 | 61 | 72 | 83 | 95 | 221 | 1.0 | 7.9 | |
| 0 °C | 33 | 42 | 51 | 62 | 74 | 87 | 101 | 116 | 184 | 0.8 | 6.6 | |
| 10 °C | 37 | 47 | 58 | 71 | 84 | 99 | 114 | 131 | 158 | 0.7 | 5.7 | |
| 20 °C | 43 | 55 | 67 | 82 | 97 | 114 | 132 | 152 | 140 | 0.6 | 5.0 | |
| 30 °C | 48 | 60 | 74 | 90 | 107 | 126 | 146 | 167 | 126 | 0.6 | 4.5 | |

| Final sags and tensions for design | | | | | | | | | | | | | |
|------------------------------------|------------------------|---------|---------|------|------|------|------|------|------|------|---------|-----|-------|
| Loading condition | | | Span | | | | | | | | Tension | | |
| Cond. temp. | Wind, N/m ² | Ice, mm | 40 m | 45 m | 50 m | 55 m | 60 m | 65 m | 70 m | 75 m | lb | kN | % RTS |
| | | | Sag, cm | | | | | | | | | | |
| -20 °C | 400 | 12.5 | 64 | 82 | 101 | 122 | 145 | 170 | 197 | 227 | 1090 | 4.8 | 39.1 |
| 30 °C | 0 | 0 | 55 | 70 | 86 | 104 | 124 | 146 | 169 | 194 | 109 | 0.5 | 3.9 |
| 50 °C | 0 | 0 | 63 | 80 | 99 | 119 | 142 | 167 | 193 | 222 | 95 | 0.4 | 3.4 |
| 100 °C | 0 | 0 | 80 | 101 | 125 | 151 | 180 | 211 | 245 | 281 | 75 | 0.3 | 2.7 |



For Your Safety

Table 108
Sags and tensions for #2 ACSR (6/1) with 75 m (250 ft) ruling span
(See Rules 75-318 and 75-320.)

| Initial sags and tensions for stringing | | | | | | | | | | | |
|---|---------|------|------|------|------|------|------|------|-----|---------|------|
| Ambient temperature | Span | | | | | | | | | Tension | |
| | 55 m | 60 m | 65 m | 70 m | 75 m | 80 m | 85 m | 90 m | | | |
| | Sag, cm | | | | | | | | | lb | kN |
| -20 °C | 34 | 41 | 48 | 56 | 64 | 73 | 82 | 92 | 326 | 1.4 | 11.7 |
| -10 °C | 42 | 50 | 59 | 68 | 78 | 89 | 100 | 112 | 271 | 1.2 | 9.7 |
| 0 °C | 49 | 58 | 68 | 79 | 91 | 104 | 117 | 131 | 229 | 1 | 8.2 |
| 10 °C | 58 | 68 | 80 | 93 | 107 | 122 | 137 | 154 | 199 | 0.9 | 7.1 |
| 20 °C | 64 | 76 | 89 | 104 | 119 | 135 | 153 | 171 | 176 | 0.8 | 6.3 |
| 30 °C | 71 | 84 | 99 | 115 | 132 | 150 | 170 | 190 | 159 | 0.7 | 5.7 |

| Final sags and tensions for design | | | | | | | | | | | | | |
|------------------------------------|------------------------|---------|---------|------|------|------|------|------|------|------|---------|-----|-------|
| Loading condition | | | Span | | | | | | | | Tension | | |
| Cond. temp. | Wind, N/m ² | Ice, mm | 55 m | 60 m | 65 m | 70 m | 75 m | 80 m | 85 m | 90 m | | | |
| | | | Sag, cm | | | | | | | | lb | kN | % RTS |
| -20 °C | 400 | 12.5 | 105 | 125 | 147 | 171 | 196 | 223 | 252 | 282 | 1270 | 5.6 | 45.5 |
| 30 °C | 0 | 0 | 84 | 100 | 118 | 137 | 157 | 179 | 202 | 226 | 134 | 0.6 | 4.8 |
| 50 °C | 0 | 0 | 97 | 115 | 135 | 157 | 180 | 205 | 231 | 259 | 118 | 0.5 | 4.2 |
| 100 °C | 0 | 0 | 122 | 145 | 170 | 197 | 226 | 257 | 290 | 325 | 93 | 0.4 | 3.3 |



For Your Safety

Table 109
Sags and tensions for #1/0 ACSR (6/1)
with 60 m (200 ft) ruling span
(See Rules 75-318 and 75-320.)

| Initial sags and tensions for stringing | | | | | | | | | | | |
|---|---------|------|------|------|------|------|------|------|---------|-----|-------|
| Ambient temperature | Span | | | | | | | | Tension | | |
| | 40 m | 45 m | 50 m | 55 m | 60 m | 65 m | 70 m | 75 m | | | |
| | Sag, cm | | | | | | | | lb | kN | % RTS |
| -20 °C | 23 | 29 | 35 | 43 | 51 | 60 | 69 | 80 | 426 | 1.9 | 10 |
| -10 °C | 27 | 34 | 42 | 51 | 61 | 72 | 83 | 95 | 345 | 1.5 | 8.1 |
| 0 °C | 33 | 42 | 51 | 62 | 74 | 87 | 101 | 116 | 288 | 1.3 | 6.7 |
| 10 °C | 38 | 48 | 60 | 72 | 86 | 101 | 117 | 134 | 249 | 1.1 | 5.8 |
| 20 °C | 43 | 55 | 67 | 82 | 97 | 114 | 132 | 152 | 220 | 1 | 5.1 |
| 30 °C | 48 | 61 | 76 | 92 | 109 | 128 | 147 | 170 | 198 | 0.9 | 4.6 |

| Final sags and tensions for design | | | | | | | | | | | | | |
|------------------------------------|------------------------|---------|---------|------|------|------|------|------|------|------|---------|-----|-------|
| Loading condition | | | Span | | | | | | | | Tension | | |
| Cond. temp. | Wind, N/m ² | Ice, mm | 40 m | 45 m | 50 m | 55 m | 60 m | 65 m | 70 m | 75 m | | | |
| | | | Sag, cm | | | | | | | | lb | kN | % RTS |
| -20 °C | 400 | 12.5 | 56 | 71 | 88 | 107 | 127 | 149 | 173 | 198 | 1366 | 6 | 31.9 |
| 30 °C | 0 | 0 | 54 | 69 | 85 | 103 | 122 | 143 | 166 | 191 | 176 | 0.8 | 6.3 |
| 50 °C | 0 | 0 | 63 | 80 | 99 | 119 | 142 | 167 | 193 | 222 | 142 | 0.6 | 5.8 |
| 100 °C | 0 | 0 | 80 | 101 | 125 | 151 | 180 | 211 | 245 | 281 | 120 | 0.5 | 4.3 |



For Your Safety

Table 110
Sags and tensions for #1/0 ACSR (6/1)
with 75 m (250 ft) ruling span
(See Rules 75-318 and 75-320.)

| Initial sags and tensions for stringing | | | | | | | | | | | |
|---|---------|------|------|------|------|------|------|------|-----|---------|-----|
| Ambient temperature | Span | | | | | | | | | Tension | |
| | 55 m | 60 m | 65 m | 70 m | 75 m | 80 m | 85 m | 90 m | | | |
| | Sag, cm | | | | | | | | | lb | kN |
| -20 °C | 35 | 42 | 50 | 57 | 66 | 75 | 85 | 95 | 513 | 2.3 | 12 |
| -10 °C | 42 | 50 | 59 | 68 | 78 | 89 | 100 | 112 | 426 | 1.9 | 10 |
| 0 °C | 51 | 60 | 71 | 82 | 94 | 107 | 121 | 135 | 360 | 1.9 | 8.4 |
| 10 °C | 58 | 68 | 80 | 93 | 107 | 122 | 137 | 154 | 313 | 1.4 | 7.3 |
| 20 °C | 64 | 76 | 89 | 104 | 119 | 135 | 153 | 171 | 278 | 1.2 | 6.5 |
| 30 °C | 73 | 86 | 101 | 118 | 135 | 154 | 173 | 194 | 251 | 1.1 | 5.9 |

| Final sags and tensions for design | | | | | | | | | | | | | |
|------------------------------------|------------------------|---------|---------|------|------|------|------|------|------|------|---------|-----|-------|
| Loading condition | | | Span | | | | | | | | Tension | | |
| Cond. temp. | Wind, N/m ² | Ice, mm | 55 m | 60 m | 65 m | 70 m | 75 m | 80 m | 85 m | 90 m | | | |
| | | | Sag, cm | | | | | | | | lb | kN | % RTS |
| -20 °C | 400 | 12.5 | 91 | 109 | 128 | 148 | 170 | 193 | 218 | 245 | 1596 | 7 | 37.3 |
| 30 °C | 0 | 0 | 82 | 97 | 114 | 132 | 152 | 173 | 195 | 219 | 219 | 1 | 5.1 |
| 50 °C | 0 | 0 | 94 | 112 | 131 | 152 | 175 | 199 | 225 | 252 | 191 | 0.8 | 4.5 |
| 100 °C | 0 | 0 | 120 | 143 | 168 | 194 | 223 | 254 | 286 | 321 | 150 | 0.7 | 3.5 |



For Your Safety

Table 111
Sags and tensions for #3/0 ACSR (6/1)
with 60 m (200 ft) ruling span
(See Rules 75-318 and 75-320.)

| Initial sags and tensions for stringing | | | | | | | | | | | |
|---|---------|------|------|------|------|------|------|------|-----|---------|------|
| Ambient temperature | Span | | | | | | | | | Tension | |
| | 40 m | 45 m | 50 m | 55 m | 60 m | 65 m | 70 m | 75 m | | | |
| | Sag, cm | | | | | | | | | lb | kN |
| -20 °C | 21 | 27 | 33 | 40 | 51 | 56 | 65 | 75 | 686 | 1.2 | 10.3 |
| -10 °C | 27 | 34 | 42 | 51 | 61 | 72 | 83 | 95 | 554 | 1 | 8.3 |
| 0 °C | 33 | 42 | 51 | 62 | 74 | 87 | 101 | 116 | 462 | 0.8 | 6.9 |
| 10 °C | 37 | 47 | 58 | 71 | 86 | 99 | 114 | 131 | 398 | 0.7 | 5.9 |
| 20 °C | 43 | 55 | 67 | 82 | 96 | 114 | 132 | 152 | 351 | 0.6 | 5.3 |
| 30 °C | 48 | 60 | 74 | 90 | 107 | 126 | 146 | 167 | 317 | 0.6 | 4.8 |

| Final sags and tensions for design | | | | | | | | | | | | | |
|------------------------------------|------------------------|---------|---------|------|------|------|------|------|------|------|---------|-----|-------|
| Loading condition | | | Span | | | | | | | | Tension | | |
| Cond. temp. | Wind, N/m ² | Ice, mm | 40 m | 45 m | 50 m | 55 m | 60 m | 65 m | 70 m | 75 m | | | |
| | | | Sag, cm | | | | | | | | lb | kN | % RTS |
| -20 °C | 400 | 12.5 | 50 | 63 | 78 | 94 | 112 | 131 | 152 | 175 | 1756 | 7.7 | 26.3 |
| 30 °C | 0 | 0 | 54 | 69 | 85 | 103 | 122 | 143 | 166 | 191 | 282 | 1.3 | 4.2 |
| 50 °C | 0 | 0 | 61 | 77 | 95 | 115 | 137 | 161 | 186 | 214 | 247 | 1.1 | 3.7 |
| 100 °C | 0 | 0 | 79 | 100 | 124 | 150 | 178 | 209 | 242 | 278 | 192 | 0.8 | 2.9 |



For Your Safety

Table 112
Sags and tensions for #3/0 ACSR (6/1)
with 75 m (250 ft) ruling span
(See Rules 75-318 and 75-320.)

| Initial sags and tensions for stringing | | | | | | | | | | | |
|---|---------|------|------|------|------|------|------|------|---------|-----|-------|
| Ambient temperature | Span | | | | | | | | Tension | | |
| | 55 m | 60 m | 65 m | 70 m | 75 m | 80 m | 85 m | 90 m | | | |
| | Sag, cm | | | | | | | | lb | kN | % RTS |
| -20 °C | 35 | 42 | 50 | 57 | 66 | 75 | 85 | 95 | 810 | 3.6 | 12.1 |
| -10 °C | 42 | 51 | 59 | 69 | 79 | 90 | 101 | 114 | 672 | 3 | 10.1 |
| 0 °C | 51 | 60 | 71 | 82 | 94 | 107 | 121 | 135 | 570 | 2.5 | 8.5 |
| 10 °C | 58 | 68 | 80 | 93 | 107 | 122 | 137 | 154 | 495 | 2.2 | 7.4 |
| 20 °C | 67 | 79 | 93 | 108 | 124 | 141 | 159 | 179 | 440 | 1.9 | 6.6 |
| 30 °C | 73 | 86 | 101 | 118 | 135 | 154 | 173 | 194 | 398 | 1.7 | 6 |

| Final sags and tensions for design | | | | | | | | | | | | | |
|------------------------------------|------------------------|---------|---------|------|------|------|------|------|------|------|---------|-----|-------|
| Loading condition | | | Span | | | | | | | | Tension | | |
| Cond. temp. | Wind, N/m ² | Ice, mm | 55 m | 60 m | 65 m | 70 m | 75 m | 80 m | 85 m | 90 m | | | |
| | | | Sag, cm | | | | | | | | lb | kN | % RTS |
| -20 °C | 400 | 12.5 | 81 | 96 | 113 | 131 | 150 | 177 | 193 | 216 | 2046 | 9 | 30.6 |
| 30 °C | 0 | 0 | 82 | 97 | 114 | 132 | 152 | 173 | 195 | 219 | 352 | 1.6 | 5.3 |
| 50 °C | 0 | 0 | 93 | 111 | 130 | 151 | 173 | 197 | 222 | 249 | 307 | 1.4 | 4.6 |
| 100 °C | 0 | 0 | 119 | 141 | 166 | 193 | 221 | 251 | 284 | 318 | 240 | 1.1 | 3.6 |

Table 113
(left intentionally blank)

For Your Safety

Table 114
Table of crib heights for wood pole in swamp
(See Specifications 6 and 7.)

| Crib heights | | | | | | | |
|-----------------------|---|--------------|--------------|---------------|---------------|---------------|--|
| Pole height in m (ft) | Setting "A" butt of pole resting on or penetrating at normal setting depth | | | | | | Setting "B" butt of pole not reaching solid earth at normal setting earth |
| | Depth of penetration | | | | | | |
| | 30 cm (1 ft) | 60 cm (2 ft) | 90 cm (3 ft) | 120 cm (4 ft) | 150 cm (5 ft) | 180 cm (6 ft) | |
| | Height of crib in cm (ft) | | | | | | |
| 12.2 (40) | 120 (4) | 90 (3) | 60 (2) | 60 (2) | * | * | 120 (4) |
| 13.7 (45) | 120 (4) | 90 (3) | 60 (2) | 60 (2) | * | * | 120 (4) |
| 15.2 (50) | 137 (4.5) | 106 (3.5) | 76 (2.5) | 60 (2) | 60 (2) | * | 137 (4.5) |
| 16.7 (55) | 150 (5) | 120 (4) | 90 (3) | 60 (2) | 60 (2) | * | 150 (5) |
| 18.2 (60) | 167 (5.5) | 137 (4.5) | 106 (3.5) | 76 (2.5) | 60 (2) | * | 167 (5.5) |
| 19.8 (65) | 167 (5.5) | 137 (4.5) | 106 (3.5) | 76 (2.5) | 60 (2) | * | 167 (5.5) |
| 21.3 (70) | 180 (6) | 150 (5) | 120 (4) | 90 (3) | 60 (2) | * | 180 (6) |
| 22.8 (75) | 180 (6) | 150 (5) | 120 (4) | 90 (3) | 60 (2) | * | 180 (6) |
| 24.3 (80) | 198 (6.5) | 167 (5.5) | 137 (4.5) | 106 (3.5) | 76 (2.5) | 60 (2) | 198 (6.5) |

Note: Minimum height of crib for any condition shall be 60 cm (2 ft).



For Your Safety

41. Add a note to Appendix B, Rule 2-010 as follows:

Rule 2-010

The intent is to have the submitter file with the inspection department complete wiring plans and specifications relating to the proposed work,

- (a) before any request for proposal or other document inviting tenders, bids or quotations for work on the installation; or
- (b) within the time specified by the inspection department.

Proceeding with the job to the energization point without prior approval is done solely at the contractor's risk. Essential information must be supplied as specified by the Inspection Department.

42. Delete the CE Code Appendix B note to Rule 16- 222 (1) (a)

Delete the CE Code Appendix B note to Rule 16- 222 (2)

43. Delete the CE Code Appendix B note to Section 54

44. Delete the CE Code Appendix B note to Section 60

45. Add a note to Appendix B, Rule 75-216 as follows:

Rule 75-216

For situations where aggressive corrosion exists, the steel pole manufacturer shall be consulted for appropriate additional below-grade corrosion protection such as polyurethane coatings or other proven methods. Where the embedded section of a steel pole is fully coated, proper grounding can be achieved by utilizing the threaded insert provided above the groundline on the pole to connect to a driven ground rod.

46. Add a note to Appendix B, Rule 75-234 as follows:

Concrete poles are graded according to strength in alphabetical sequence and strength: with pole strength increasing in alphabetical progression. The sizes of poles in these categories are so arranged that all poles of the same class, regardless of length, will resist the same horizontal force applied 60 cm (2 ft) from the top of the pole when supported 180 cm (6 ft) from the butt.

47. Add a note to Appendix B, Rule 75-239 as follows:

Rule 75-239

Reference publication:

ASCE (American Society of Civil Engineers)



For Your Safety

Manual 104-2003, Recommended Practice for Fiber-Reinforced Polymer Products For Overhead Utility Line Structures, as referenced in CSA C22.3 No. 1.

**48. Add a note to Appendix B, Rule 75-702 as follows:
Rule 75-702**

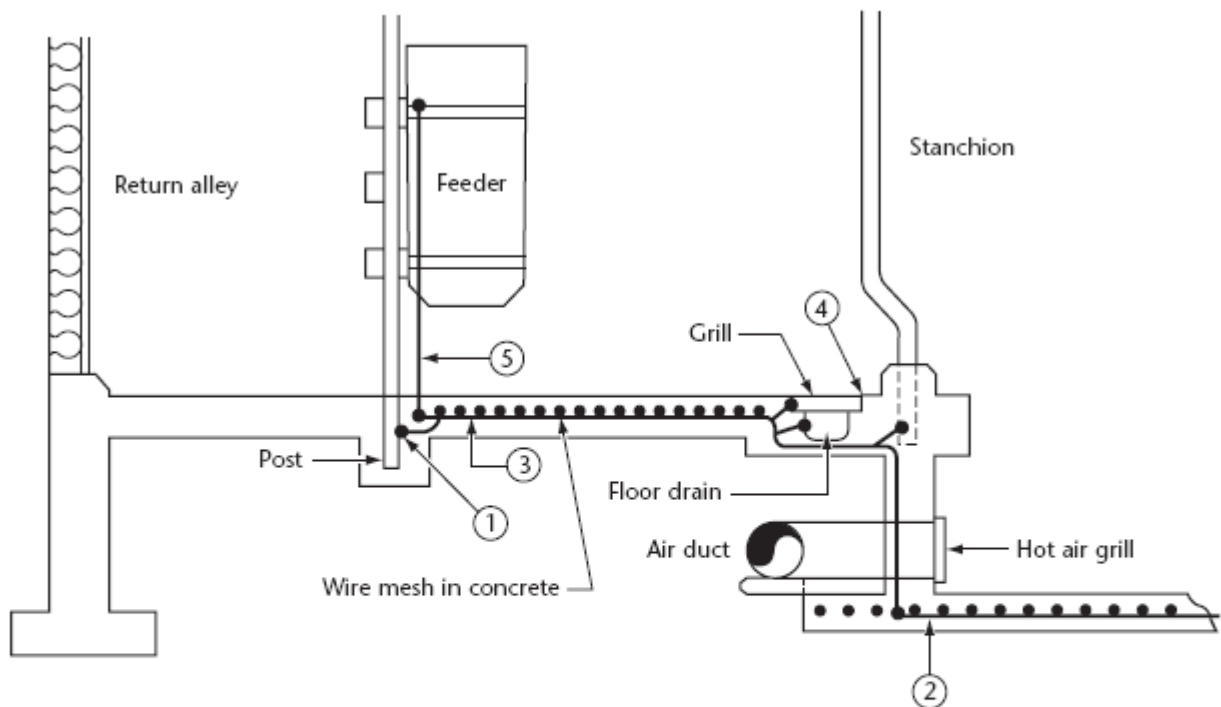

Notes:

- (1) All metal parts shall be bonded (including stanchion gates, drawbridges, and support posts).
- (2) No. 6 copper wire in parlour floor shall be bonded to No. 6 copper wire in pit at both ends and both sides.
- (3) No. 6 copper ground wire shall be bonded to No. 9 wire mesh, dimensions 15 × 15 cm (6 × 6 in), in concrete floor at 3 m (10 ft) intervals.
- (4) Angle iron grate supports for floor drains shall be bonded at both ends of parlour and both sides of grate.
- (5) See Detail 1.
- (6) For new and reconditioned existing parlours, wire mesh shall have a concrete cover of 75 mm (3 in).



For Your Safety

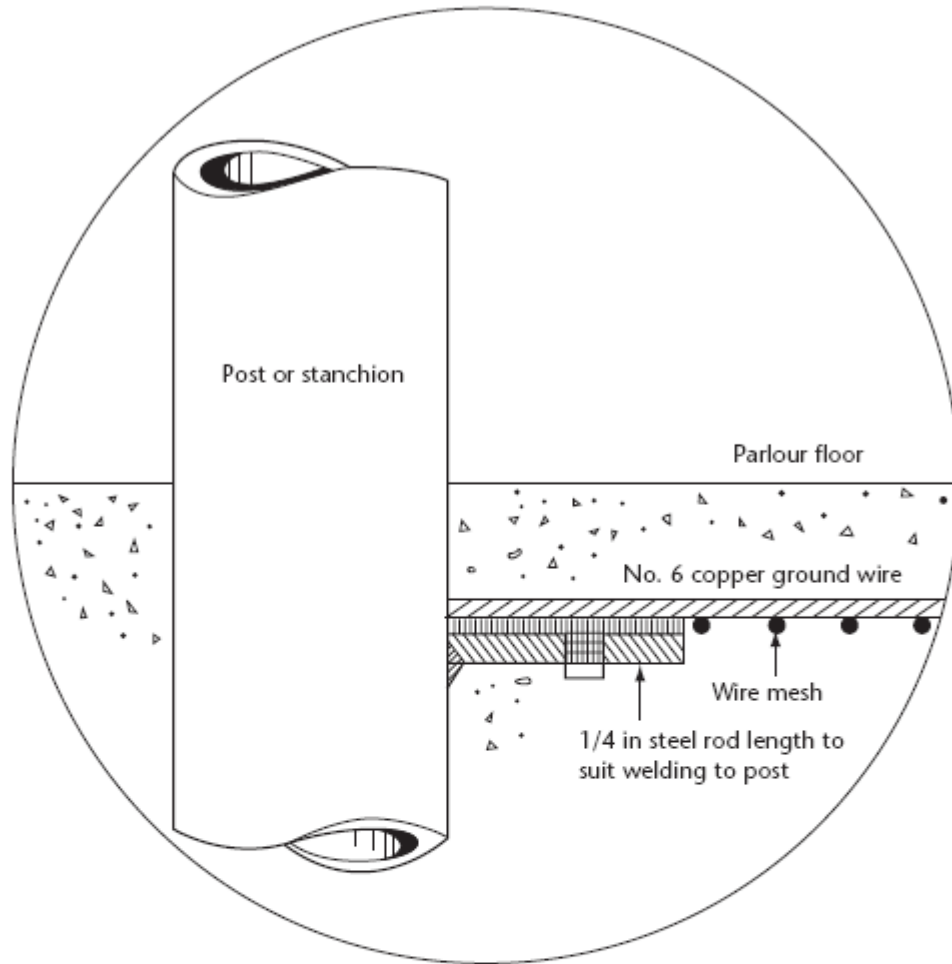

Wire mesh, ground wire, and 1/4 in steel rod shall all be welded to ensure circuit continuity.

1/4 in round steel rod shall be welded to feeder — down to mesh.

1/4 in rod, mesh, and No. 6 copper ground wire shall be welded together, 2 per side.

Detail 1



For Your Safety

Grounding/bonding in milking areas

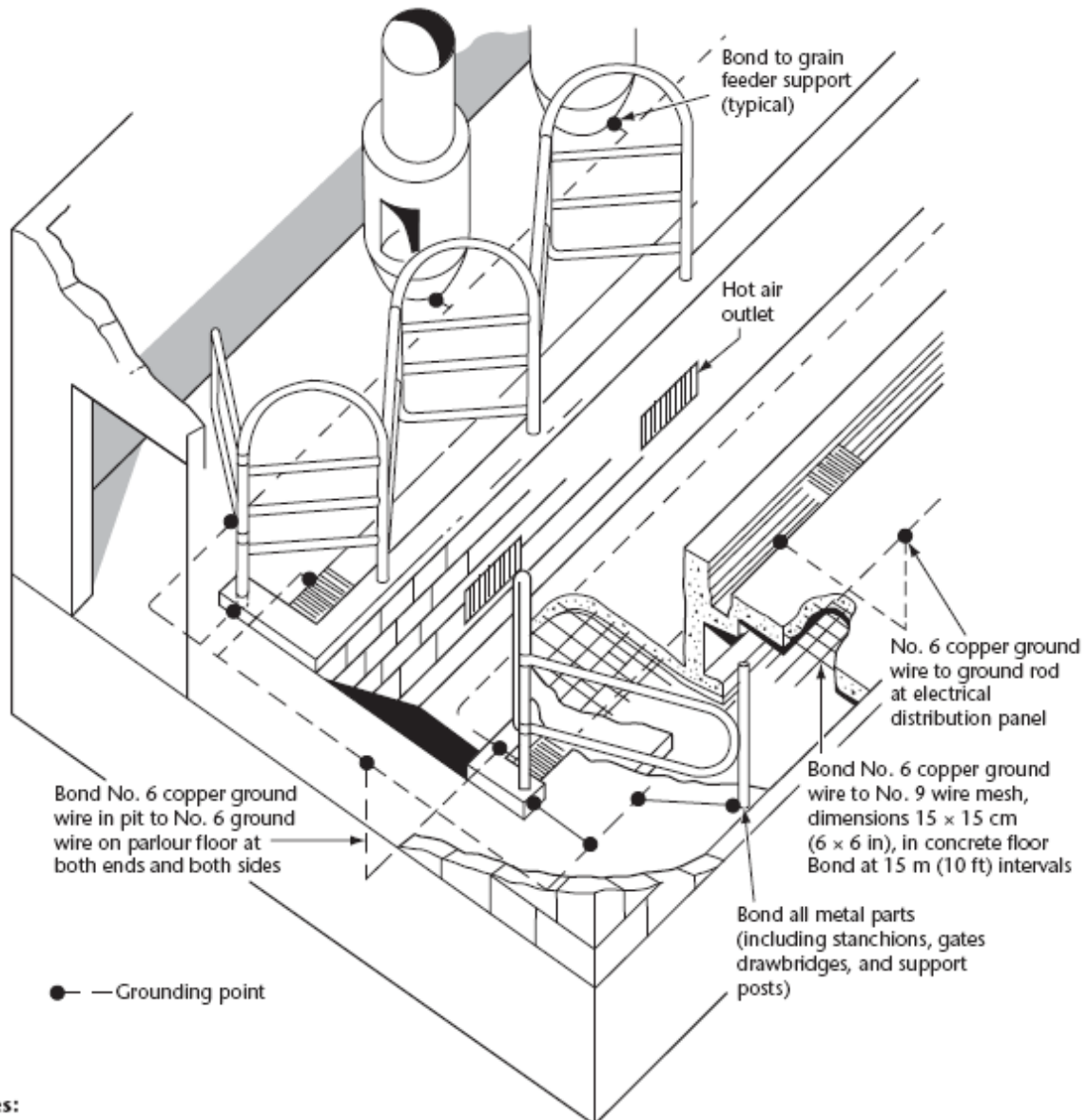

Notes:

- (1) Minimum size of ground wire shall be No. 6 copper.
- (2) Wire mesh shall be No. 9 gauge, dimensions 15 × 15 cm (6 × 6 in).
- (3) Wire mesh shall be bonded to ground wire at maximum intervals of 3 m (10 ft).
- (4) All steel posts, gate posts, support posts, feeder brackets, etc., shall be bonded to ground wire.
- (5) Angle iron grate supports for floor drains shall be bonded at both ends of parlour and both sides of grate.
- (6) Ground loop on floor of pit shall be connected to ground loop on floor parlour at both ends and both sides.
- (7) Grounding conductor size is given in American wire gauge.
- (8) For new and reconditioned existing parlours, wire mesh shall have concrete cover of 75 mm (3 in).



For Your Safety

49. Add Specifications:

- 1 Minimum vertical clearances between wires or conductors crossing in-span
- 2 Minimum vertical clearances in-span and separation at pole between supply and communication conductors
- 3 Down-guy(s) and offset
- 4 Span and anchor guy
- 5 Pole mounts for rock
- 6 Swamp cribbing with steel culvert section for wood poles
- 7 Swamp cribbing with steel culvert section for wood poles
- 8 Depth of pole setting reduction using steel culvert supports
- 9.1 Primary 1-phase tangent (pin insulator) 1-phase, 2.4 to 8.0 kV, maximum span 90 m (300 ft)
- 9.2 Primary 1-phase line angle 4° to 15° (pin insulator) 1-phase, 2.4 to 8.0 kV, maximum span 90 m (300 ft)
- 10.1 Primary 1-phase tangent (LP insulator) 1-phase, 2.4 to 16 kV, maximum span 90 m (300 ft)
- 10.2 Primary 1-phase line angle 4° to 15° (LP insulator) 1-phase, 2.4 to 16 kV, maximum span 90 m (300 ft)
- 10.3 Primary 1-phase line angle 16° to 60° 1-phase, 2.4 to 16 kV, maximum span 90 m (300 ft)
- 10.4 Primary 1-phase line angle 61° to 90° 1-phase, 2.4 to 16 kV, maximum span 90 m (300 ft)
- 10.5 Primary 1-phase dead-end 1-phase, 2.4 to 16 kV, maximum span 90 m (300 ft)
- 11.1 Primary 3-phase, underbuilt, line angle 4° to 15° crossarm (pin insulator) 3-phase, 2.4/4.16 to 8.0/13.8 kV, maximum span 60 m (200 ft)
- 11.2 Primary 3-phase, line angle 4° to 15° crossarm (pin insulator) 3-phase, 2.4/4.16 to 8.0/13.8 kV
- 11.3 Primary 3-phase, underbuilt tangent crossarm (pin insulator) 3-phase, 2.4/4.16 to 8.0/13.8 kV, maximum span 60 m (200 ft)
- 11.4 Primary 3-phase, tangent, crossarm (pin insulator) 3-phase, 2.4/4.16 to 8.0/13.8 kV
- 12.1 Primary 3-phase, tangent 3-phase, 2.4/4.16 to 16/27.6 kV
- 12.2 Primary 3-phase dead-end vertical 3-phase, 2.4/4.16 to 16/27.6 kV
- 12.3 Primary 3-phase tree framing 3-phase, 2.4/4.16 to 16/27.6 kV
- 13.1 Primary 3-phase line angle 4° to 15° 3-phase, 2.4/4.16 to 16/27.6 kV
- 13.2 Primary 3-phase line angle 16° to 45° 3-phase, 2.4/4.16 to 16/27.6 kV
- 13.3 Primary 3-phase line angle 16° to 60° 3-phase, 2.4/4.16 to 16/27.6 kV
- 13.4 Primary 3-phase line angle 61° to 90° 3-phase, 2.4/4.16 to 16/27.6 kV
- 14.1 Primary 3-phase, tangent, crossarm (LP insulator) 3-phase, 2.4/4.16 to 16/27.6 kV
- 14.2 Primary 3-phase, line angle 4° to 15° crossarm (LP insulator) 3-phase, 2.4/4.16 to 16/27.6 kV



For Your Safety

- 14.3 Primary 3-phase dead-end, crossarm (triangular) 3-phase, 2.4/4.16 to 16/27.6 kV
- 14.4 Primary 3-phase dead-end, crossarm (flat) 3-phase, 2.4/4.16 to 16/27.6 kV
- 15.1 Primary 3-phase underbuilt, tangent or line angle 0° to 15° 3-phase, 2.4/4.16 to 16/27.6 kV
- 15.2 Primary 3-phase, underbuilt tangent crossarm (LP insulator) 3-phase, 2.4/4.16 to 16/27.6 kV, maximum span 60 m (200 ft)
- 15.3 Primary 3-phase, underbuilt, line angle 4° to 15° crossarm (LP insulator) 3-phase, 2.4/4.16 to 16/27.6 kV, maximum span 60 m
- 16.1 Subtransmission 3-phase tangent, 3-phase, 44 kV
- 16.2 Subtransmission 3-phase dead-end, vertical 3-phase, 44 kV
- 17.1 Subtransmission 3-phase, line angle 4° to 15° 3-phase, 44 kV
- 17.2 Subtransmission 3-phase, line angle 16° to 45° 3-phase, 44 kV
- 17.3 Subtransmission 3-phase, line angle 16° to 60° 3-phase, 44 kV
- 17.4 Subtransmission 3-phase, line angle 61° to 90° 3-phase, 44 kV
- 18.1 Primary 3-phase tangent, crossarm 3-phase, 44 kV maximum span 90 m (300 ft)
- 18.2 Primary 3-phase, line angle 4° to 15°, crossarm 3-phase, 44 kV maximum span 90 m (300 ft)
- 18.3 Primary 3-phase dead-end, crossarm (triangular) 3-phase, 44 kV
- 18.4 Primary 3-phase dead-end, crossarm (flat) 3-phase, 44 kV
- 19 Steel plate anchor in soil
- 20 Log (slug) anchor in soil
- 21 Expansion anchor in soil
- 22 Earth screw anchor
- 23 Rock (solid hard) anchor
- 24 Shale and limestone anchor
- 25 Location of guy strain insulator joint use and non-joint use, armless or crossarm
- 26 Typical guy arrangements
- 27 Attachment of guys “pole fitting” to primary circuits
- 28 Service mast installation
- 29 Wood crossarm
- 30 Steel crossarm
- 31 Pin-type insulators for crossarm framing
- 32 Post-type insulators for armless framing
- 33 Suspension-type insulators
- 34 Grounding for overhead installations on wood poles
- 35 Details of secondary service rack or neutral spool
- 36 Secondary: Attaching service tap to an intermediate pole for support
- 37 Secondary: Attaching service tap to an intermediate pole for splitting into 2 or more services
- 38 Secondary: Connecting pre-assembled single-phase service below transformer
- 39 Secondary dead end



For Your Safety

- 40 Metering: 2.4 to 16 kV single-phase grounded primary
- 41 Metering: Central metering for secondary drop-leads 4/0 and smaller
- 42 Metering: Central metering for secondary drop-leads larger than 4/0
- 43 Metering for 3-phase, 120/208 V, 4-wire system
- 44 Grounding connection to steel pole, single-phase transformer
- 45 Grounding connection to steel pole, three-phase transformer



For Your Safety

Specification 1
**Minimum vertical clearances between wires
or conductors crossing in span**
[See Rules 75-302(3) and 75-304.]

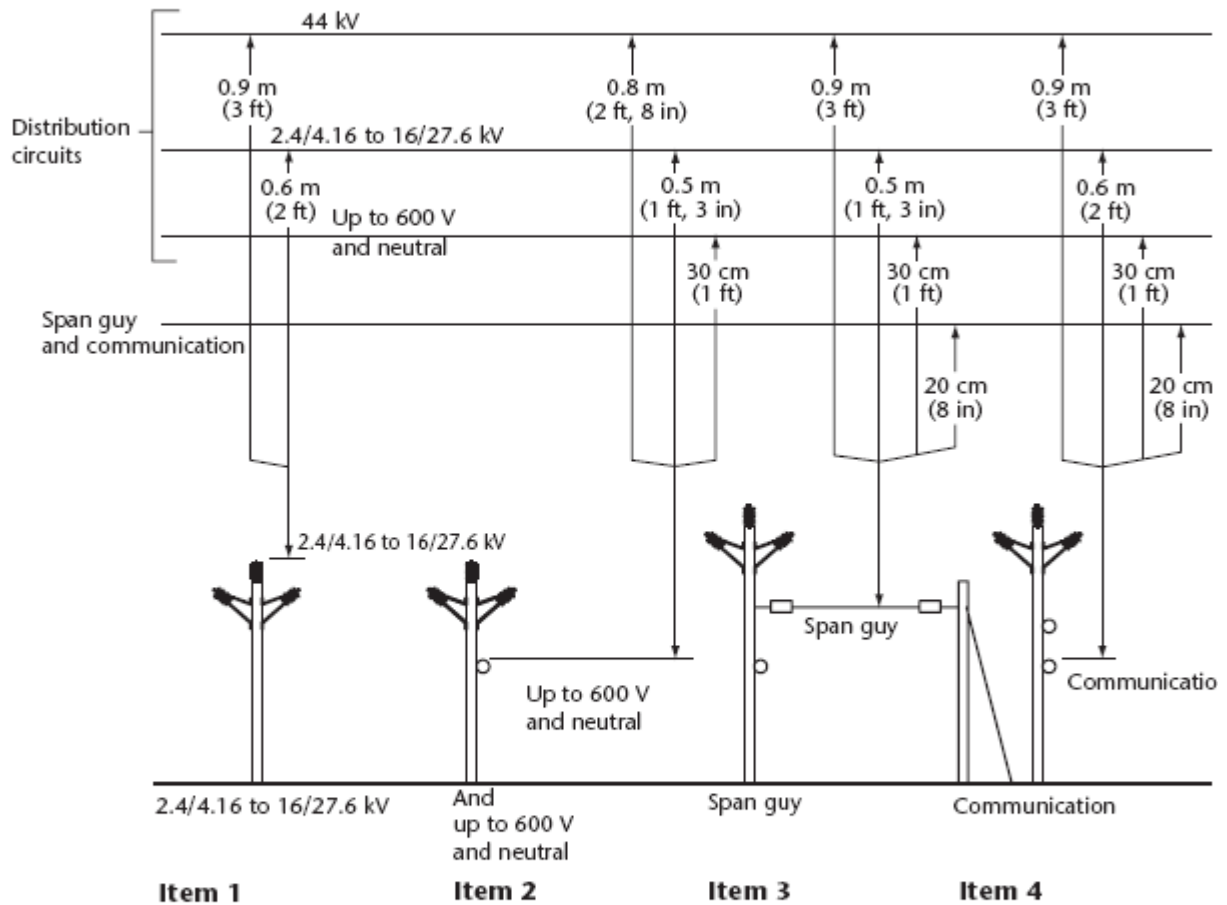

Note: All vertical clearances apply with the upper conductor at maximum sag and the lower conductor assumed to form a straight line between its point of support.



For Your Safety

Specification 2
Minimum vertical clearances in-span and separation at pole between supply and communication conductors
[See Rule 75-302(4).]

| System voltage of supply conductor | Minimum vertical clearance in-span | Minimum vertical separation at pole |
|---|------------------------------------|-------------------------------------|
| Up to 600 V — insulated or bare neutral | 0.2 cm (1/13 in) | 100 cm (3 ft, 2 in) |
| Up to 600 V — bare or covered | 10 cm (4 in) | 100 cm (3 ft, 2 in) |
| 2.4/4.16 to 16/27.6 kV | 40 cm (1 ft, 4 in) | 120 cm (4 ft) |
| 44 kV | 50 cm (1 ft, 8 in) | 150 cm (5 ft) |

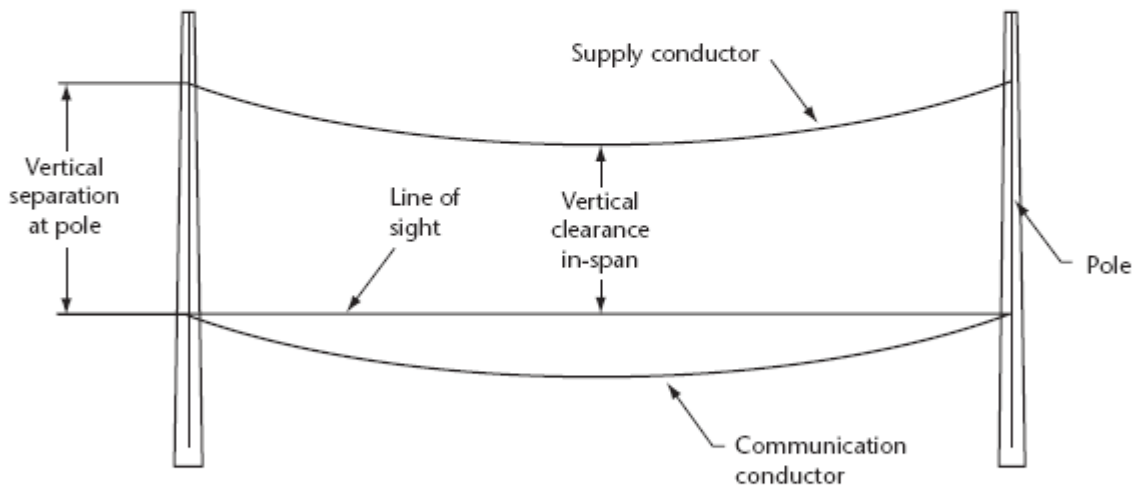

Minimum required vertical separation at pole = the greater of maximum supply conductor sag (from Tables 107 to 112) + minimum vertical clearance in-span (from Table)

or
Minimum vertical separation at pole (from Table)

Note: *The clearances in-span in the above table are under maximum sag conditions.*

For Your Safety

**Specification 3
Down-guy(s) and offset**
[See Rules 75-242(4) and 75-256(1).]

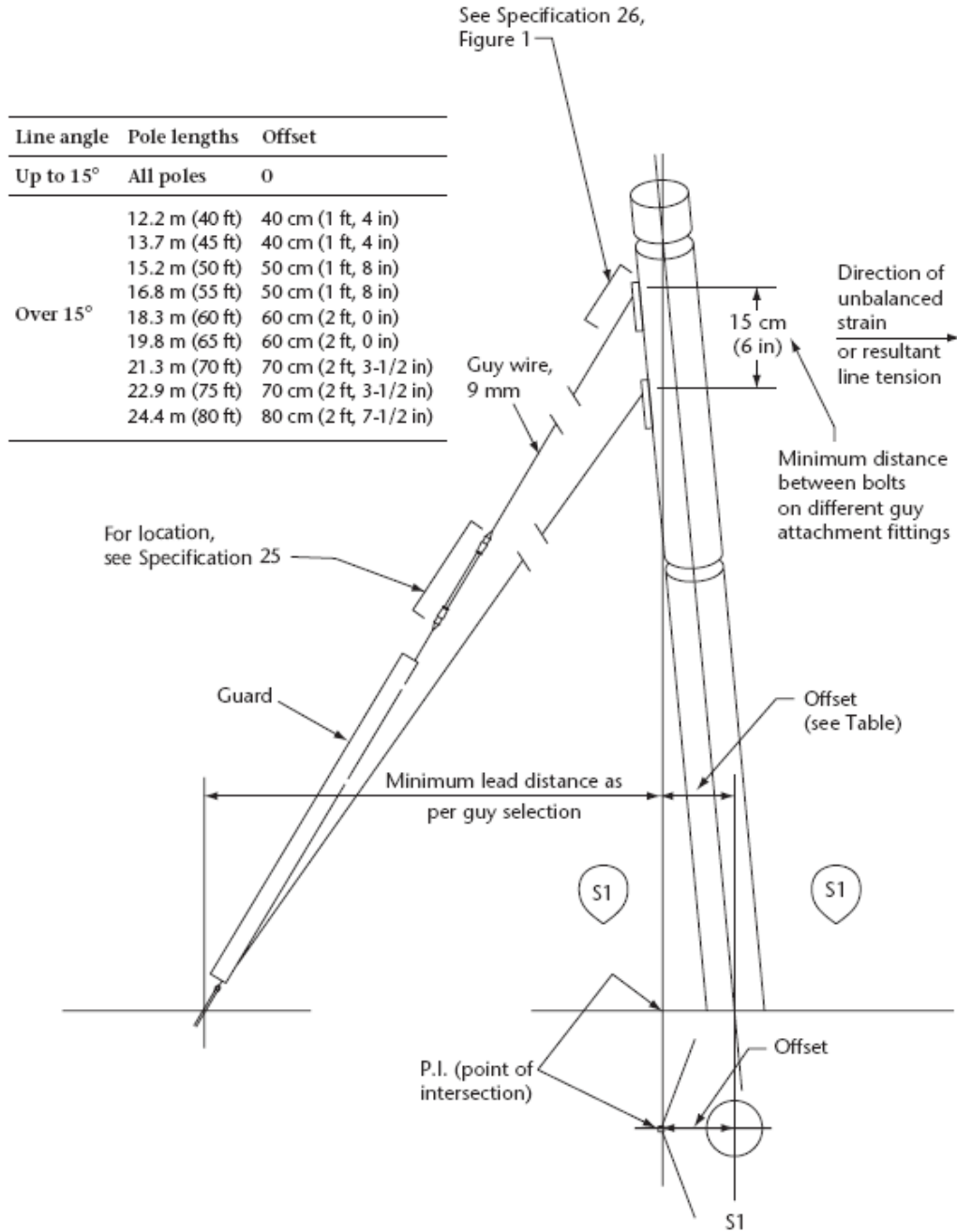



For Your Safety

Specification 4
Span and anchor guy
[See Rules 75-242(4) and 75-254(1).]

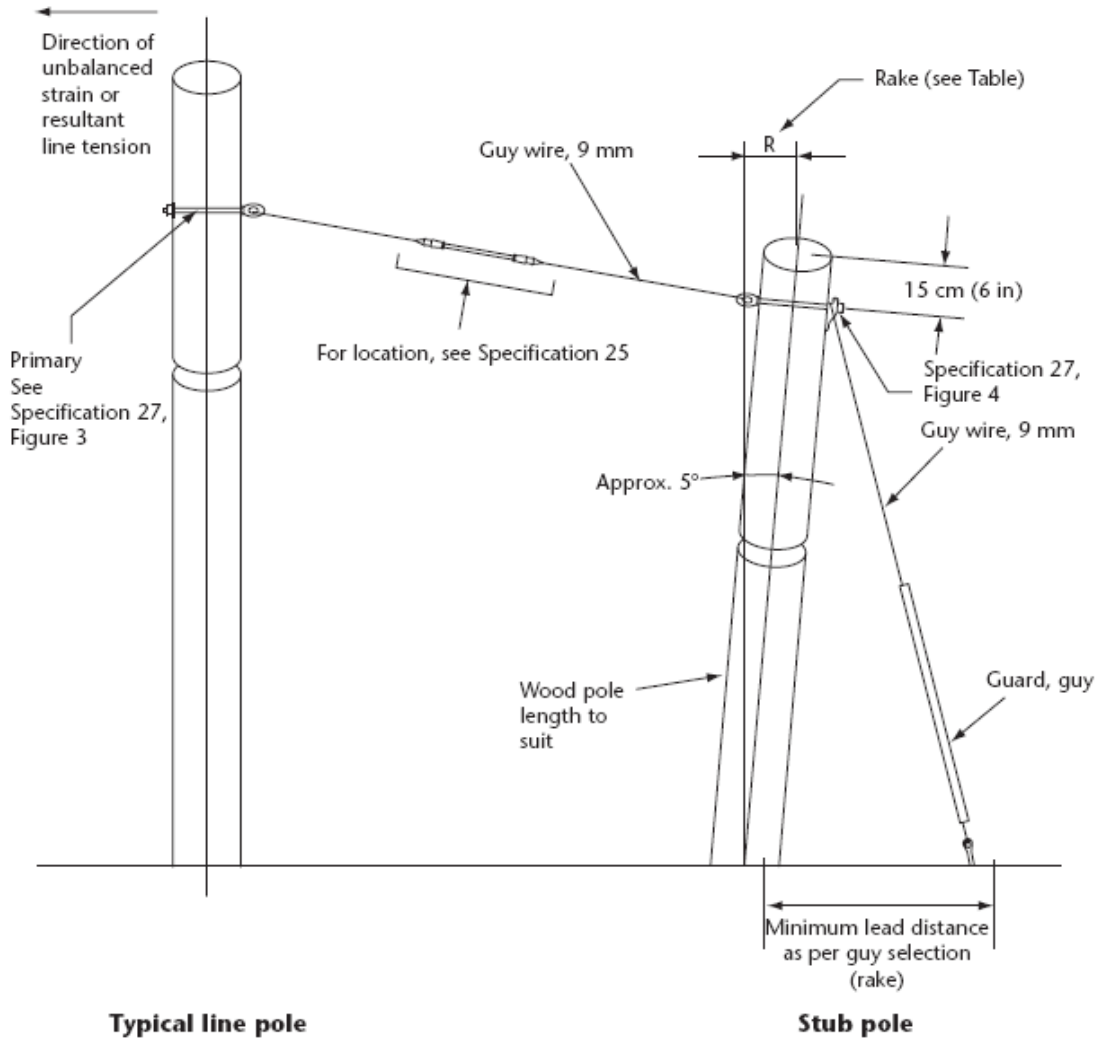

| Stub lengths | Rake (approx.) |
|----------------|------------------------|
| 9.1 m (30 ft) | 60 cm (2 ft, 0 in) |
| 10.7 m (35 ft) | 70 cm (2 ft, 3-1/2 in) |
| 12.2 m (40 ft) | 80 cm (2 ft, 7-1/2 in) |

Note: If stub pole carries power circuit, refer to Specification 3, excluding pole offset requirements.



For Your Safety

**Specification 5
Pole mounts for rock**

[See Rule 75-242(5).]

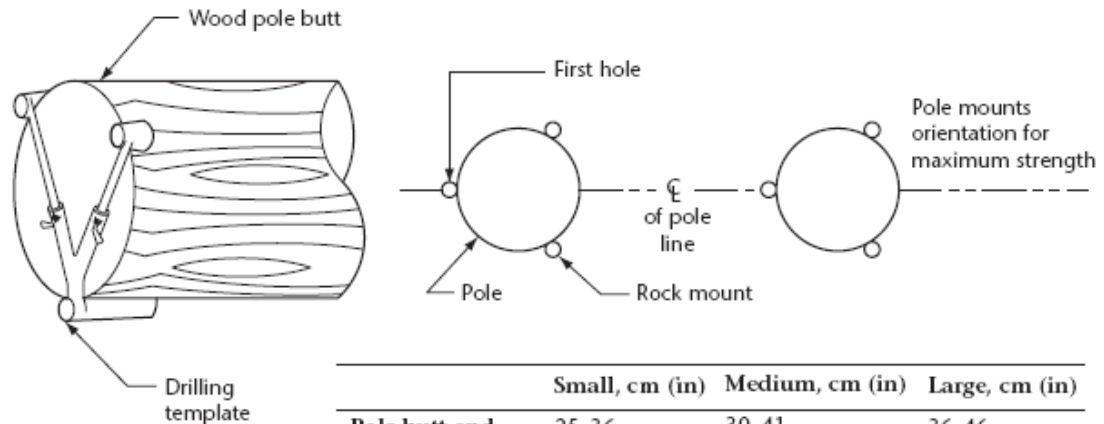

| | Small, cm (in) | Medium, cm (in) | Large, cm (in) |
|-------------------------------------|------------------|------------------|------------------|
| Pole butt end diameter range | 25-36 (10-14) | 30-41 (12-16) | 36-46 (14-18) |
| Rock drill diameter | 64 mm (2-1/2 in) | | |

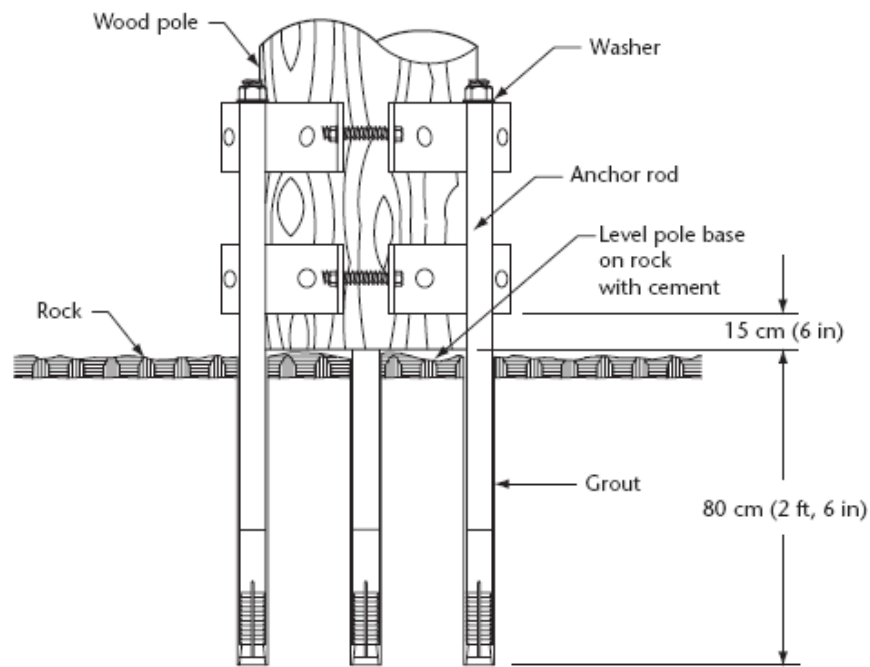

Note: Nut of anchor rod shall be tightened firmly to expand expansion shell.



For Your Safety

Specification 6
Swamp cribbing with steel culvert section for wood poles
[See Rule 75-242(6).]

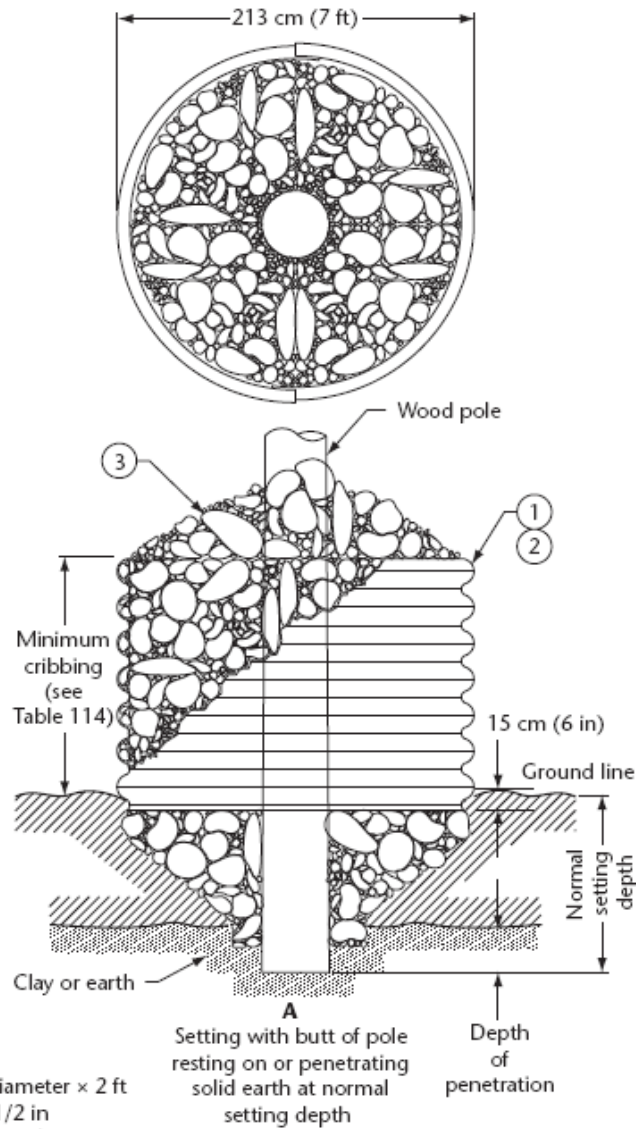



For Your Safety

Specification 7
Swamp cribbing with steel culvert section for wood poles
[See Rule 75-242(6).]

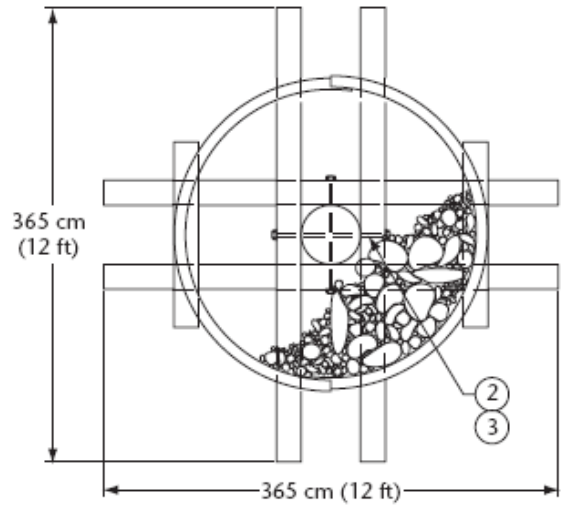

| Bolts required | |
|---------------------|------------|
| Cribbing height, cm | Part No. 5 |
| 60 | 12 |
| 120 | 30 |
| 180 | 48 |

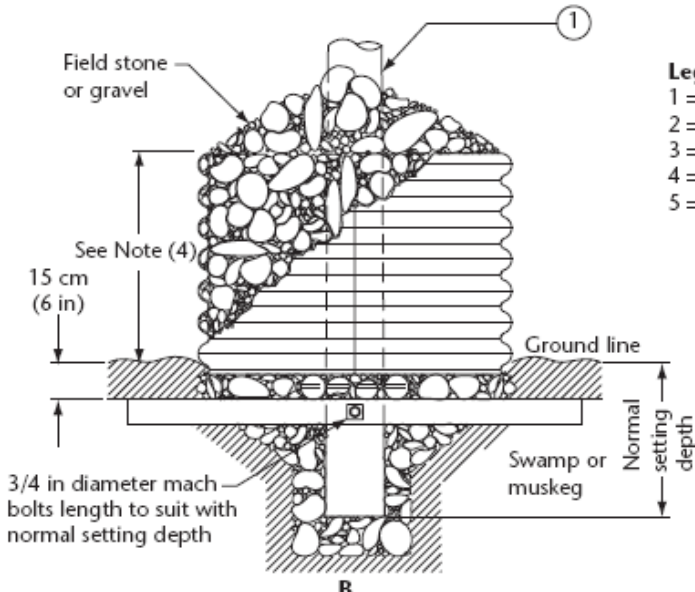

- Legend:**
- 1 = Wood pole
 - 2 = Bolt, 3/4 in
 - 3 = Washer, 3/4 in x 2 in x 2 in
 - 4 = Cribbing, 7 ft diameter x 2 ft
 - 5 = Bolt assembly, 1/2 in

B
Setting with butt of pole not reaching solid earth at normal setting depth

- Notes:**
- (1) Material of steel culvert to be No. 14 gauge corrugated steel, hot-dipped galvanized.
 - (2) Timbers to be cedar or treated hardwood (round or square) not less than 10 to 15 cm (4 to 6 in) square.
 - (3) Height of crib will vary with pole.
 - (4) Height and depth of penetration of butt into solid earth. Minimum height of crib is 60 cm (2 ft). See Table 114.
 - (5) Where ground condition is very soft, spread 25 cm (10 in) of brush under timbers.



For Your Safety

**Specification 8
Depth of pole setting reduction using steel culvert supports**

[See Rule 75-242(6).]

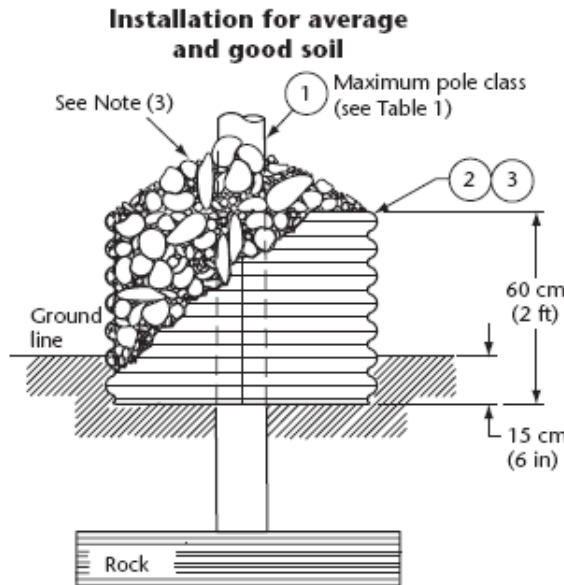

Figure 1
Overburden up to 18 in short of normal soil setting depth (shown)

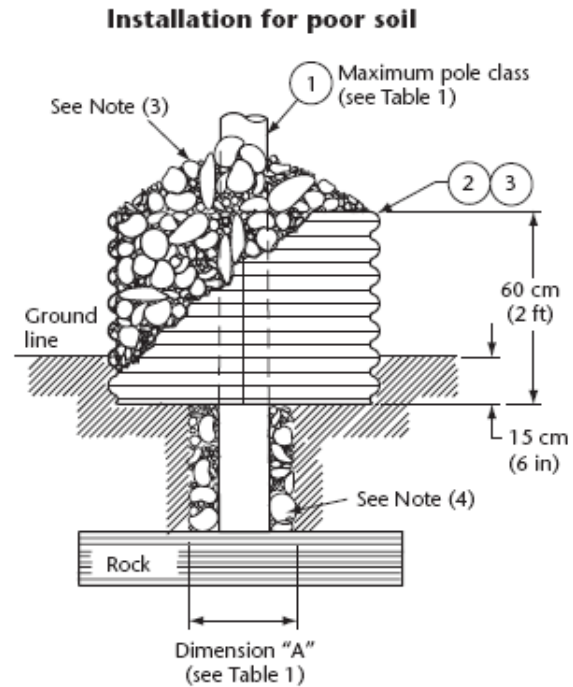

Figure 2
Overburden up to 18 in short of normal soil setting depth (shown)

Legend:

- 1 = Pole
- 2 = Cribbing, 7 ft diameter × 2 ft high
- 3 = Bolt, 1/2 in × 1-1/4 in long

Notes:

- (1) The use of culvert for partial substitution of normal setting depth in soil shall be limited to two (2) adjacent pole locations.
- (2) Poles shall bear on bedrock.
- (3) Culvert fill material shall be either (a) field stones; (b) well-tamped gravel; or (c) inorganic soil, mechanically compacted in 6 in layers.
- (4) Pole backfill material for installation for poor soil shall be either field stones or well-tamped gravel.
- (5) The foundation moment capacity was used to determine the maximum pole class limits. The calculated groundline moment produced by maximum pole class shall not be exceeded.

Installation

Required steel culverts

| Overburden/short of normal soil setting | Average and good soil (see Figure 1) | Poor soil (see Figure 2) |
|--|--------------------------------------|--------------------------|
| Up to 46 cm (18 in) | 60 cm (2 ft, 0 in) | 60 cm (2 ft, 0 in) |
| From 46 cm (18 in) to 76 cm (2 ft, 6 in) | 122 cm (4 ft, 0 in) | 122 cm (4 ft, 0 in) |

Table 1

Maximum pole class [see Note (5)]

| Pole height, ft | Maximum pole class | | |
|-----------------|------------------------|---------------------------|-----------|
| | Poor soil Dim A = 2 ft | Average soil Dim A = 3 ft | Good soil |
| Up to 40 | 5 | 4 | 2 |
| 45 to 55 | 4 | 3 | 1 |
| 60 & 65 | 3 | 2 | 1 |



For Your Safety

Specification 9.1
Primary 1-phase tangent (pin insulator) 1-phase,
2.4 to 8.0 kV, maximum span 90 m (300 ft)
[See Rule 75-244(3).]

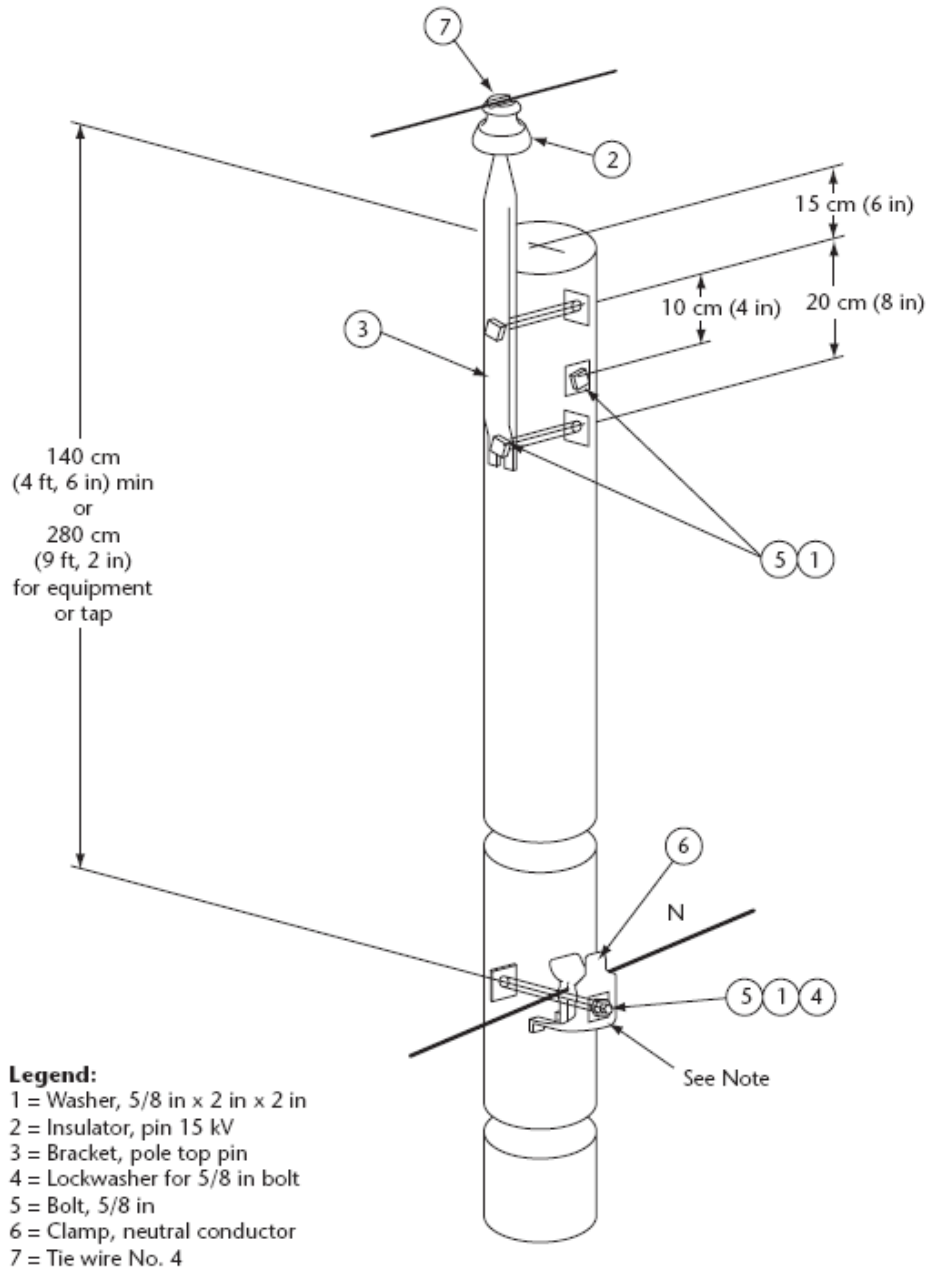

Note: See Specification 35, Figure 2.



For Your Safety

Specification 10.1
Primary 1-phase tangent (LP insulator) 1-phase,
2.4 to 16 kV, maximum span 90 m (300 ft)
[See Rule 75-244(3).]

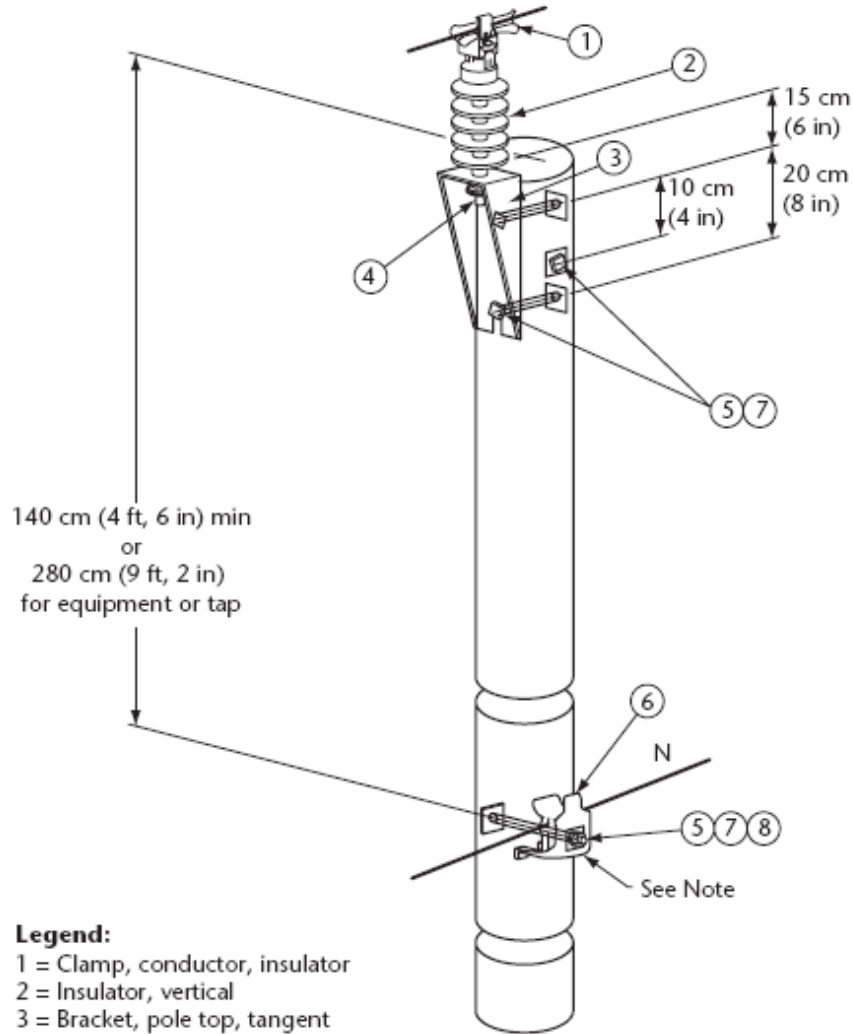

- Legend:**
- 1 = Clamp, conductor, insulator
 - 2 = Insulator, vertical
 - 3 = Bracket, pole top, tangent
 - 4 = Stud, insulator
 - 5 = Bolt, 5/8 in
 - 6 = Clamp, neutral conductor
 - 7 = Washer, 5/8 in × 2 in × 2 in
 - 8 = Lockwasher for 5/8 in bolt

Note: See Specification 35, Figure 2.



For Your Safety

Specification 10.2
Primary 1-phase line angle 4° to 15° (LP insulator) 1-phase,
2.4 to 16 kV, maximum span 90 m (300 ft)
[See Rule 75-244(3).]

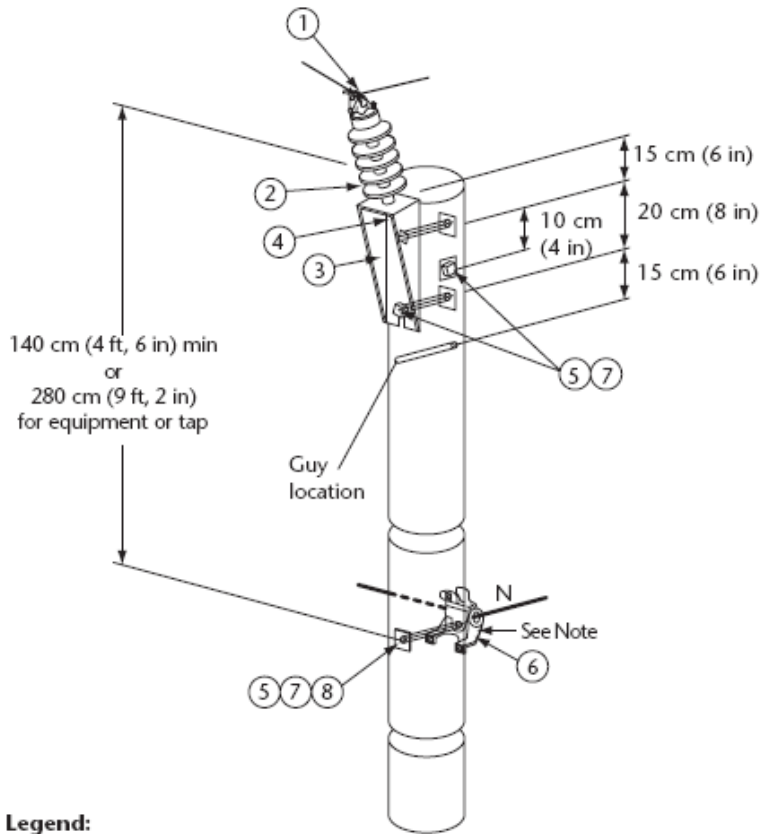

Legend:

- 1 = Clamp, conductor, insulator
- 2 = Insulator, vertical
- 3 = Bracket, pole top, angle
- 4 = Stud, insulator
- 5 = Bolt, 5/8 in
- 6 = Clamp, neutral conductor
- 7 = Washer, 5/8 in × 2 in × 2 in
- 8 = Lockwasher for 5/8 in bolt

Note: See Specification 35, Figure 1.

For Your Safety

Specification 10.3
Primary 1-phase line angle 16° to 60° 1-phase,
2.4 to 16 kV, maximum span 90 m (300 ft)
 [See Rule 75-244(3).]

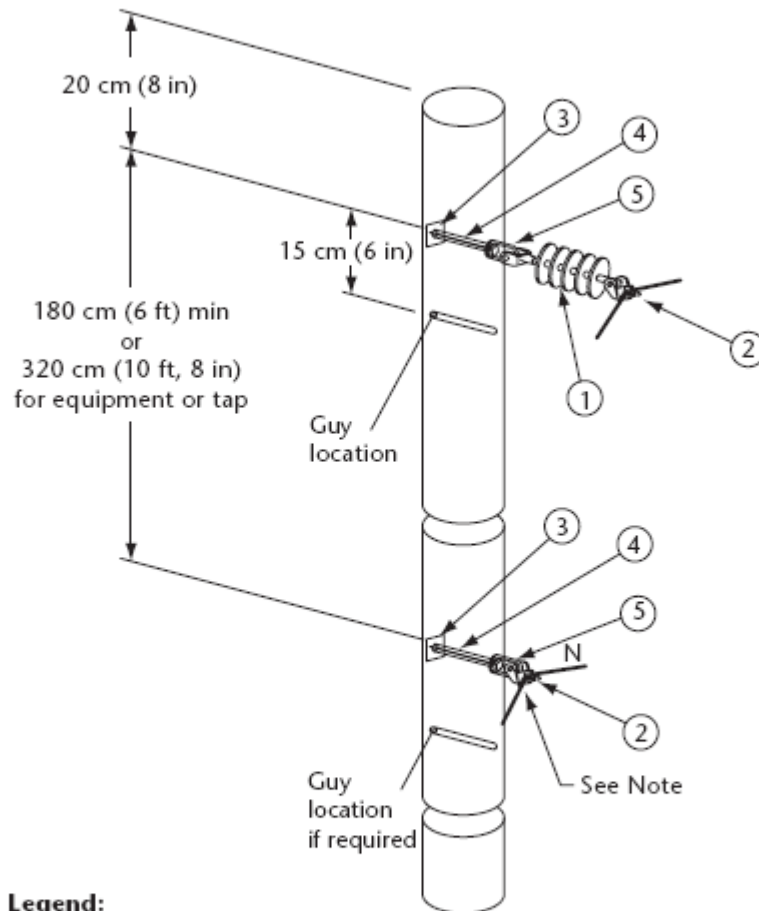

- Legend:**
- 1 = Insulator, dead-end
 - 2 = Clamp, conductor, angle
 - 3 = Washer, 5/8 in × 2 in × 2 in
 - 4 = Bolt, 5/8 in
 - 5 = Bolt eye for 5/8 in bolt

Note: See Specification 35, Figure 1.



For Your Safety

Specification 10.4
Primary 1-phase line angle 61° to 90° 1-phase,
2.4 to 16 kV, maximum span 90 m (300 ft)
[See Rule 75-244(3).]

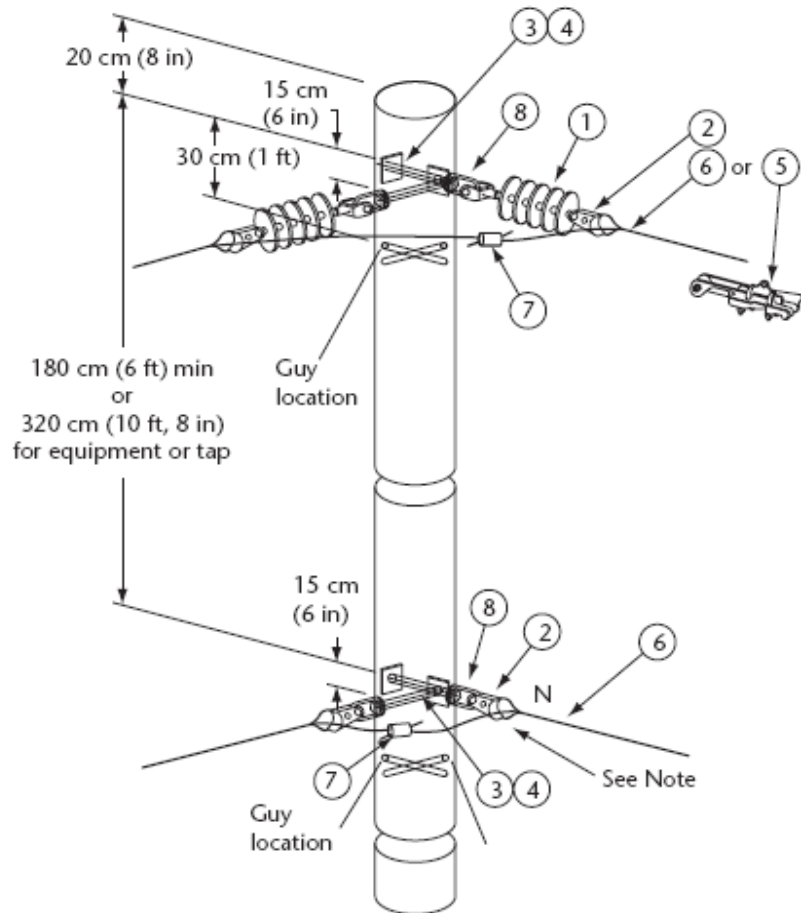

Legend:

- 1 = Insulator, dead-end
- 2 = Clevis bail, dead-end
- 3 = Washer, 5/8 in x 2 in x 2 in
- 4 = Bolt, 5/8 in
- 5 = Clamp, conductor, bolted, dead-end
- 6 = Grip, conductor, preformed, dead-end
- 7 = Connector, wedge type
- 8 = Bolt eye for 5/8 in bolt

Note: See Specification 35, Figure 1.



For Your Safety

Specification 10.5
Primary 1-phase dead-end 1-phase, 2.4 to 16 kV,
maximum span 90 m (300 ft)
[See Rule 75-244(3).]

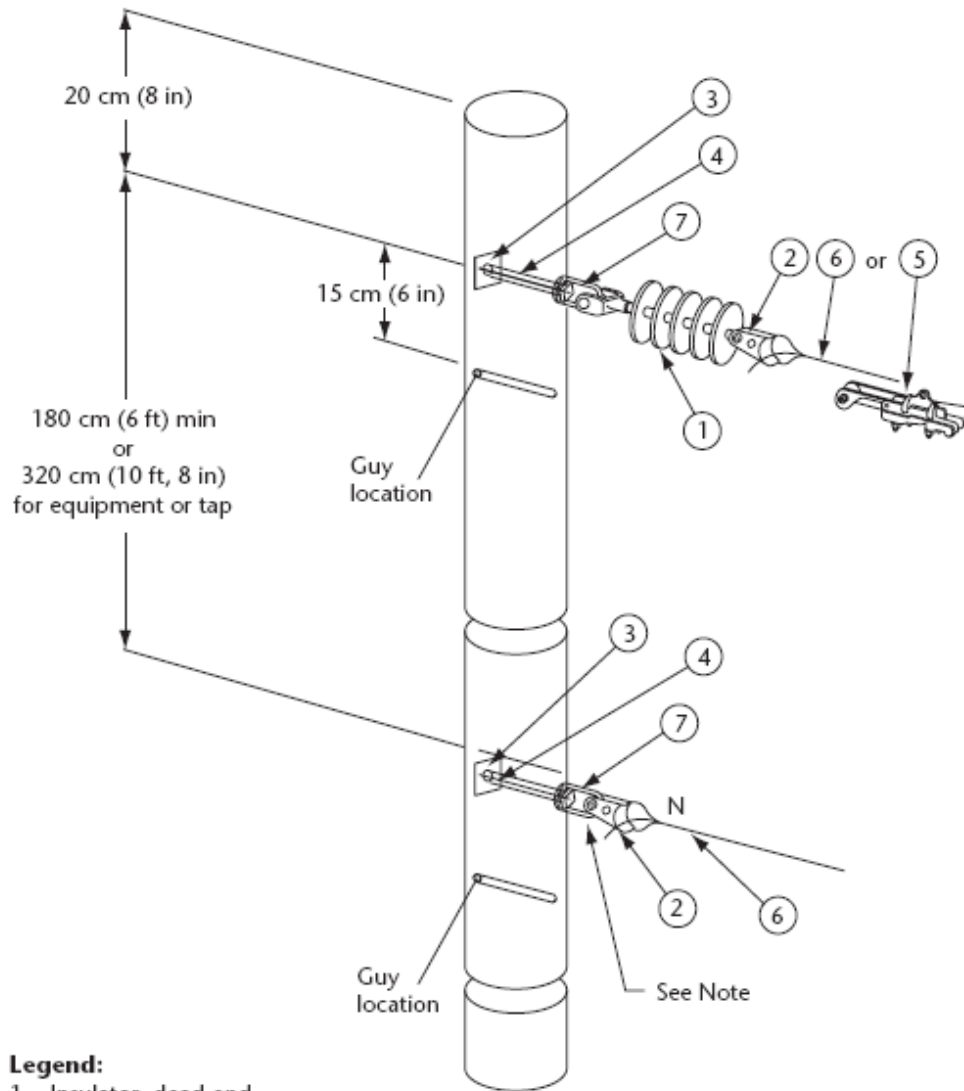

- Legend:**
- 1 = Insulator, dead-end
 - 2 = Clevis bail, dead-end
 - 3 = Washer, 5/8 in × 2 in × 2 in
 - 4 = Bolt, 5/8 in
 - 5 = Clamp, conductor, bolted, dead-end
 - 6 = Grip, conductor, preformed, dead-end
 - 7 = Bolt eye for 5/8 in bolt

Note: See Specification 35, Figure 1.



For Your Safety

Specification 11.1

Primary 3-phase, underbuilt, line angle 4° to 15° crossarm (pin insulator)

3-phase, 2.4/4.16 to 8.0/13.8 kV, maximum span 60 m (200 ft)

[See Rule 75-244(3).]

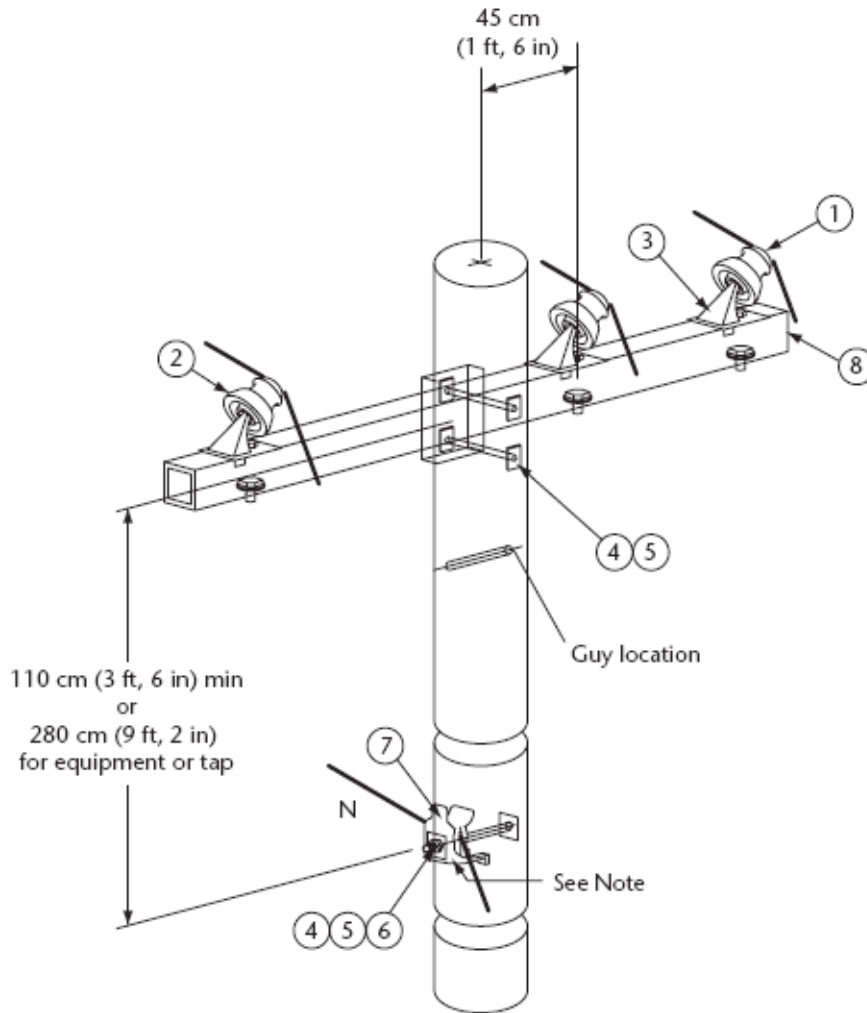

Legend:

- 1 = Tie wire No. 4
- 2 = Insulator, pin 15 kV
- 3 = Angle insulator pin
- 4 = Bolt, 5/8 in
- 5 = Washer, 5/8 in x 2 in x 2 in
- 6 = Lockwasher for 5/8 in bolt
- 7 = Clamp, neutral conductor
- 8 = Crossarm, 9 ft, 6 in steel

Note: See Specification 35, Figure 1.



For Your Safety

Specification 11.2
Primary 3-phase, line angle 4° to 15° crossarm
(pin insulator) 3-phase, 2.4/4.16 to 8.0/13.8 kV
[See Rule 75-244(3).]

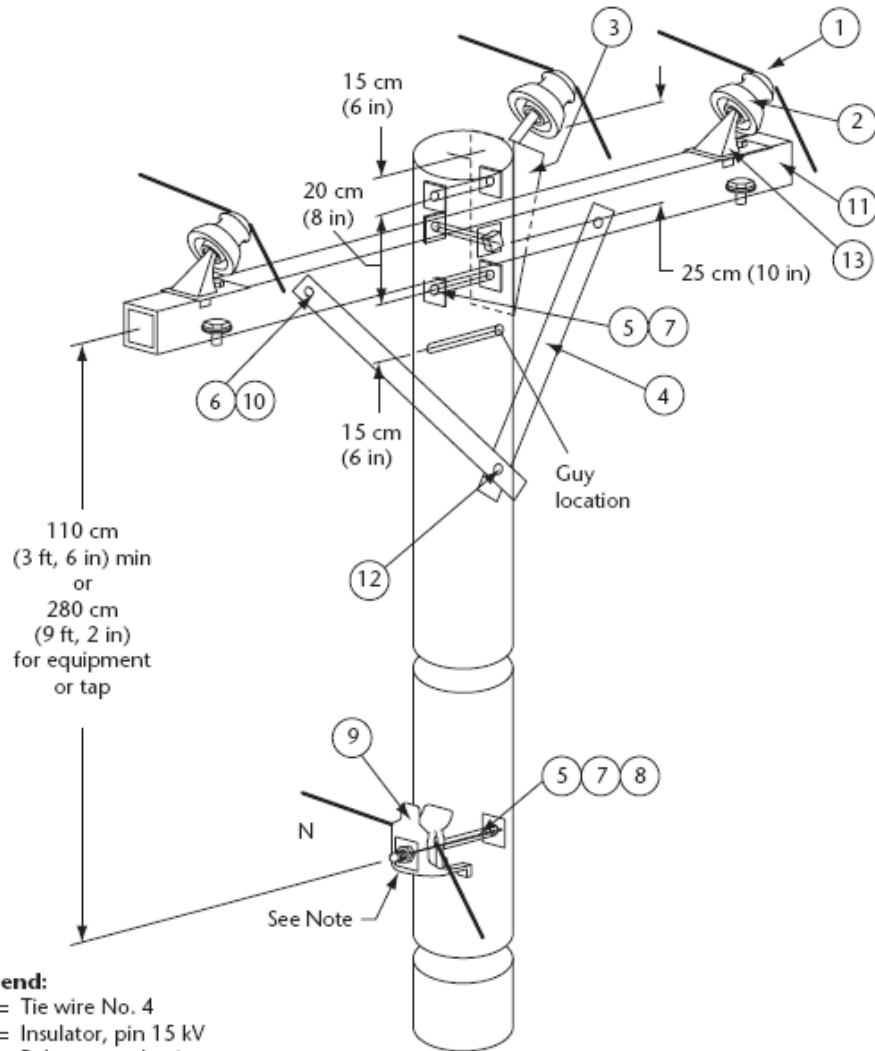

- Legend:**
- 1 = Tie wire No. 4
 - 2 = Insulator, pin 15 kV
 - 3 = Pole top angle pin
 - 4 = Brace
 - 5 = Bolt, 5/8 in
 - 6 = Bolt, 3/8 in
 - 7 = Washer, 5/8 in × 2 in × 2 in
 - 8 = Lockwasher for 5/8 in bolt
 - 9 = Clamp, neutral conductor
 - 10 = Washer, rd. 3/8 in
 - 11 = Crossarm, wood (see span)
 - 12 = Screw, lag 1/2 in × 4-1/2 in
 - 13 = Angle insulator pin

Note: See Specification 35, Figure 1.

| For max. span | Crossarm |
|---------------|---------------------------|
| 75 m (250 ft) | 250 cm (8 ft, 4 in) wood |
| 90 m (300 ft) | 290 cm (9 ft, 10 in) wood |



For Your Safety

Specification 11.3

**Primary 3-phase, underbuilt tangent crossarm (pin insulator)
3-phase, 2.4/4.16 to 8.0/13.8 kV, maximum span 60 m (200 ft)**

[See Rule 75-244(3).]

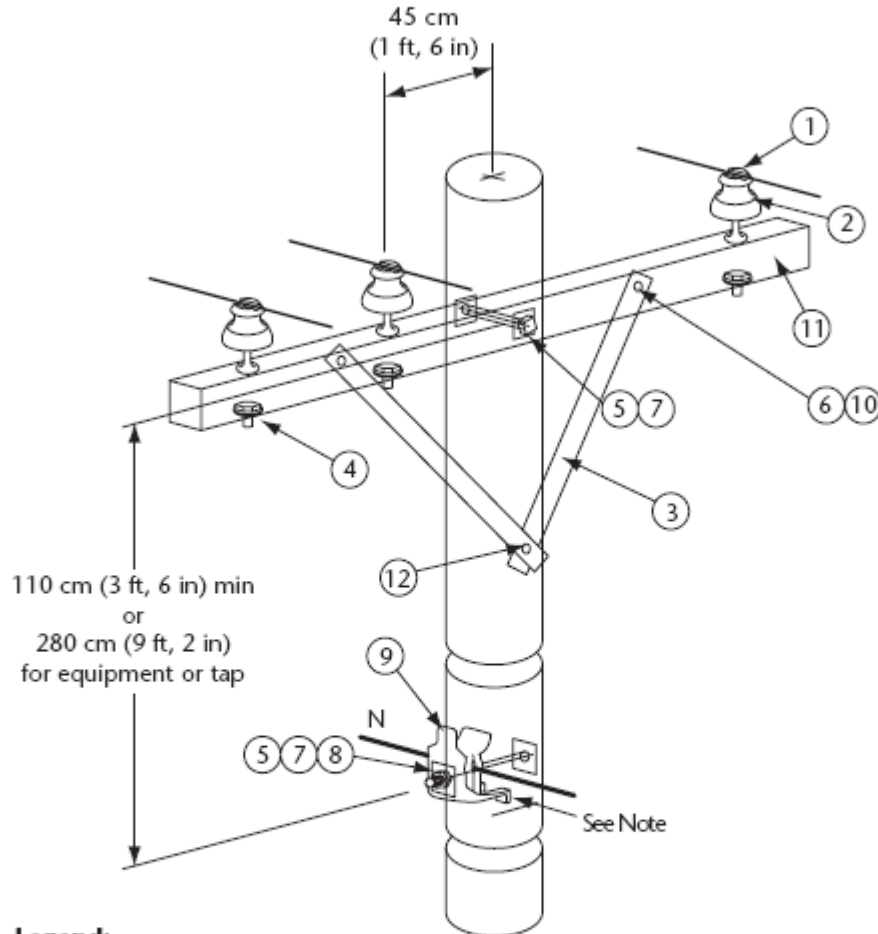

Legend:

- 1 = Tie wire No. 4
- 2 = Insulator, pin 15 kV
- 3 = Brace
- 4 = Steel insulator pin
- 5 = Bolt, 5/8 in
- 6 = Bolt, 3/8 in
- 7 = Washer, 5/8 in x 2 in x 2 in
- 8 = Lockwasher for 5/8 in bolt
- 9 = Clamp, neutral conductor
- 10 = Washer, rd. 3/8 in
- 11 = Crossarm, wood, 9 ft, 10 in (300 cm)
- 12 = Screw, lag 1/2 in x 4-1/2 in

Note: See Specification 35, Figure 2.



For Your Safety

Specification 11.4
Primary 3-phase, tangent, crossarm (pin insulator)
3-phase, 2.4/4.16 to 8.0/13.8 kV
[See Rule 75-244(3).]

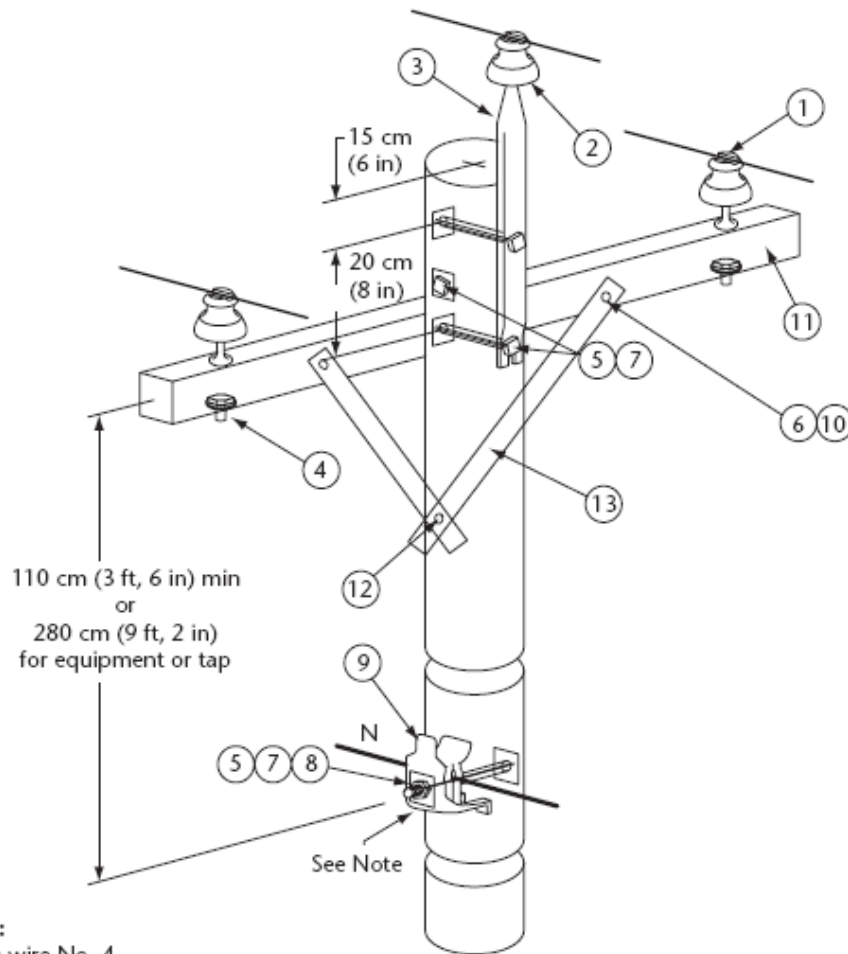

Legend:

- 1 = Tie wire No. 4
- 2 = Insulator, pin 15 kV
- 3 = Pole top pin
- 4 = Steel insulator pin
- 5 = Bolt, 5/8 in
- 6 = Bolt, 3/8 in
- 7 = Washer, 5/8 in x 2 in x 2 in
- 8 = Lockwasher for 5/8 in bolt
- 9 = Clamp, neutral conductor
- 10 = Washer, rd. 3/8 in
- 11 = Crossarm, wood (see span)
- 12 = Screw, lag 1/2 in x 4-1/2 in
- 13 = Brace

Note: See Specification 35, Figure 2.

| For maximum span | Crossarm | Conductors |
|------------------|--------------------------|-----------------------|
| 75 m (250 ft) | 250 cm (8 ft, 4 in) wood | No. 2-556 |
| 90 m (300 ft) | 290 cm (9 ft, 6 in) wood | No. 2-3/0; 336-556 |



For Your Safety

Specification 12.1
Primary 3-phase, tangent 3-phase, 2.4/4.16 to 16/27.6 kV
[See Rule 75-244(3).]

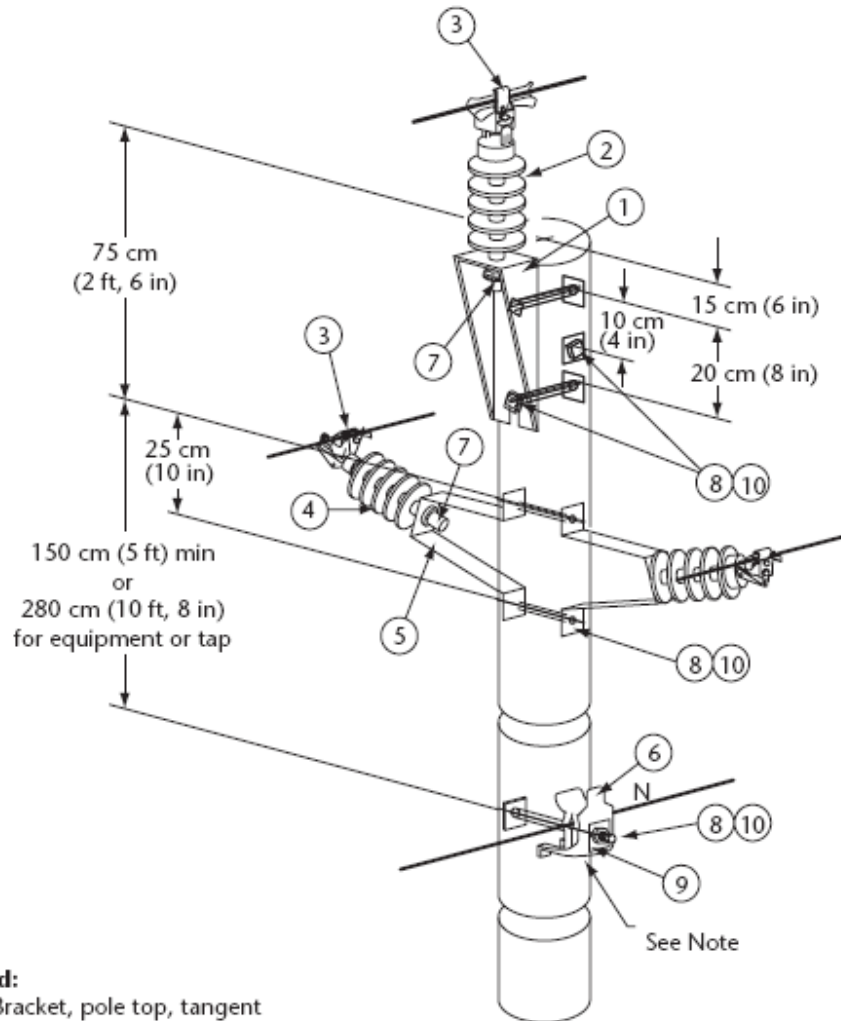

Legend:

- 1 = Bracket, pole top, tangent
- 2 = Insulator, vertical
- 3 = Clamp, conductor, insulator
- 4 = Insulator, horizontal
- 5 = Bracket, stand-off (see span)
- 6 = Clamp, neutral conductor
- 7 = Stud, insulator
- 8 = Bolt, 5/8 in
- 9 = Lockwasher for 5/8 in bolt
- 10 = Washer, 5/8 in × 2 in × 2 in

| For maximum span | Stand-off bracket |
|------------------|--------------------|
| 75 m (250 ft) | 23 cm (9 in) wood |
| 90 m (300 ft) | 45 cm (18 in) wood |

Note: See Specification 35, Figure 2.



For Your Safety

**Specification 12.2
Primary 3-phase dead-end vertical 3-phase,
2.4/4.16 to 16/27.6 kV**
[See Rule 75-244(3).]

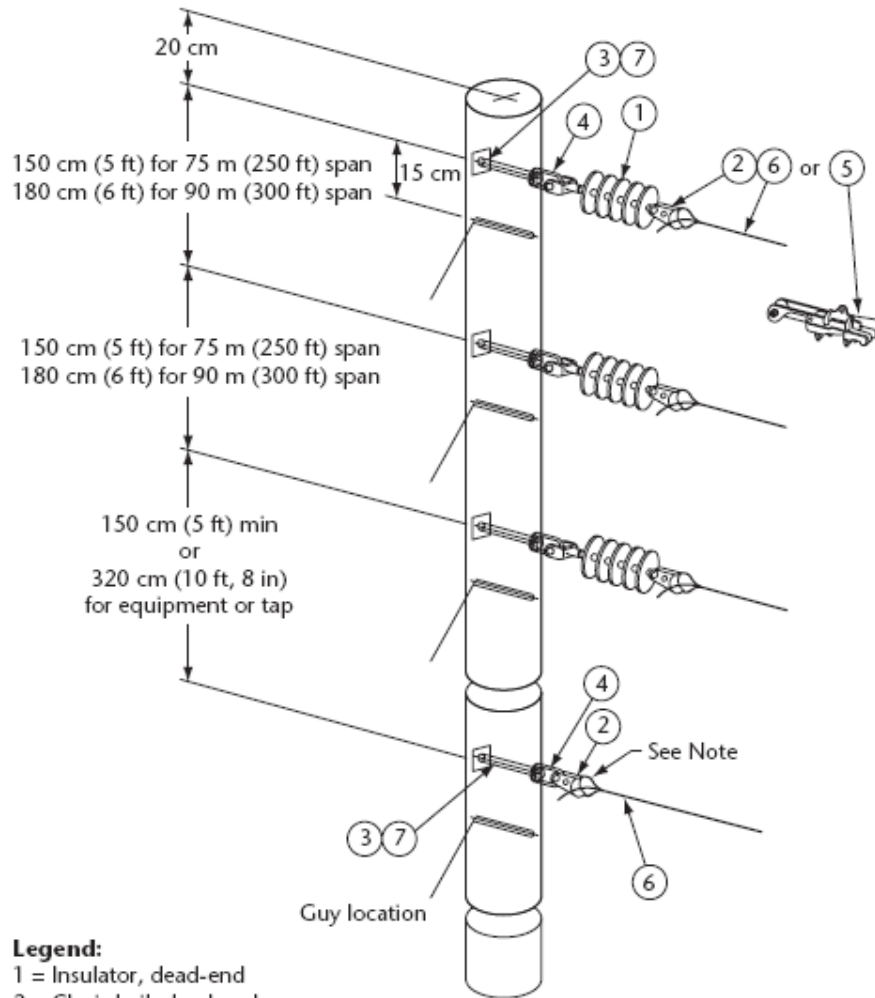

- Legend:**
- 1 = Insulator, dead-end
 - 2 = Clevis bail, dead-end
 - 3 = Washer for 5/8 in bolt
 - 4 = Bolt eye for 5/8 in bolt
 - 5 = Clamp, conductor, bolted, dead-end
 - 6 = Grip, conductor, preformed, dead-end
 - 7 = Bolt, 5/8 in

Note: See Specification 35, Figure 1.

For Your Safety

Specification 12.3
Primary 3-phase tree framing 3-phase,
2.4/4.16 to 16/27.6 kV
[See Rule 75-244(3).]

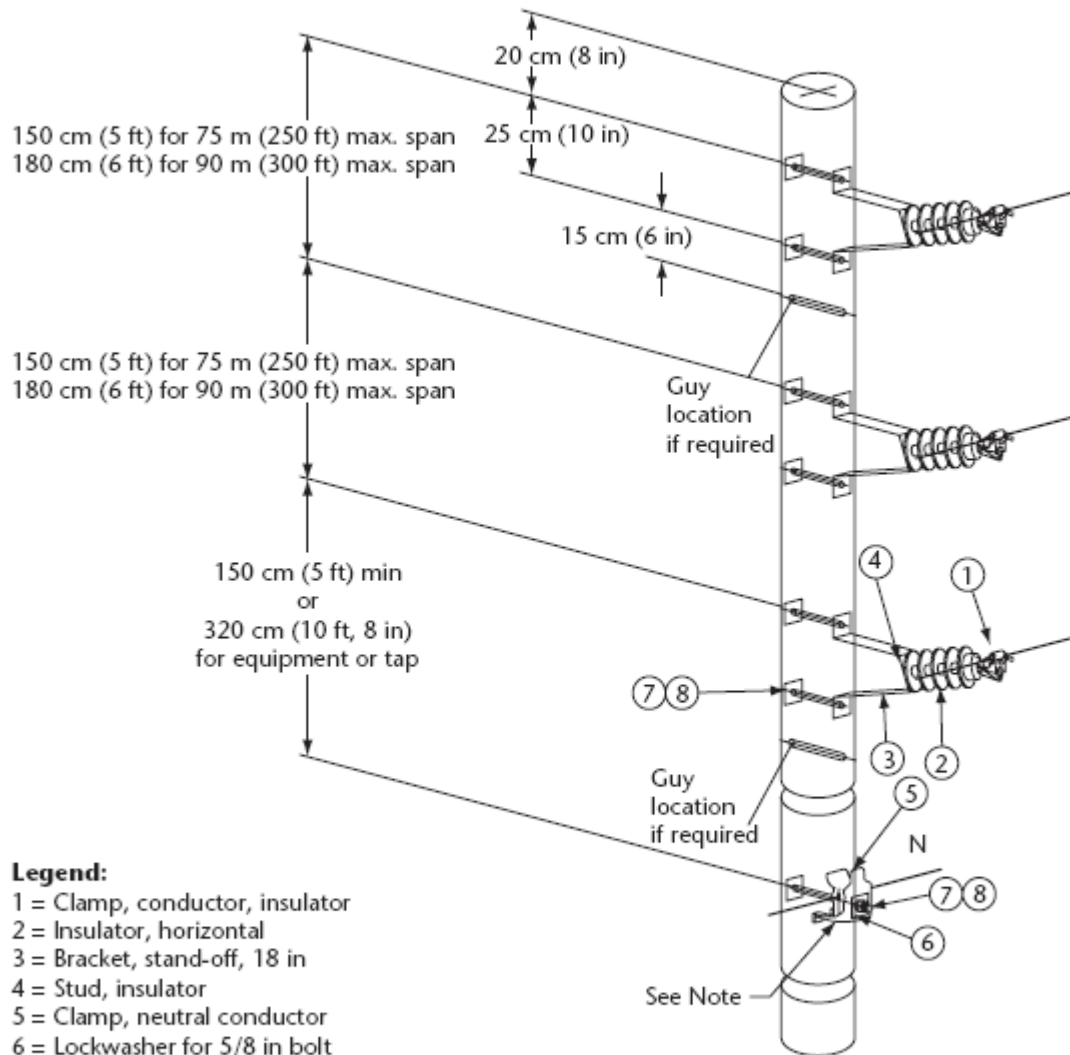

- Legend:**
- 1 = Clamp, conductor, insulator
 - 2 = Insulator, horizontal
 - 3 = Bracket, stand-off, 18 in
 - 4 = Stud, insulator
 - 5 = Clamp, neutral conductor
 - 6 = Lockwasher for 5/8 in bolt
 - 7 = Bolt, 5/8 in
 - 8 = Washer, 5/8 in x 2 in x 2 in

Note: See Specification 35, Figure 2.



For Your Safety

Specification 13.1
Primary 3-phase line angle 4° to 15° 3-phase,
2.4/4.16 to 16/27.6 kV
 [See Rule 75-244(3).]

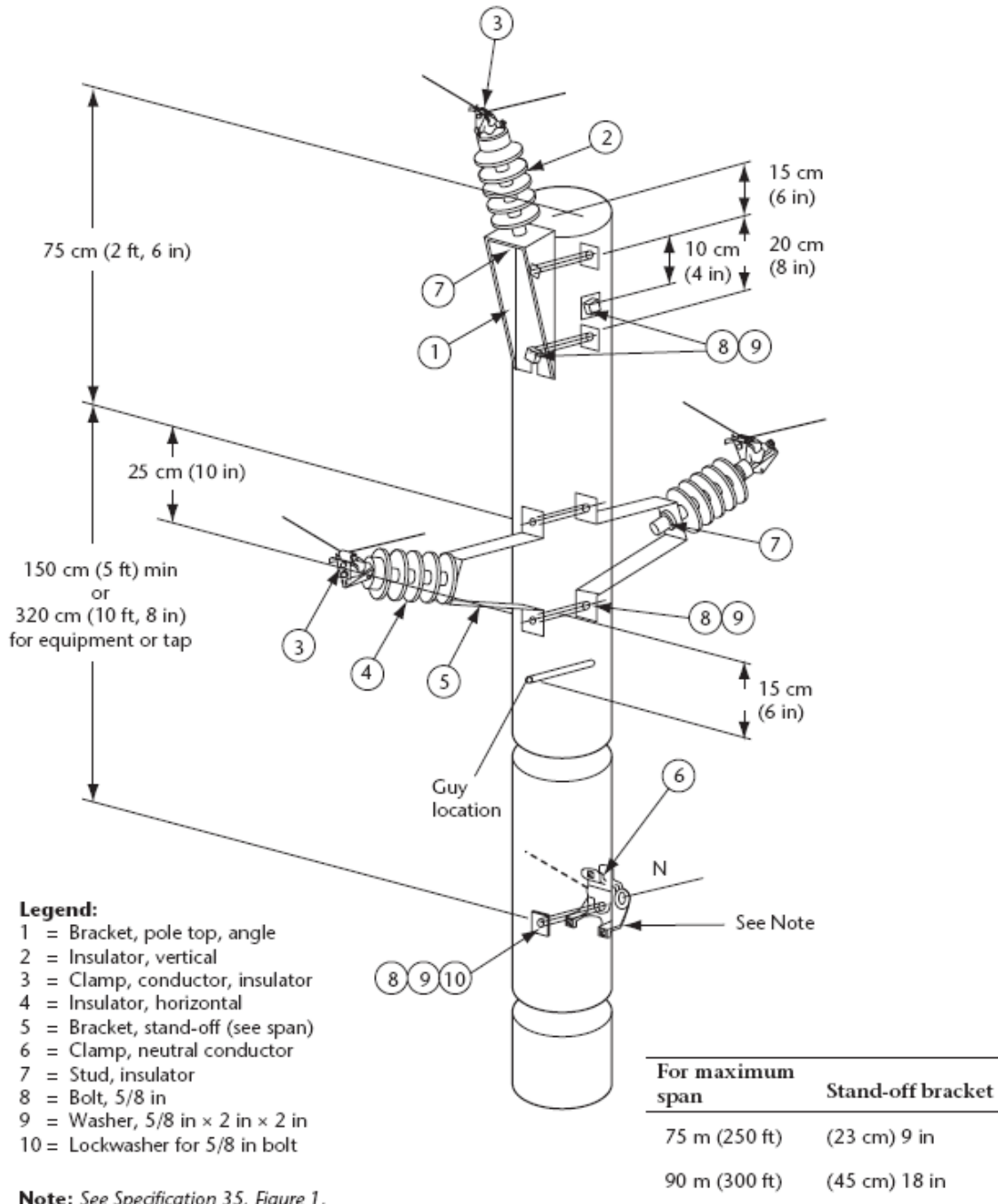

Note: See Specification 35, Figure 1.



For Your Safety

Specification 13.2
Primary 3-phase line angle 16° to 45° 3-phase,
2.4/4.16 to 16/27.6 kV
[See Rule 75-244(3).]

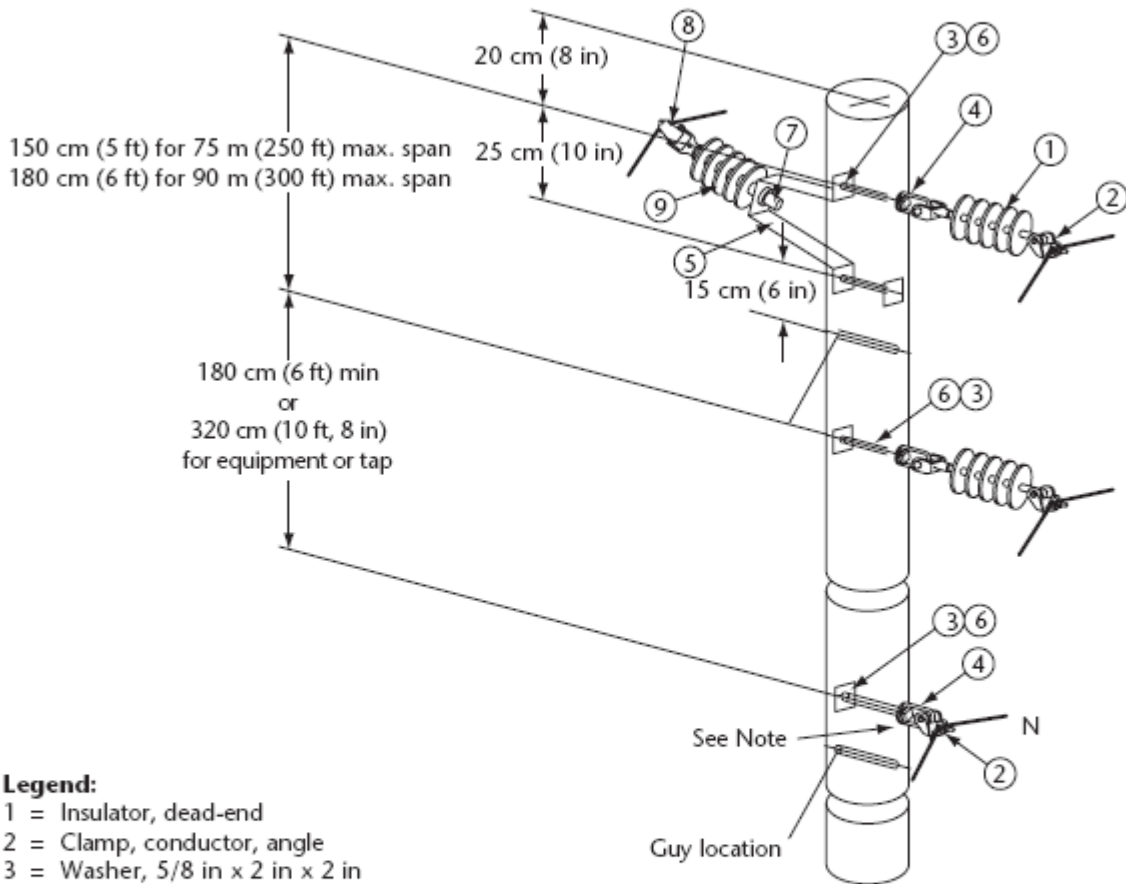

Legend:

- 1 = Insulator, dead-end
- 2 = Clamp, conductor, angle
- 3 = Washer, 5/8 in x 2 in x 2 in
- 4 = Bolt eye for 5/8 in bolt
- 5 = Bracket, stand-off
- 6 = Bolt, 5/8 in
- 7 = Stud, insulator
- 8 = Clamp, conductor, insulator
- 9 = Insulator, vertical

Note: See Specification 35, Figure 1.

| For maximum span | Stand-off bracket |
|------------------|-------------------|
| 75 m (250 ft) | (23 cm) 9 in |
| 90 m (300 ft) | (45 cm) 18 in |

For Your Safety

Specification 13.3
Primary 3-phase line angle 16° to 60° 3-phase,
2.4/4.16 to 16/27.6 kV
 [See Rule 75-244(3).]

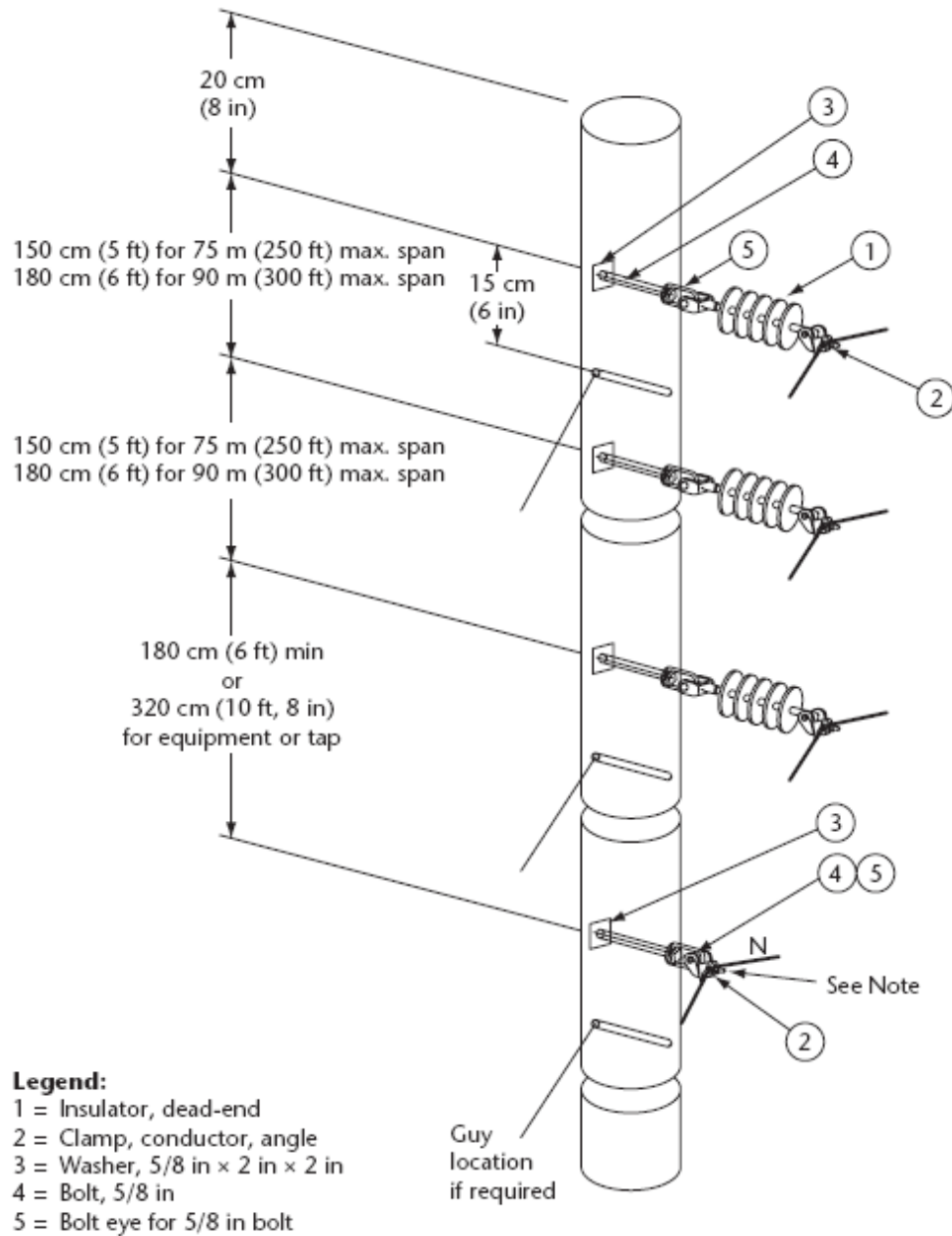

Note: See Specification 35, Figure 1.



For Your Safety

Specification 13.4
Primary 3-phase line angle 61° to 90° 3-phase,
2.4/4.16 to 16/27.6 kV
[See Rule 75-244(3).]

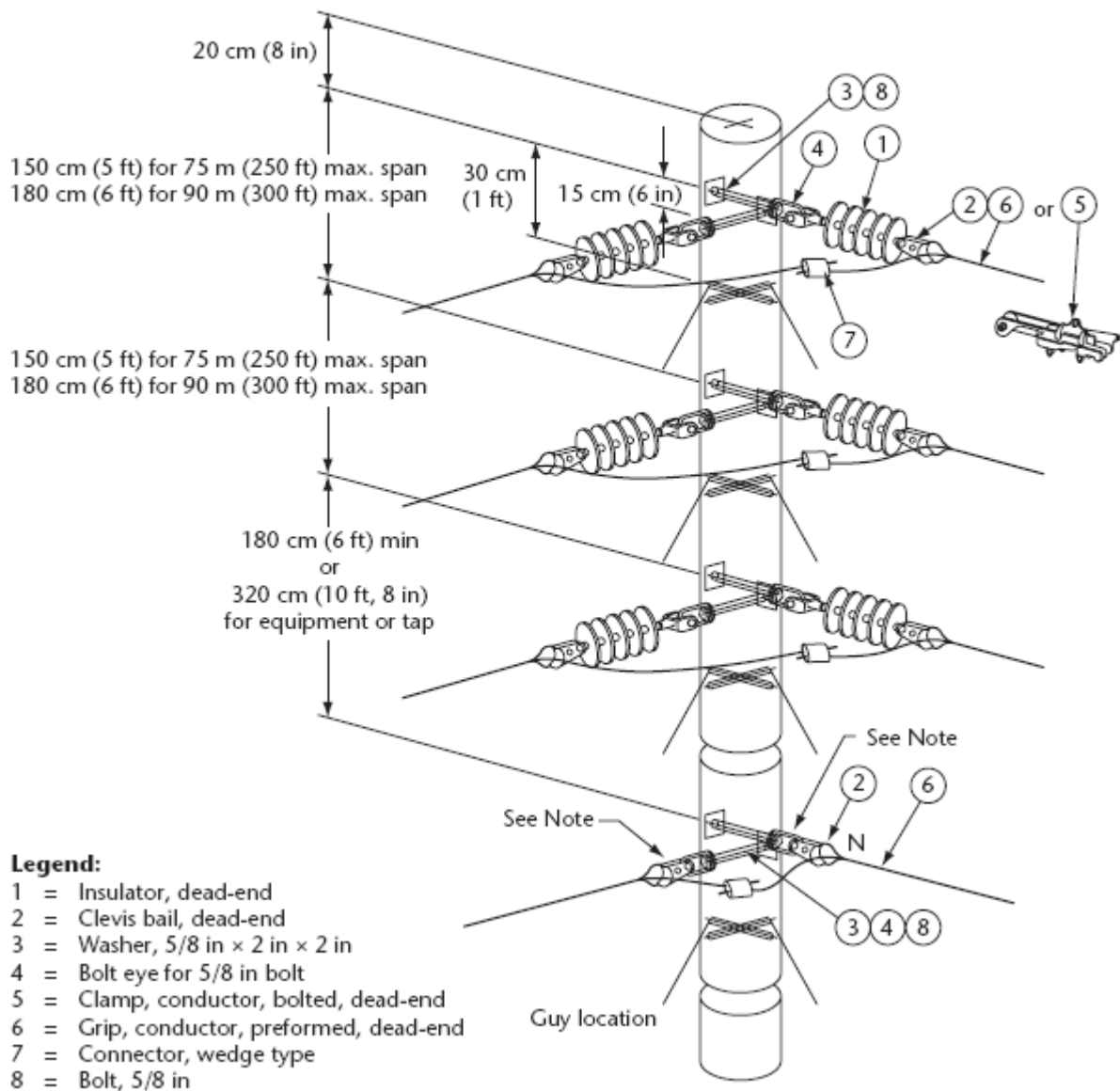



For Your Safety

**Specification 14.1
Primary 3-phase, tangent, crossarm (LP insulator)
3-phase, 2.4/4.16 to 16/27.6 kV
[See Rule 75-244(3).]**

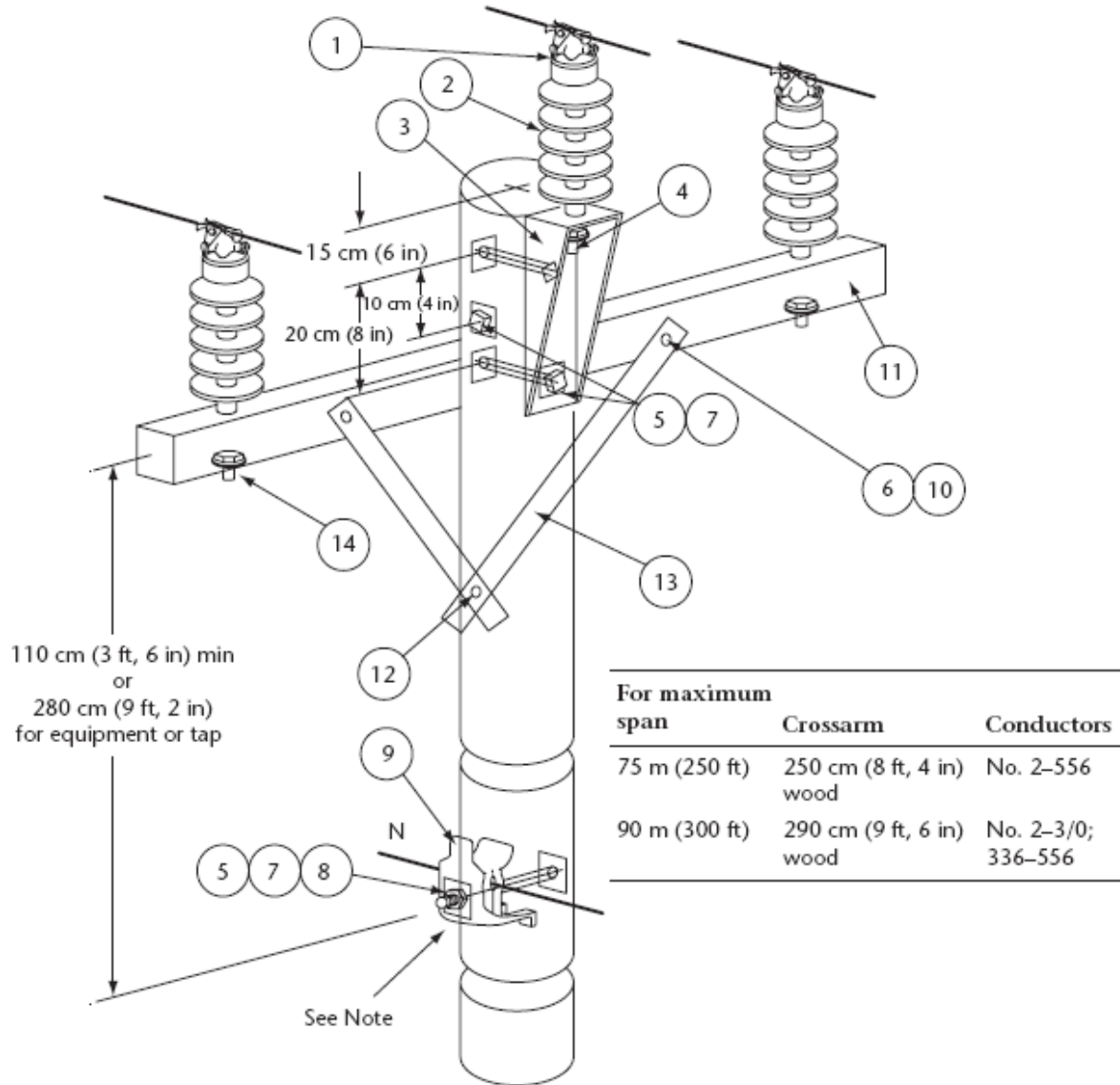

Legend:

- 1 = Clamp, conductor, insulator
- 2 = Insulator, vertical
- 3 = Bracket, pole top, tangent
- 4 = Stud insulator, 5/8 in x 3 in
- 5 = Bolt, 5/8 in
- 6 = Bolt, 3/8 in
- 7 = Washer, 5/8 in x 2 in x 2 in
- 8 = Lockwasher for 5/8 in bolt
- 9 = Clamp, neutral conductor
- 10 = Washer, rd. 3/8 in
- 11 = Crossarm, wood (see span)
- 12 = Screw, lag 1/2 in x 4-1/2 in
- 13 = Brace
- 14 = Stud insulator, 5/8 in x 7 in

Note: See Specification 35, Figure 2.



For Your Safety

Specification 14.2
Primary 3-phase, line angle 4° to 15° crossarm
(LP insulator) 3-phase, 2.4/4.16 to 16/27.6 kV
 [See Rule 75-244(3).]

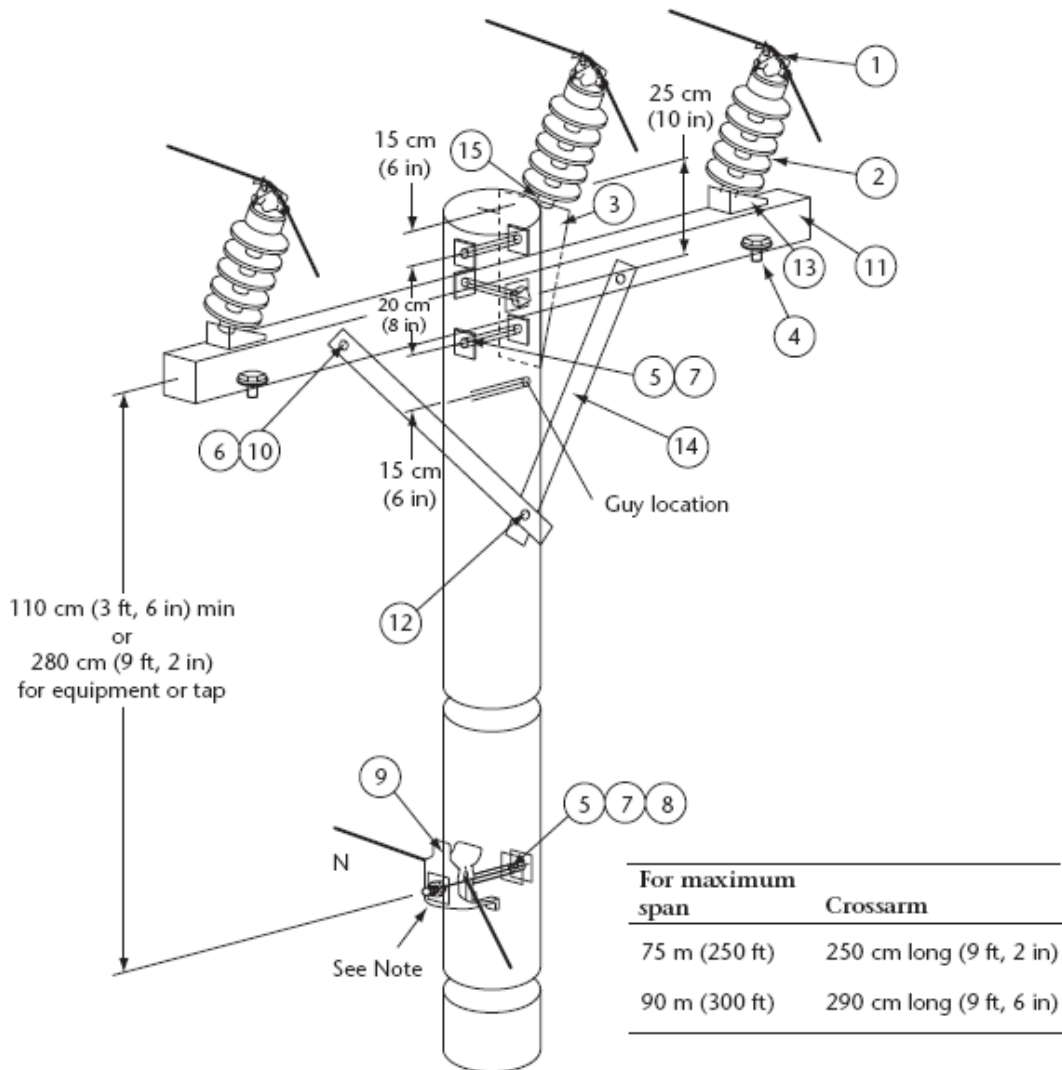

Legend:

- | | |
|-----------------------------------|-------------------------------------|
| 1 = Clamp, conductor, insulator | 9 = Clamp, neutral conductor |
| 2 = Insulator, vertical, 35 kV | 10 = Washer, rd. 3/8 in |
| 3 = Bracket, angle | 11 = Crossarm, wood (see span) |
| 4 = Stud insulator, 5/8 in x 3 in | 12 = Screw, lag 1/2 in x 4-1/2 in |
| 5 = Bolt, 5/8 in | 13 = Bracket, insulator angle mount |
| 6 = Bolt, 3/8 in | 14 = Brace |
| 7 = Washer, 5/8 in x 2 in x 2 in | 15 = Stud insulator, 5/8 in x 3 in |
| 8 = Lockwasher for 5/8 in bolt | |

Note: See Specification 35, Figure 1.



For Your Safety

**Specification 14.3
Primary 3-phase dead-end, crossarm (triangular)
3-phase, 2.4/4.16 to 16/27.6 kV
[See Rule 75-244(3).]**

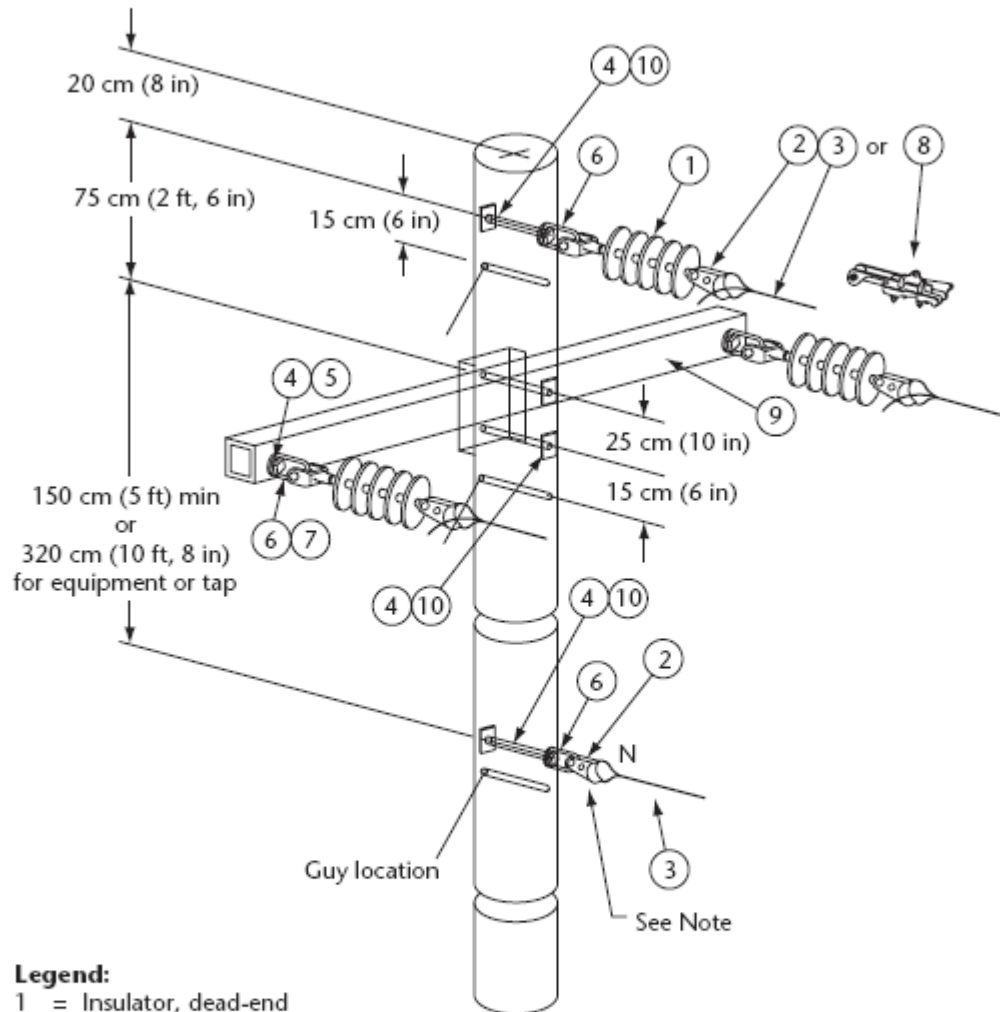

Legend:

- 1 = Insulator, dead-end
- 2 = Clevis bail, dead-end
- 3 = Grip, conductor, preformed, dead-end
- 4 = Washer, 5/8 in × 2 in × 2 in
- 5 = Lockwasher for 5/8 in bolt
- 6 = Bolt eye for 5/8 in bolt
- 7 = Bolt, 5/8 in
- 8 = Clamp, conductor, bolted, dead-end
- 9 = Crossarm (see span)
- 10 = Bolt, 5/8 in × 6 in

| For maximum span | Crossarm |
|------------------|--------------------------------------|
| 75 m (250 ft) | 170 cm (5 ft, 8 in) steel or wood |
| 90 m (300 ft) | 230 cm (7 ft, 6 in) steel or wood |

Note: See Specification 35, Figure 1.



For Your Safety

Specification 14.4
Primary 3-phase dead-end, crossarm (flat)
3-phase, 2.4/4.16 to 16/27.6 kV
 [See Rule 75-244(3).]

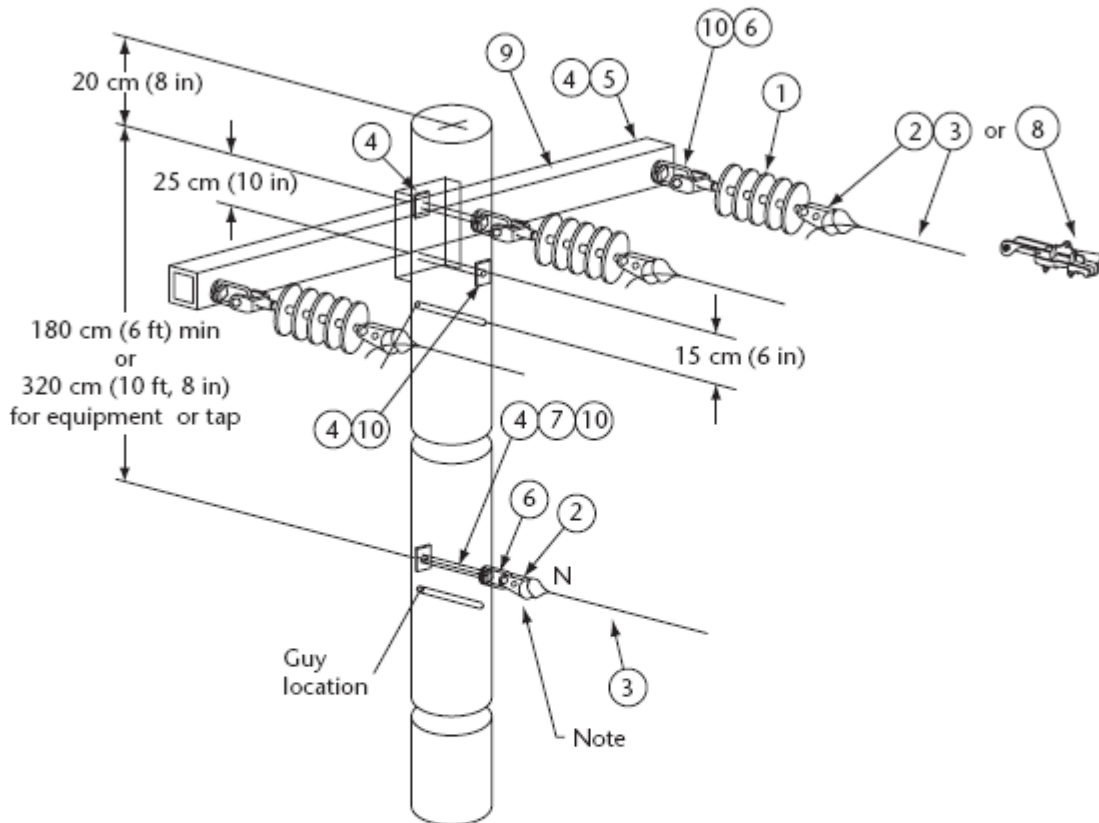

Legend:

- 1 = Insulator, dead-end
- 2 = Clevis bail, dead-end
- 3 = Grip, conductor, preformed, dead-end
- 4 = Washer, 5/8 in × 2 in × 2 in
- 5 = Lockwasher for 5/8 in bolt
- 6 = Bolt eye for 5/8 in bolt
- 7 = Bolt, 5/8 in
- 8 = Clamp, conductor, bolted, dead-end
- 9 = Crossarm (see span)
- 10 = Bolt, 5/8 in × 6 in

Note: See Specification 35, Figure 1.

| For maximum span | Crossarm |
|------------------|--------------------------------------|
| 75 m (250 ft) | 230 cm (7 ft, 6 in) steel or wood |
| 90 m (300 ft) | 290 cm (9 ft, 6 in) steel |



For Your Safety

Specification 15.1
Primary 3-phase underbuilt, tangent or line angle 0° to 15°
3-phase, 2.4/4.16 to 16/27.6 kV
[See Rule 75-244(3).]

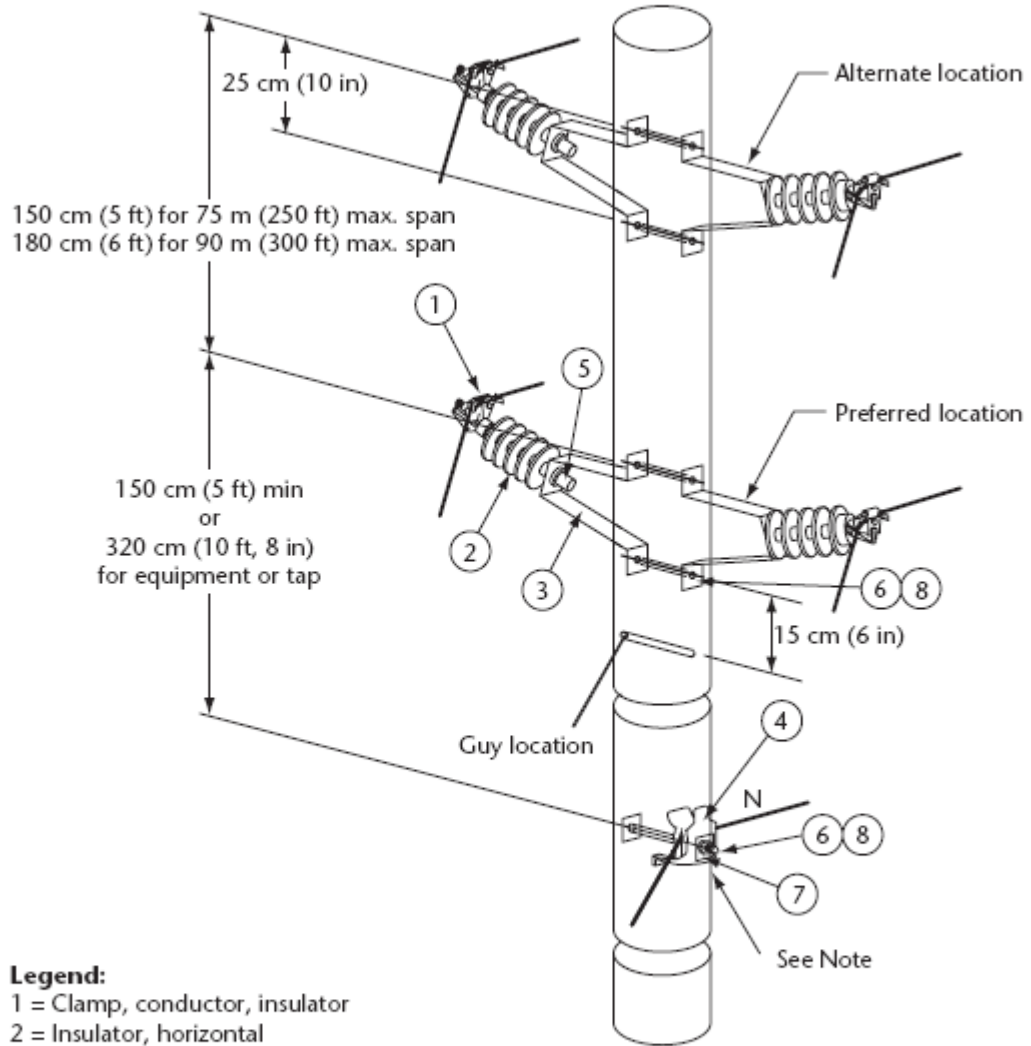

- Legend:**
- 1 = Clamp, conductor, insulator
 - 2 = Insulator, horizontal
 - 3 = Bracket, stand-off (see span)
 - 4 = Clamp, neutral conductor
 - 5 = Stud, insulator
 - 6 = Bolt, 5/8 in
 - 7 = Lockwasher for 5/8 in bolt
 - 8 = Washer, 5/8 in x 2 in x 2 in

Note: See Specification 35, Figure 1.

| For maximum span | Stand-off bracket |
|------------------|-------------------|
| 75 m (250 ft) | 23 cm (9 in) |
| 90 m (300 ft) | 45 cm (18 in) |



For Your Safety

Specification 15.2
Primary 3-phase, underbuilt tangent crossarm (LP insulator)
3-phase, 2.4/4.16 to 16/27.6 kV, maximum span 60 m (200 ft)
[See Rule 75-244(3).]

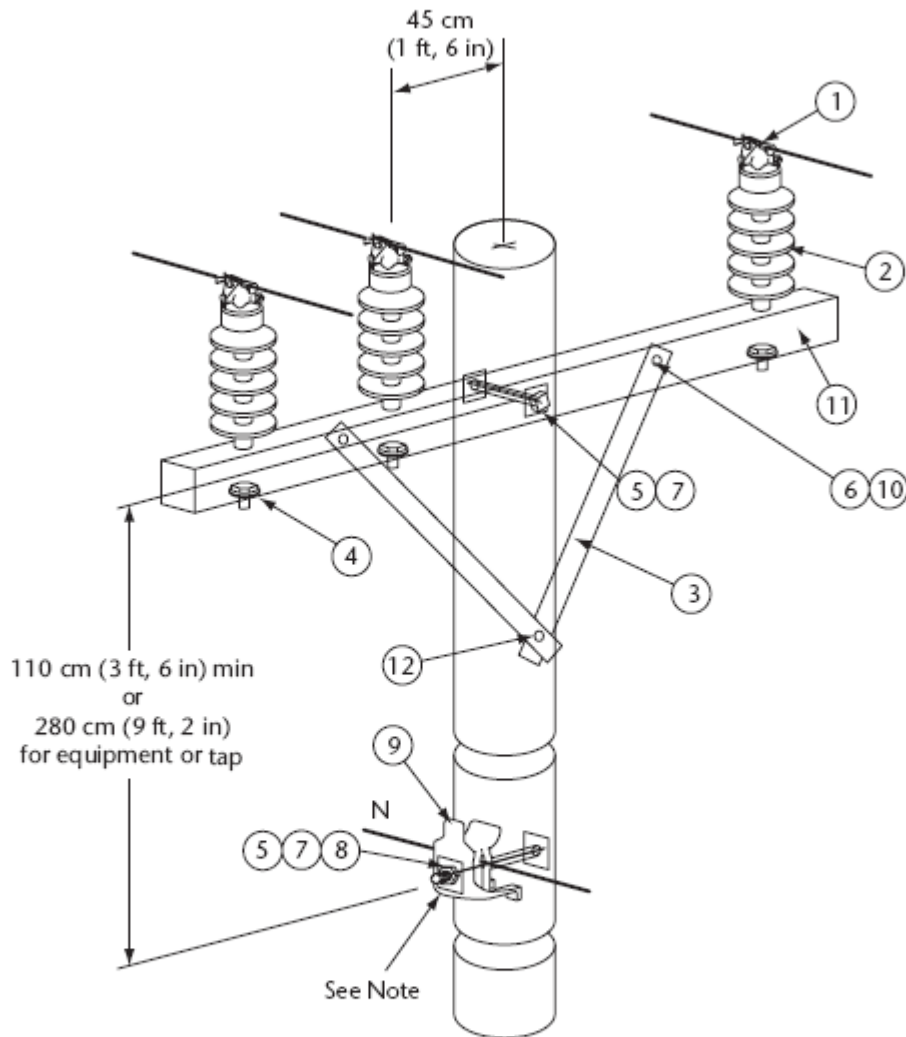

Legend:

- | | |
|-----------------------------------|-----------------------------------|
| 1 = Clamp, conductor, insulator | 7 = Washer, 5/8 in × 2 in × 2 in |
| 2 = Insulator, vertical | 8 = Lockwasher for 5/8 in bolt |
| 3 = Brace | 9 = Clamp, neutral conductor |
| 4 = Stud insulator, 5/8 in × 7 in | 10 = Washer, rd. 3/8 in |
| 5 = Bolt, 5/8 in | 11 = Crossarm, wood, 9 ft, 10 in |
| 6 = Bolt, 3/8 in | 12 = Screw, lag 1/2 in × 4-1/2 in |

Note: See Specification 35, Figure 2.



For Your Safety

Specification 15.3
Primary 3-phase, underbuilt, line angle 4° to 15° crossarm
(LP insulator) 3-phase, 2.4/4.16 to 16/27.6 kV, maximum span 60 m
[See Rule 75-244(3).]

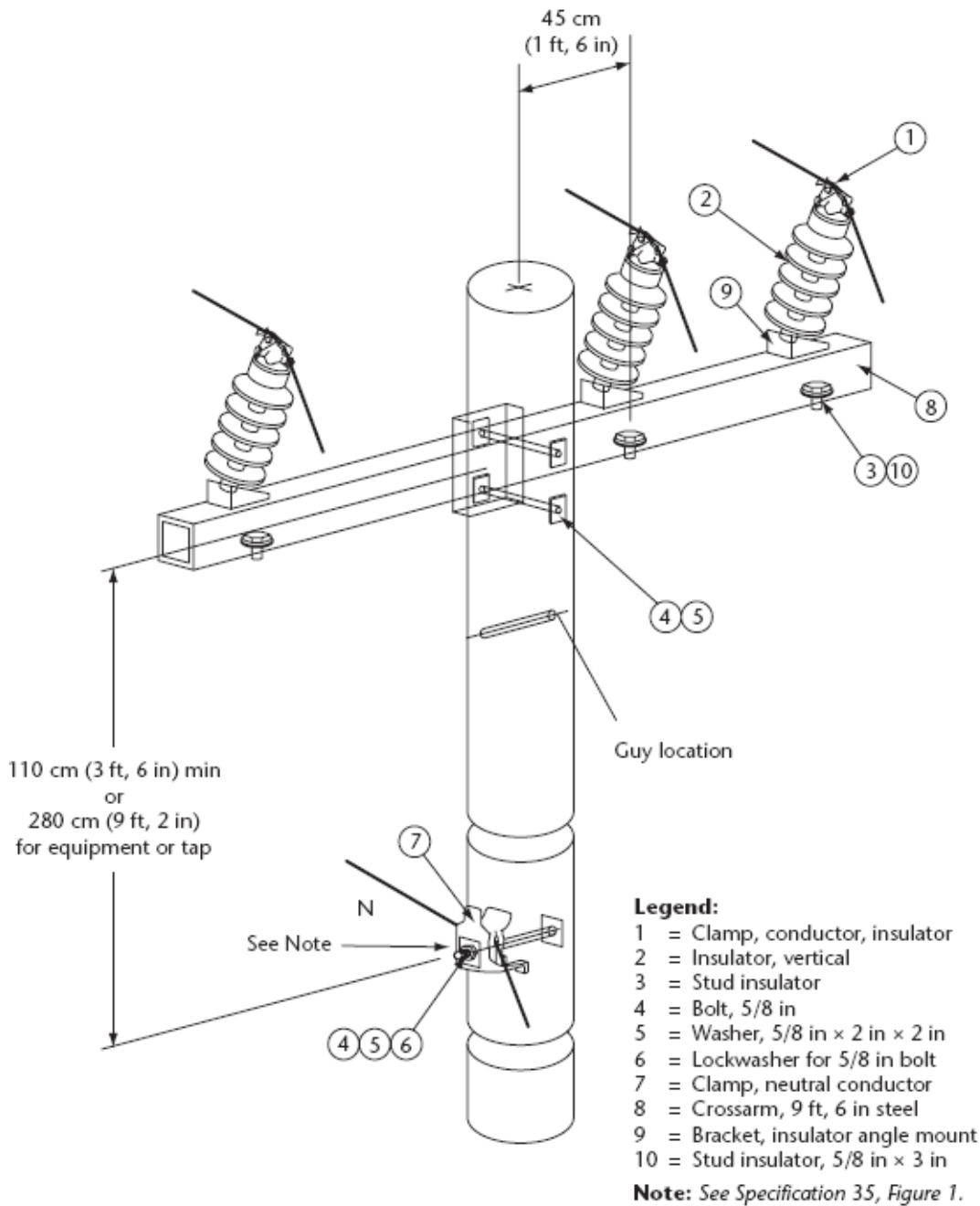



For Your Safety

Specification 16.1
Subtransmission 3-phase tangent, 3-phase, 44 kV
[See Rule 75-244(3).]

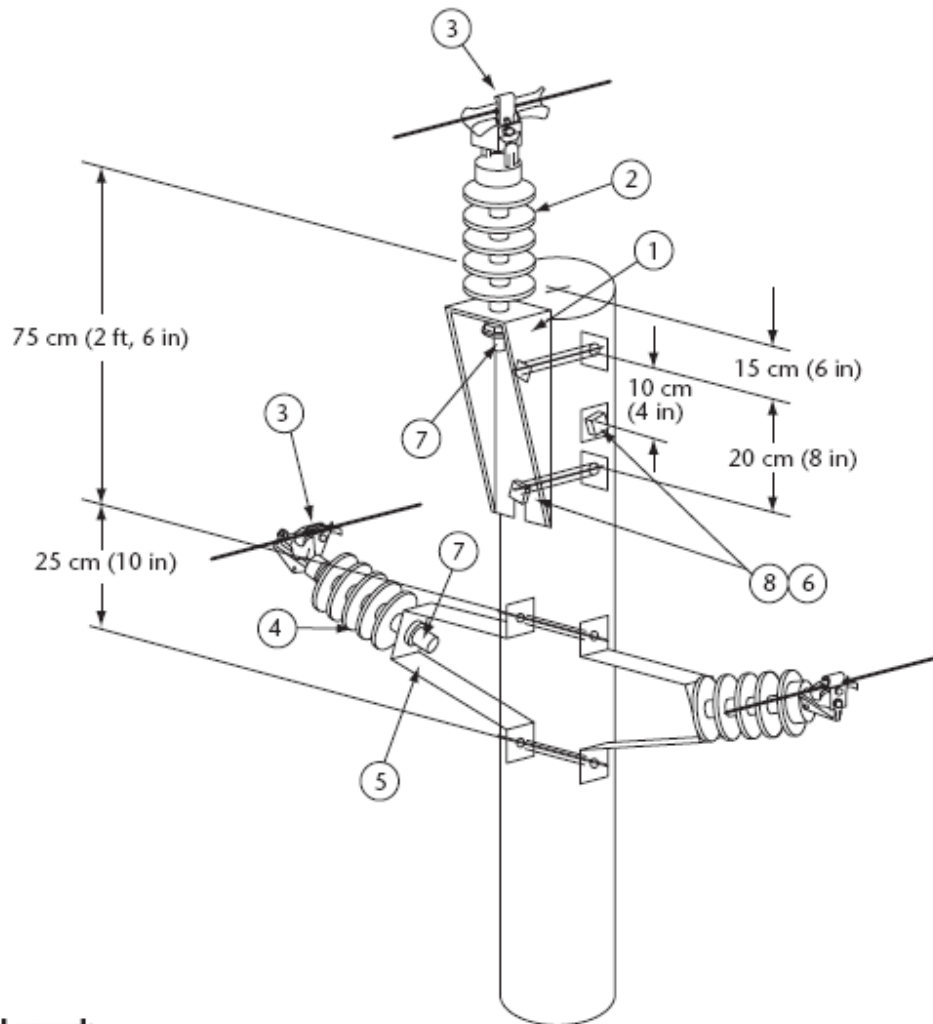

Legend:

- 1 = Bracket pole top, tangent
- 2 = Insulator, vertical
- 3 = Clamp, conductor, insulator
- 4 = Insulator, horizontal
- 5 = Bracket, stand-off (see span)
- 6 = Washer, 5/8 in × 2 in × 2 in
- 7 = Stud, insulator
- 8 = Bolt, 5/8 in

| For maximum span | Stand-off bracket |
|------------------|-------------------|
| 75 m (250 ft) | 23 cm (9 in) |
| 90 m (300 ft) | 45 cm (18 in) |

Specification 16.2
Subtransmission 3-phase dead-end, vertical 3-phase, 44 kV
[See Rule 75-244(3).]

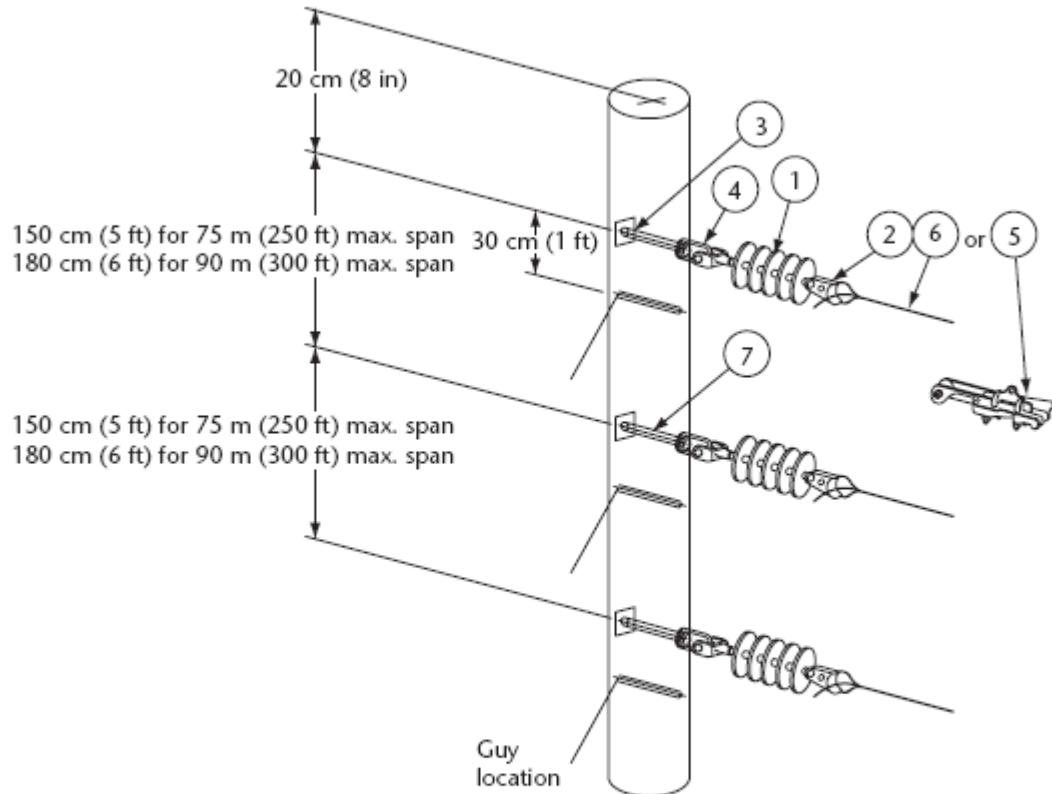

Legend:

- 1 = Insulator, dead-end
- 2 = Clevis bail, dead-end
- 3 = Washer, 5/8 in × 2 in × 2 in
- 4 = Bolt eye for 5/8 in bolt
- 5 = Clamp, conductor, bolted, dead-end
- 6 = Grip, conductor, preformed, dead-end
- 7 = Bolt, 5/8 in



For Your Safety

Specification 17.1
Subtransmission 3-phase, line angle 4° to 15°
3-phase, 44 kV
[See Rule 75-244(3).]

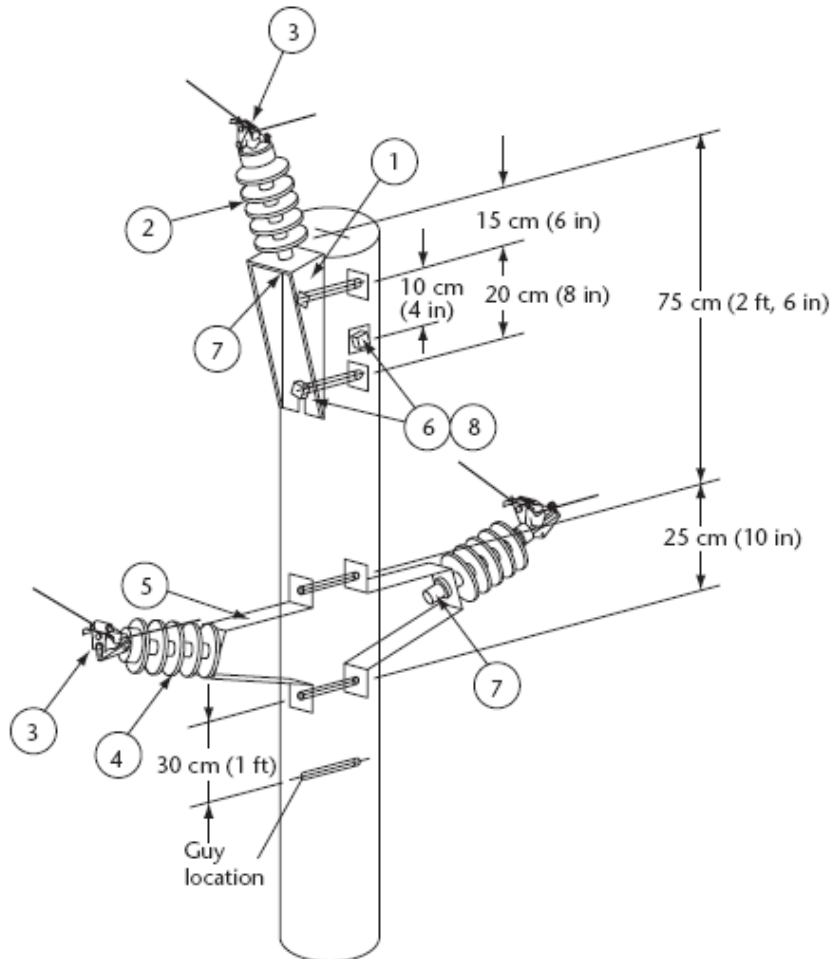

Legend:

- 1 = Bracket pole top, angle
- 2 = Insulator, vertical
- 3 = Clamp, conductor, insulator
- 4 = Insulator, horizontal
- 5 = Bracket, stand-off (see span)
- 6 = Washer, 5/8 in x 2 in x 2 in
- 7 = Stud, insulator
- 8 = Bolt, 5/8 in

| For maximum span | Stand-off bracket |
|------------------|-------------------|
| 75 m (250 ft) | 23 cm (9 in) |
| 90 m (300 ft) | 45 cm (18 in) |

For Your Safety

Specification 17.2
Subtransmission 3-phase line angle 16° to 45°
3-phase, 44 kV
[See Rule 75-244(3).]

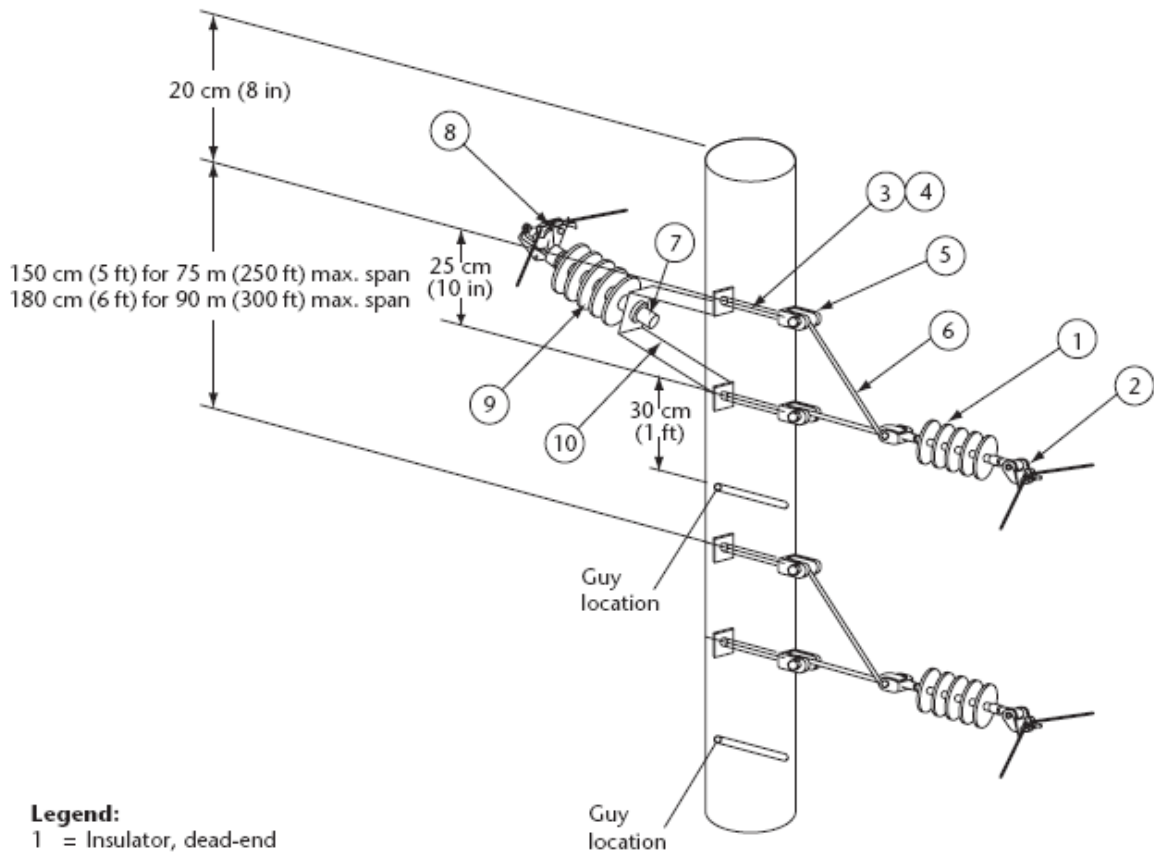

Legend:

- 1 = Insulator, dead-end
- 2 = Clamp, conductor, angle
- 3 = Washer, 5/8 in × 2 in × 2 in
- 4 = Bolt, 5/8 in
- 5 = Clevis, bolt head for 5/8 in bolt
- 6 = Bracket, suspension
- 7 = Stud, insulator
- 8 = Clamp, conductor, insulator
- 9 = Insulator, vertical
- 10 = Bracket, stand-off (see span)

| For maximum span | Stand-off bracket |
|------------------|-------------------|
| 75 m (250 ft) | 23 cm (9 in) |
| 90 m (300 ft) | 45 cm (18 in) |

For Your Safety

Specification 17.3
Subtransmission 3-phase, line angle 16° to 60°
3-phase, 44 kV
 [See Rule 75-244(3).]

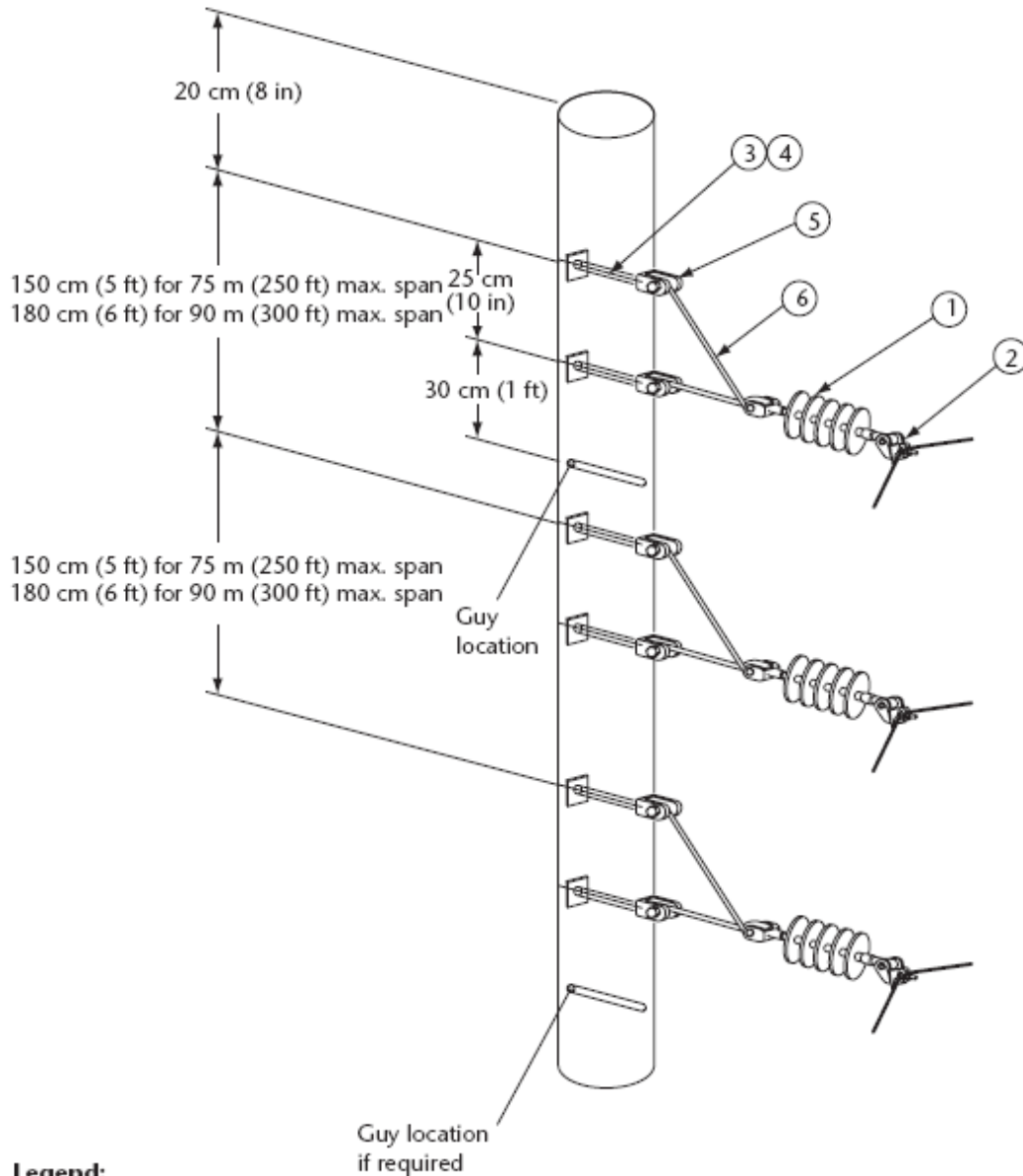

- Legend:**
- 1 = Insulator, dead-end
 - 2 = Clamp, conductor, angle
 - 3 = Washer, 5/8 in × 2 in × 2 in
 - 4 = Bolt, 5/8 in
 - 5 = Clevis, bolt head for 5/8 in bolt
 - 6 = Bracket, suspension



For Your Safety

Specification 17.4
Subtransmission 3-phase, line angle 61° to 90°
3-phase, 44 kV
[See Rule 75-244(3).]

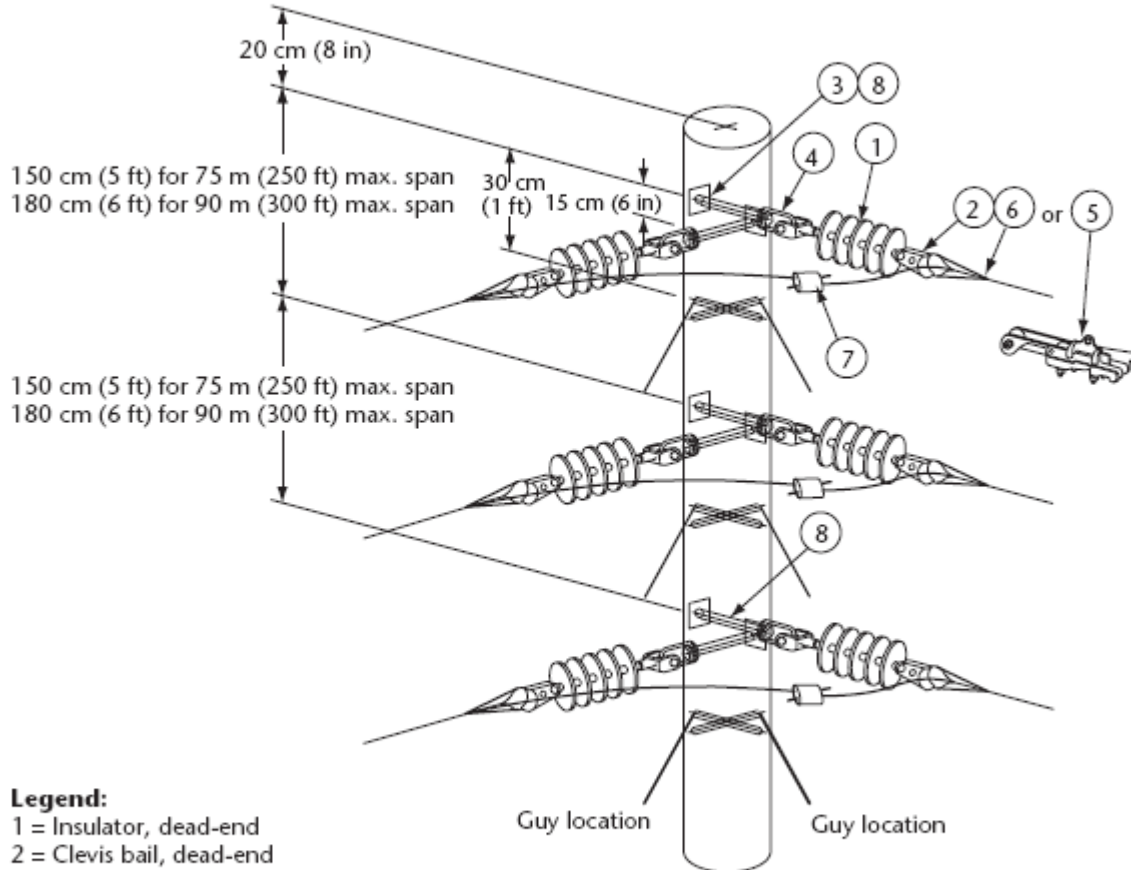

- Legend:**
- 1 = Insulator, dead-end
 - 2 = Clevis bail, dead-end
 - 3 = Washer, 5/8 in × 2 in × 2 in
 - 4 = Bolt eye for 5/8 in bolt
 - 5 = Clamp, conductor, bolted, dead-end
 - 6 = Grip, conductor, preformed, dead-end
 - 7 = Connector, wedge type
 - 8 = Bolt, 5/8 in



For Your Safety

Specification 18.1
Primary 3-phase tangent, crossarm 3-phase,
44 kV maximum span 90 m (300 ft)
[See Rule 75-244(3).]

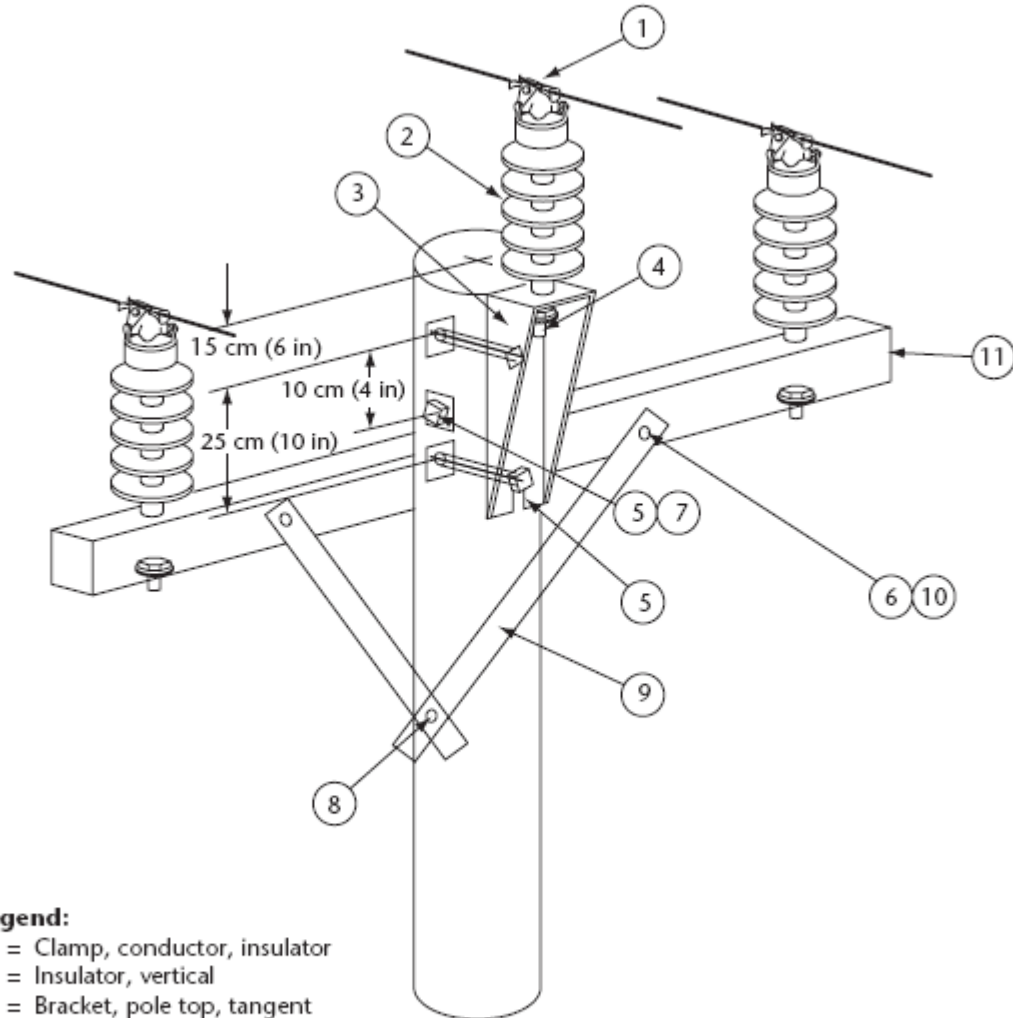

Legend:

- 1 = Clamp, conductor, insulator
- 2 = Insulator, vertical
- 3 = Bracket, pole top, tangent
- 4 = Stud, insulator
- 5 = Bolt, 5/8 in
- 6 = Bolt, 3/8 in
- 7 = Washer, 5/8 in x 2 in x 2 in
- 8 = Screw, lag 1/2 in x 4-1/2 in
- 9 = Brace
- 10 = Washer, rd. 3/8 in
- 11 = Crossarm, wood 9 ft, 10 in



For Your Safety

Specification 18.2
Primary 3-phase, line angle 4° to 15°, crossarm 3-phase,
44 kV maximum span 90 m (300 ft)
[See Rule 75-244(3).]

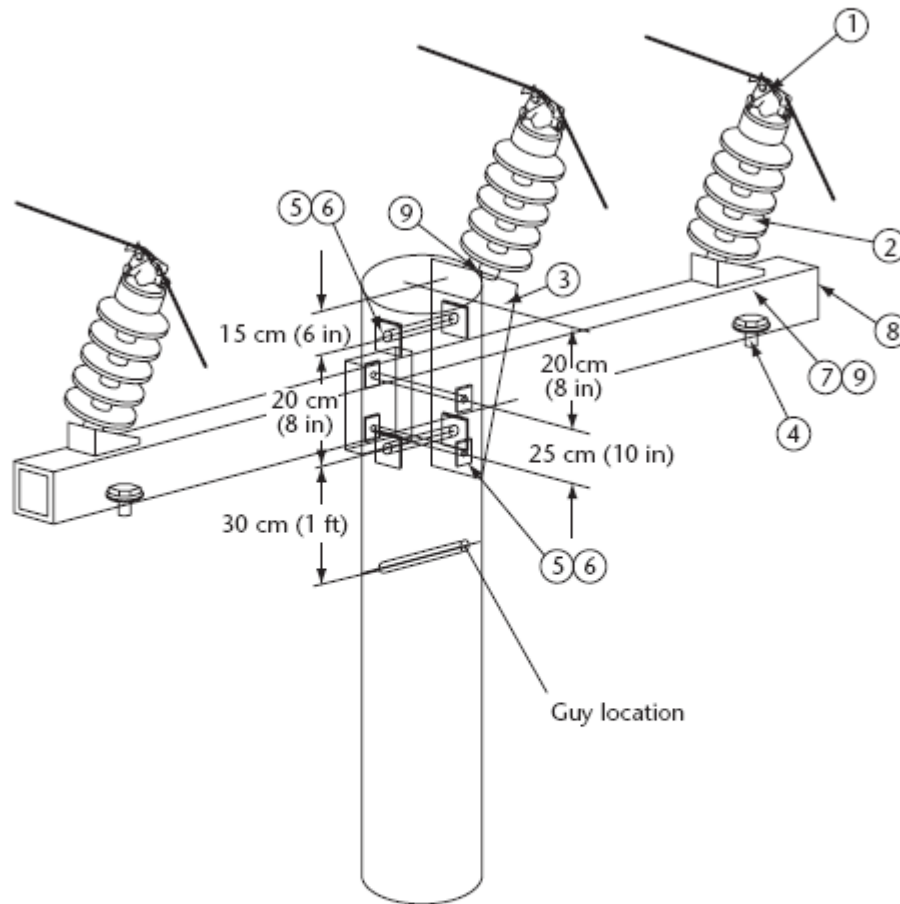

- Legend:**
- 1 = Clamp, conductor, insulator
 - 2 = Insulator, vertical
 - 3 = Bracket, pole top, angle
 - 4 = Stud insulator, 5/8 in x 7 in
 - 5 = Bolt, 5/8 in
 - 6 = Washer, 5/8 in x 2 in x 2 in
 - 7 = Bracket, insulator angle mount
 - 8 = Crossarm, steel 9 ft, 6 in
 - 9 = Stud, post insulator 5/8 in x 3 in



For Your Safety

Specification 18.3
Primary 3-phase dead-end, crossarm (triangular) 3-phase, 44 kV
 [See Rule 75-244(3).]

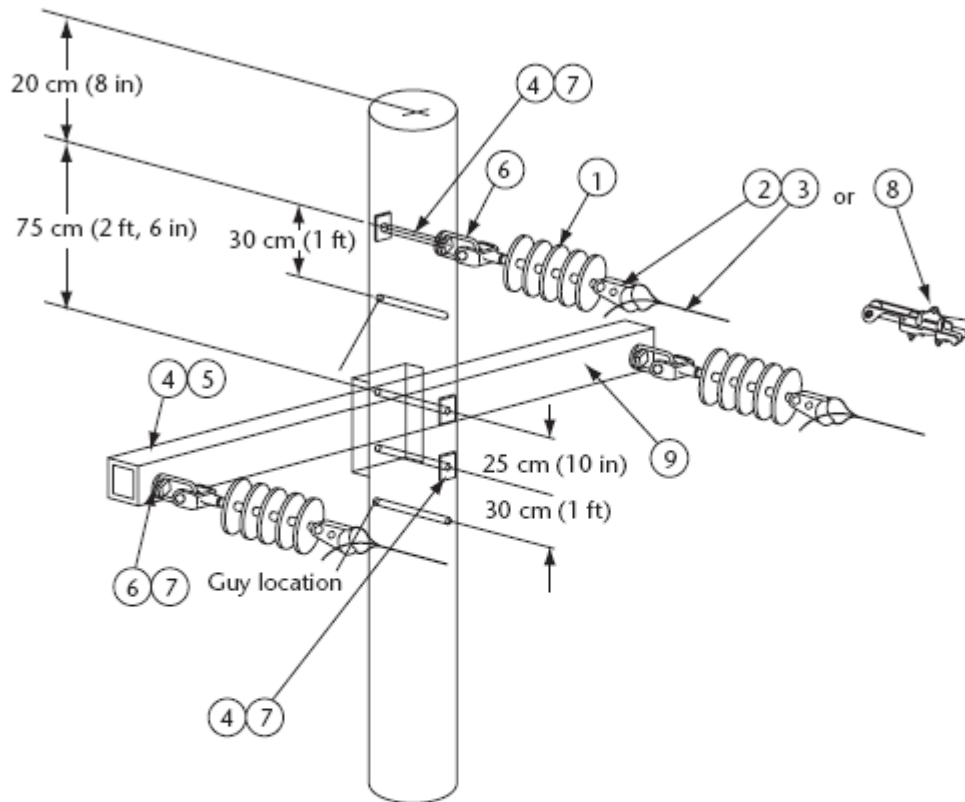

Legend:

- 1 = Insulator, dead-end
- 2 = Clevis bail, dead-end
- 3 = Grip, conductor, preformed, dead-end
- 4 = Washer, 5/8 in x 2 in x 2 in
- 5 = Lockwasher, 5/8 in
- 6 = Bolt eye for 5/8 in bolt
- 7 = Bolt, 5/8 in
- 8 = Clamp, conductor, bolted, dead-end
- 9 = Crossarm (see span)

| For maximum span | Crossarm |
|------------------|--------------------------------------|
| 75 m (250 ft) | 170 cm (5 ft, 6 in) steel or wood |
| 90 m (300 ft) | 230 cm (7 ft, 6 in) steel or wood |



For Your Safety

Specification 18.4
Primary 3-phase dead-end, crossarm (flat) 3-phase, 44 kV
[See Rule 75-244(3).]

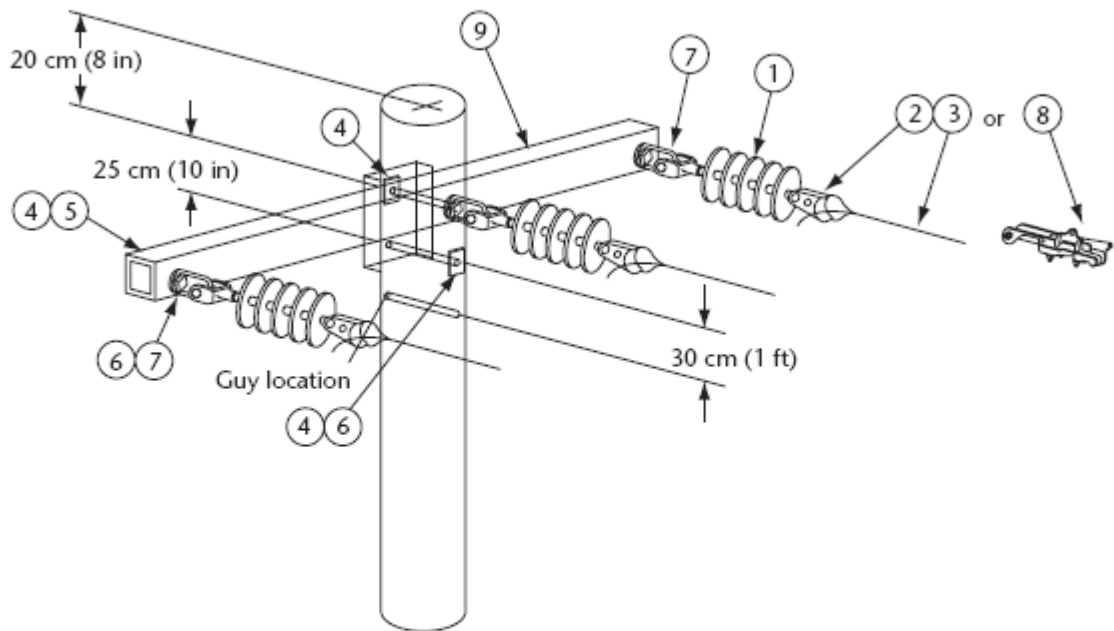

Legend:

- 1 = Insulator, dead-end
- 2 = Clevis bail, dead-end
- 3 = Grip, conductor, preformed, dead-end
- 4 = Washer, 5/8 in x 2 in x 2 in
- 5 = Lockwasher for 5/8 in bolt
- 6 = Bolt, 5/8 in
- 7 = Bolt eye for 5/8 in bolt
- 8 = Clamp, conductor, bolted, dead-end
- 9 = Crossarm (see span)

| For maximum span | Crossarm |
|------------------|--------------------------------------|
| 75 m (250 ft) | 230 cm (7 ft, 6 in) steel or wood |
| 90 m (300 ft) | 290 cm (9 ft, 6 in) steel |



For Your Safety

**Specification 19
Steel plate anchor in soil**

[See Rule 75-246(1)(a).]

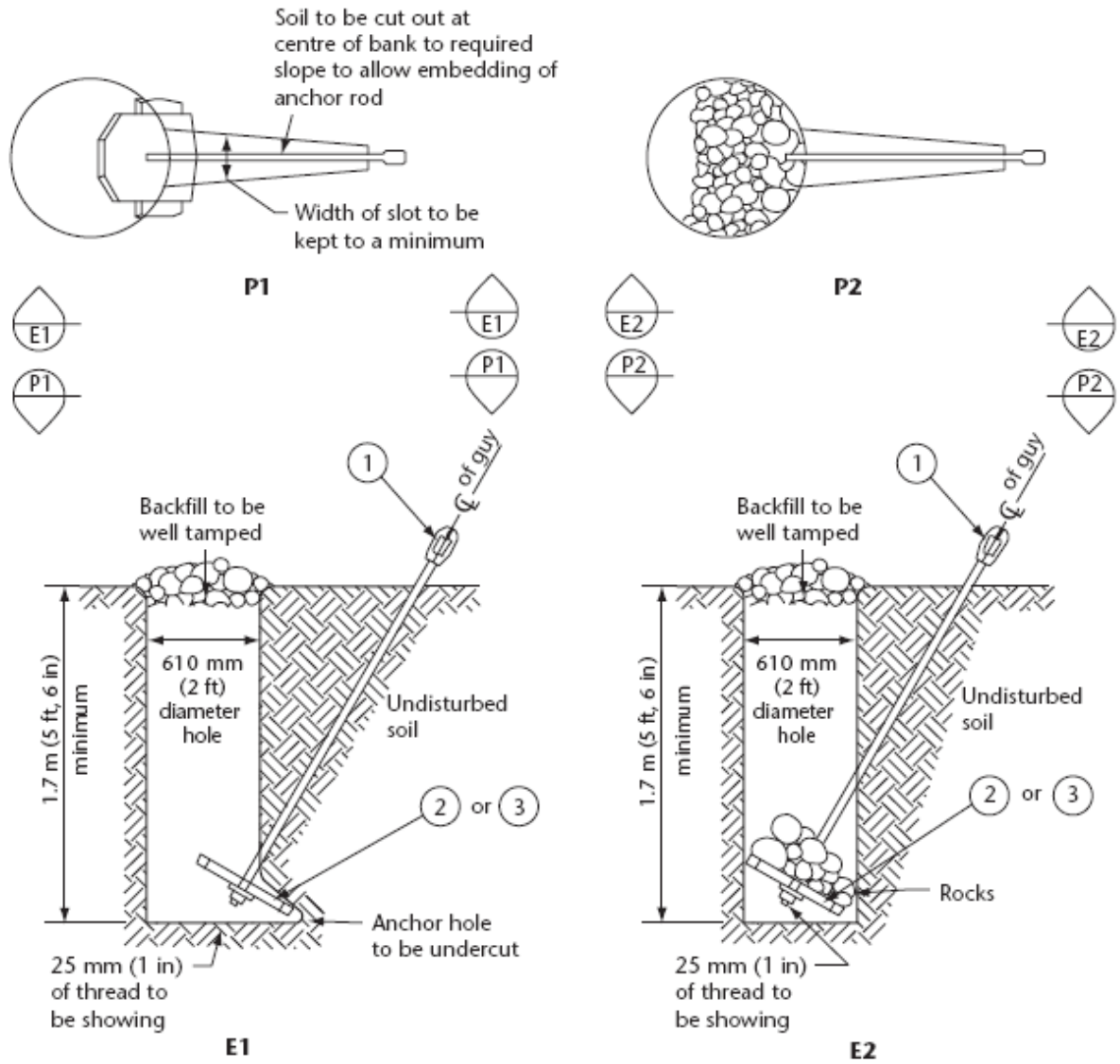

**Figure 1
Anchor hole with undercut**

**Figure 2
Anchor hole without undercut**

Legend:

- 1 = Rod, anchor 3/4 in x 8 ft
- 2 = Anchor steel plate, 20 in
- 3 = Anchor steel plate, 24 in



For Your Safety

Specification 20
Log (slug) anchor in soil
[See Rule 75-246(1)(b).]

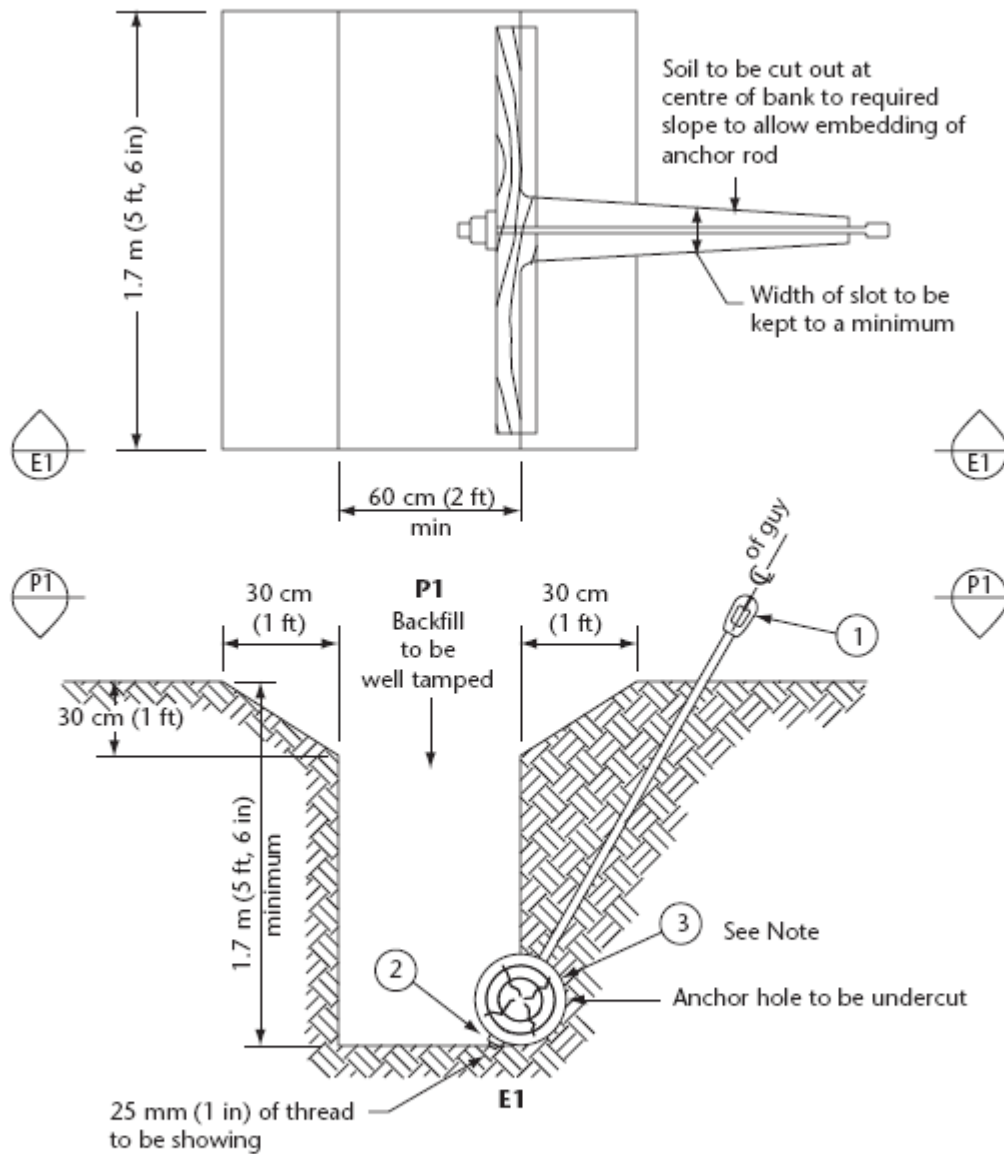

Legend:

- 1 = Rod, anchor 3/4 in x 8 ft
- 2 = Washer, 3/4 in x 4 in x 4 in
- 3 = Log, anchor 8 in diameter x 5 ft

Note: Logs shall be either cedar or treated pine.



For Your Safety

**Specification 21
Expansion anchor in soil**

[See Rule 75-246(1)(c).]

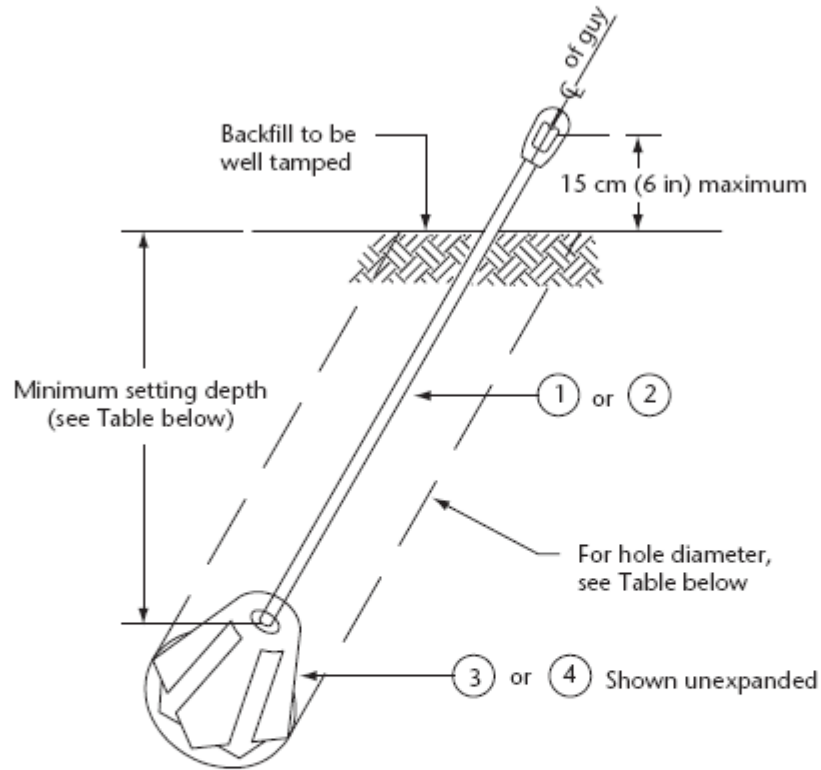

| Anchor diameter | Rod diameter | Minimum setting depth | Hole diameter |
|-----------------|----------------|-----------------------|------------------|
| 200 mm (8 in) | 20 mm (3/4 in) | 1.7 m (66 in) | 210 mm (8.5 in) |
| 300 mm (12 in) | 25 mm (1 in) | 2.4 m (94 in) | 310 mm (12.5 in) |

Legend:

- 1 = Rod, anchor 3/4 in × 8 ft, 0 in
- 2 = Rod, anchor 1 in × 10 ft, 0 in
- 3 = Anchor, expansion 8 in
- 4 = Anchor, expansion 12 in



For Your Safety

Specification 22
Earth screw anchor
[See Rule 75-246(1)(d).]

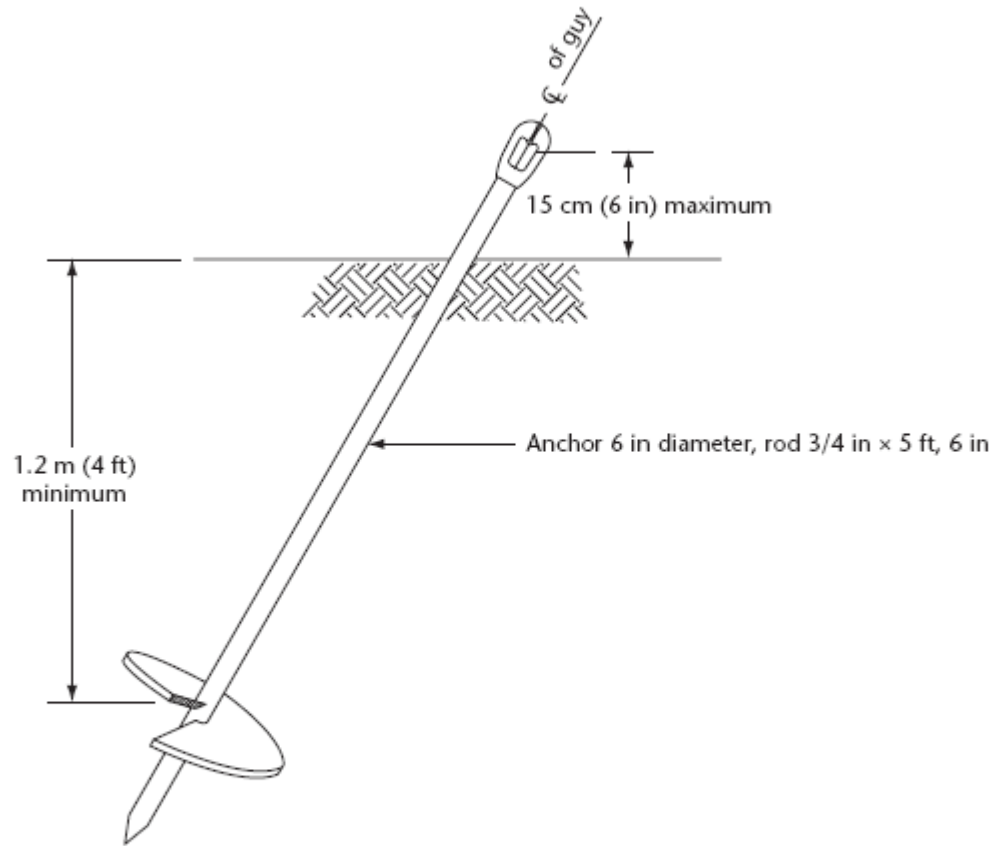

Note: *This anchor shall be used for secondary services or storm guying in average or better soil only.*



For Your Safety

**Specification 23
Rock (solid hard) anchor**

[See Rule 75-246(2)(a).]

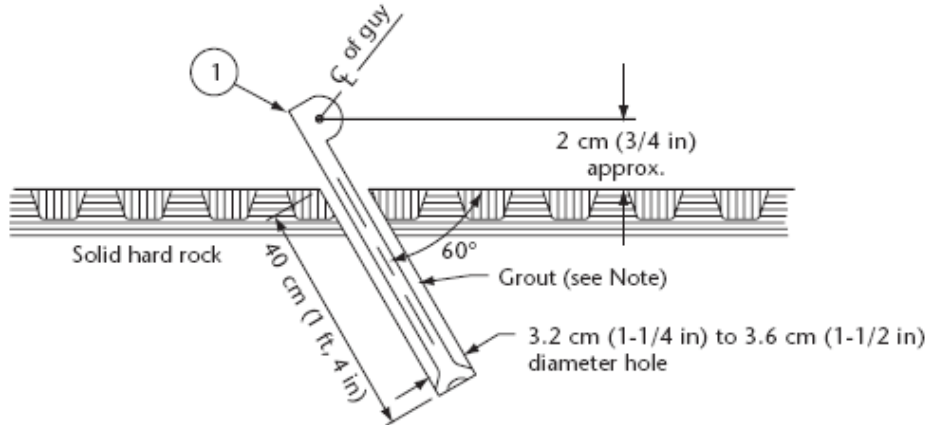

**Figure 1
Rock anchor without earth overburden**

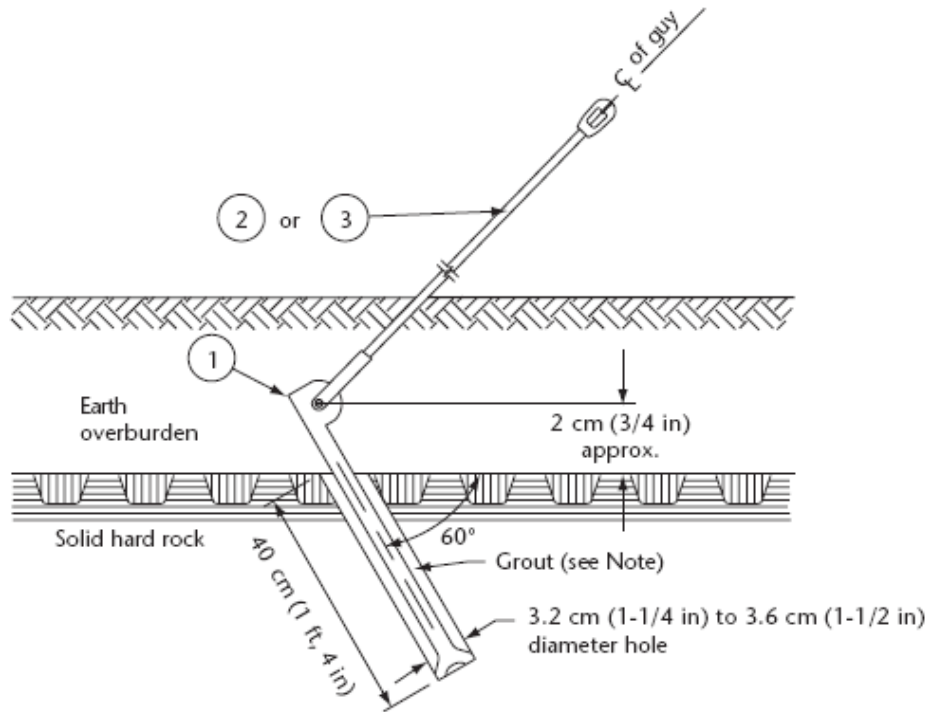

**Figure 2
Rock anchor with earth overburden**

Legend:

- 1 = Anchor, rock with wedge, 18 in
- 2 = Extension, rock anchor 5/8 in x 3 ft
- 3 = Extension, rock anchor 5/8 in x 5 ft

Note: Grout to be installed as per manufacturer's recommendation.



For Your Safety

**Specification 24
Shale and limestone anchor**

[See Rule 75-246(2)(b).]

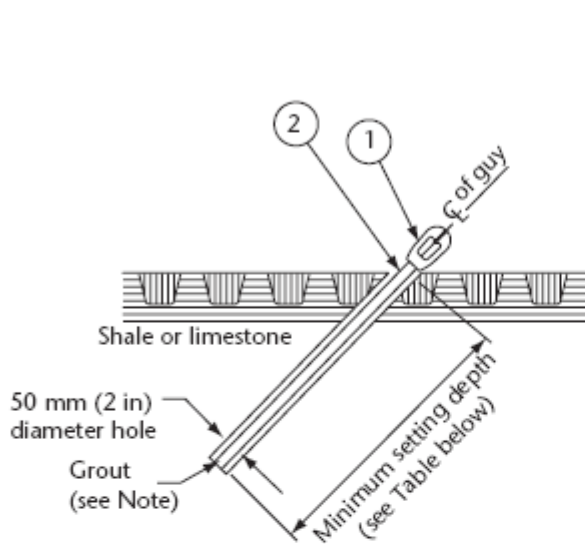

**Figure 1
Shale and limestone anchor
without earth overburden**

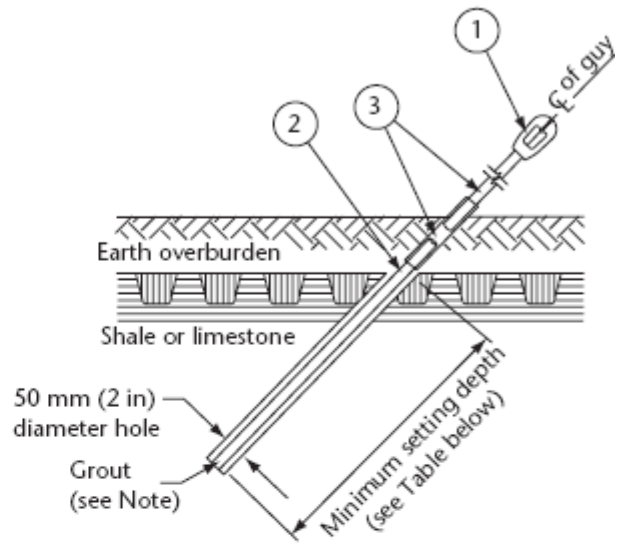

**Figure 2
Shale and limestone anchor
with earth overburden**

| Type of rock | Minimum setting depth |
|--------------------------|-----------------------|
| Sound massive limestone | 1.0 m (3 ft, 4 in) |
| Thickly bedded limestone | 1.25 m (4 ft) |
| Thinly bedded limestone | 1.75 m (5 ft, 8 in) |
| Shale | 2.0 m (6 ft, 8 in) |

Legend:

- 1 = Anchor, triple eye nut
- 2 = Anchor bar, deformed, 1 in diameter x 6 ft, 9 in
- 3 = Anchor rod, 1 in x 3 ft, 6 in

Note: Grout to be installed as per manufacturer's recommendation.



For Your Safety

Specification 25
**Location of guy strain insulator joint use
and non-joint use, armless or crossarm**
(See Rules 75-248(2), 75-250, and 75-254.)

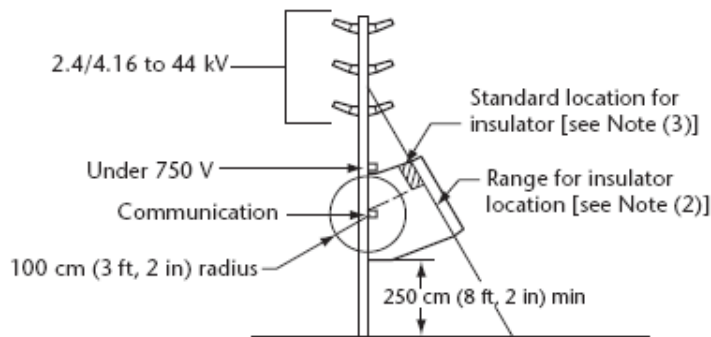

Down guy

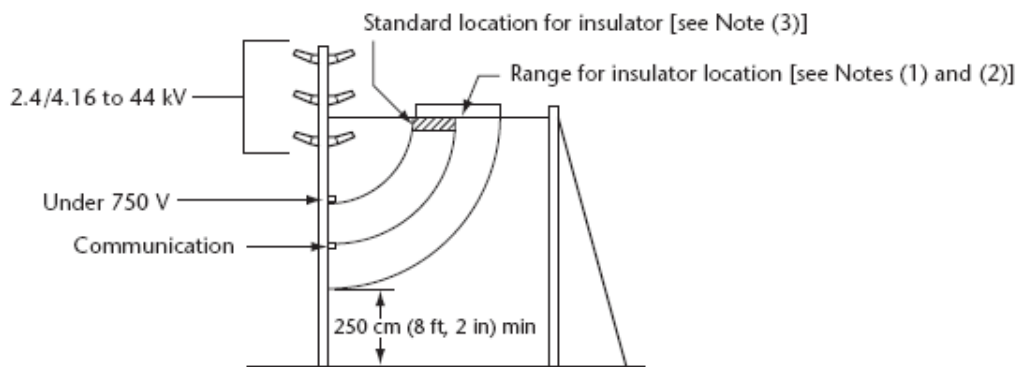

Span guy

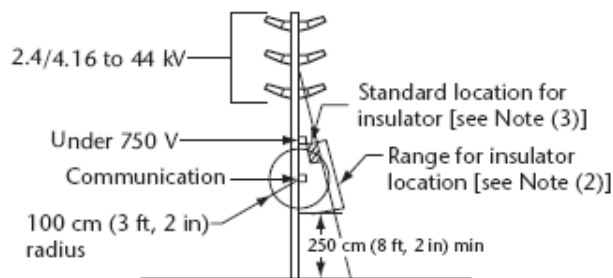

Down guy

Guy passing within 100 cm (3 ft, 2 in) of communication circuit

Notes:

- (1) A second insulator is required if the power circuit of a separate line is crossing above or below the span guy. This second insulator should be located so as to isolate the section of the span guy that is exposed to the crossing circuit.
- (2) The insulator shall fall below all power attachments (including neutral) under broken guy conditions, and it should be a minimum of 200 cm (6 ft, 8 in) (where possible) from the pole attachment.
- (3) If communication (telephone or TV cable) connections are on the pole, the guy insulator shall be in the standard location as shown.

**Specification 26
Typical guy arrangements**

[See Rules 75-248(2) and 75-252.]

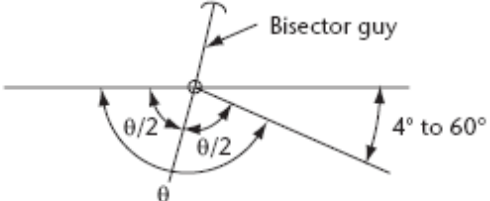
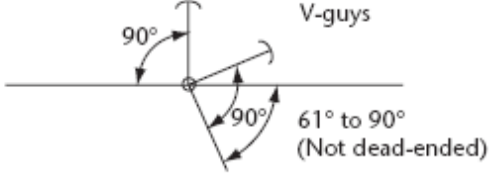
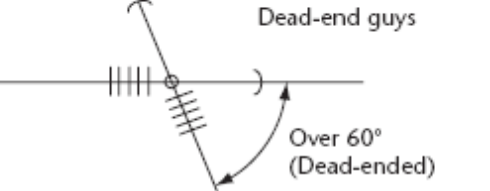
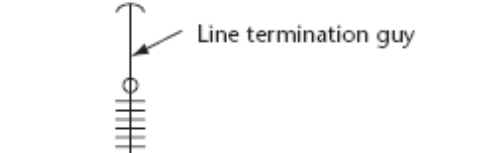
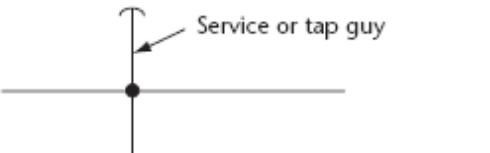
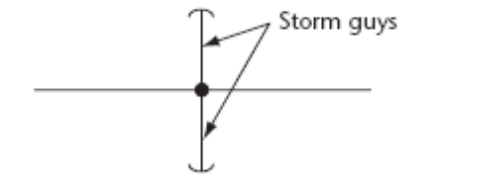
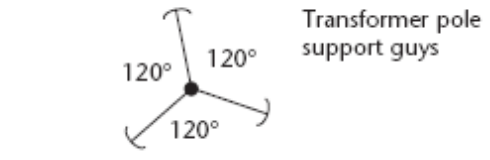
| | | |
|--|-------|--|
|  <p>Bisector guy</p> | No. 1 | <p>Line angles 4° to 60° Guy(s) shall be placed so that the angle is bisected as shown in sketch. This shall apply regardless of number of guys used.</p> |
|  <p>V-guys</p> | No. 2 | <p>Line angles 61° to 90° (conductors not dead-ended) Guys shall be placed at 90° to each line section as shown in sketch.</p> |
|  <p>Dead-end guys</p> | No. 3 | <p>Line angles over 60° (conductors dead-ended) Guys shall be placed in line as shown in sketch.</p> |
|  <p>Line termination guy</p> | No. 4 | <p>Line termination guying (conductors dead-ended) Guy(s) shall be placed as shown in sketch.</p> |
|  <p>Service or tap guy</p> | No. 5 | <p>Service or tap Guy(s) shall be placed as shown in sketch.</p> |
|  <p>Storm guys</p> | No. 6 | <p>Line angles 0° to 3° Storm guys shall be used where specified as shown in sketch.</p> |
|  <p>Transformer pole support guys</p> | No. 7 | <p>3 down guys 120° apart located below transformer. Guy location for transformer pole with no overhead distribution.</p> |

Note: These arrangements shall be permitted to be altered to suit local conditions.



For Your Safety

Specification 27
Attachment of guys "pole fitting" to primary circuits
[See Rule 75-256(1).]

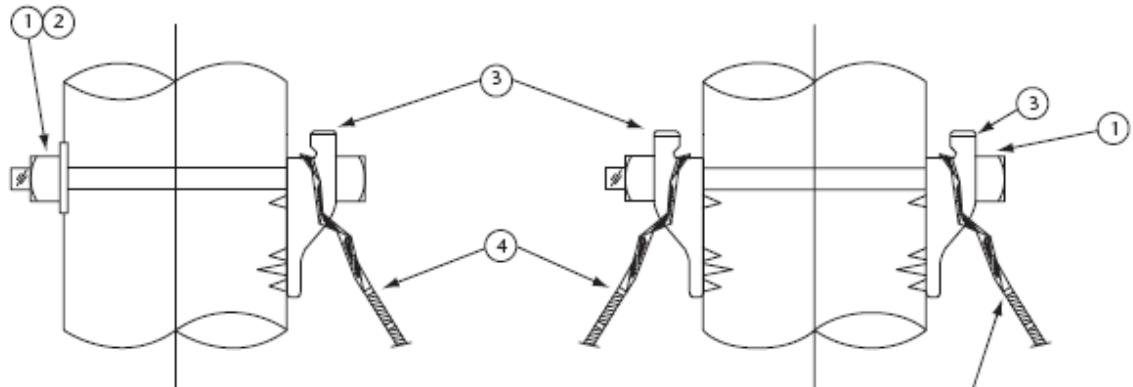

Figure 1
Single guy

Figure 2
Storm guy

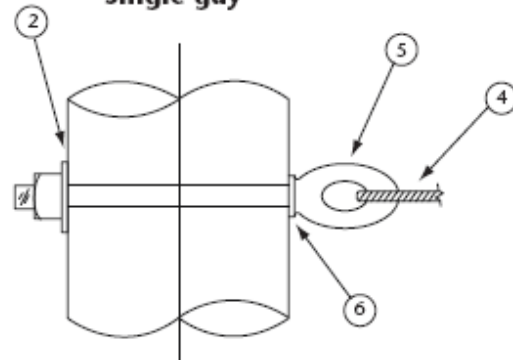

Figure 3
**Span and anchor guy
line pole**

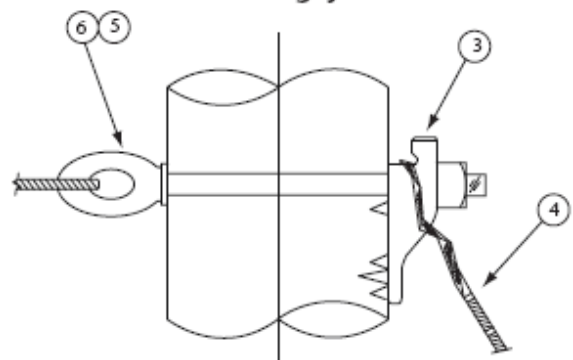

Figure 4
**Span and anchor guy
stub pole**

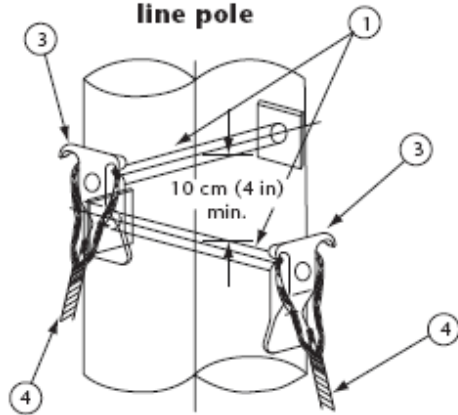

Figure 5
V-guy

Legend:

- 1 = Bolt, 3/4 in
- 2 = Washer, curved, galvanized
- 3 = Hook, guy, horn type
- 4 = Grip, guy wire 9 mm
- 5 = Bolt, eye, thimble, 3/4 in
- 6 = Washer, 2 x 2 x 3/4



For Your Safety

**Specification 28
Service mast installation**

[See Rules 75-324(2), 75-502, and 75-504.]

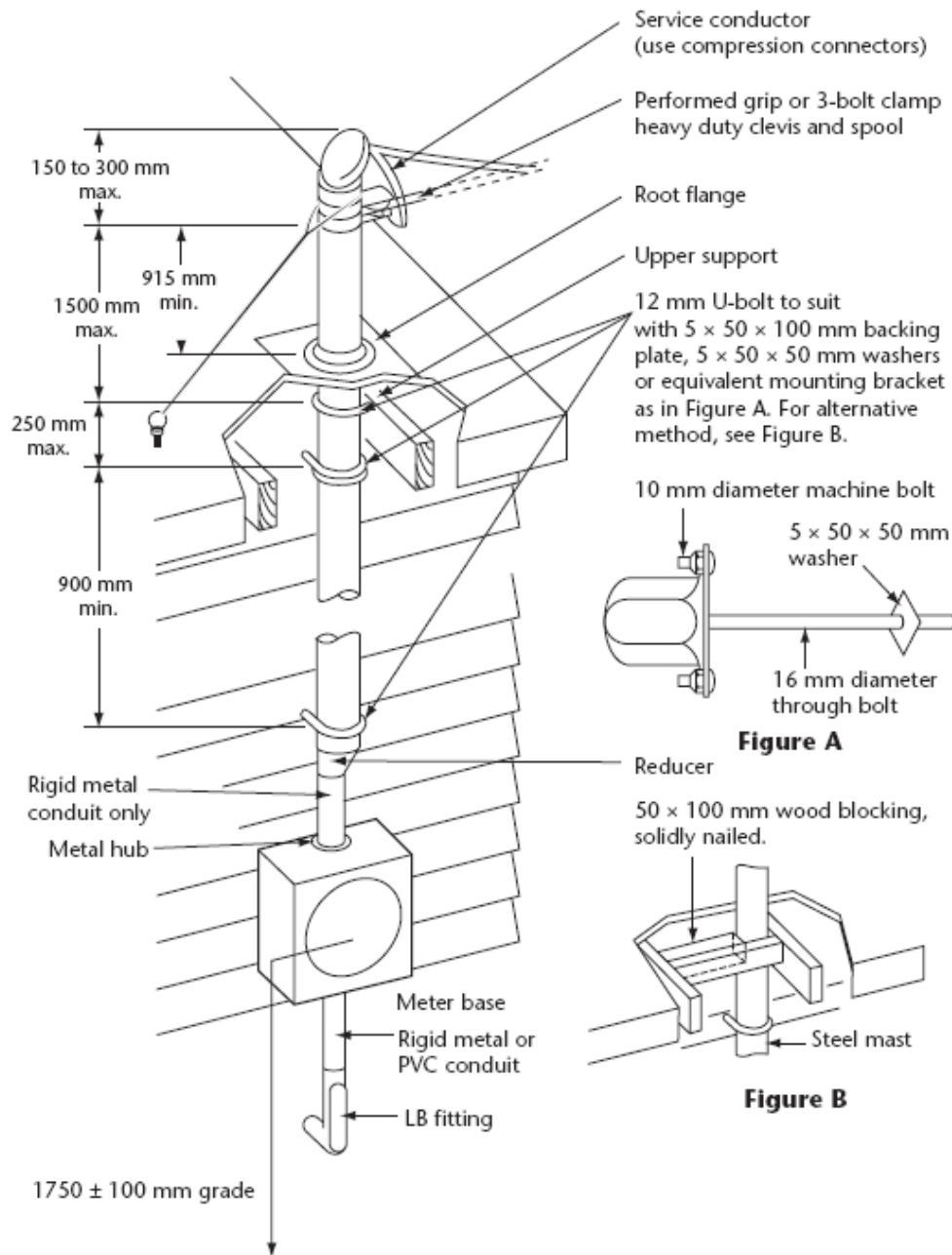

Notes:

- (1) All hardware shall be hot dipped, galvanized steel or corrosion resistant.
- (2) Where the maximum attachment height exceeds 1500 mm, guying shall be employed and connected to an eye bolt fastened to a building structural member.
- (3) Compression connectors shall be used where required.



For Your Safety

**Specification 29
Wood crossarm**

[See Rule 75-262(1).]

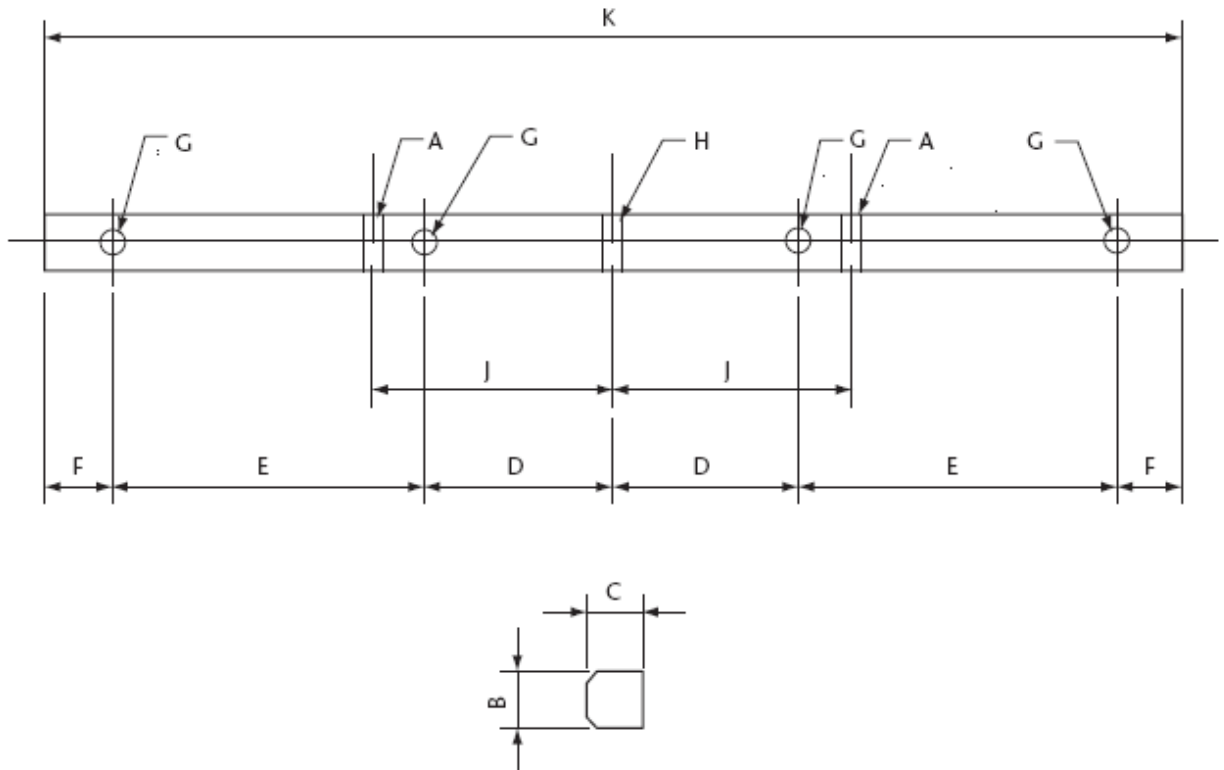

Dimensions

| K | B | C | D | E | F | G | H | J | A |
|--------------------------|------------------------|-------------------------|------------------------|--------------------------|------------------|-----------------------|-----------------------|-------------------------|--------------------|
| 2997 mm (9 ft, 10 in) | 95.25 mm (3-3/4 in) | 120.65 mm (4-3/4 in) | 457 mm (1 ft, 6 in) | 914.5 mm (3 ft, 0 in) | 127 mm (5 in) | 17.5 mm (11/16 in) | 20.6 mm (13/16 in) | 559 mm (1 ft, 10 in) | 9.5 mm (3/8 in) |
| 2540 mm (8 ft, 4 in) | 95.25 mm (3-3/4 in) | 120.65 mm (4-3/4 in) | 381 mm (1 ft, 3 in) | 762 mm (2 ft, 6 in) | 127 mm (5 in) | 17.5 mm (11/16 in) | 20.6 mm (13/16 in) | 508 mm (1 ft, 8 in) | 9.5 mm (3/8 in) |

Note: All holes shall be in the centre of the face in which they are bored.



For Your Safety

Specification 30

Steel crossarm

[See Rule 75-262(2).]

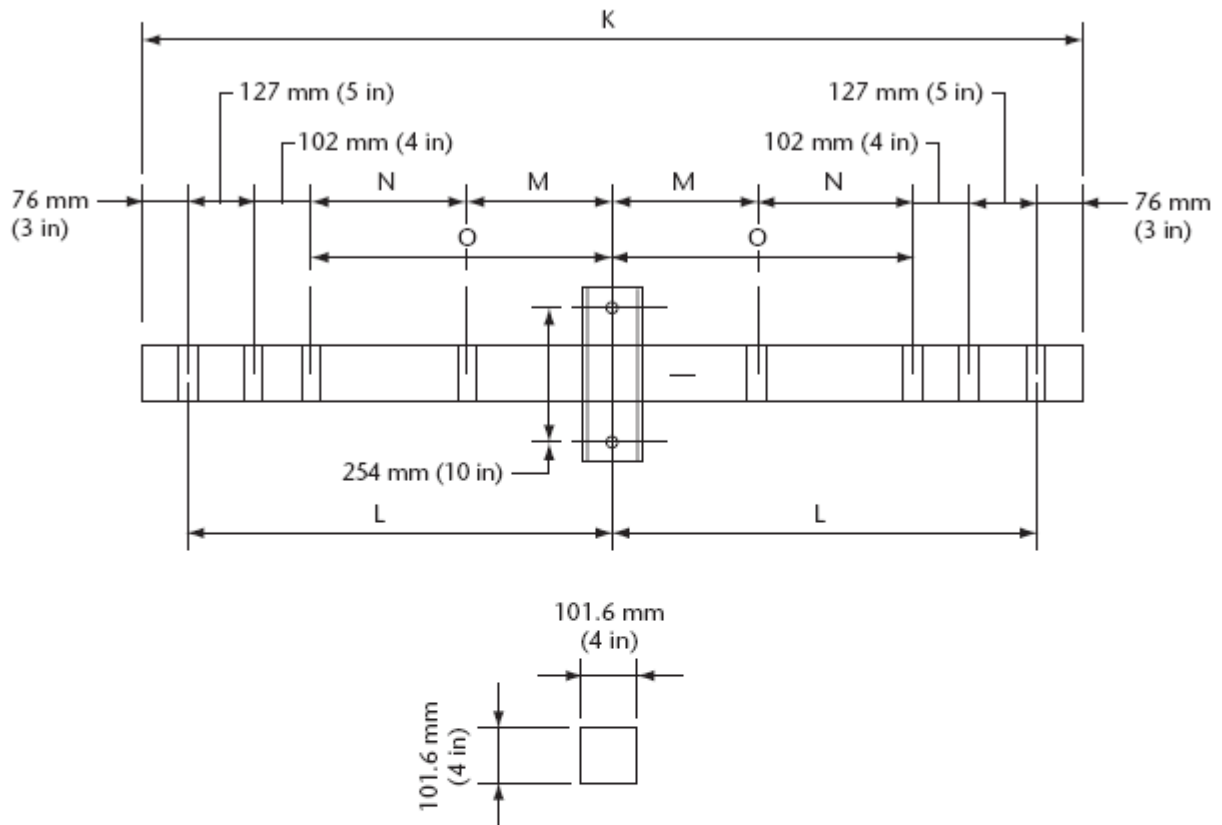

Hollow steel crossarms with welded steel end plates

| Dim. K | Dim. L | Dim. M | Dim. N | Dim. O | Total weight, kg (lbs) | Max. tension per conductor, kg (lbs) |
|-------------------------|--------------------|-------------------|-------------------|-------------------|------------------------------|--|
| 1676 mm (5 ft, 6 in) | 762 mm (30 in) | — | — | 533 mm (21 in) | 24 kg (53 lbs) | 1360 kg (3000 lbs) |
| 2286 mm (7 ft, 6 in) | 1067 mm (42 in) | 457 mm (18 in) | 381 mm (15 in) | — | 38 kg (84 lbs) | 1360 kg (3000 lbs) |
| 2896 mm (9 ft, 6 in) | 1372 mm (54 in) | 457 mm (18 in) | 686 mm (27 in) | — | 69 kg (152 lbs) | 1590 kg (3500 lbs) |

Note: All holes shall be 20.6 mm (13/16 in) diameter.

*Ground connector supplied with crossarm, conductor range No. 4 STR to No. 2/0 SOL.



For Your Safety

Specification 31
Pin-type insulators for crossarm framing
(See Rule 75-266.)

Primary
(Four-wire systems)
Line voltage, kV
2.4/4/16 to 4.8/8/32,
7.2/12.47, 8/13.8

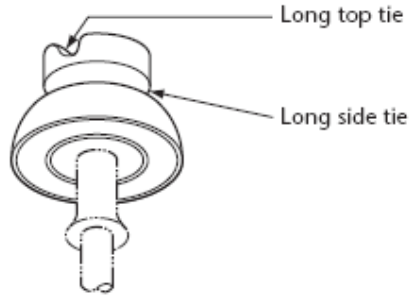

Primary
Line voltage, kV
14.4/24.9, 16/27.6

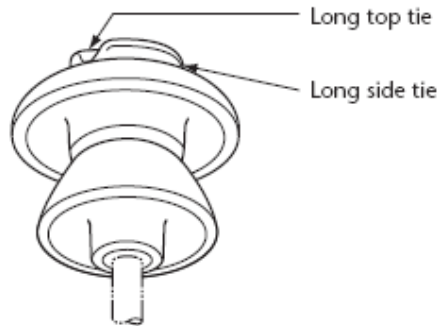

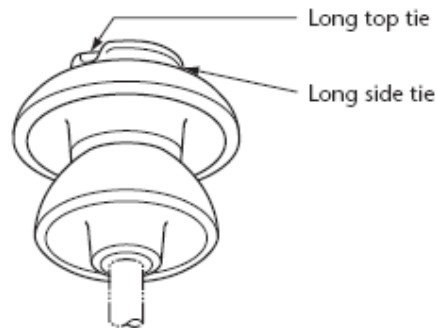

Subtransmission
(Three-wire systems)
Line voltage, kV
27.6 (including 13.8) 44



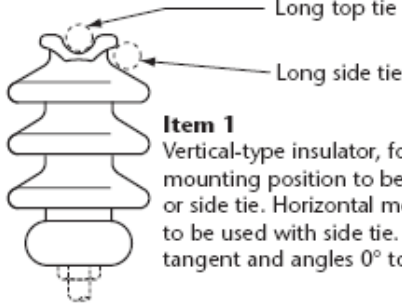

For Your Safety

Specification 32
Post-type insulators for armless framing
(See Rule 75-266.)

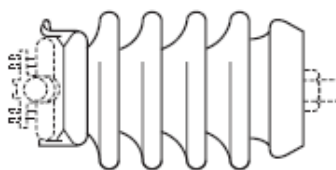
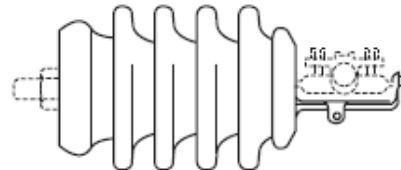
| | |
|---|---|
| <p>Primary (Four-wire systems) Line voltage, kV 2.4/4.16 to 4.8/8.32 7.2/12.47 8/13.8 14.4/24.9 16/27.6</p> <p>Subtransmission (Three-wire systems) Line voltage, kV 27.6 (including 13.8) 44</p> | <p>Tie top — vertical and horizontal</p>  <p>Item 1 Vertical-type insulator, for vertical mounting position to be used with top or side tie. Horizontal mounting position to be used with side tie. Suitable for tangent and angles 0° to 15°.</p> |
| | <p>Clamp top — vertical or horizontal</p>  <p>Item 2a Vertical-type clamp top insulator in vertical mounting position for tangent and angles 0° to 15°.</p>  <p>Item 2b Vertical-type clamp top insulator in horizontal mounting position for angles 16° to 45°.</p> |
| | <p>Clamp top — horizontal</p>  <p>Item 3 Horizontal-type clamp top insulator in horizontal mounting position for tangent and angles 0° to 15°.</p> |

For Your Safety

**Specification 33
Suspension-type insulators**

(See Rule 75-266.)

Suspension-type insulators

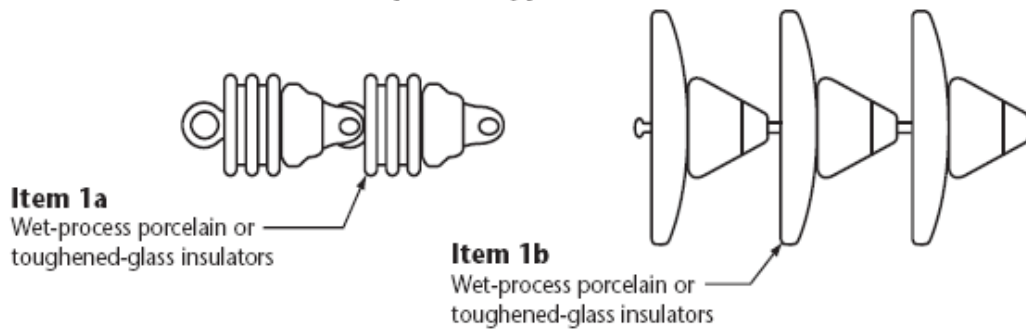

Application of porcelain or glass suspension-type insulators — Number required

| System | Angles, switches and deadends | | In-span live-line openers | Floating dead-ends |
|---|-------------------------------|---------------------------|---------------------------|-----------------------|
| | Wood | Steel | | |
| Primary (4-wire) up to 8/13.8 kV | Item 1a 2 required | Item 1a 3 required | Item 1a 4 required | Item 1a 4 required |
| 14.4 /24.9 kV and 16/27.6 kV | Item 1a or 1b; 3 required | Item 1a or 1b; 4 required | Item 1b 4 required | Item 1a 6 required |
| Subtransmission (3-wire) 27.6 and 44 kV | Item 1b 4 required | Item 1b 4 required | Item 1b 4 required | N/A |

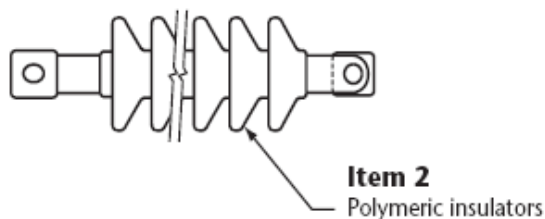

Application of polymeric suspension-type insulators (Item 2)

| System voltage | Marking |
|----------------|---------|
| 15 kV | DS 15 |
| 27.6 kV | DS 28 |
| 44 kV | DS 46 |



For Your Safety

**Specification 34
Grounding for overhead installations on wood pole**

[See Rule 75-404, 75-410(3), and 75-504(4).]

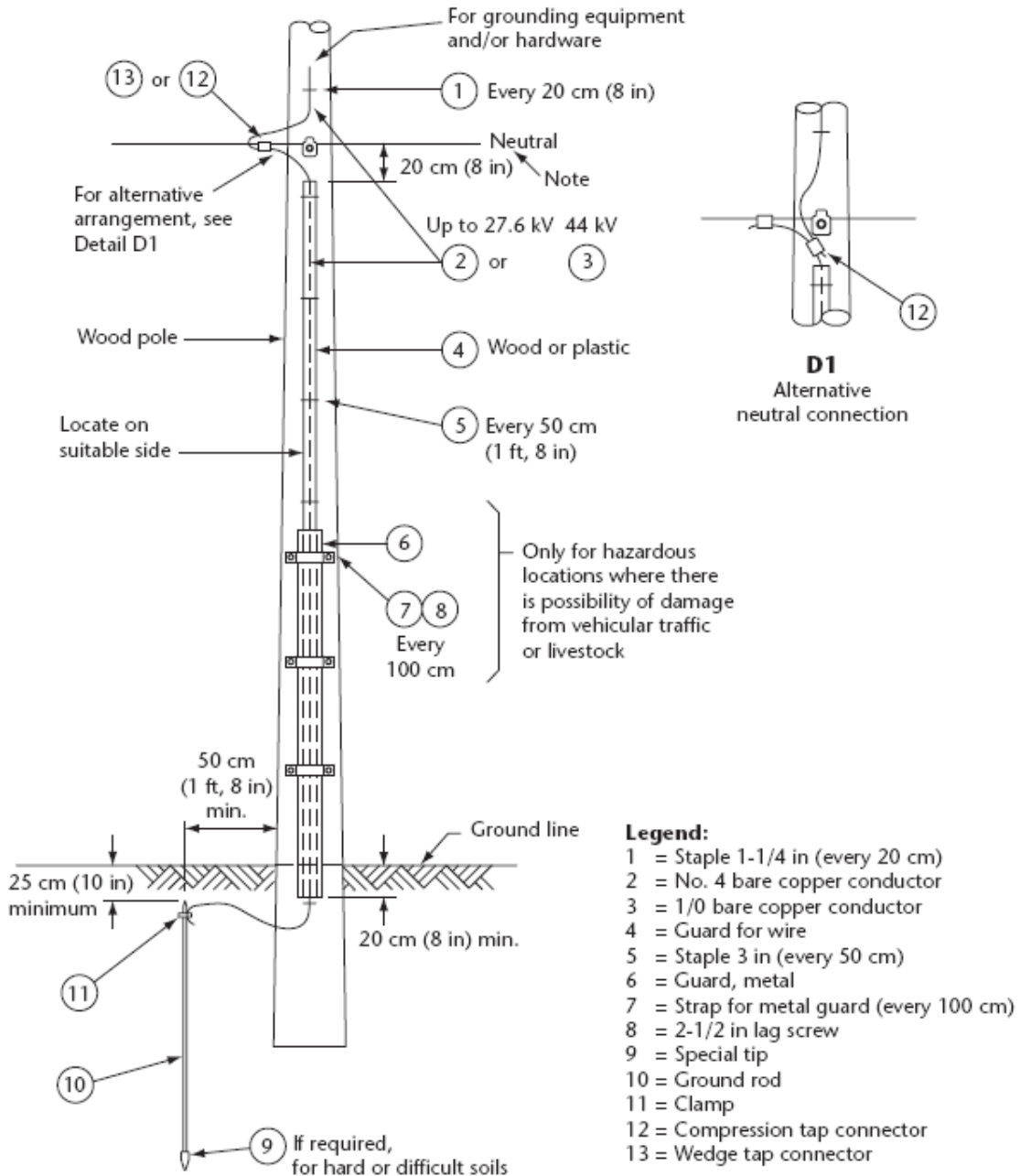

Note: For installations without a neutral, continue the ground wire and moulding up near the level of the first grounding connection of the equipment or hardware.



For Your Safety

**Specification 35
Details of secondary service rack or neutral spool**

[See Rule 75-324(1).]

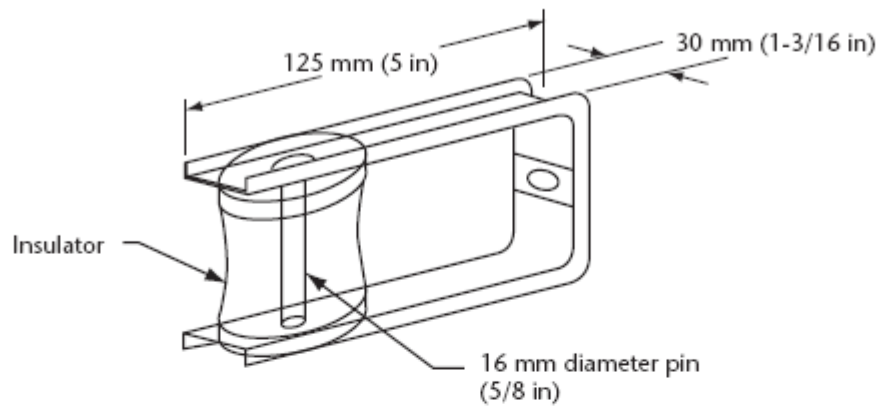

**Figure 1
One-wire rack
(Neutral spool)**

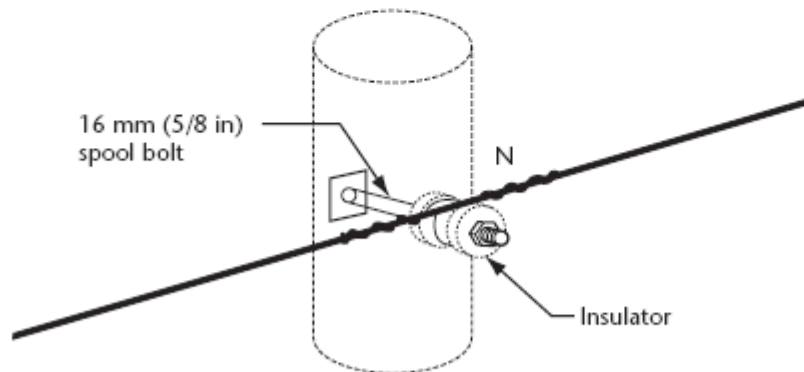

**Figure 2
Neutral spool
Tangent (0° to 3°)**

For Your Safety

Specification 36
Secondary: Attaching service tap to an intermediate pole for support
[See Rule 75-324(1).]

Figure 1
For 0° to 15° angles

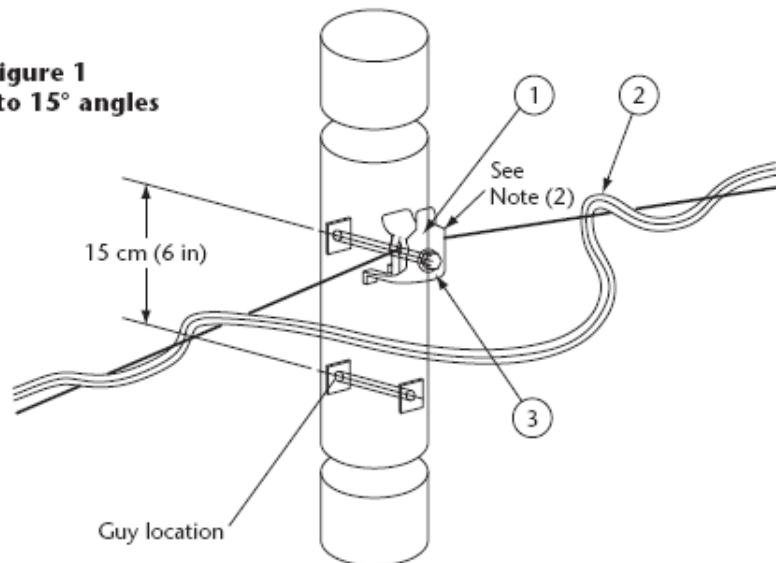
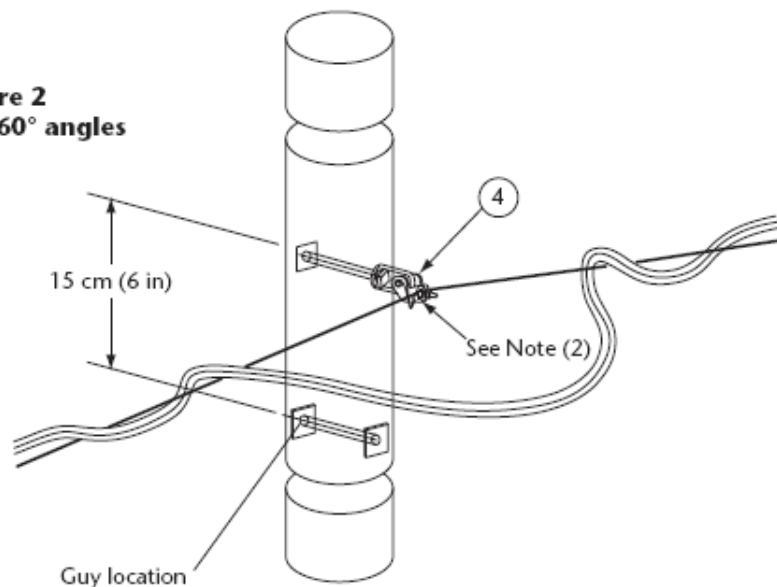

Figure 2
For 16° to 60° angles



Legend:

- 1 = Neutral clamp
- 2 = Service tap
- 3 = Bolt, 5/8 in
- 4 = Corner clamp for conductors

Notes:

- (1) All bare connections shall be taped except neutral.
- (2) Secondary one-wire rack shall be permitted to be used. See Specification 35, Figure 1.



For Your Safety

Specification 37
**Secondary: Attaching service tap to an intermediate
pole for splitting into 2 or more services**
[See Rule 75-324(1).]

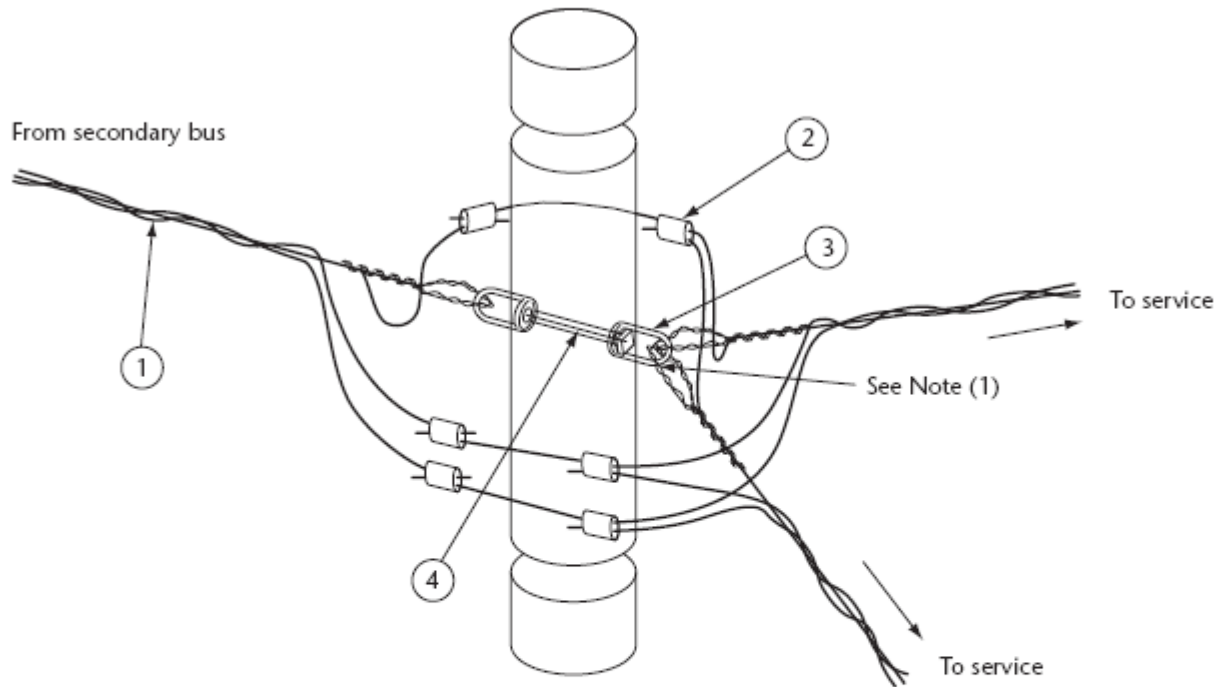

Legend:

- 1 = Service tap
- 2 = Tap connector with cover
- 3 = Eye for 5/8 in bolt
- 4 = Bolt, 5/8 in

Notes:

- (1) Secondary one-wire rack shall be permitted to be used. See Specification 35, Figure 1.
- (2) All bare connections shall be taped except neutral.
- (3) Compression connectors shall be used where required by Rule 75-322.



For Your Safety

Specification 38
**Secondary: Connecting pre-assembled single-phase
service below transformer**
[See Rule 75-324(1).]

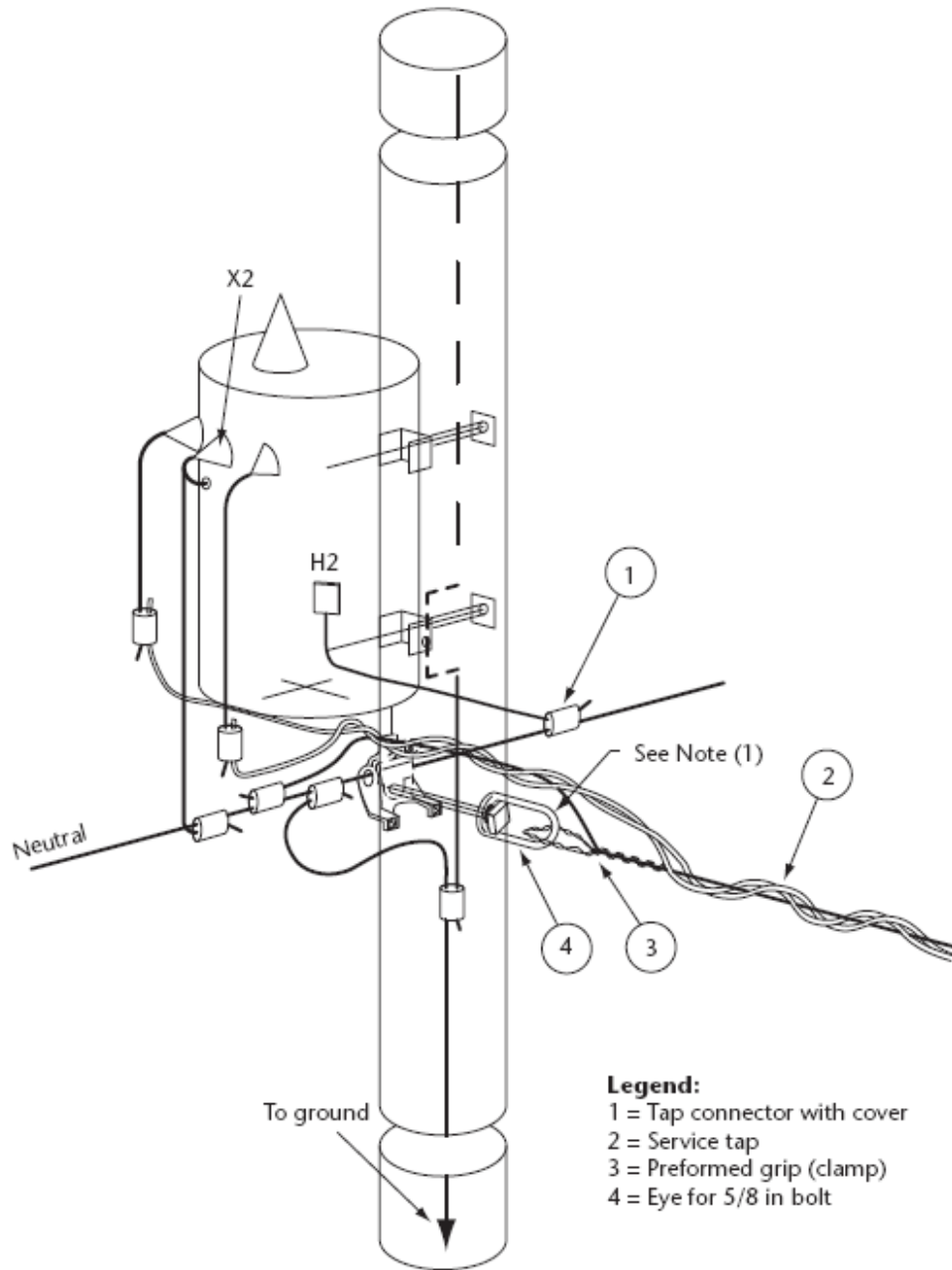

Note: Secondary one-wire rack shall be permitted to be used. See Specification 35, Figure 1.



For Your Safety

Specification 39
Secondary dead end
[See Rules 75-248(2) and 75-324(1).]

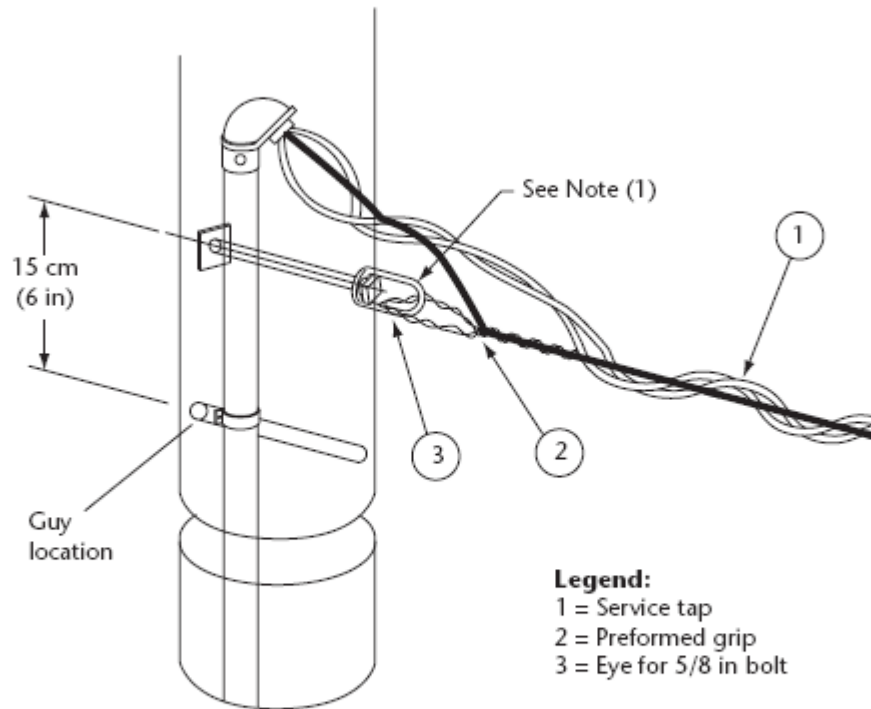

Note: Secondary one-wire rack shall be permitted to be used. See Specification 35, Figure 1.



For Your Safety

Specification 40
Metering: 2.4 to 16 kV single-phase grounded primary
[See Rule 75-504.]

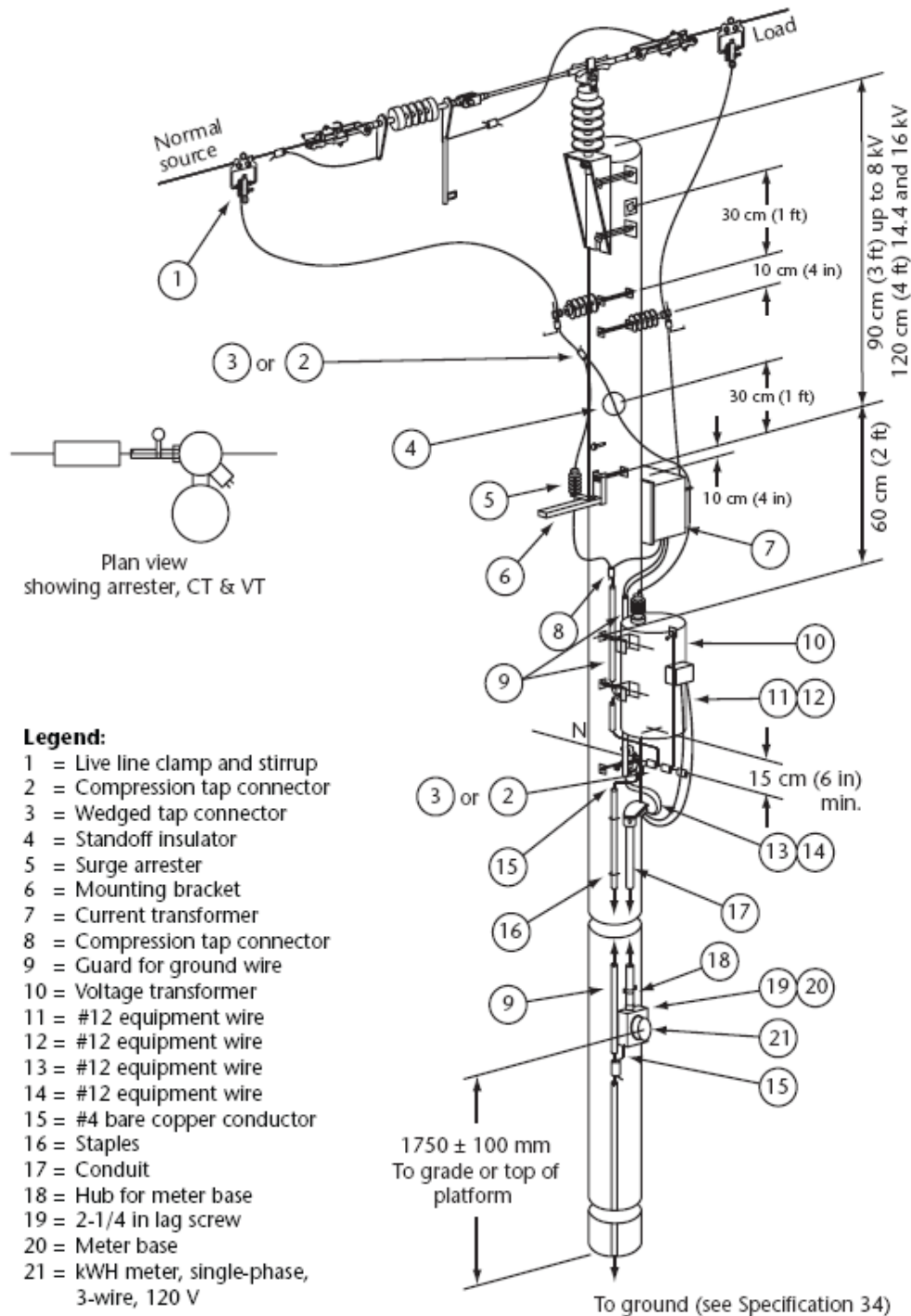



For Your Safety

Specification 41
Metering: Central metering for secondary drop-leads 4/0 and smaller
[See Rules 75-504(4).]

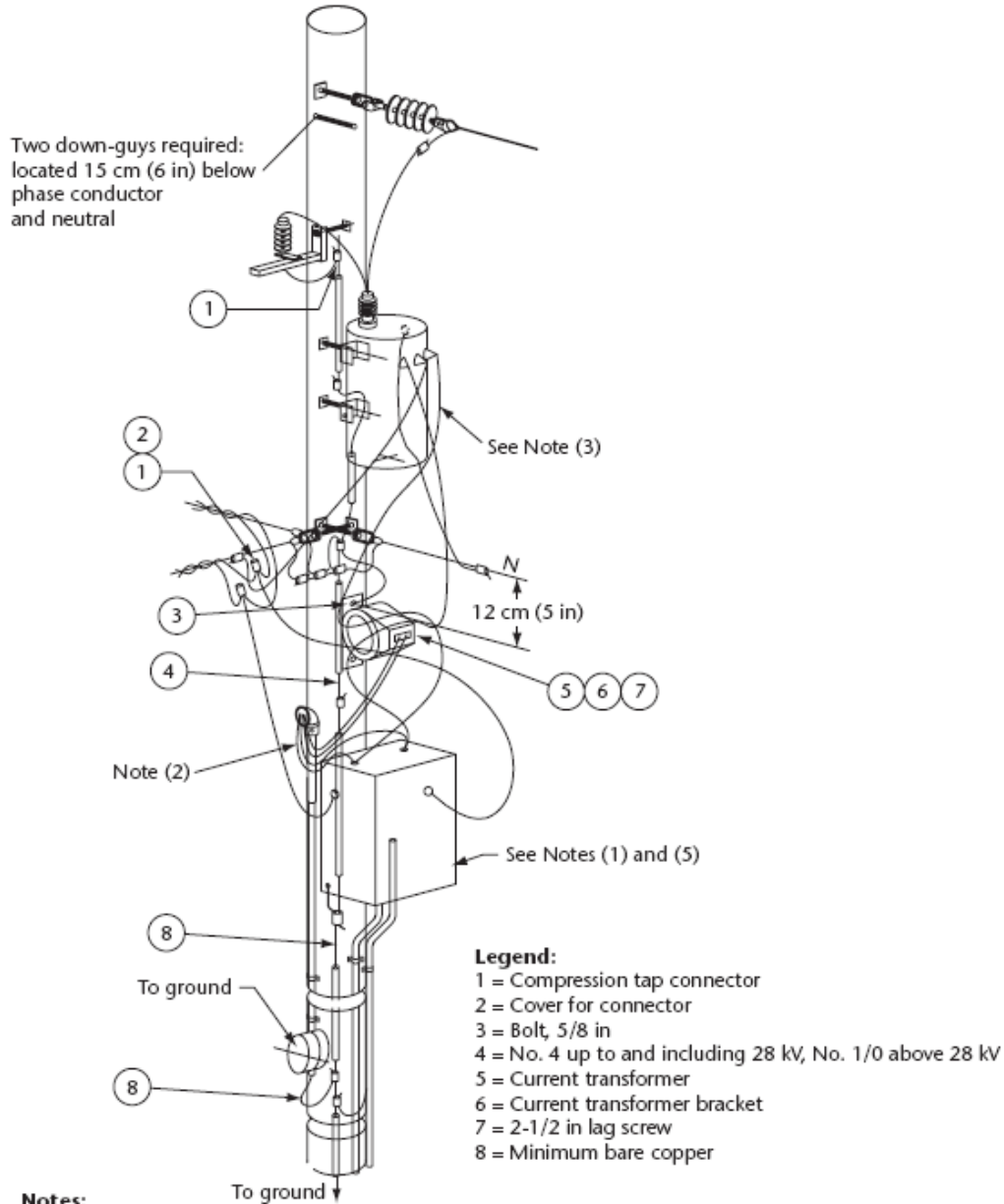

- Notes:**
- (1) Standby generator shall only be connected to wiring system through a double-throw switch that will prevent feedback on the supply authority's system.
 - (2) Leads at the weather cap must be minimum No. 12 copper only. Colour coding and number of conductors shall be as required by the supply authority.
 - (3) Drop-leads shall be copper only.
 - (4) Switch location is typical only.
 - (5) CTs should be installed such that the CT ratio can be seen from the ground.



For Your Safety

Specification 42

Metering: Central metering for secondary drop-leads larger than 4/0

[See Rule 75-504(4).]

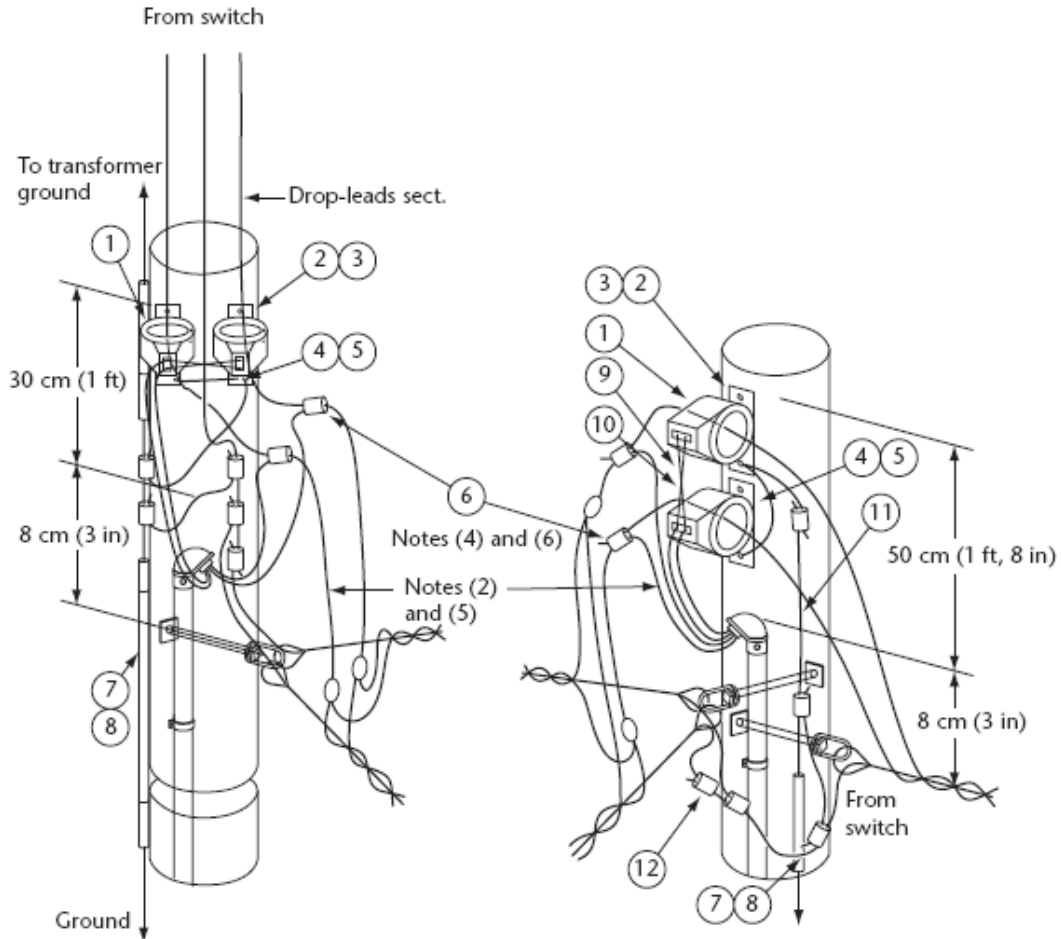

**Figure 1
Transformer pole**

**Figure 2
Intermediate pole**

Legend:

- | | |
|-----------------------------|----------------------------------|
| 1 = Current transformer | 7 = Guard for ground wire |
| 2 = Bracket for transformer | 8 = Staples |
| 3 = 2-1/2 in lag screw | 9 = No. 12 equipment wire |
| 4 = Bolt, 5/8 in | 10 = No. 12 equipment wire |
| 5 = Ground splice connector | 11 = No. 4 bare copper conductor |
| 6 = Bolted tap connector | 12 = Compression tap connector |

Notes:

- (1) This arrangement is for conductors larger than No. 4/0.
- (2) Maximum voltage 1-phase, 3 W, 120/240 V service.
- (3) The potential lead shall be doubled up to obtain adequate fill of the connector groove. Insulation shall not be removed from either lead.
- (4) Leads at the weather cap shall have drip loops.
- (5) Drip loops shall be provided at all insulated conductor connections.
- (6) CTs should be installed such that the CT ratio can be seen from the ground.



For Your Safety

**Specification 43
Metering for 3-phase, 120/208 V, 4-wire system**

[See Rules 75-504(4).]

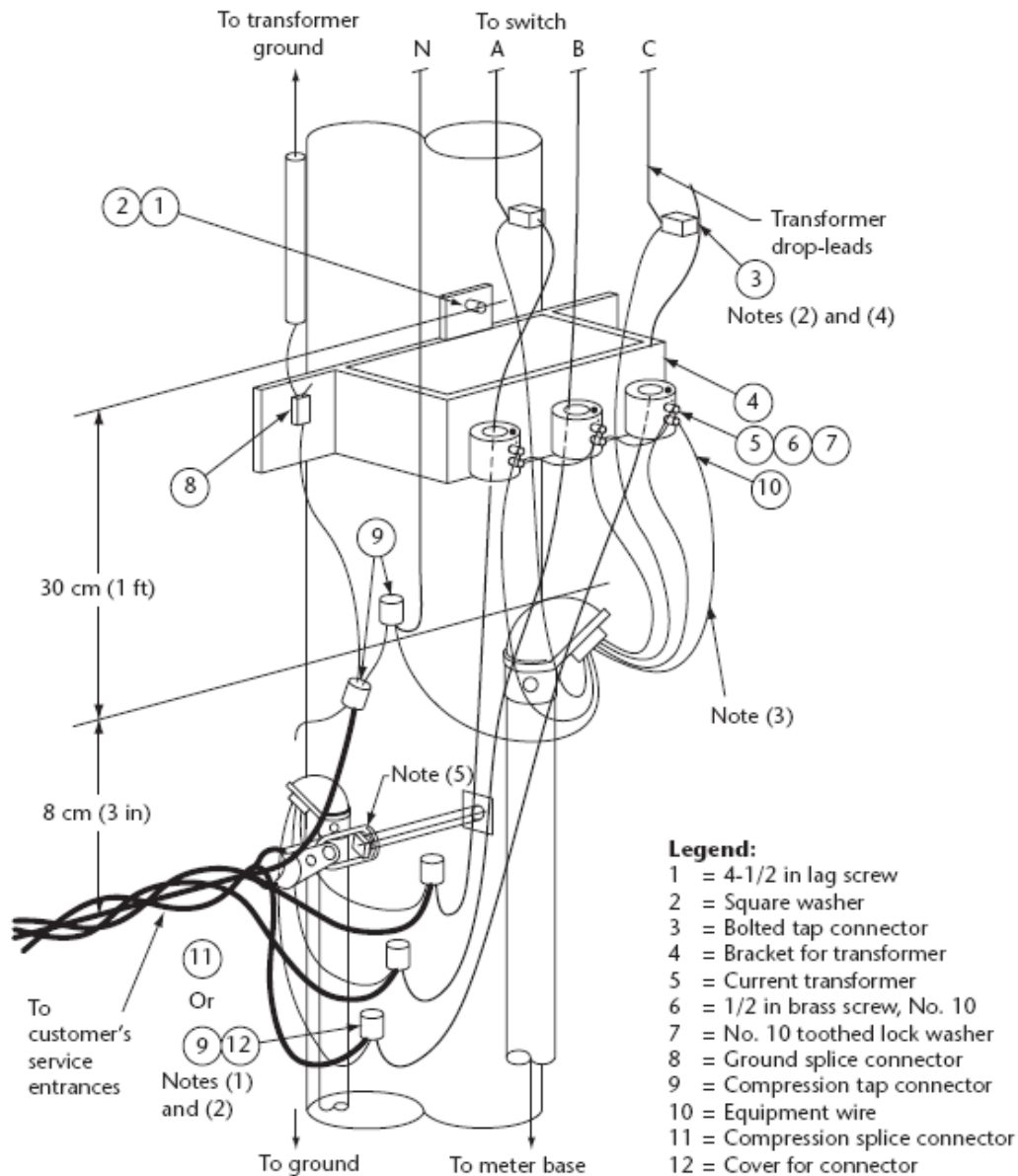

Notes:

- (1) Underground service shall be permitted to replace overhead. If required, either service shall be permitted to connect to copper drop leads.
- (2) Drip loops shall be provided at all insulated conductor connections.
- (3) All metering leads shall be bundled to provide mechanical rigidity.
- (4) Potential lead shall be doubled up to obtain adequate fill of the connector groove. Insulation shall not be removed from either lead.
- (5) One-wire rack shall be permitted to be used. See Specification 35, Figure 1.



For Your Safety

Specification 44
Grounding connection to steel pole, single-phase transformer
(See Rule 75-212.)

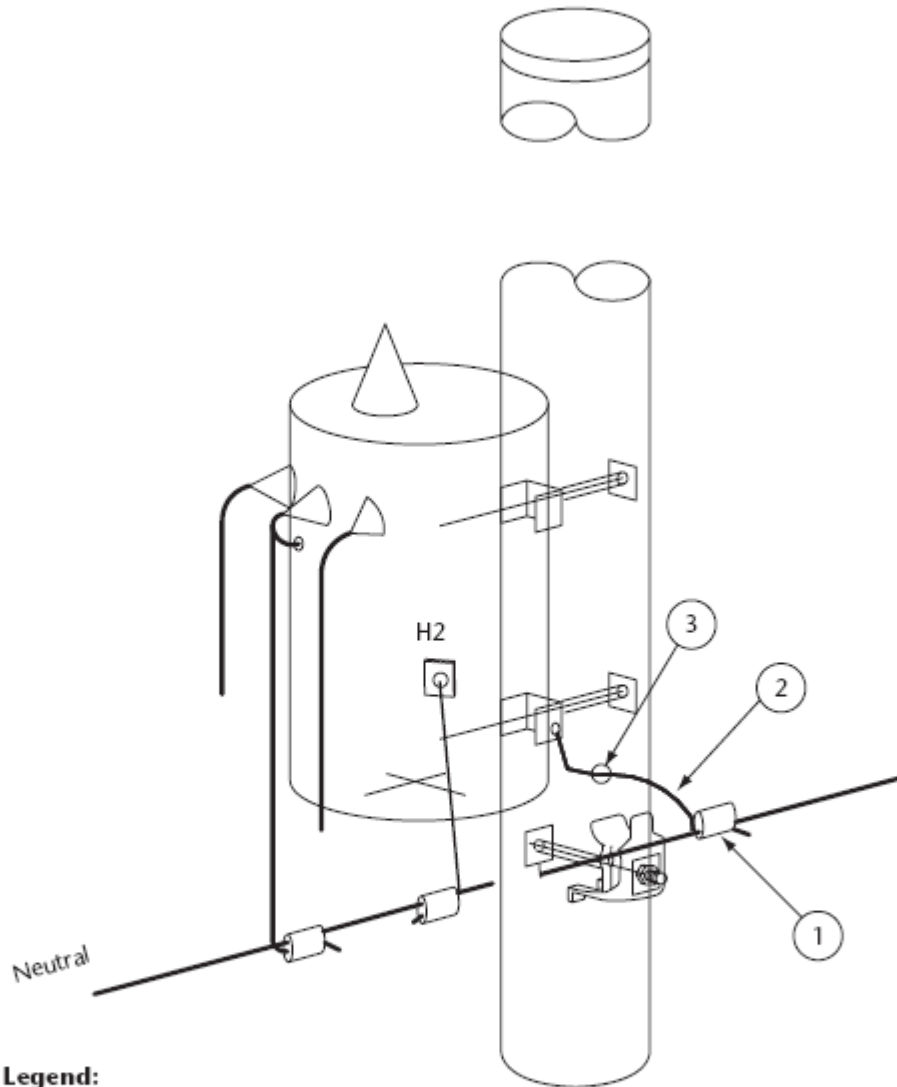

Legend:

- 1 = Connector, conductor, wedge
- 2 = Conductor, bare, copper No. 4
- 3 = Connector, ground, bolted

Note: Secondary one-wire rack shall be permitted to be used. See Specification 35, Figure 2.



For Your Safety

Specification 45
Grounding connection to steel pole, three-phase transformer
(See Rule 75-212.)

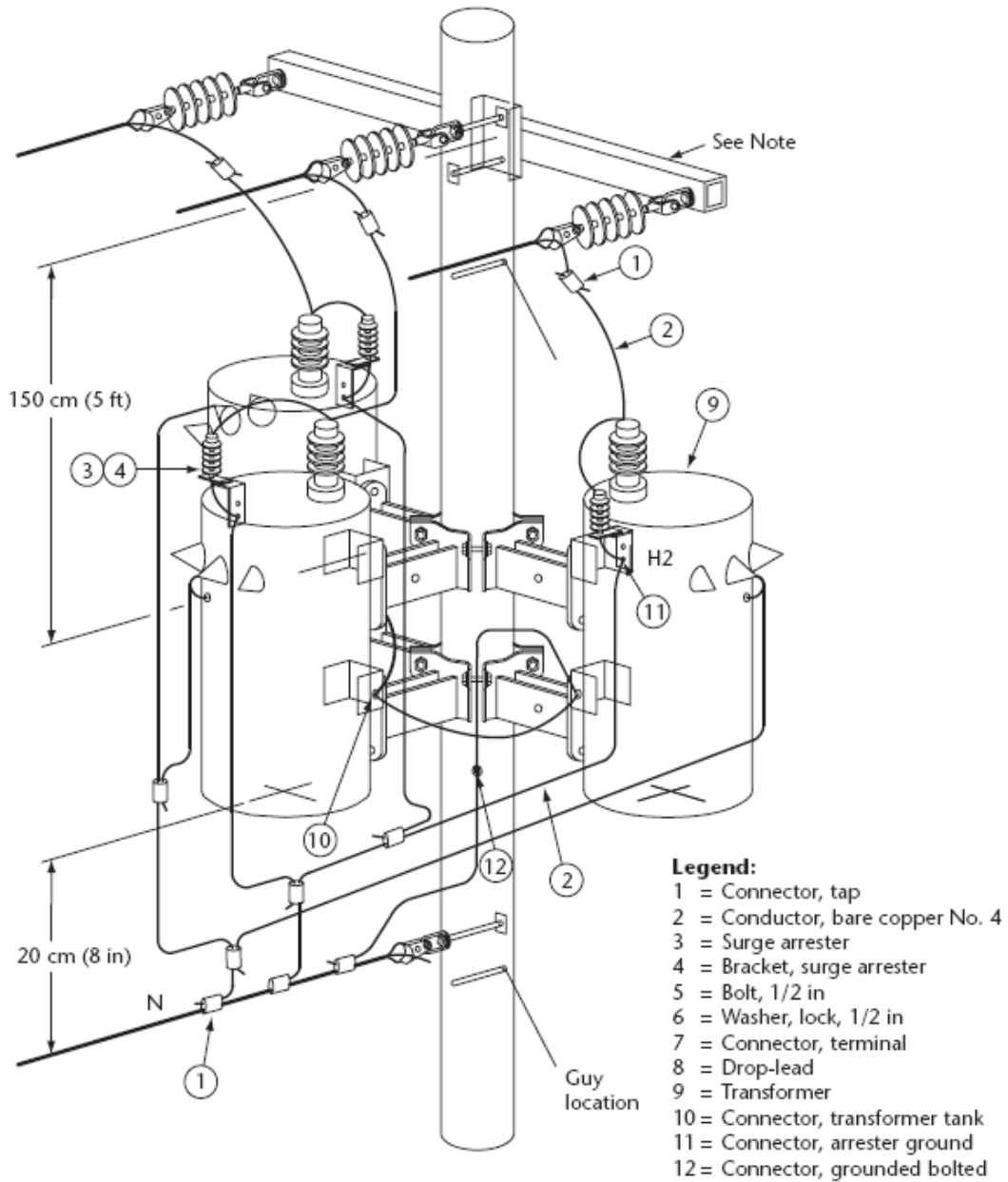

Note: Rule 75-402 requires steel crossarms to be connected to a ground electrode where porcelain dead-end insulators are used with a copper conductor.