

FRONT BACK LABELER WITH WRAP STATION - CVC 430



The CVC 430 Front & Back Labeler with Wrap Station is a dual-purpose machine built to automatically apply pressure sensitive labels onto the front and/or back of containers and has a separate station for wrapping labels onto round containers. It can also be ordered with an optional assembly for applying a label to 3, 4, or 5 panels of a square or rectangular container. 3 Applications in 1 Machine! The 430 can be ordered with one or two labeling heads and is an ideal machine for contract packagers and manufacturers serving the food, nutraceutical, pharmaceutical, gas, oil, and personal care markets.

STANDARD FEATURES

- Self-Set Auto Adjusting Control System
- Stainless Steel Frame on lockable casters
- Stainless Steel flatbed conveyor with table top chain
- Touchscreen HMI
- Label head with up to $\pm 1/32$ " accuracy (*bottle dependent)
- Removeable Wrap Station
- Label Sensor for Paper or Opaque Labels
- Product Sensor with Opaque and Clear Bottle Mode
- Variable Speed Separator Wheel



All CVC labelers include our patented Self Set™ software which utilizes a high frequency encoder for extremely easy setup and wrinkle free labeling at the touch of a button.

CVC 430 Technical Specifications

Speed	Up to 175 Bottles per Minute (BPM)
Bottle Height	Configurable from 2" to 16" (51mm – 406mm)
Bottle Diameter	Configurable from 1/2" to 6 1/4" (13mm – 159mm)
Label Width / Height	Configurable from 1/4" to 9" (16mm – 229mm)
Label Length	1/4" to 12" (16mm – 305mm)
Label Roll	Max 14" (356mm) outside diameter with 3" core
Dispense Speed	Max 23 meters / min.
Conveyor Width	Configurable up to 6"
Conveyor Length	Standard 95 1/2" (Extendable)
Conveyor Bed Height	Standard 36" (+/- 2")
Power	110V, Single Phase, 5 Amp (220V optional)
Air Pressure	Minimum 85 psi (ISO 8573-1)
Air Consumption	4 cfm (for optional reject and Lot/Date printer)
Machine Weight	324 kg

TECHNICAL SPECIFICATIONS

AVAILABLE OPTIONS

- Hot Stamp (Lot/Date Coding)
- Integrated Thermal Encoder (Lot/Date, Bar Code and Graphics)
- Adjustable Tilt for Tapered Bottles
- Clear Label Sensor
- Feed Screw
- Infeed and Outfeed Conveyor Extensions
- Low Label (Factory Installed Only)
- Push and Press
- Raised Sanitary Bed conveyor (Factory installed only)



THERMAL TRANSFER PRINTER



VISION INSPECTION SYSTEMS

MACHINE LAYOUTS

Top View

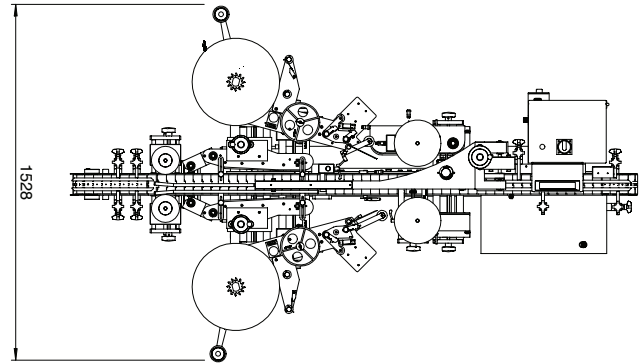

Front View

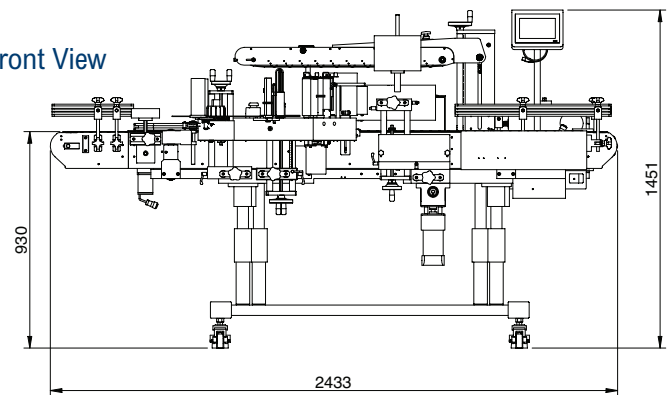

The dimensions shown are for standard machine. The conveyor can be extended: the length may vary based on selected options. This machine can run independently or be integrated into an automated packaging line. All CVC equipment is covered by a one-year parts warranty. Full Warranty details are included in our equipment proposals or can be found on our website.



CVC Technologies, Inc.

10861 Business Drive, Fontana, CA 92337, USA

Phone: +1 (909) 355-0311 Fax: +1 (909) 355-0411

<http://www.cvctechnologies.com>

E-mail: sales@cvcusa.com

CVC USA East Coast Office

1855 New Highway, Suite C, Farmingdale NY 11735

E-mail: sales@cvcusa.com