

# TRAILERS



  
**TRAILERS OF ST. LOUIS**  
*Trailers & Truck Beds*

# TABLE OF CONTENTS



<b>Iron Clad Warranty and Roadside Assistance</b> .....	3
<b>Dump Trailers</b>	
DTB Model 7k-21k Dual 6" I-Beam Bumper Dump Trailer .....	4-5
DWB Model 14k 8" I-Beam Frame Dump Trailer .....	6-7
DTG Model 14k-21k Gooseneck Dump Trailer .....	8-9
DDP Model 14k-21k 96" Wide Deckover Bumper Pull Trailer .....	10-11
DDG Model 14k-21k 96" Wide Deckover Gooseneck Dump Trailer .....	12-13
DSG Model 12k 102" Wide Tandem Dual Demolition Dump .....	14-15
DMG Model 22k 102" Wide Tandem Dual Dump .....	16-17
DBG Model 14k Gooseneck Roll Off Dump Trailer .....	18-19
<b>Equipment Trailers</b>	
ETB Model 10k-21k 6" Channel Equipment Bumper Pull Trailer .....	20-21
EWB Model 14k 8" I-Beam Equipment Bumper Pull Trailer .....	22-23
ETG Model 14k-22k Channel Equipment Gooseneck Trailer .....	24-25
<b>HD Deckover Gooseneck and Pintle Trailers</b>	
FDG14 Model 14k 10" I-Beam Deckover Gooseneck .....	26-27
FDP14 Model 14k 10" I-Beam Pintle Equipment Trailer .....	28-29
FTG14 Model 14k 12" I-Beam Deckover Gooseneck .....	30-31
FHG22 Model 22k Gooseneck Low-Pro Hydraulic Dove Trailer .....	32-33
FLG22 Model 22k Gooseneck Low-Pro Equipment Trailer .....	34-35
FLP22 Model 22k Deckover Pintle Trailer .....	36-37
FLP50 Model Super HD Pintle Trailer .....	38-39
<b>Tilt Trailers</b>	
TLB14 Model 10k-21k Low-Pro Bumper Pull Tilt Trailers .....	40-41
TDP14 Model 14k Deckover Tilt Pintle Trailer .....	42-43
<b>Utility Trailers</b>	
UTB Model 7k Utility Trailers .....	44-45
<b>Accessories</b>	
Trailer Parts Side Extensions, Jacks, Cold-Weather Wiring, Hydraulics, Add-Ons, Toolboxes, Tires .....	46-47
<b>Social Media References and Links</b>	
QR Codes Find Us On Social Media .....	48-51

The North American Trailer Dealers Association is a professional business association in North America that serves the light and medium duty trailer dealers and brings them together as a unified team. For years, the trailer industry has struggled hard and waited patiently to gain financial strength, professional credibility and industry recognition. Now, the wait is finally over! By uniting the trailer dealers within a professional business association, NATDA is able to provide dealers with only the very best benefits, programs and education available.

The NATM Compliance Verification Program (CVP) is a mandatory program for all NATM member trailer manufacturers. This program involves multiple components, all of which are geared toward creating safer trailers and in turn, safer roadways.

All NATM trailer manufacturer members are required to successfully complete a compliance consultation. Once a member has done so, they are able to purchase and place NATM Compliance Decals on their trailers.







**BEST IN CLASS TRAILER** ✓  
**BEST IN CLASS WARRANTY** ✓  
**FREE ROADSIDE ASSISTANCE** ✓

*Let's Roll*

**Roadside: 888-399-0327**

Iron Bull trailers are some of the best in the market, and we are happy to provide our industry-best IronClad Warranty to back them up. Our manufacturer's warranty program covers structure and components, and even adds free 24-hour roadside assistance to every trailer standard. No service contracts, no hoops to jump through, and no hassles, just take your Iron Bull Trailer to any authorized dealer for fast and friendly service.

**3 YEAR**

**Structural Coverage**

Your Iron Bull trailer is warranted to be free from structural defects for a period three years from the date of purchase.

**2 YEAR**

**Component Coverage**

This protection warrants every component (non-structural items) on your Iron Bull trailer to be free from defects for a period of two years from the date of purchase.

**2 YEAR**

**Free Roadside Assistance**

Each Iron Bull trailer is covered by a nationwide 24/7 roadside assistance program with benefits extending to the tow vehicle.

### Roadside Assistance Details:

Each Iron Bull trailer is covered for a period of two years from the date of purchase with a free roadside assistance package. Benefits include:

- Flat Tire Changes
- Towing and Road Service (tow vehicle and trailer)
- Jump Starting
- Fluid Delivery (including fuel, hydraulic & coolant)
- Lock Out Service
- On the road and off road coverage
- Consumer and commercial coverage
- All benefits extend to the tow vehicle
- Included free on every Iron Bull Trailer

### The program is simple to use:

- 1) Register your new Iron Bull trailer online at [www.norstarwarranty.com](http://www.norstarwarranty.com)
- 2) Have VIN no. and Plan Identifier available (found on trailer).
- 3) Call our toll-free 24/7 dispatch line at **888-399-0327**. A service provider will assist in locating service provider.

**Roadside: 888-399-0327**

For full warranty details please refer to your owner's manual or visit [www.norstarwarranty.com](http://www.norstarwarranty.com).



# DTB MODEL



## Dual 6" I-Beam Dump Trailer



### 2023 DTB

Iron Bull DTB model trailers are built to work. With 9,900 - 21,000 lbs of GVWR, tons of lifting power and dual 6" I-beam with 24lbs per foot. The DTB gives you strength where strength really matters.



#### BOX CAPACITY (CUBIC YARDS)

SIZE	BASE	3FT	4FT
5x10	2.8		
6x10	4.4	6.7	8.9
72x12	5.3	8.0	10.7
83x12	6.1	9.2	12.3
83x14	7.2	10.8	14.3
83x16	8.2	12.3	16.4

## STANDARD FEATURES

- Dual 6" I-Beam Frame (12lbs/ft)
- 7 Gauge Steel Flooring
- 4" Tubing Bed Frame
- 3 x 3/16" Channel Crossmembers
- Full Length Bed Runners and Ramp Pockets
- 10 Gauge 18" or 24" Steel Sides
- Standard Retractable Tarp Kit
- 10k Drop-Leg Jack
- 2 5/16" Adjustable Coupler
- Cambered Brake Axles
- Multi-leaf Slipper Spring Suspension
- Black Mod Wheels
- Radial Tires
- Spare Tire Mount
- Slide-in Ramps

- Rear Support Stand Bracket
- Three-Way Spreader Gate
- Powdura Powder Coat & One Cure Primer
- Scissor Hoist with 516 Cylinder
- Double Acting Pump Unit w/ Gravity Down Flow Control Valve
- Locking Pump Box
- Standard Stake Pockets
- Weld On Diamond Plate Fenders
- Four Floor Mounted 5/8" D-Rings
- DOT Approved Lifetime LED Lighting
- Molded Sealed Harness with Resistors
- LED Voltage Indicator in Remote
- Built-In 5 amp Battery Charger
- 7-Way Receiver Female Plug with Adapter



## 2023 BASE SPECS

WIDTH	LENGTH	GVWR	AXLES	TIRE/WHEEL	SIDES	WEIGHT
60	10	7000	2 X 3500 lb	205/75R15 5 Hole	18"	2630
60	10	10000	2 X 5200 lb	225/75R16 6 Hole	18"	2730
72	10	10000	2 X 5200 lb	225/75R16 6 Hole	24"	3640
72	12	10000	2 X 5200 lb	225/75R16 6 Hole	24"	3920
72	12	14000	2 X 7000 lb	235/80R16 8 Hole	24"	4085
83	12	14000	2 X 7000 lb	235/80R16 8 Hole	24"	4425
83	14	14000	2 X 7000 lb	235/80R16 8 Hole	24"	4735
83	16	14000	2 X 7000 lb	235/80R16 8 Hole	24"	4825
83	16	21000	3 X 7000 lb	235/80R16 8 Hole	24"	5200

\*WEIGHT OF UNITS ARE APPROXIMATES ONLY AND SUBJECT TO CHANGE DEPENDING ON OPTIONS

## OPTIONAL FEATURES

CODE	DESCRIPTION	CODE	DESCRIPTION
082	Tandem 8k Axles	W91	Cold Weather Harness
S01	Rear Stabilizer Jacks	J42	2-10K Drop-Leg Jacks
S61	3' Side Walls	J51	Hydraulic 10k Jack
S62	4' Side Walls	S90	Solar Charger (1.5Amp)
X90	24" Solid Side Extensions	V53	3 Stage Telescopic Cylinder
R90	Wireless Remote	V54	3-Way Pump

### DTB OPTIONAL FEATURES



3 Stage Telescopic Cylinder



3' or 4' Sidewalls



Rear Stabilizer Jacks



Retractable Turtle Tarp



Supersized Toolbox



Available three 7k Axles



# DWB MODEL



8" I-Beam Dump Trailer



# 8"

## I-BEAM

Standard Spare Tire Mount

Retractable Tarp System



7Ga Flooring  
24" 10Ga Steel Sides

14Ga Diamond Plate Fenders

3-Way Spreader Gate

Super-sized Front Tool Box

Scissor Hoist with 516 Cylinder

2 5/16" Adjustable Coupler

29" Deck Height

E-Z Lube Hubs

Radial Tires

Cambered Brake Axles

Powdura Powder Coat and One Cure Primer

8" I-Beam Tongue and Frame

17.5"-25.5" Coupler Height

10k Drop-Leg Jack

## 2023 DWB



**SUPER-SIZED FRONT TOOLBOX**



**8" I-BEAM FRAME**



**7GA FLOORING**

\* Features and options may change based on availability



**2023 BASE SPECS**

WIDTH	LENGTH	GVWR	AXLES	TIRE/WHEEL	TONGUE	WEIGHT
83	14	14000	2 X 7000 lb	235/80R16 8 Hole	8" I-Beam	5075
83	16	14000	2 X 7000 lb	235/80R16 8 Hole	8" I-Beam	5250

**AVAILABLE IN STANDARD CONFIGURATIONS ONLY**

8" I-Beam Frame & Tongue (10 lbs/ft )  
 4" Tubing Bed Frame  
 7 Gauge Steel Flooring  
 3 x 3/16" Channel Crossmembers  
 Full Length Bed Runners and Ramp Pockets  
 10 Gauge 18" or 24" Steel Sides  
 Standard Retractable Tarp Kit  
 Weld On Diamond Plate Fenders  
 10k Drop-Leg Jack  
 2 5/16" Adjustable Coupler  
 Cambered Brake Axles  
 Multi-leaf Slipper Spring Suspension  
 Black Mod Wheels  
 Radial Tires  
 Spare Tire Mount  
 Slide-in Ramps

Rear Support Stand Bracket  
 Three-Way Spreader Gate  
 Powdura Powder Coat & One Cure Primer  
 Scissor Hoist with 516 Cylinder  
 Double Acting Pump Unit w/ Gravity Down  
 Flow Control Valve  
 Locking Pump Box  
 Standard Stake Pockets  
 Weld On Diamond Plate Fenders  
 Four Floor Mounted 5/8" D-Rings  
 DOT Approved Lighting  
 Lifetime LED Lighting  
 Molded Sealed Harness with Resistors  
 LED Voltage Indicator in Remote  
 Built-In 5 amp Battery Charger  
 7-Way Receiver Female Plug with Adapter

**AVAILABLE IN STANDARD CONFIGURATIONS ONLY**





# DTG MODEL



## 6" I-Beam Gooseneck Dump Trailer

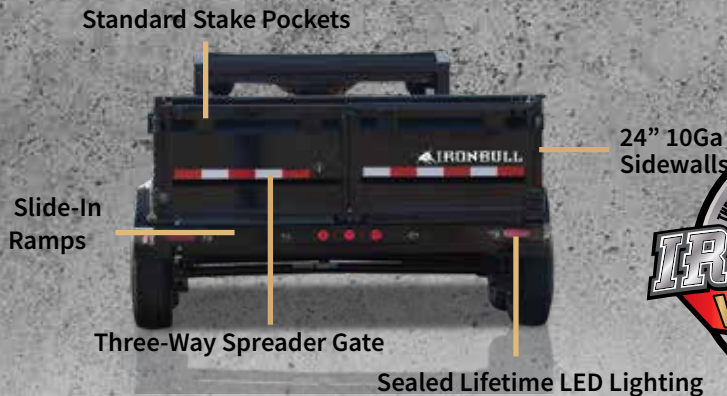

### 2023 DTG

Iron Bull DTG model trailers are built to work. 12" I-Beam neck and risers, 14k - 21K of GVWR and 3" channel crossmembers with 16" centers. Top tier components come together with the most rugged construction on the market to deliver a dump trailer like no other.

#### BOX CAPACITY (CUBIC YARDS)

SIZE	BASE	3FT	4FT
83x12	6.1	9.2	12.3
83x14	7.2	10.8	14.3
83x16	8.2	12.3	16.4



## STANDARD FEATURES

- 6" I-Beam Frame (12lbs/ft)
- 12" I-Beam Neck and Risers
- 7 Gauge Steel Flooring
- 4" Tubing Bed Frame
- Full Length Bed Runners and Ramp Pockets
- 10 Gauge 24" Steel Sides
- Standard Retractable Tarp Kit
- Dual 10k Drop-Leg Jacks
- 2 5/16" Adjustable Coupler
- Cambered Brake Axles
- Multi-leaf Slipper Spring Suspension
- Black Mod Wheels
- Radial Tires
- Spare Tire Mount
- Slide-in Ramps

- Rear Support Stand Bracket
- Three-Way Spreader Gate
- Powdura Powder Coat & One Cure Primer
- Scissor Hoist with 516 Cylinder
- Double Acting Pump Unit w/ Gravity Down
- Flow Control Valve
- Locking Pump Box
- Standard Stake Pockets
- Weld On Diamond Plate Fenders
- Four Floor Mounted 5/8" D-Rings
- DOT Approved Lifetime LED Lighting
- Molded Sealed Harness with Resistors
- LED Voltage Indicator in Remote
- Built-In 5 amp Battery Charger
- 7-Way Receiver Female Plug with Adapter

GRAB A BULL BY THE HORNS



## 2023 BASE SPECS

WIDTH	LENGTH	GVWR	AXLES	TIRE/WHEEL	SIDES	WEIGHT
83	12	14000	2 X 7000 lb	235/80R16 8 Hole	24"	4915
83	14	14000	2 X 7000 lb	235/80R16 8 Hole	24"	5195
83	16	14000	2 X 7000 lb	235/80R16 8 Hole	24"	5400
83	16	21000	3 X 7000 lb	235/80R16 8 Hole	24"	5920

\*WEIGHT OF UNITS ARE APPROXIMATES ONLY AND SUBJECT TO CHANGE DEPENDING ON OPTIONS

## OPTIONAL FEATURES

CODE	DESCRIPTION	CODE	DESCRIPTION
082	Tandem 8k Axles	W91	Cold Weather Harness
R50	Ramps (14k, 21k) 16" x 80"	J55	2 Speed 10K Drop-Leg Jacks
D60	Deck Over Neck	J52	2 12K Hydraulic Jacks
S01	Rear Stabilizer Jacks	S90	Solar Charger (1.5Amp)
X90	24" Solid Side Extensions	R90	Wireless Remote
S61	3' Side Walls	V54	3-Way Pump
S62	4' Side Walls	V53	3 Stage Telescopic Cylinder



Available Rear Supports



7 Gauge Floor Standard



Available Side Extensions



Full Length Bed Runners



3' & 4' Sides Available



Triple Axle Available

Photos may include optional features.



# DDP MODEL



## Deckover Dump with Fold Down Sides

### 2023 DDP

Iron Bull is happy to offer one of the best deckover dumps on the market, expertly made in the USA. Our DDP offers a raised deck to accommodate 10 gauge fold down sides and a bed width of 96". Each deckover is equipped standard with 10" I-Beam frame, 3" channel crossmembers, 10 gauge smooth steel floor, 2 5/16" couplers, a 10k Drop-Leg jack and more.

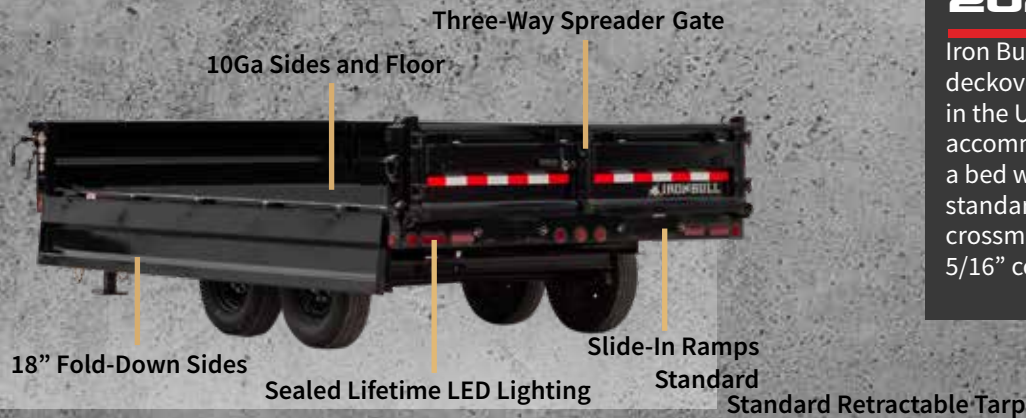

### BOX CAPACITY (CUBIC YARDS)

SIZE	BASE
96x12	5.3
96x14	6.2
96x16	7.1
96x18	8



## STANDARD FEATURES

- 10" x 12lb I-Beam Frame
- 2 5/16" Adjustable Coupler
- 3" Structural Formed Crossmembers
- 10 Gauge Floor
- 18" Fold-Down Sides
- Multi-leaf Slipper Spring Suspension
- E-Z Lube Hubs
- 2 Electric Brake Axles
- Slide-in Ramps
- Cambered Spring Axles
- Three-Way Spreader Gate
- Standard Retractable Tarp Kit
- Locking Pump Box
- Built In 5 Amp Charger

- Standard Stake Pockets
- 10k Drop-Leg Jack
- Scissor Hoist with 520 Cylinder
- Four 5/8" D-Rings
- Double Acting Power Unit w/ Gravity Down
- 5"x20" Hydraulic Cylinder
- Flow Control Valve
- Black Mod Wheels
- 235/80R16 Radial Tires
- DOT Approved Lifetime LED Lighting
- LED Voltage Indicator in Remote
- Molded Sealed Harness with Resistors
- 7-Way Receiver Female Plug with Adapter
- Powdura Powder Coat & One Cure Primer

GRAB A BULL BY THE HORNS



*Deckover Dump with Fold Down Sides*

## 2023 BASE SPECS

WIDTH	LENGTH	GVRW	AXLES	TIRE/WHEEL	FRAME	WEIGHT
96	14	14000	2 X 7000 lb	235/80R16 8 Hole	8" I-Beam	4660
96	16	14000	2 X 7000 lb	235/80R16 8 Hole	8" I-Beam	4870
96	16	21000	3 X 7000 lb	235/80R16 8 Hole	8" I-Beam	5090

\*WEIGHT OF UNITS ARE APPROXIMATES ONLY AND SUBJECT TO CHANGE DEPENDING ON OPTIONS

## OPTIONAL FEATURES

CODE	DESCRIPTION	CODE	DESCRIPTION
082	Tandem 8k Axles	J51	Hydraulic Jack
W91	Cold Weather Harness	R90	Wireless Remote
S90	Solar Panel	V54	3-Way Pump



96" Wide Deck, Standard Tarp



520 Scissor Hoist



Three Way Spreader Gate



36" Deck Height, 18" Fold Down Sides



Triple Axle Available



# DDG MODEL



Deckover GN Dump with Fold Down Sides



## 2023 DDG

Iron Bull is happy to offer one of the best deck-over dumps on the market. Expertly made in the USA, our DDG offers a raised deck to accommodate 10 gauge fold down sides and a bed width of 96". Each deckover is equipped standard with 10" I-Beam frame, 3" channel crossmembers, 10 gauge smooth steel floor, 2 5/16" couplers, a 3-way spreader gate and so much more.

### BOX CAPACITY (CUBIC YARDS)

SIZE	BASE
96x14	6.2
96x16	7.1
96x18	8



## STANDARD FEATURES

- 10" x 12lb I-Beam Frame
- 2 5/16" Adjustable Coupler
- 3" Structural Formed Crossmembers
- 10 Gauge Floor
- 18" Fold-Down Sides
- Multi-leaf Slipper Spring Suspension
- E-Z Lube Hubs
- 2 Electric Brake Axles
- Standard Stake Pockets
- Cambered Spring Axles
- Three-Way Gate
- Standard Retractable Tarp Kit

- Slide-in Ramps
- 2-10k Drop-Leg Jack
- 5"x20" Hydraulic Cylinder
- Scissor Hoist
- Double Acting Power Unit
- Four 5/8" D-Rings
- Black Mod Wheels
- 235/80R16 Radial Tires
- All Lighting DOT Approved
- Molded Sealed Harness with Resistors
- 7-Way Receiver Female Plug with Adapter
- Powdura Powder Coat & One Cure Primer



GRAB A BULL BY THE HORNS



*Deckover GN Dump with Fold Down Sides*

## 2023 BASE SPECS

WIDTH	LENGTH	GVRW	AXLES	TIRE/WHEEL	FRAME	WEIGHT
96	14	14000	2 X 7000 lb	235/80R16 8 Hole	10" I-Beam	5180
96	16	14000	2 X 7000 lb	235/80R16 8 Hole	10" I-Beam	5500
96	18	21000	3 X 7000 lb	235/80R16 8 Hole	10" I-Beam	5780

\*WEIGHT OF UNITS ARE APPROXIMATES ONLY AND SUBJECT TO CHANGE DEPENDING ON OPTIONS

## OPTIONAL FEATURES

CODE	DESCRIPTION	CODE	DESCRIPTION
R50	Ramps (14k,21k) 16"x80" (for deckover dump)	D60	Deck Over Neck
082	Tandem 8k Axles	R90	Wireless Remote
S90	Solar Panel	V54	3-Way Pump
W91	Cold Weather Harness	J52	2 12k Hydraulic Jacks



520 Scissor Hoist



36" Deck Height, 18" Fold Down Sides



Three Way Spreader Gate



Triple Axle Available

Photos may include optional features.



# DSG MODEL



## 22k Tandem Dual Demolition Dump



### 2023 DSG

Nicknamed the “Frankendump,” no job is too big for this monster. With a 33” deck height, 4’ side walls, a spreader gate, a smooth, rounded floor and up to a 25 cubic yard capacity, the DSG will carry whatever you’re hauling.

#### BOX CAPACITY (CUBIC YARDS)

SIZE	BASE
102x16	20.14
102x18	22.67
102x20	25.19

## STANDARD FEATURES

- 12” x 19lb I-Beam Frame & Neck
- 2 5/16” Adjustable Coupler
- 3” Structural Crossmembers
- 10 Gauge Floor and Sides
- 4x144, 16 Ton Telescopic Cylinder
- Heavy Duty Suspension System
- 2-10K Electric Brake Axles
- Multi-leaf Slipper Spring Suspension
- E-Z Lube Hubs
- Standard Retractable Tarp System
- Spreader Gate
- 235/80R16 Spare Tire & Mount

- 2-10k Drop-Leg Jacks
- Four 5/8” D-Rings
- Black Mod Wheels
- 235/80R16 Radial Tires
- Locking Front Toolbox
- Double Acting Power Unit
- DOT Approved Lifetime LED Lighting
- Molded Sealed Harness with Resistors
- 7-Way Receiver Female Plug with Adapter
- Powdura Powder Coat & One Cure Primer



BUILD A QUOTE ONLINE AT [NORSTARCOMPANY.COM](http://NORSTARCOMPANY.COM)

GRAB A BULL BY THE HORNS



## 2023 BASE SPECS

WIDTH	LENGTH	GVRW	AXLES	TIRE/WHEEL	FRAME	WEIGHT
102	16	22000	2 X 10,000 lb	235/80R16 8 Hole	12" I-Beam	7500
102	18	22000	2 X 10,000 lb	235/80R16 8 Hole	12" I-Beam	8130
102	20	22000	2 X 10,000 lb	235/80R16 8 Hole	12" I-Beam	8795

\*WEIGHT OF UNITS ARE APPROXIMATES ONLY AND SUBJECT TO CHANGE DEPENDING ON OPTIONS

## OPTIONAL FEATURES

CODE	DESCRIPTION	CODE	DESCRIPTION
10HS2	2 - 10000 Lb Electric Over Hydraulic Disc Brakes	R90	Wireless Remote
12ES2	2 - 12000 Lb Electric Brake Axles	S90	Solar Panel
15ES2	2 - 15000 Lb Electric Brake Axles	V54	3-Way Pump
15HS2	2 - 15000 Lb Electric Over Hydraulic Brakes	J56	Two 12k Hydraulic Jacks
D60	Deck Over Neck	W91	Cold Weather Harness



Standard HDSS



Up to 15k Tandem Axles



Round Bottom with Spreader Gate

Photos may include optional features.



# DMG MODEL



24,900K Tandem Dual Square Bottom Dump



## SQUARE BOTTOM FLOOR

## ALL-NEW DMG

Built after the DSG "Frankendump," this monster delivers all of the lifting power with its 3 stage 12 ton telescopic cylinder. With a newly designed dump floor that's squared you'll be able to load the biggest of equipment ever. Packed with some serious features, you'll be the talk of the job site.

### BOX CAPACITY (CUBIC YARDS)

SIZE	BASE
102x16	20.14
102x18	22.67
102x20	25.19



T80 Manual Tarp System

144" 14 Ton Telescopic Cylinder

48" 10 Ga Dump Sides

2" X 6" Up Right & Top Rail Tubing

D-Rings (8 Each)

12" 19 Lb I-Beam Neck

Spare Tire & Mount

Sealed Wiring Harness

Safety Chains

2 5/16" 25K Adj Coupler

LED Lighting

Full Front Tool Box

ST 235/80 R16 LRE 10 Ply

2-10 Lb Electric Brake Axles

2-10K Drop Leg Jacks

## STANDARD FEATURES

- 2-10,000 Lb Premium Electric Brake Axles
- 12" 19lb I-Beam Frame
- 12" 19lb I-Beam Riser
- 12" 19lb I-Beam Neck
- 48" 10 Ga Dump Sides
- 25K 2 5/16" Adjustable Gooseneck Coupler
- 2-10K Drop Leg Jacks
- Front Full Tool Box
- Heavy Duty Suspension System
- 3 Stage Telescopic Cylinder (12 tons X 144")
- T80 Tarp System (Front Mount Galvanized Manual)

- Dual Mud Flaps
- Sealed Wiring Harness
- D-Rings 3 X 5/8" (8 Each)
- ST 235/80 R16 LRE 10 Ply
- Spare Tire ST 235/80 R16 LRE 10 Ply
- Stake Pockets
- 2" X 6" Top Rail & Up Right Tubing
- Side Step Plate & Ladder
- HD 16" X 96" Tubing Slide-in Ramps
- Primer Paint & Premium Grey Powder Coat





22k Tandem Dual Dump

**OPTIONAL UPGRADE 12K AXLES FOR 24,900 GVWR**



**96" LONG 2 X 3 1/4" TUBING RAMPS**



**HEAVY DUTY SUSPENSION SYSTEM**



**SIDE STEP LADDER & BARN DOORS**



**T80 MANUAL TARP SYSTEM**



**12" 19 LB FRAME, NECK & RISERS**



**LOCKING BATTERY & PUMP BOX**



# DBG MODEL

14K Roll-Off Dump Trailer



## ALL- NEW DBG

Our DBG is our first ever roll-off dump trailer. Available in bumper pull and gooseneck configurations. Standard with 2- 7k axles, 12" I-beam and a 22k winch and cable system. All backed by our industry leading Iron Clad Warranty.



## DBG STANDARD FEATURES

- 2 - 7,000 Lb Axles Straight (2 Elec. Brakes )
- 10" I-Beam Frame & Neck
- 12" Risers
- 2" X 4" Tube Deck
- 4" X 8" Tube Rear Bumper
- Spare Tire Mount
- 25K 2-5/16" Adjustable Coupler
- Diamond Plate Fenders (Bolt On)
- 2-10K Spring Loaded Drop-Leg Jacks

- Side Step Plate
- Standard Wiring Harness
- ST235/80 R16 LRE 10 Ply.
- 22K Winch With Cable
- Tool Box for Winch With 2 Batteries
- Safety Chain On Deck
- Front Tool Box
- TH-520 Scissor Hoist
- 6" Oval LED Lights





**TH-520 SCISSOR HOIST**



**BARN DOORS**



**STACKABLE BINS**



**48" 10GA DUMP SIDES**

**RB BIN SPECIFICATIONS**

2" X 4" Tube Frame  
 48" 10GA Dump Sides  
 59 3/4" X 83" (Width X Length)  
 10GA Reinforced Upper side  
 10GA Rigid Rail  
 1/4" Stacking Brackets  
 4 1/2" DIA Front & Rear Rollers  
 Rear Barn Doors

Stackable Bins  
 Black Powder Coat and Primer Paint  
 Ranch Grey Powder Coat and Primer Paint  
 Tan Powder Coat and Primer Paint  
 Front Mounted Tarp System  
 7" Stake Pockets  
 3" X 5/8" Weld-On D Rings



# ETB MODEL



## 6" Channel Equipment Trailer



Rampage Ramps (Optional)

Lifetime LED Lighting

### 2023 ETB

The Iron Bull ETB has 14,000 lbs of Gross Vehicle Weight Rating ensure you have enough capacity for your heaviest loads, and expert craftsmanship combined with top-tier components ensure you have an effortless tow. Countless configurations ensure you can get a fit for any job.



Removable Diamond Plate Fenders

10k Drop-Leg Jack Bolt on

Rub Rail & Stake Pockets

Treated Pine 2x6 Floor

2.5 x 2.5 Front Bumper Rail

14"-22" Coupler Height

25" Deck Height

Powdura Powder Coat and One Cure Primer

Radial Tires

Cambered Brake Axles

5", 6" & 8" Channel Frame and Tongue

2 5/16" Adjustable Coupler

## STANDARD FEATURES

- 5", 6" or 8" Channel Tongue & Frame
- 2 5/16" Adjustable Coupler
- 3" Structural Channel Crossmembers
- 2.5 x 2.5 Front Bumper Rail
- Rub Rail & Stake Pockets
- Removable Diamond Plate Fenders
- Cambered Brake Axles
- 2 Electric Brake Axles
- Multi-leaf Slipper Spring Suspension
- Black Mod Wheels \*

- 10k Drop-Leg Jack (7k on 5,500 lb axles)
- 18" x 5' Slide-in Ramps
- Treated Pine 2" x 6" Floor
- 4 Standard 3" D-Rings
- Radial Tires (sizes on p.17)
- Lifetime LED Lighting
- All Lighting DOT Approved
- Molded Sealed Harness with Resistors
- 7-Way Receiver Female Plug with Adapter
- Powdura Powder Coat & One Cure Primer

BUILD A QUOTE ONLINE AT [NORSTARCOMPANY.COM](http://NORSTARCOMPANY.COM)

GRAB A BULL BY THE HORNS



## 2023 BASE SPECS

WIDTH	LENGTH	GVWR	AXLES	TIRE/WHEEL	TONGUE	WEIGHT
83	16	9990	2 X 5200 lb	225/75R15 6 Hole	5" Channel	2350
83	18	9990	2 X 5200 lb	225/75R15 6 Hole	5" Channel	2590
83	20	9990	2 X 5200 lb	225/75R15 6 Hole	5" Channel	2605
83	16	14000	2 X 7000 lb	235/80R16 8 Hole	6" Channel	2760
83	18	14000	2 X 7000 lb	235/80R16 8 Hole	6" Channel	2865
83	20	14000	2 X 7000 lb	235/80R16 8 Hole	6" Channel	3025
83	22	14000	2 X 7000 lb	235/80R16 8 Hole	6" Channel	3125
83	24	14000	2 X 7000 lb	235/80R16 8 Hole	8" Channel	3250
83	26	14000	2 X 7000 lb	235/80R16 8 Hole	8" Channel	3450

\*WEIGHT OF UNITS ARE APPROXIMATES ONLY AND SUBJECT TO CHANGE DEPENDING ON OPTIONS

## OPTIONAL FEATURES

CODE	DESCRIPTION	CODE	DESCRIPTION
ES3	Third Spring Axle (Three Brake Axles) 20'+	E02	Steel Floor (per ft)
082	Tandem 8k Axles	G01	Fork Holders
02	102" Wide Deck (per ft)	U50	Winch Plate 1/2"
D06	2' Dove Tail & Slide In Ramps	W91	Cold Weather Harness
D04	2' Dove & 5' Stand-Up Ramps	S02	Rear Supports (5k Swivel)
D07	3' Dove & Rampage Ramps	T46	Front Tool Box



102 Wide



Steel Floor



Rampage Ramps

Photos may include optional features.



# EWB MODEL



## 8" I-Beam Equipment Trailer



## 2023 EWB



**SUPER-SIZED FRONT TOOLBOX**



**8" I-BEAM FRAME**



**INDUSTRY-BEST WARRANTY**

BUILD A QUOTE ONLINE AT [NORSTARCOMPANY.COM](http://NORSTARCOMPANY.COM)

GRAB A BULL BY THE HORNS



**2023 BASE SPECS**

WIDTH	LENGTH	GVWR	AXLES	TIRE/WHEEL	TONGUE	WEIGHT
83	18	14000	2 X 7000 lb	235/80R16 8 Hole	8" I-Beam	2997
83	20	14000	2 X 7000 lb	235/80R16 8 Hole	8" I-Beam	3136
83	22	14000	2 X 7000 lb	235/80R16 8 Hole	8" I-Beam	3202
83	20	16000	2 X 8000 lb	235/80R16 8 Hole	8" I-Beam	3660
83	22	16000	2 X 8000 lb	235/80R16 8 Hole	8" I-Beam	3748
83	24	16000	2 X 8000 lb	235/80R16 8 Hole	8" I-Beam	3968

**AVAILABLE IN STANDARD CONFIGURATIONS ONLY**

Slide-in, Stand-up Ramps or Rampage Ramps  
 8" I-Beam Frame & Tongue (10 lbs/ft)  
 14,000 lb GVWR  
 Tandem 7k Electric Brake Axles  
 E-Z Lube Hubs  
 235/80 R16 Radial Tires  
 Super-Sized Front Tool Box  
 10k Drop-Leg Bolt-On Jack  
 2"x6" Treated Lumber Flooring  
 Black Mod Wheels  
 8 Weld-On D-Rings  
 Removable 14Ga Diamond Plate Fenders

3" Structural Crossmembers on 16" Centers  
 Integrated Tie-Downs on Front Bump Rail  
 Weld-On 3/8" Safety Chains  
 5 Position 2 5/16" Ball Coupler  
 Lifetime LED Stop, Signal, Marker, & License Plate Lights  
 6 Leaf Spring Suspension  
 DOT Reflective Tape  
 Electric Breakaway Kit with Charger  
 All Lighting DOT Approved  
 Molded Sealed Harness  
 Powdura Powder Coat & One Cure Primer

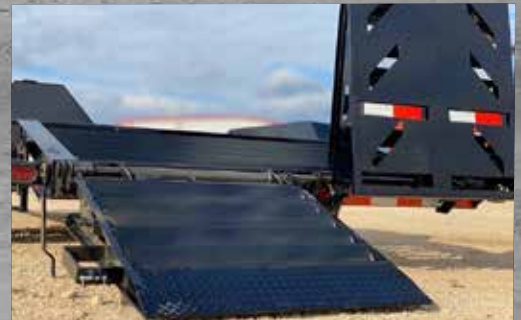



# ETG MODEL



## Gooseneck Equipment Trailer

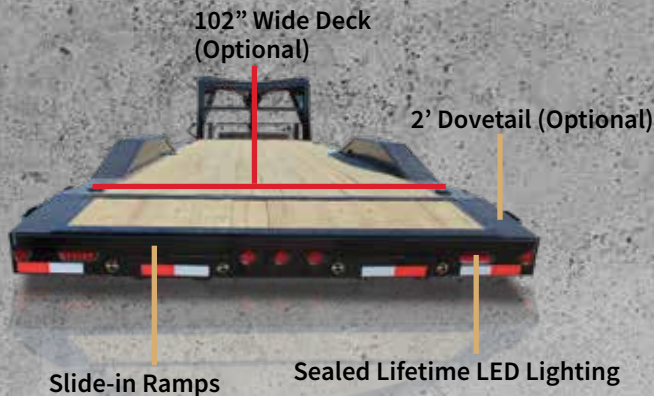

### 2023 ETG

Add some versatility to your fleet with our 14k Gooseneck. With two 7k axles and tons of standard features, Iron Bull equipment goosenecks are a great addition to any farm or jobsite. With tons of options, meet the Jack of all trades.



10" I-Beam Neck and 12" Risers



## STANDARD FEATURES

- 10" I-Beam Neck and 12" Risers
- 2 5/16" Adjustable Coupler
- 3" Structural Channel Crossmembers
- Rub Rail and Stake Pockets
- Removable Diamond Plate Fenders (83" wide)
- Cambered Brake Axles
- Multi-leaf Slipper Spring Suspension
- E-Z Lube Hubs
- 2 Electric Brake Axles
- 5' Slide-in Ramps
- 2 -10k Drop-Leg Jacks

- Treated Pine 2x6 Floor
- 4 Standard 3" D-Rings
- Black Mod Wheels
- Locking Front Toolbox
- 235/80R16 Radial Tires
- Lifetime LED Lighting
- All Lighting DOT Approved
- Molded Sealed Harness with Resistors
- 7-Way Receiver Female Plug with Adapter
- Powdura Powder Coat & One Cure Primer

BUILD A QUOTE ONLINE AT [NORSTARCOMPANY.COM](http://NORSTARCOMPANY.COM)

GRAB A BULL BY THE HORNS



## 2023 BASE SPECS

WIDTH	LENGTH	GVWR	AXLES	TIRE/WHEEL	TONGUE	WEIGHT
83	20	14000	2 X 7000 lb	235/80R16 8 Hole	6" Channel	3790
83	22	14000	2 X 7000 lb	235/80R16 8 Hole	6" Channel	4090
83	24	14000	2 X 7000 lb	235/80R16 8 Hole	8" Channel	4205
83	26	14000	2 X 7000 lb	235/80R16 8 Hole	8" Channel	4600
83	28	14000	2 X 7000 lb	235/80R16 8 Hole	8" Channel	4700
83	30	14000	2 X 7000 lb	235/80R16 8 Hole	8" Channel	4770
83	32	14000	2 X 7000 lb	235/80R16 8 Hole	10" Channel	5020
83	32	21000	3 X 7000 lb	235/80R16 8 Hole	10" Channel	5230
83	34	21000	3 X 7000 lb	235/80R16 8 Hole	10" Channel	6375
83	36	21000	3 X 7000 lb	235/80R16 8 Hole	10" Channel	6600
83	38	21000	3 X 7000 lb	235/80R16 8 Hole	10" Channel	6900
83	40	21000	3 X 7000 lb	235/80R16 8 Hole	10" Channel	7400
83	42	21000	3 X 7000 lb	235/80R16 8 Hole	10" Channel	7620
83	44	21000	3 X 7000 lb	235/80R16 8 Hole	10" Channel	7845

\*WEIGHT OF UNITS ARE APPROXIMATES ONLY AND SUBJECT TO CHANGE DEPENDING ON OPTIONS

## OPTIONAL FEATURES

CODE	DESCRIPTION	CODE	DESCRIPTION
082	Tandem 8k Axles	G01	Fork Holders
02	102" Wide Deck (per ft)	E02	Steel Floor (per ft)
D06	2' Dove Tail & Slide In Ramps	J55	2 Speed Drop-Leg Jacks
D08	4' Dove Tail & Slide In Ramps	U52	Winch Plate 1/2" (in neck)
D04	2' Dove & Stand Up Ramps	S02	Rear Supports (5k Swivel Jacks)
D13	4' Dove & Rampage Ramps	D60	Deck Over Neck



102 Wide, Triple Axle



Rampage Ramps



7K Tandem Axles



# FDG14 MODEL



14k 10" I-Beam Deckover Gooseneck



## 2023 FDG14

Our FDG14 Gooseneck features a 10" I-Beam frame and neck. Our deckover goosenecks come standard with a long list of great features to get your day-to-day tasks complete. See our FTG model for 12" I-Beam frame and longer length decks.

## STANDARD FEATURES

- 10" x 12lb I-Beam Frame
- 2 5/16" Adjustable Coupler
- 3" Structural Channel Crossmembers
- 6" Tubing Outer Rails
- Rub Rail, Stake Pockets & Pipe Spools
- Diamond Plate Fender Plates
- Cambered Spring Axles
- Multi-leaf Slipper Spring Suspension
- Treated Pine 2x6 Floor
- 2 Electric Brake Axles

- Dual Stirrup Steps
- 2 - 10k Drop-Leg Jacks
- 8' Slide-in Ramps
- 4 Standard 3" D-Rings
- Black Mod Wheels
- 235/80R16 Radial Tires
- Lifetime LED Lighting
- All Lighting DOT Approved
- 7-Way Receiver Female Plug with Adapter
- Powdura Powder Coat & One Cure Primer

BUILD A QUOTE ONLINE AT [NORSTARCOMPANY.COM](http://NORSTARCOMPANY.COM)

GRAB A BULL BY THE HORNS



14k 10" I-Beam Deckover Gooseneck

## 2023 BASE SPECS

WIDTH	LENGTH	GVRW	AXLES	TIRE/WHEEL	FRAME	WEIGHT
102	20	14000	2 X 7000 lb	235/80R16	10" (12lb/ft)	4460
102	22	14000	2 X 7000 lb	235/80R16	10" (12lb/ft)	4660
102	24	14000	2 X 7000 lb	235/80R16	10" (12lb/ft)	4910
102	25	14000	2 X 7000 lb	235/80R16	10" (12lb/ft)	5410
102	26	14000	2 X 7000 lb	235/80R16	10" (12lb/ft)	5550
102	28	14000	2 X 7000 lb	235/80R16	10" (12lb/ft)	5750
102	30	14000	2 X 7000 lb	235/80R16	10" (12lb/ft)	5420
102	32	14000	2 X 7000 lb	235/80R16	10" (12lb/ft)	5437

\*WEIGHT OF UNITS ARE APPROXIMATES ONLY AND SUBJECT TO CHANGE DEPENDING ON OPTIONS

## OPTIONAL FEATURES

CODE	DESCRIPTION	CODE	DESCRIPTION
U52	Winch Plate 1/2" (in neck)	J55	2 Speed Drop-Leg Jacks
ESB	2 - 8,000 Lb Axles (2 Elec. Brakes)	E02	Steel Floor (per ft.)
D30	5' Dove & 5' Rampage Ramps	D60	Deck Over Neck



Photos may include optional features.



# FDP14 MODEL



14k 10" I-Beam Pintle Equipment Trailer



## 2023 FDP14

Our FDP14 Deckover Pintle features a 10" I-Beam frame and tongue. Our traditional deckovers come standard with 2 7k axles, 10k jacks, treated pine floor, 33" deck height, lifetime LED lighting, 8' Slide-in Ramps and more.

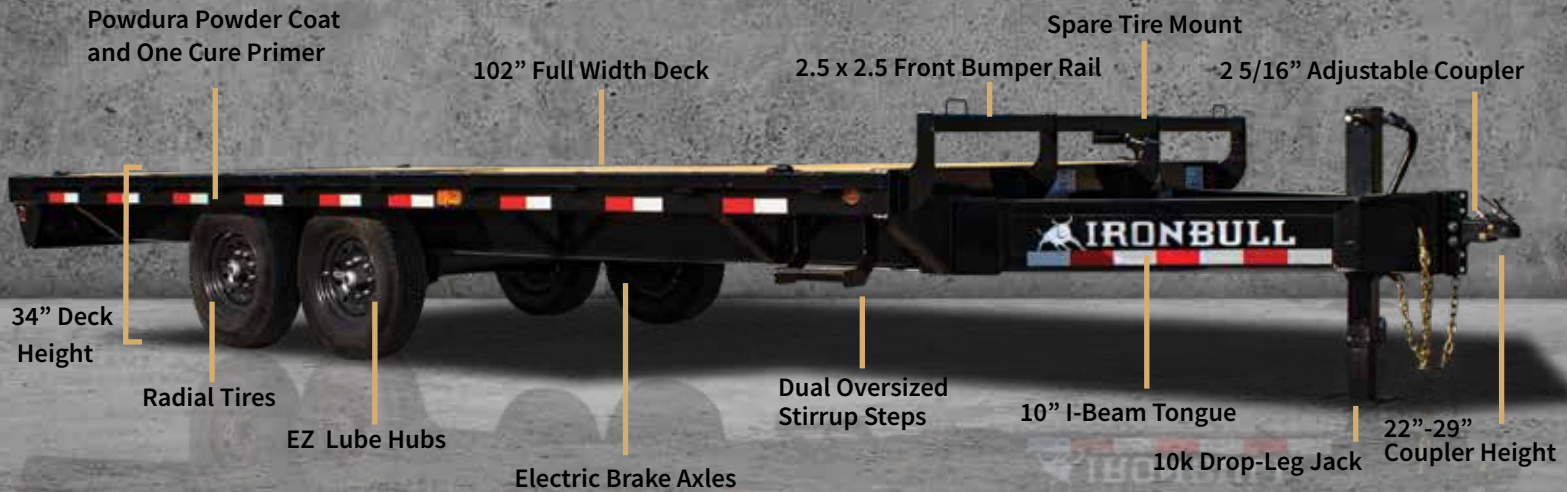

## STANDARD FEATURES

- 10" I-Beam Frame and Tongue
- 2 5/16" Adjustable Coupler
- 3" Structural Crossmembers
- Deck Height 33"
- Rub Rail, Stake Pockets & Pipe Spools
- 2 Electric Brake Axles
- Cambered Spring Axles
- E-Z Lube Hubs
- Multi-leaf Slipper Spring Suspension
- Full 102' Wide Deckover
- 8' Slide-in Ramps

- Dual Stirrup Steps
- 10k Drop-Leg Jack
- Treated Pine 2x6 Floor
- 4 Standard 3" D-Rings
- Black Mod Wheels
- 235/80R16 Radial Tires
- Lifetime LED Lighting
- All Lighting DOT Approved
- Molded Sealed Harness with Resistors
- 7-Way Receiver Female Plug with Adapter
- Powdura Powder Coat & One Cure Primer

BUILD A QUOTE ONLINE AT [NORSTARCOMPANY.COM](http://NORSTARCOMPANY.COM)

GRAB A BULL BY THE HORNS



## 2023 BASE SPECS

WIDTH	LENGTH	GVRW	AXLES	TIRE/WHEEL	FRAME	WEIGHT
102	16	14000	2 X 7000 lb	235/80R16 8 Hole	10" (12lb/ft)	4615
102	18	14000	2 X 7000 lb	235/80R16 8 Hole	10" (12lb/ft)	4715
102	20	14000	2 X 7000 lb	235/80R16 8 Hole	10" (12lb/ft)	4815
102	22	14000	2 X 7000 lb	235/80R16 8 Hole	10" (12lb/ft)	4915
102	24	14000	2 X 7000 lb	235/80R16 8 Hole	10" (12lb/ft)	4900
102	25	14000	2 X 7000 lb	235/80R16 8 Hole	10" (12lb/ft)	5020
102	26	14000	2 X 7000 lb	235/80R16 8 Hole	10" (12lb/ft)	5220
102	28	14000	2 X 7000 lb	235/80R16 8 Hole	10" (12lb/ft)	5420

\*WEIGHT OF UNITS ARE APPROXIMATES ONLY AND SUBJECT TO CHANGE DEPENDING ON OPTIONS

## OPTIONAL FEATURES

CODE	DESCRIPTION	CODE	DESCRIPTION
ES3	Third Spring Axle (Three Electric Brakes)	E04	Rough Oak Flooring (per ft.)
08	2 - 8,000 Lb Axles (2 Elec. Brakes)	E02	Steel Floor (per ft.)
D30	5' Dove & 5' Rampage Ramps	U50	Winch Plate (Floor)
J55	2 Speed Drop-Leg Jacks	T46	Tongue Mount Toolbox



Photos may include optional features.

5500 FM 38N, BROOKSTON, TX 75421



# FTG14 MODEL



14k 12" I-Beam Deckover Gooseneck

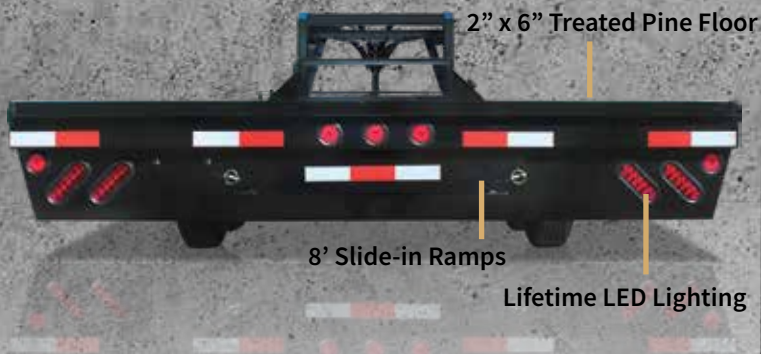

## 2023 FTG14

Our FTG14 Gooseneck features a 12" I-Beam frame and neck. The heavier frame and structure allow for longer lengths and triple axle configurations in comparison to our FDG14 model that feature a 10" I-Beam frame and neck.

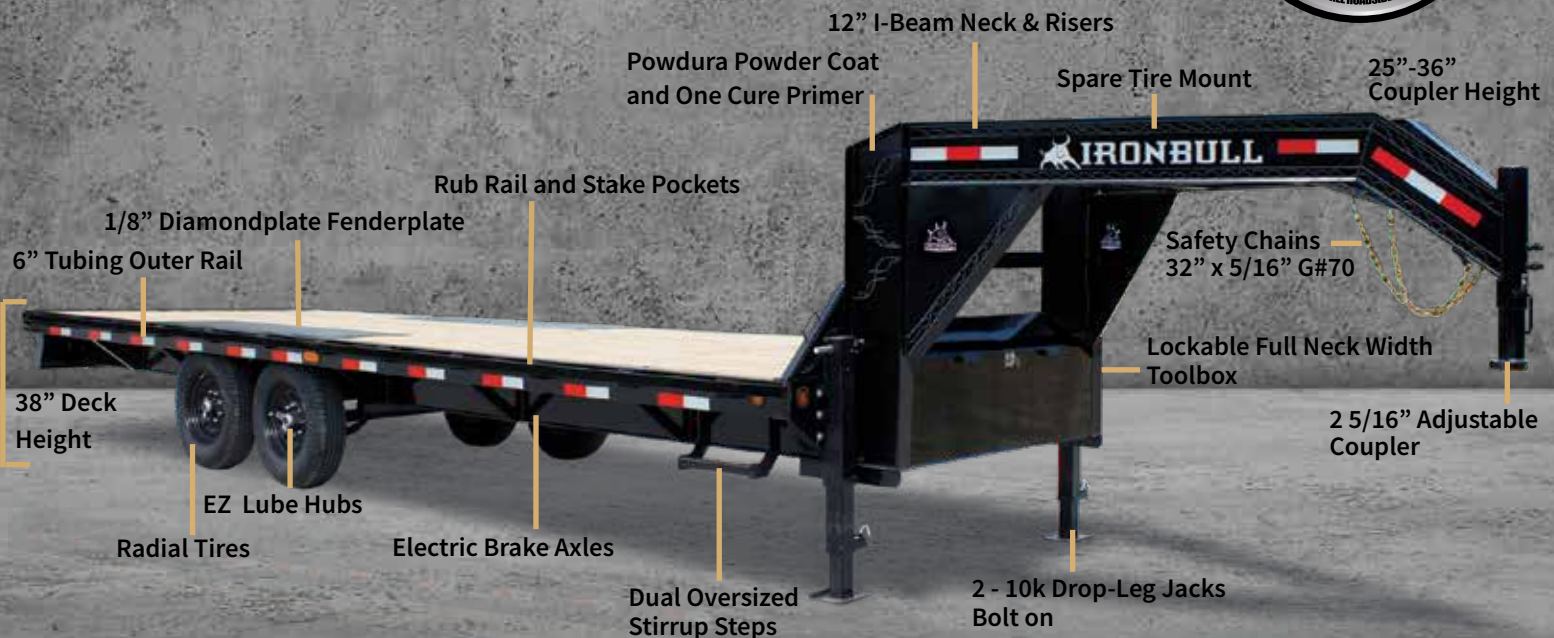

## STANDARD FEATURES

- 12" x 14lb I-Beam Frame
- 2 5/16" Adjustable Coupler
- 3" Structural Channel Crossmembers
- 6" Tubing Outer Rails
- Rub Rail, Stake Pockets & Pipe Spools
- Diamond Plate Fender Plates
- Cambered Spring Axles
- Multi-leaf Slipper Spring Suspension
- Treated Pine 2x6 Floor
- 2 Electric Brake Axles

- Dual Stirrup Steps
- 2 - 10k Drop-Leg Jacks
- 8' Slide-in Ramps
- 4 Standard 3" D-Rings
- Black Mod Wheels
- 235/80R16 Radial Tires
- Lifetime LED Lighting
- All Lighting DOT Approved
- 7-Way Receiver Female Plug with Adapter
- Powdura Powder Coat & One Cure Primer

BUILD A QUOTE ONLINE AT [NORSTARCOMPANY.COM](http://NORSTARCOMPANY.COM)

GRAB A BULL BY THE HORNS



14k 12" I-Beam Deckover Gooseneck

## 2023 BASE SPECS

WIDTH	LENGTH	GVRW	AXLES	TIRE/WHEEL	FRAME	WEIGHT
102	20	14000	2 X 7000 lb	235/80R16	12" (14lb/ft)	
102	22	14000	2 X 7000 lb	235/80R16	12" (14lb/ft)	
102	24	14000	2 X 7000 lb	235/80R16	12" (14lb/ft)	
102	25	14000	2 X 7000 lb	235/80R16	12" (14lb/ft)	5650
102	26	14000	2 X 7000 lb	235/80R16	12" (14lb/ft)	6120
102	28	14000	2 X 7000 lb	235/80R16	12" (14lb/ft)	6360
102	30	14000	2 X 7000 lb	235/80R16	12" (14lb/ft)	6730
102	32	14000	2 X 7000 lb	235/80R16	12" (14lb/ft)	6930
102	34	14000	2 X 7000 lb	235/80R16	12" (14lb/ft)	7078
102	36	14000	2 X 7000 lb	235/80R16	12" (14lb/ft)	7256
102	38	21000	3 X 7000 lb	235/80R16	12" (14lb/ft)	7500
102	40	21000	3 X 7000 lb	235/80R16	12" (14lb/ft)	7657

\*WEIGHT OF UNITS ARE APPROXIMATES ONLY AND SUBJECT TO CHANGE DEPENDING ON OPTIONS

## OPTIONAL FEATURES

CODE	DESCRIPTION	CODE	DESCRIPTION
ES3	Third Spring Axle (Three Electric Brakes)	J55	2 Speed Drop-Leg Jacks
ESB	2 - 8,000 Lb Axles (2 Elec. Brakes)	E02	Steel Floor (per ft.)
D30	5' Dove & 5' Rampage Ramps	D60	Deck Over Neck
U52	Winch Plate 1/2" (in neck)	E04	Rough Oak Flooring (per ft.)



Photos may include optional features.



# FHG22 MODEL



## 22k Gooseneck Hydraulic Dove Trailer



### 2023 FHG22

Meet the newest addition to the Iron Bull lineup – the FHG. Our revolutionary new design of the traditional hydraulic dove tail is sure to be the biggest workhorse in your stable.



## STANDARD FEATURES

- 12" I-Beam Frame and Neck (19 lbs/ft)
- 2 5/16" Adjustable Coupler
- 3" Structural Crossmembers
- Rub Rail, Stake Pockets & Pipe Spools
- HDSS Standard
- 2-10K Electric Brake Axles
- Multi-leaf Slipper Spring Suspension
- E-Z Lube Hubs
- Standard Torque Tube & Pipe Bridge
- Powdura Powder Coat & One Cure Primer
- Spare Tire & Mount

- 2 - 10k Drop-Leg Jacks
- Treated Pine 2" x 6" Floor
- 4 Standard 3" D-Rings
- Black Mod Wheels
- 235/80R16 Radial Tires
- Lifetime LED Lighting
- All Lighting DOT Approved
- Molded Sealed Harness with Resistors
- 7-Way Receiver Female Plug with Adapter

BUILD A QUOTE ONLINE AT [NORSTARCOMPANY.COM](http://NORSTARCOMPANY.COM)

GRAB A BULL BY THE HORNS



## 2023 BASE SPECS

WIDTH	LENGTH	GVRW	AXLES	TIRE/WHEEL	FRAME	WEIGHT
102	28	22000	2 X 10,000 lb	235/80R16 8 Hole	12" (19lb/ft)	7620
102	30	22000	2 X 10,000 lb	235/80R16 8 Hole	12" (19lb/ft)	7945
102	32	22000	2 X 10,000 lb	235/80R16 8 Hole	12" (19lb/ft)	8105
102	34	22000	2 X 10,000 lb	235/80R16 8 Hole	12" (19lb/ft)	9490
102	36	22000	2 X 10,000 lb	235/80R16 8 Hole	12" (19lb/ft)	9690
102	38	22000	2 X 10,000 lb	235/80R16 8 Hole	12" (19lb/ft)	9890
102	40	22000	2 X 10,000 lb	235/80R16 8 Hole	12" (19lb/ft)	10000

\*WEIGHT OF UNITS ARE APPROXIMATES ONLY AND SUBJECT TO CHANGE DEPENDING ON OPTIONS

## OPTIONAL FEATURES

CODE	DESCRIPTION	CODE	DESCRIPTION
10HS2	2 - 10000 Lb Electric Over Hydraulic Disc Axles	J56	2 12k Hydraulic Jacks
12ES2	2 - 12000 Lb Electric Brake Axles	H72	6' Spread Axles
12HS2	2 - 12000 Lb Electric Over Hydraulic Disc Brake	K21	12" Crossmembers (per ft)
15ES2	2 - 15000 Lb Electric Brake Axles	D60	Deck Over Neck
15AS2	2 - 15000 Lb Air Ride Axles	T42	Additional Side Tool Box (ea.)
10ES3	3 - 10000 Lb Electric Brake Axles	J55	2 Speed Drop-Leg Jacks
10HS3	3 - 10000 Lb Electric Over Hydraulic Brake Axles	W91	Cold Weather Harness
12ES3	3 - 12000 Lb Electric Brake Axles	T21	17.5"x6.75" Tire Upgrade (ea.)
12HS3	3 - 12000 Lb Electric Over Hydraulic Brake Axles	U30	Weld On Ratchet Track Only (per ft)
D96	9' Hydraulic Dove Tail with Cleats on OUTSIDE ONLY	U32	Weld On Ratchets Every 5' (per ft)
D97	9' Hydraulic Dove Tail with Cleats FULL TAIL	U33	Weld On Track with Adjustable Ratchets Every 5'
D98	9' Hydraulic Dove SELF CLEANING OUTSIDE ONLY	R90	Wireless Remote
D99	9' Hydraulic Dove FULL SELF CLEANING	U52	Winch Plate 1/2" (in neck)
D95	9' Hydraulic Dove Tail Blackwood OUTSIDE ONLY	T06	14-Ply 235/85 Tire Upgrade (ea.)



Blackwood Floor Option



Up to 15k Axles



D98 Self Cleaning with Cleats Outside



# FLG22 MODEL



22k Gooseneck Low-Pro Equipment Trailer

## 2023 FLG22

Iron Bull Goosenecks are some of the most rugged and longest lasting units in service today. Low-Pro, pierced frame design lowers the deck 3" providing a lower center of gravity, more stable cornering and a lower loading angle for equipment.



**OPTIONAL**



## STANDARD FEATURES

- 12" I-Beam Frame and Neck (19 lbs/ft)
- 2 5/16" Adjustable Coupler
- 3" Structural Crossmembers
- 2.5 x 2.5 Front Bumper Rail
- Lockable Full Neck Width Tool Box
- Rub Rail, Stake Pockets & Pipe Spools
- Standard Torque Tube & Underframe Bridge
- HDSS Standard
- 2-10K Electric Brake Axles
- Multi-leaf Slipper Spring Suspension
- E-Z Lube Hubs
- 25" Gooseneck Box

- 8' Slide-in Ramps
- 2-10k Drop-Leg Jack
- Treated Pine 2x6 Floor
- 4 Standard 3" D-Rings
- Black Mod Wheels
- 235/80R16 Radial Tires
- Spare Tire & Mount
- Lifetime LED Lighting
- All Lighting DOT Approved
- Molded Sealed Harness with Resistors
- 7-Way Receiver Female Plug with Adapter
- Powdura Powder Coat & One Cure Primer

BUILD A QUOTE ONLINE AT [NORSTARCOMPANY.COM](http://NORSTARCOMPANY.COM)

GRAB A BULL BY THE HORNS



### 2023 BASE SPECS

WIDTH	LENGTH	GVWR	AXLES	TIRE/WHEEL	FRAME	WEIGHT
102	20	22000	2 X 10,000 lb	235/80R16 8 Hole	12" (19lb/ft)	6300
102	22	22000	2 X 10,000 lb	235/80R16 8 Hole	12" (19lb/ft)	6600
102	24	22000	2 X 10,000 lb	235/80R16 8 Hole	12" (19lb/ft)	6920
102	25	22000	2 X 10,000 lb	235/80R16 8 Hole	12" (19lb/ft)	7310
102	26	22000	2 X 10,000 lb	235/80R16 8 Hole	12" (19lb/ft)	7410
102	28	22000	2 X 10,000 lb	235/80R16 8 Hole	12" (19lb/ft)	7640
102	30	22000	2 X 10,000 lb	235/80R16 8 Hole	12" (19lb/ft)	7855
102	32	22000	2 X 10,000 lb	235/80R16 8 Hole	12" (19lb/ft)	8105
102	34	22000	2 X 10,000 lb	235/80R16 8 Hole	12" (19lb/ft)	8350
102	36	22000	2 X 10,000 lb	235/80R16 8 Hole	12" (19lb/ft)	8675
102	38	22000	2 X 10,000 lb	235/80R16 8 Hole	12" (19lb/ft)	8900
102	40	22000	2 X 10,000 lb	235/80R16 8 Hole	12" (19lb/ft)	9200

\*WEIGHT OF UNITS ARE APPROXIMATES ONLY AND SUBJECT TO CHANGE DEPENDING ON OPTIONS

### OPTIONAL FEATURES

CODE	DESCRIPTION	CODE	DESCRIPTION
10HS2	2 - 10000 Lb Electric Over Hydraulic Disc Axles	K21	12" Crossmembers (per ft)
12ES2	2 - 12000 Lb Electric Brake Axles	H72	6' Spread Axles
12HS2	2 - 12000 Lb Electric Over Hydraulic Disc Brake Axles	D60	Deck Over Neck
15ES2	2 - 15000 Lb Electric Brake Axles	T42	Side Tool Box
15AS2	2 - 15000 Lb Air Ride Axles	J55	Drop-Leg Jack (2-Speed)
10ES3	3 - 10000 Lb Electric Brake Axles	W91	Cold Weather Harness
10HS3	3 - 10000 Lb Electric Over Hydraulic Brake Axles	J56	2 - 12k Hydraulic Jacks
12ES3	3 - 12000 Lb Electric Brake Axles	U30	Weld On Ratchet Track Only (per ft)
12HS3	3 - 12000 Lb Electric Over Hydraulic Brake Axles	U32	Weld On Ratchets Every 5' (per ft)
D30	Rampage Ramps (2 - 40" Flip-Over Ramps with 5' Self Cleaning Dove)	U31	Weld On Track with Adjustable Ratchets Every 5' (ft)
D35	5' Self Cleaning Dove Tail with Slide-in Ramps	T06	14-Ply 235/85 Tire Upgrade (ea.)
D31	5' Self Cleaning Dove Tail with 2 Flip-Over Ramps	T21	17.5"x6.75" Tire Upgrade (ea.)
D32	5' Self Cleaning Dove Tail with 3. Flip-Over Ramps	U52	Winch Plate 1/2" (In Neck)
S01	Tube Rear Support Stands		

### 2023 FLG22 Optional Features



Rampage Ramps



Triple Axle Configurations



2 - 12K Electric Brake Axles



# FLP22 MODEL



## 22k Deckover Pintle Trailer

**OPTIONAL**

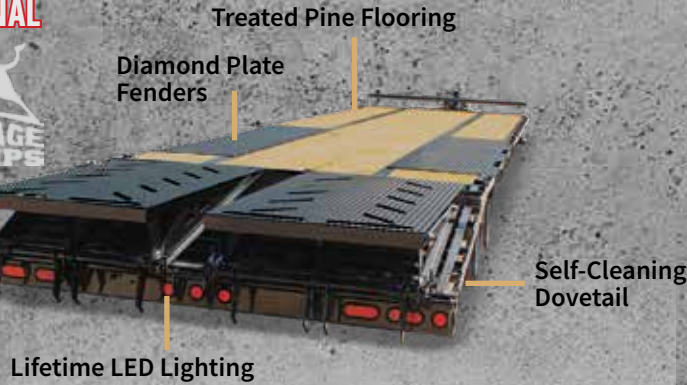

## 2023 FLP22

We designed our FLP22 Heavy Pintle with the idea of making things easier for the customer. With up to 3 15k axles, optional Rampage Ramps, 3" 60k pintle eye coupler and a self-cleaning dovetail, the FLP22 makes hauling even the heaviest machinery a smooth ride.



Optional 3rd Axle

Powdura Powder Coat and One Cure Primer

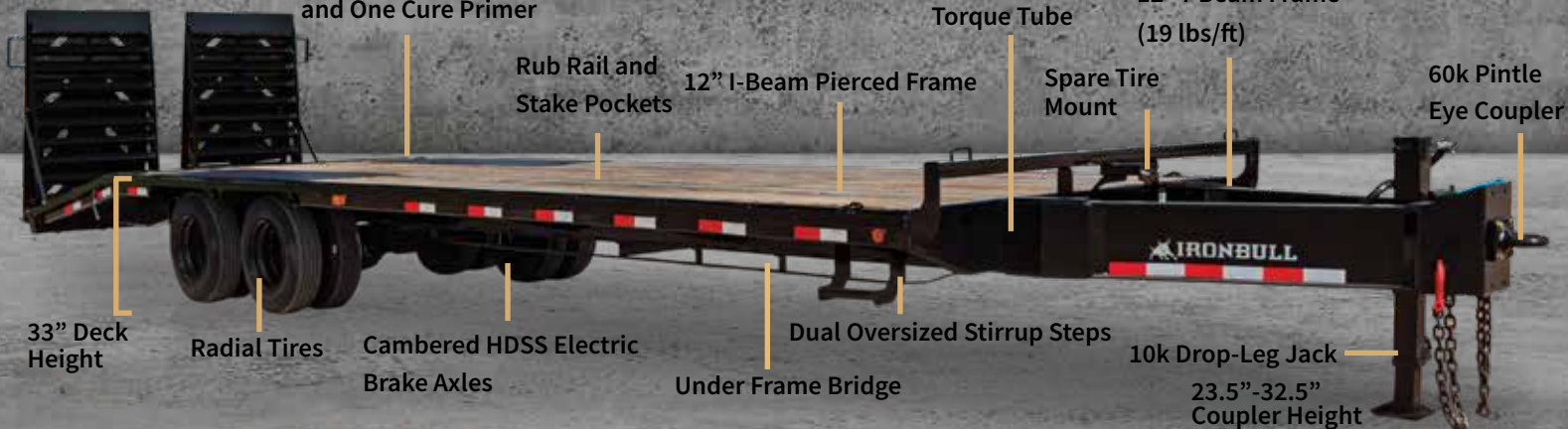

## STANDARD FEATURES

- 12" I-Beam Frame (19 lbs/ft)
- 60k Pintle Eye Coupler
- 3" Structural Crossmembers
- 2.5 x 2.5 Front Bumper Rail
- Rub Rail, Stake Pockets & Pipe Spools
- Standard Torque Tube & Underframe Bridge
- Heavy Duty Suspension System Standard
- 2-10K Electric Brake Axles
- Multi-leaf Slipper Spring Suspension
- E-Z Lube Hubs

- 8' Slide-in Ramps
- 2-10k Drop-Leg Jacks
- Treated Pine 2x6 Floor
- 4 Standard 3" D-Rings
- Black Mod Wheels
- 235/80R16 Radial Tires
- Lifetime LED Lighting
- All Lighting DOT Approved
- Molded Sealed Harness with Resistors
- 7-Way Receiver Female Plug with Adapter
- Powdura Powder Coat & One Cure Primer

BUILD A QUOTE ONLINE AT [NORSTARCOMPANY.COM](http://NORSTARCOMPANY.COM)

GRAB A BULL BY THE HORNS



22k Deckover Pintle Trailer

## 2023 BASE SPECS

WIDTH	LENGTH	GVWR	AXLES	TIRE/WHEEL	FRAME	WEIGHT
102	20	22000	2 X 10,000 lb	235/80R16 8 Hole	12" (19lb/ft)	6270
102	22	22000	2 X 10,000 lb	235/80R16 8 Hole	12" (19lb/ft)	6456
102	24	22000	2 X 10,000 lb	235/80R16 8 Hole	12" (19lb/ft)	6550
102	25	22000	2 X 10,000 lb	235/80R16 8 Hole	12" (19lb/ft)	6656
102	26	22000	2 X 10,000 lb	235/80R16 8 Hole	12" (19lb/ft)	6770
102	28	22000	2 X 10,000 lb	235/80R16 8 Hole	12" (19lb/ft)	6856
102	30	22000	2 X 10,000 lb	235/80R16 8 Hole	12" (19lb/ft)	7056
102	32	22000	2 X 10,000 lb	235/80R16 8 Hole	12" (19lb/ft)	7256
102	34	22000	2 X 10,000 lb	235/80R16 8 Hole	12" (19lb/ft)	7456
102	36	22000	2 X 10,000 lb	235/80R16 8 Hole	12" (19lb/ft)	7656
102	38	22000	2 X 10,000 lb	235/80R16 8 Hole	12" (19lb/ft)	7856
102	40	22000	2 X 10,000 lb	235/80R16 8 Hole	12" (19lb/ft)	8156

\*WEIGHT OF UNITS ARE APPROXIMATES ONLY AND SUBJECT TO CHANGE DEPENDING ON OPTIONS

Photos may include optional features.

## OPTIONAL FEATURES

CODE	DESCRIPTION	CODE	DESCRIPTION
10HS2	2 - 10000 Lb Electric Over Hydraulic Disc Axles	K21	12" Crossmembers (per ft)
12ES2	2 - 12000 Lb Electric Brake Axles	H72	6' Spread Axles
12HS2	2 - 12000 Lb Electric Over Hydraulic Disc Brake Axles	S01	Tube Rear Support Stands
15ES2	2 - 15000 Lb Electric Brake Axles	T42	Side Tool Box
15AS2	2 - 15000 Lb Air Ride Axles	T46	Tongue Mount Toolbox
10ES3	3 - 10000 Lb Electric Brake Axles	J55	Drop-Leg Jack (2-Speed)
10HS3	3 - 10000 Lb Electric Over Hydraulic Brake Axles	W91	Cold Weather Harness
12ES3	3 - 12000 Lb Electric Brake Axles	U50	Winch Plate (Floor)
12HS3	3 - 12000 Lb Electric Over Hydraulic Brake Axles	U30	Weld On Ratchet Track Only (per ft)
D30	Rampage Ramps (2-40" Flip-Over Ramps with 5' Self Cleaning Dove	U32	Weld On Ratchets Every 5' (per ft)
D35	5' Self Cleaning Dove Tail with Slide-in Ramps	U31	Weld On Track with Adjustable Ratchets Every 5' (ft)
D31	5' Self Cleaning Dove Tail with 2 Flip-Over Ramps	T06	14-Ply 235/85 Tire Upgrade (ea.)
D32	5' Self Cleaning Dove Tail with 3. Flip-Over Ramps	T21	17.5"x6.75" Tire Upgrade (ea.)



5500 FM 38N, BROOKSTON, TX 75421



# FLP50 MODEL



Super HD Pintle Trailer

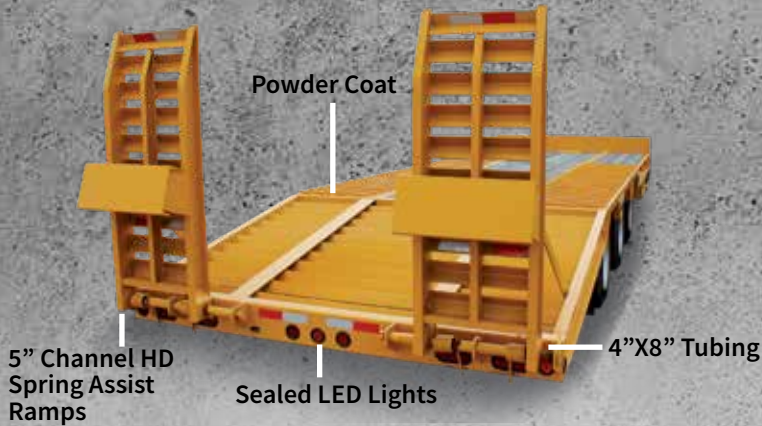

## 2023 FLP50

Heavy hauling just met its match with the FLP50. With up to a 50000 GVRW, 102" deck width, up to 3 axles, coupled with a 14" I-Beam frame and 6" Junior I-Beam Crossmembers you'll be hard-pressed to find something this beast can't carry. Loading and unloading is half the battle, and we thought about that too with a 6' self-cleaning dove tail and HD spring assist ramps std., the FLP almost makes it look easy.

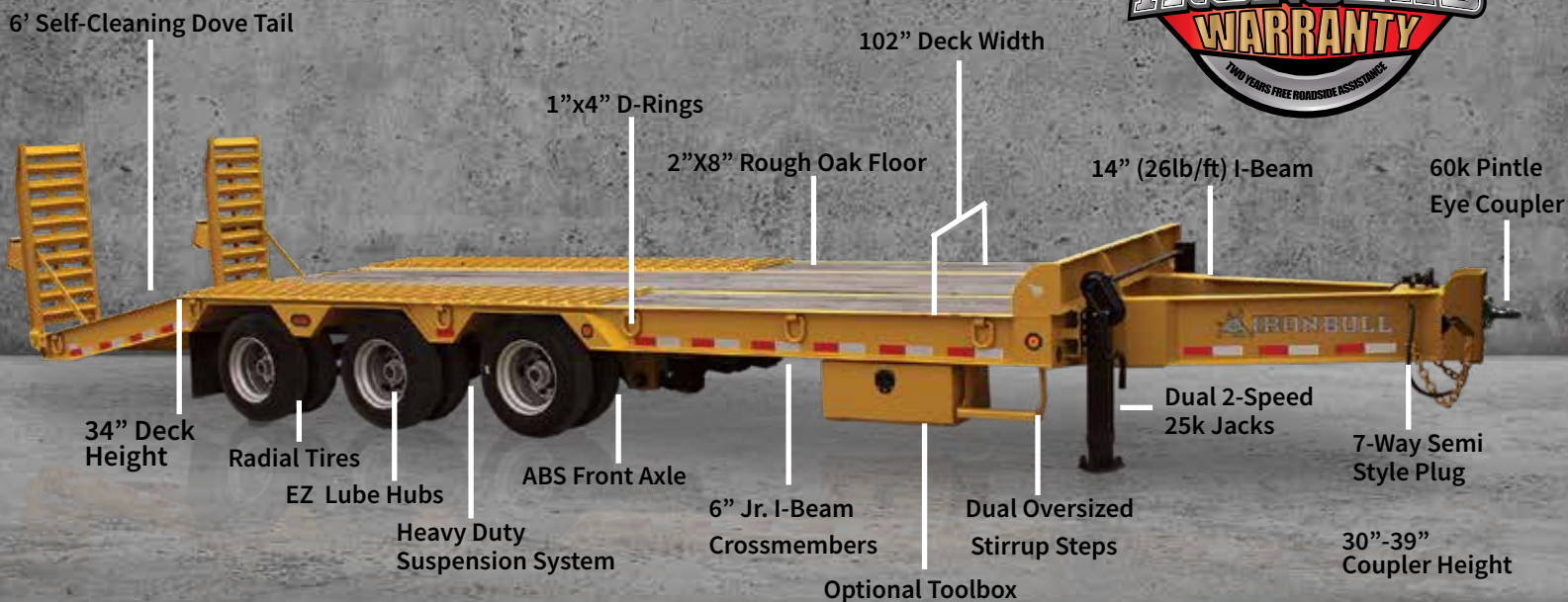

## STANDARD FEATURES

- 14" (26lb/ft) I-Beam Frame
- 2"X8" Treated Wood Floor
- Dual 2-Speed 25k Jacks
- 6' Dove Tail with Spring Assist Ramps
- 6" Jr. I-Beam Crossmembers
- Heavy Duty Suspension System
- 2-10K Electric Brake Axles
- Multi-leaf Slipper Spring Suspension
- E-Z Lube Hubs
- ABS on Front Axle

- 1"x4" D-Rings
- Integrated Bumper Tie-Downs
- Black Mod Wheels
- ST 215/75R17.5 LRH Radial Tires
- 60k Pintle Eye Coupler
- Lifetime LED Lighting
- All Lighting DOT Approved
- Molded Sealed Harness with Resistors
- 7-Way Semi-Style Plug
- Powdura Powder Coat & One Cure Primer

BUILD A QUOTE ONLINE AT [NORSTARCOMPANY.COM](http://NORSTARCOMPANY.COM)

GRAB A BULL BY THE HORNS



## 2023 BASE SPECS

WIDTH	LENGTH	GVRW	AXLES	TIRE/WHEEL	FRAME	WEIGHT
102	25	48000	2 X 22,500 lb	ST 215/75R17.5 LRH	14" (26lb/ft)	7095
102	26	48000	2 X 22,500 lb	ST 215/75R17.5 LRH	14" (26lb/ft)	7295
102	28	48000	2 X 22,500 lb	ST 215/75R17.5 LRH	14" (26lb/ft)	7495
102	30	48000	2 X 22,500 lb	ST 215/75R17.5 LRH	14" (26lb/ft)	7695
102	25	50000	3 X 22,500 lb	ST 215/75R17.5 LRH	14" (26lb/ft)	8995
102	26	50000	3 X 22,500 lb	ST 215/75R17.5 LRH	14" (26lb/ft)	10295
102	28	50000	3 X 22,500 lb	ST 215/75R17.5 LRH	14" (26lb/ft)	10495
102	30	50000	3 X 22,500 lb	ST 215/75R17.5 LRH	14" (26lb/ft)	10695

\*WEIGHT OF UNITS ARE APPROXIMATES ONLY AND SUBJECT TO CHANGE DEPENDING ON OPTIONS

## OPTIONAL FEATURES

CODE	DESCRIPTION	CODE	DESCRIPTION
AB3	Third 22,500 lb Axle	T48	Oversized Tongue Mount Toolbox
AR2	Air Ride (2 Axles)	T24	18-Ply Tire Upgrade
AR3	Air Ride (3 Axles)	J56	Hydraulic Jacks
AR2AL1	Air Ride (2 Axles) Air Lift (1 Axle)	D27	Hydraulic Ramps





# TLB MODEL



## Low-Pro Tilt Trailer

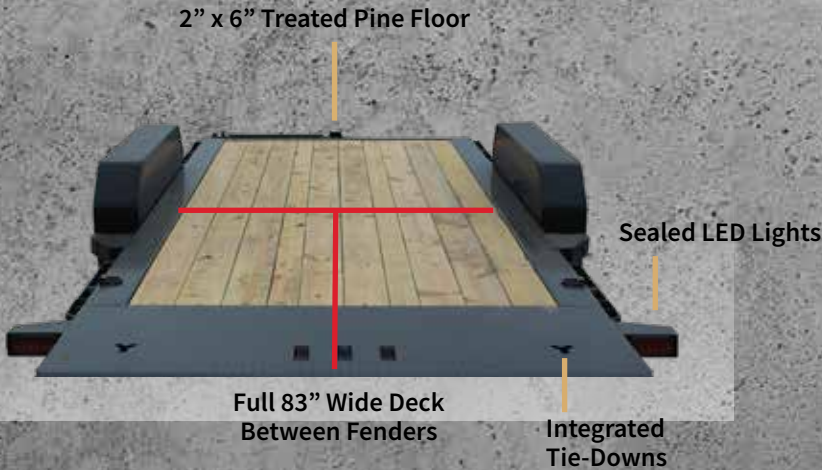

## 2023 TLB

Our 83" wide 14k bumper pull is by far our most popular tilt model. With two 7k axles, tons of standard features and the option between gravity and power tilt, this model is a perfect fit for the contractor or weekend warrior.



(Also Available in Gooseneck)

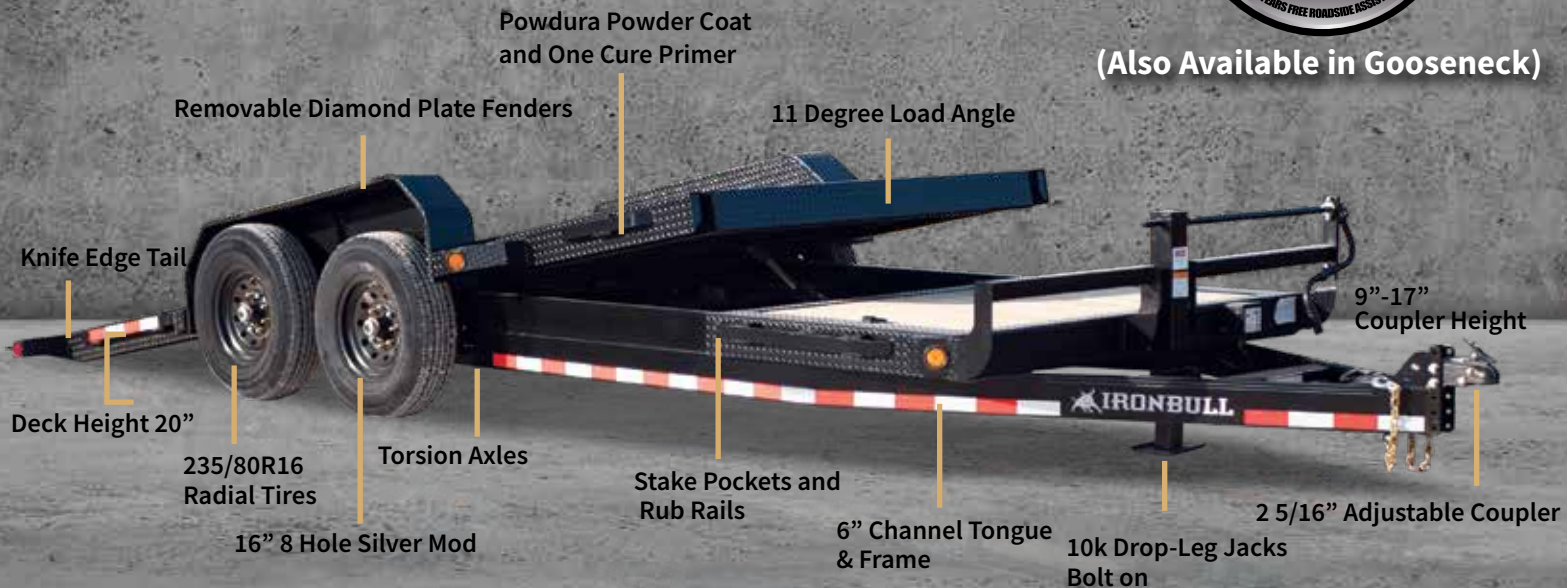

## STANDARD FEATURES

- 6" Channel Tongue (8.2 lbs/ft)
- 2 - 5200 or 7000 Lb Torsion Axles
- 2 5/16" Adjustable Coupler
- 3" Structural Crossmembers
- 20" Deck Height
- 11 Degree Loading Angle
- Knife Edge Tail (1/4" Diamond Plate)
- Removable Diamond Plate Fenders
- Rub Rail and Stake Pockets
- 10k Drop-Leg Jack
- 4 Standard 3" D-Rings

- Radial Tires (sizes on p.37)
- E-Z Lube Hubs
- Black Mod Wheels
- 3" x 10" Cylinder with 1.5" Shaft
- Cambered Torsion Axles
- Multi-leaf Slipper Spring Suspension
- Treated Pine Floor
- Lifetime LED Lighting
- All Lighting DOT Approved
- Molded Sealed Harness with Resistors
- 7-Way Receiver Female Plug with Adapter
- Powdura Powder Coat & One Cure Primer

BUILD A QUOTE ONLINE AT [NORSTARCOMPANY.COM](http://NORSTARCOMPANY.COM)

GRAB A BULL BY THE HORNS



## 2023 BASE SPECS

WIDTH	LENGTH	GVWR	AXLES	TIRE/WHEEL	STATIONARY	WEIGHT
83	16	9990	2 X 5200 lb	225/75R16 6 Hole	0' (Power Tilt Only)	3200
83	18	9990	2 X 5200 lb	225/75R16 6 Hole	2'	3400
83	20	9990	2 X 5200 lb	225/75R16 6 Hole	4'	3500
83	22	9990	2 X 5200 lb	225/75R16 6 Hole	6'	3600
83	18	14000	2 X 7000 lb	235/80R16 8 Hole	2'	3700
83	20	14000	2 X 7000 lb	235/80R16 8 Hole	4'	3800
83	22	14000	2 X 7000 lb	235/80R16 8 Hole	6'	4000
83	24	14000	2 X 7000 lb	235/80R16 8 Hole	8'	4200
83	26	14000	2 X 7000 lb	235/80R16 8 Hole	10'	4400

\*WEIGHT OF UNITS ARE APPROXIMATES ONLY AND SUBJECT TO CHANGE DEPENDING ON OPTIONS

## OPTIONAL FEATURES

CODE	DESCRIPTION	CODE	DESCRIPTION
V58	Power Up/Power Down	E02	Steel Floor (per ft)
A36	Full Deck Tilt (Power Included)	E03	Blackwood Floor
02	102" Wide Deck (83" Between Fenders)	W91	Cold Weather Harness
ET3	Third Torsion Axle (Three Electric Brakes)	T46	Front Tool Box (Gravity Only)
082	Tandem 8k Axles	T06	14-Ply 235/85 Tire Upgrade (ea.)
K21	12" Crossmembers (per ft)	U50	Winch Plate (Floor)

### 2023 TLB Optional Features



102 Wide Deck Available



Blackwood Flooring



Three 7K Axles



Full Power Tilt



Gravity Tilt



Gooseneck Available

5500 FM 38N, BROOKSTON, TX 75421



# TDP14 MODEL



14k Deckover Tilt Pintle Trailer

## 2023 TDP14

Our TDP14 Deckover features an 8" I-Beam tongue and frame. 14k GVWR and dual hydraulic cylinders with optional scissor. The TDP is built to deliver maximum performance and versatility.

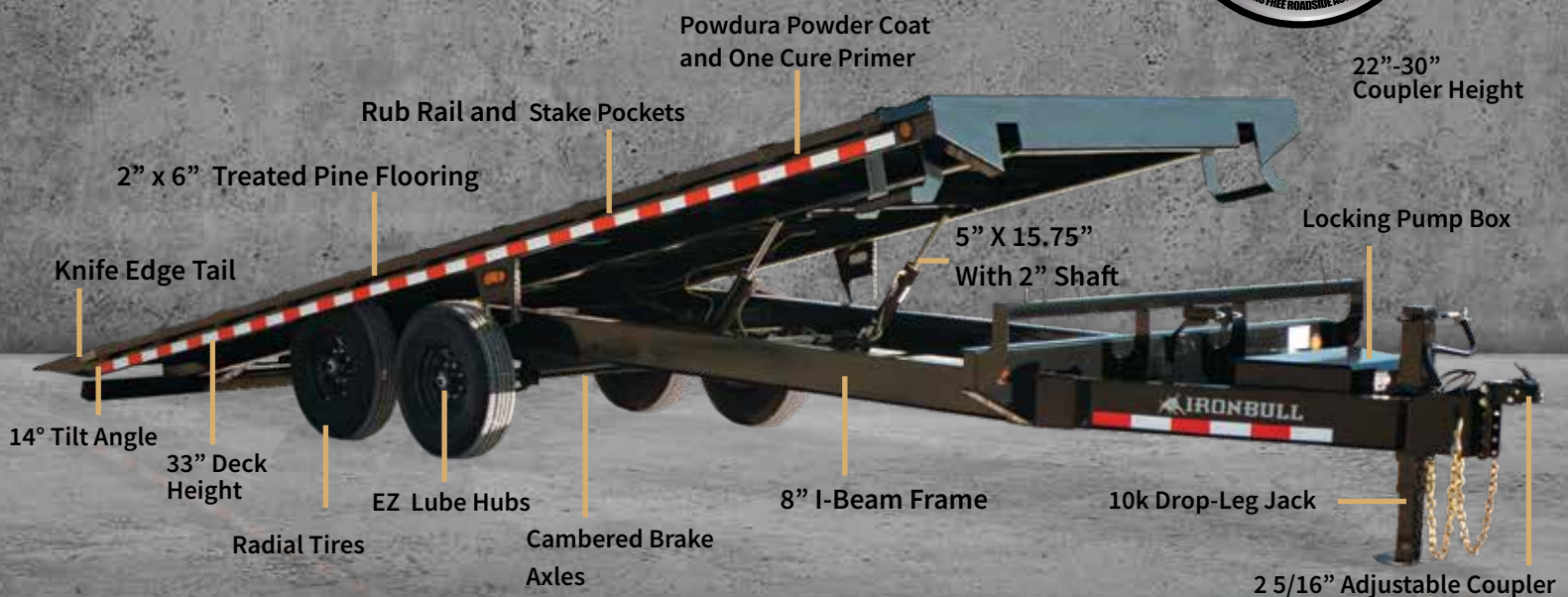
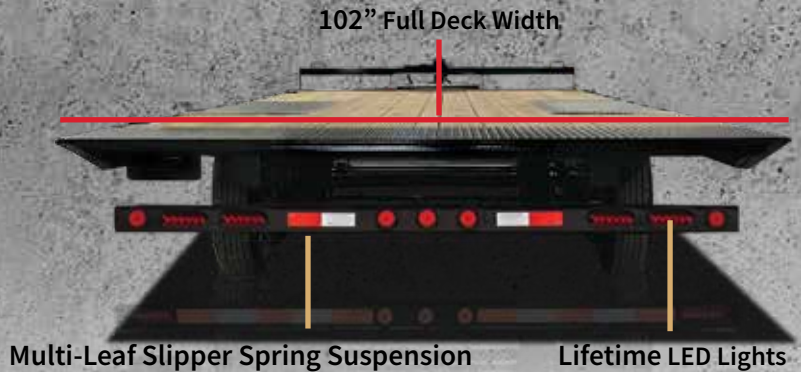

## STANDARD FEATURES

- 8" I-Beam Frame (10 lbs/ft)
- 2 5/16" Adjustable Coupler
- 3" Structural Crossmembers
- 4" Tube Frame Runners
- Rub Rail, Stake Pockets & Pipe Spools
- Cambered Spring Axles
- Multi-leaf Slipper Spring Suspension
- E-Z Lube Hubs
- 2 Electric Brake Axles
- 10k Drop-Leg Jack
- Treated Pine 2" x 6" Floor
- 4 Standard 3" D-Rings
- Black Mod Wheels
- 235/80R16 Radial Tires
- Lifetime LED Lighting
- All Lighting DOT Approved
- Molded Sealed Harness with Resistors
- 7-Way Receiver Female Plug with Adapter
- Powdura Powder Coat & One Cure Primer

BUILD A QUOTE ONLINE AT [NORSTARCOMPANY.COM](http://NORSTARCOMPANY.COM)

GRAB A BULL BY THE HORNS



## 2023 BASE SPECS

WIDTH	LENGTH	GVRW	AXLES	TIRE/WHEEL	FRAME	WEIGHT
102	22	14000	2 X 7000 lb	235/80R16 8 Hole	8" I-Beam	4300
102	24	14000	2 X 7000 lb	235/80R16 8 Hole	8" I-Beam	4800
102	26	14000	2 X 7000 lb	235/80R16 8 Hole	8" I-Beam	5170
102	28	14000	2 X 7000 lb	235/80R16 8 Hole	8" I-Beam	5370
102	30	14000	2 X 7000 lb	235/80R16 8 Hole	8" I-Beam	5680.

\*WEIGHT OF UNITS ARE APPROXIMATES ONLY AND SUBJECT TO CHANGE DEPENDING ON OPTIONS

## OPTIONAL FEATURES

CODE	DESCRIPTION	CODE	DESCRIPTION
ES3	Third Spring Axle (Three Brake Axles)	K21	12" Crossmembers (per ft)
082	Tandem 8k Axles	E01	3" Adjustable Pintle Ring
V54	516 Scissor Hoist	T01	Weld on Spare Tire Mount
E02	Steel Floor (per ft)	R01	Winch Plate 1/2" (in floor)
E03	Blackwood Floor	W91	Cold Weather Harness



Photos may include optional features.



# UTB MODEL



## 14k Deckover Tilt Pintle Trailer

2" Tube Fold-In Gate

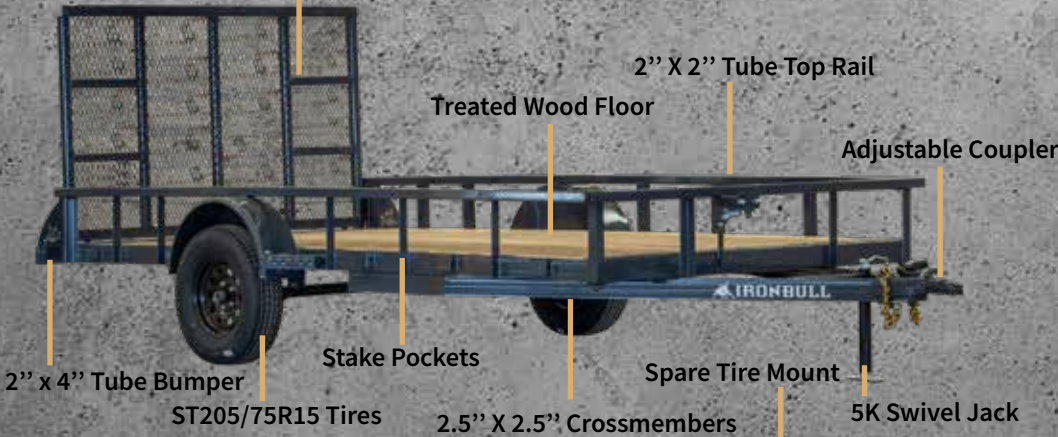

## ALL-NEW UTB

Taking the field by storm is the ALL-NEW Iron Bull UTB. Our beefed up utility trailer packs a serious punch and is available in single or tandem axle configurations with the same heavy duty build that you have come to expect to get from Iron Bull.

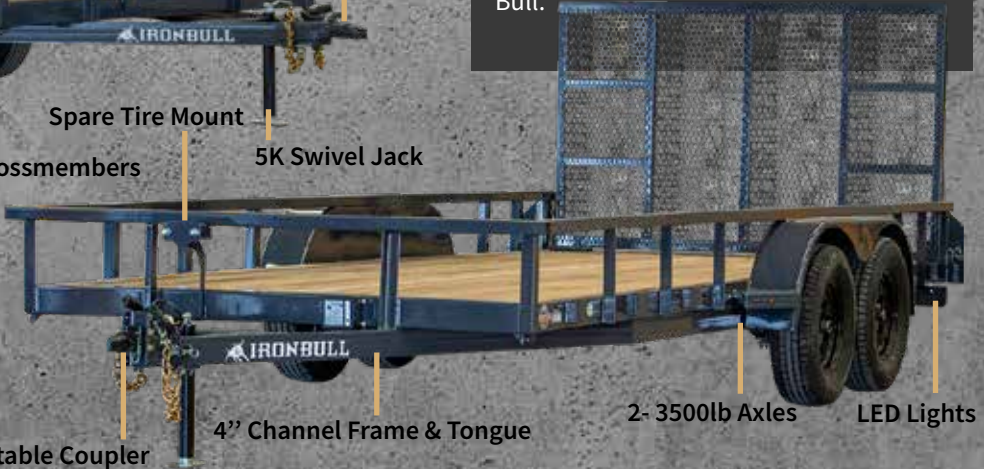

## AVAILABLE SIZES

### Single Axle UTB03

83" X 12'

83" X 14'

### Tandem Axle UTB07

83" X 14'

83" X 16'

83" X 18'



Adjustable Coupler



4' Fold-In Gate

## TANDEM AXLE UTB07 BASE SPECS Lengths- 14, 16 & 18

- 2 - 3500 Lb Axles (1 Elec Brake & 1 Idler)
- Channel 4" X 4.5LBS Frame & Tongue
- Angle 2.5" X 2.5" X 3/16" Crossmembers
- Tube 2" X 4" X 1/8" Rear Bumper
- Straight Deck (Std.)
- Tube Top Rail (Tube 2" X 2" X 1/8")
- 4" Tail Gate w/ Springs (Tube 2" X 2" X 1/8" & Angle 2 1/2" X 2 1/2" X 3/16")
- Self-Retained Gate Pins
- Spring 7/16" wire
- DP Fender Step
- Bumper Pull Adj 7k Coupler
- Jack Swivel Topwind 5k
- Teardrop Tandem Fender
- Treated Wood Floor
- C- Formed Front Bumper (Std.)
- Standard Wire Harness & 3/4" Lights
- Stake Pockets
- Tie Downs
- ST205/75 R15 (D) 8Ply
- Spare Tire Mount
- Grey
- Available 2nd Brake Axle

BUILD A QUOTE ONLINE AT [NORSTARCOMPANY.COM](http://NORSTARCOMPANY.COM)

GRAB A BULL BY THE HORNS





Fully LED Lighting With Fold-In Gate



2" X 2" Top Tube Rail



Tear Drop Tandem Fender



C-Formed Front Bumper

## SINGLE AXLE UTB03 BASE SPECS

- 1 - 3500 Lb Axle (Idler)
- Channel 4" X 4.5LBS Frame & Tongue
- Angle 2.5" X 2.5" X 3/16" Crossmembers
- Tube 2" X 4" X 1/8" Rear Bumper
- Straight Deck (Std.)
- Tube Top Rail (Tube 2" X 2" X 1/8")
- 4" Tail Gate w/ Springs (Tube 2" X 2" X 1/8" & Angle 2 1/2" X 2 1/2" X 3/16")
- Self-Retained Gate Pins
- Spring 7/16" wire
- DP Fender Step
- 2" A-Frame Coupler
- Jack Swivel Topwind 5k
- Teardrop Single Fender
- Treated Wood Floor
- C- Formed Front Bumper (Std.)
- Standard Wire Harness & 3/4" Lights
- Stake Pockets
- Tie Downs
- ST205/75 R15 (D) 8Ply
- Spare Tire Mount
- Grey



## SIDE EXTENSIONS

CODE	DESCRIPTION	CODE	DESCRIPTION
S43505552BK	24" Side Extensions 83" X 12'	S43505553BK	24" Side Extensions 60" X 10'
S43505550BK	24" Side Extensions 83" X 14'	S43505554BK	24" Side Extensions 72" X 10'
S43505551BK	24" Side Extensions 83" X 16'	S43505555BK	24" Side Extensions 72" X 12'



24" Side Extensions 83" X 14'



24" Side Extensions 60" X 10'

## JACKS

CODE	DESCRIPTION	CODE	DESCRIPTION
S43002032BK	Hydraulic 7K Jack Kit	S43002003	7k Jack, Bolt-On
S43002009BK	Dual Hydraulic 12k Jack Kit	S43002002	10k Single Side Pin FDP, FLP, DTB, TDP, ETB Jack
S43002033BK	Single 12k Hydraulic Jack Kit	S43002001	10k Single Side Pin TLB Jack
S43002030BK	Dual 2-Speed Front Pin Jack Kit	300200015	Jack Handle
S43002005BK	10K Dual RH Jack	S43002004BK	10k Dual LH Jack



7k Hydraulic Jack



12k Hydraulic Jack



Cold Weather Harness

## COLD WEATHER WIRING UPGRADES

CODE	DESCRIPTION	CODE	DESCRIPTION
301300081	Bumper Pull Dump Trailers	301300085	Gooseneck Flat Bed Trailers
301300083	Gooseneck Dump Trailers	301300089	Bumper Pull Flat Bed Trailers

DEALER PRICING AVAILABLE AT [NORSTARPARTS.COM](http://NORSTARPARTS.COM)



## HYDRAULICS

CODE	DESCRIPTION	CODE	DESCRIPTION
301400031	2-way Hydraulic Pump	301300111	KTI Wired 4 Button Remote
301400034	4-way Hydraulic Pump	301300093	KTI 15' Remote Extension Cable
301300090	KTI 2 Button Wireless Remote	301300016	5amp Charger
301300101	KTI 4 Button Wireless Remote	301300131	Boss 10amp Super Charger
301300103	KTI Wired 2 Button Remote	301300132	Solar Panel Charger

## ADD-ONS

CODE	DESCRIPTION	CODE	DESCRIPTION
300100003	Coupler 2-5/16"	300200011	Rear Stabilizer Jack for Equipment Trailers
300100002	Coupler 2"	S43002510	Rear Support Stands for Dump Trailers
300400003	Mud Flap Iron Bull Tandem Axle Dual Wheel	S43006001BK	Bolt On/Weld On Spare Mount
300400004	Mud Flap Iron Bull Tandem Axle Single Wheel	S43006003BK	Front Bumper Spare Mount
250170038	Winch Plate	S43006002BK	Stake Pocket Spare Tire Mount

## TOOLBOXES

CODE	DESCRIPTION	CODE	DESCRIPTION
S43004004BK	Butterfly Toolbox	S43610400BK	16H x 20D x 30L Side Undermount Toolbox
S43004015BK	Secondary Tongue Mount Toolbox	S43004027BK	Gooseneck Style Top Open Angled Toolbox
S43004006GY	DWB Large Tongue Mount Toolbox	S43004007GY	EWB Large Tongue Mount Toolbox
S43004034BK	DTB Large Tongue Mount Toolbox		



## TIRES & WHEELS (available in silver mod as well)

CODE	DESCRIPTION	CODE	DESCRIPTION
300300002	205/75R15 8ply Black Mod	300300014	235/85R16 14ply Black Mod
300300003	225/75R15 8ply Black Mod	300300011	235/85R16 14ply Dual Black Mod
300300001	235/80R16 10ply Black Mod	300300012	215/75R17.5 16ply Dual Black Mod
300300000	235/80R16 10ply Dual Black Mod	300300019	235/75R17.5 16ply Super Single