

# Freedom

5 COLOURS

3 SIZES

2 SURFACES

Freedom is inspired by Hauteville stone; known for its hardness and strength, it is used in buildings around the world, including the base of the Statue of Liberty and the Empire State Building in New York.

CERAMICHE PIEMME

FLOOR AND MORE

Freedom è liberamente ispirata alla pietra di Hauteville; nota per le sue caratteristiche di durezza e resistenza, viene usata nelle costruzioni di tutto il mondo, fra cui il basamento della statua della Libertà e l'Empire State Building di New York.

Freedom ist frei am Hauteville-Stein inspiriert, der für seine Härte und Beständigkeit bekannt ist. Er dient in aller Welt als Baustoff, etwa als Sockel der Freiheitsstatue und für das Empire State Building in New York.

Freedom s'inspire librement de la pierre de Hauteville, très appréciée pour sa dureté et pour sa résistance. On la retrouve d'ailleurs un peu partout dans le monde, par exemple sur le socle de la Statue de la Liberté et sur l'Empire State Building de New York.

## Freedom



Spazi Residenziali  
Residential Spaces

P. 5

Spazi Pubblici  
Public Areas

P. 19

Informazioni Tecniche  
Technical Information

P. 37

E' una roccia con una tessitura fine che può presentare numerose variazioni di tonalità. Proprio questa particolare caratteristica è stata sottolineata dai ricercatori Piemme che ne hanno colto il grande potenziale estetico, per reinterpretarla enfatizzando la naturale alternanza delle tonalità di fondo e delle sottili venature ottenendo una pietra di grande carattere e gradevole al tempo stesso.

It is a rock with a fine texture which can feature numerous shade variations. This particular characteristic has been underlined by Piemme researchers who have grasped its great aesthetic potential, reinterpreting it by emphasizing the natural alternation of the background shades and the thin veins to obtain a stone at the same time of great character and nice to look at.

Die Struktur des Steins ist fein und kann zahlreiche Farbtonvarianten aufweisen. Gerade dieses Merkmal wurde von den Piemme-Produktentwicklern hervorgehoben, die das große ästhetische Potenzial des Gesteins erkannt und neuinterpretiert haben: Sie haben den natürlichen Wechsel zwischen der Grundfarbe und jenen der feinen Äderungen verstärkt und eine Steinoptik erzielt, die charaktvoll und gefällig zugleich ist.

Cette roche de fine texture peut présenter d'innombrables variantes de teintes. C'est précisément cette caractéristique que les chercheurs Piemme ont voulu mettre en valeur pour exalter tout le potentiel esthétique de la pierre et pour l'interpréter en rehaussant la variation naturelle de ses tonalités de fond et ses veines fines. Le résultat obtenu est une pierre de caractère, très agréable à regarder.

# Spazi Residenziali

Residential Spaces  
Wohnanlagen  
Espaces Résidentiels



COLORI / COLOURS

AMBIENTI / AMBIENT

PAGINA / PAGE

Sand	Entrance	7
Sand	Bedroom	8
Grey	Kitchen	10
White / Grey	Bathroom	14

Freedom  
Residential Spaces

5

## Sand

Freedom is characterised by natural shades and thin veins with nuances that make possible the creation of warm and welcoming spaces.

Natürliche Farben und feine Äderungen prägen Freedom, dessen warme Nuancen Räume mit behaglicher Atmosphäre schaffen.

Freedom se distingue par ses tonalités naturelles et par ses veines fines. Ses nuances permettent de mettre en scène une décoration chaleureuse et accueillante.

Tonalità naturali e sottili venature caratterizzano Freedom, le cui nuances offrono l'opportunità di creare spazi caldi ed accoglienti.

30×60 - 12"×24" Naturale Rettificato

30×30 - 12"×12" Mosaico Craft Warm

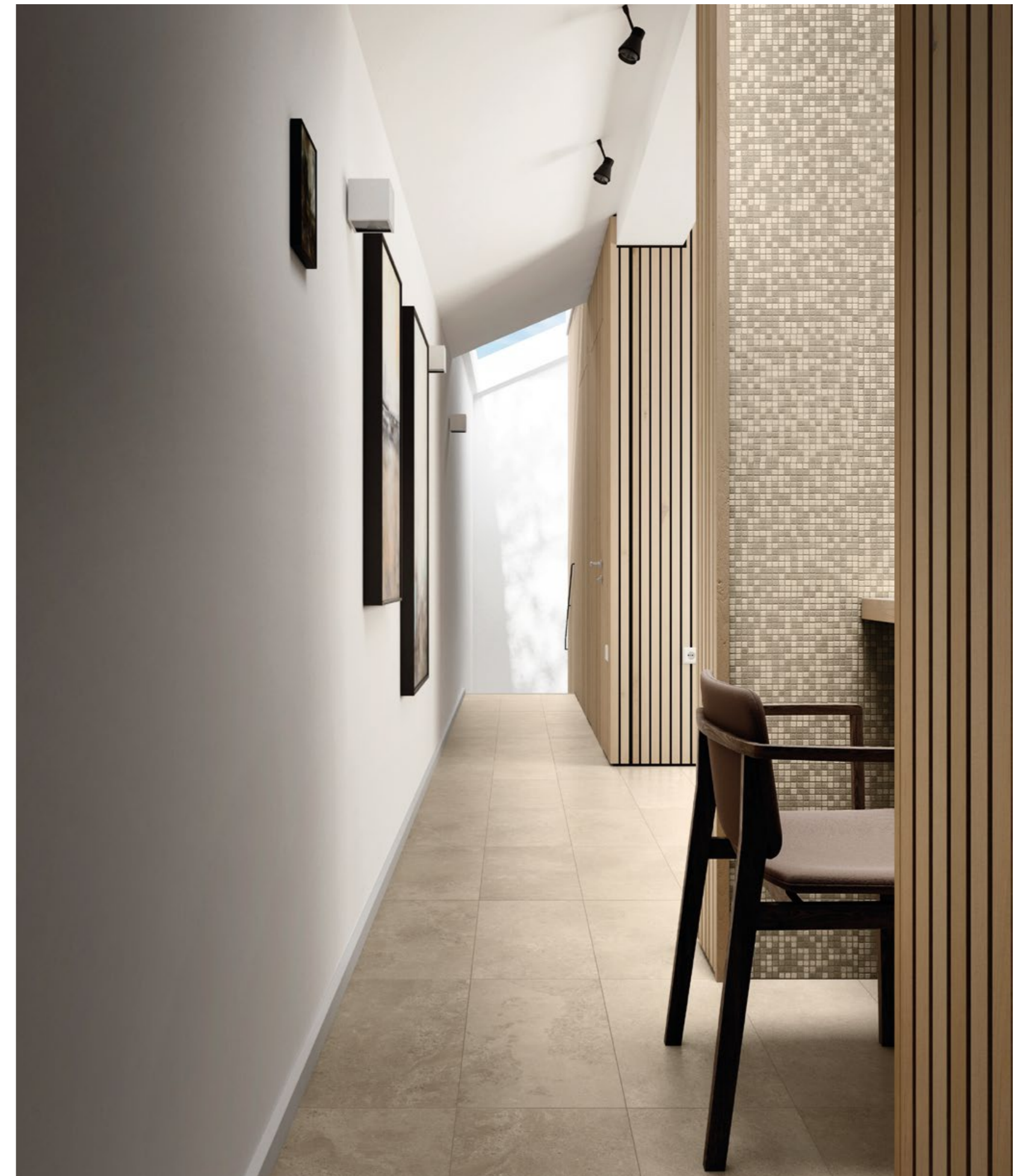

Freedom  
Residential Spaces











## White

The horizontal and vertical surfaces offer the chance of personalizing interiors, reflecting the personality of those who live in them. The mosaic wall proposals provide further ideas for coordinated spaces..

Waagrecht und senkrecht verlegte Flächen bieten Gelegenheit zur Personalisierung des Raums und spiegeln den Charakter seiner Bewohner wider. Mosaik-Wandverkleidungen bieten weitere Anregungen für aufeinander abgestimmte Innenräume.

Les surfaces horizontales et verticales deviennent un outil pour personnaliser l'espace, en exprimant le caractère de ses occupants. Les mosaïques murales sont des accessoires pour assortir les revêtements intérieurs.

Le superfici orizzontali e verticali divengono occasione per personalizzare lo spazio, rispecchiando il carattere di chi lo vive. Le proposte di rivestimento a mosaico offrono ulteriori spunti per interni coordinati.

30x30 - 12"x12" Mosaico Naturale Rettificato

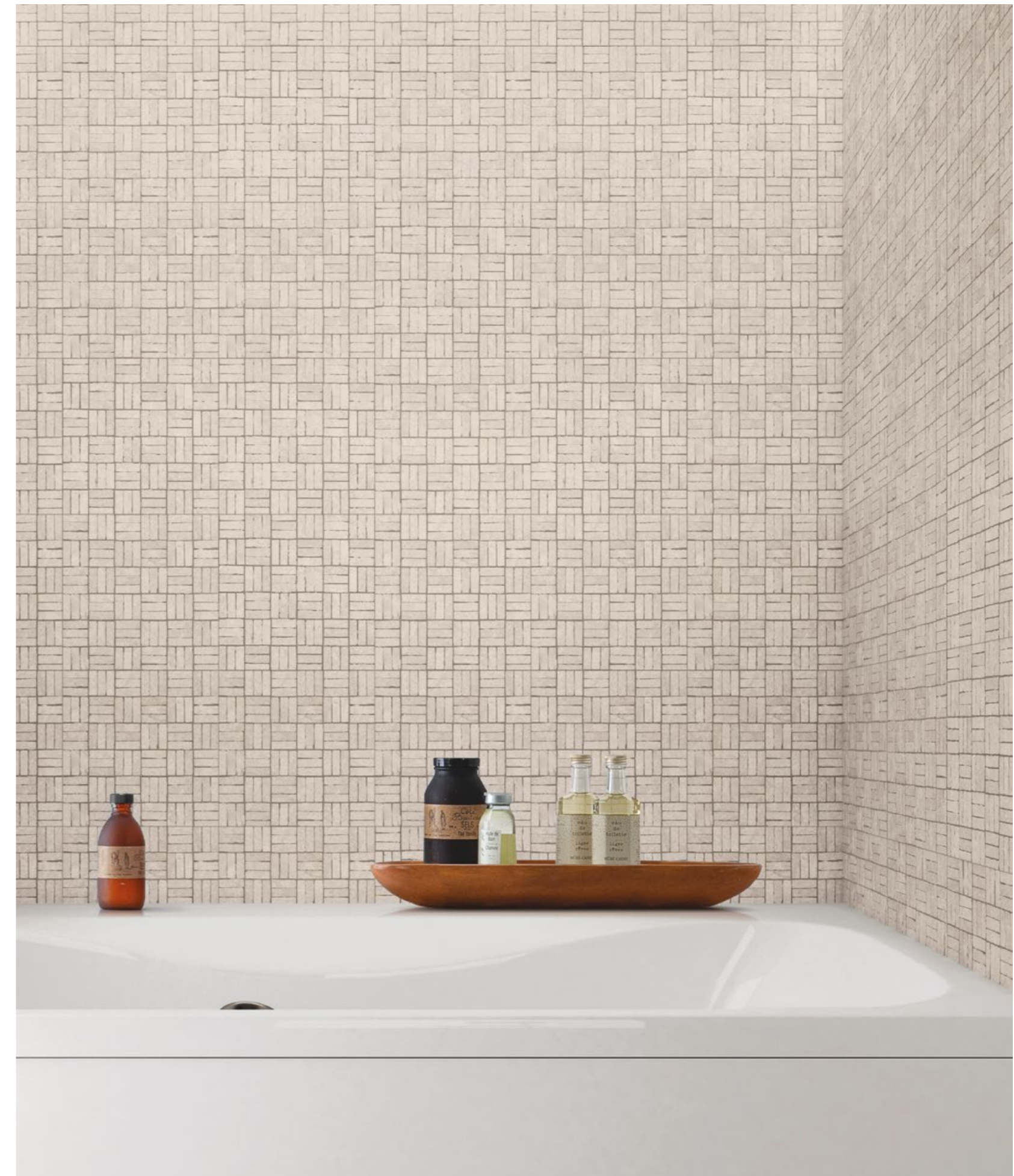

Freedom  
Residential Spaces

# Spazi Pubblici

Public Areas  
Öffentliche Räumlichkeiten  
Espaces Publics



COLORI / COLOURS	AMBIENTI / AMBIENT	PAGINA / PAGE
Nut	Hotel	20
Sand	Lobby	25
White	Café	28
Antracite / White	Hotel Room	31



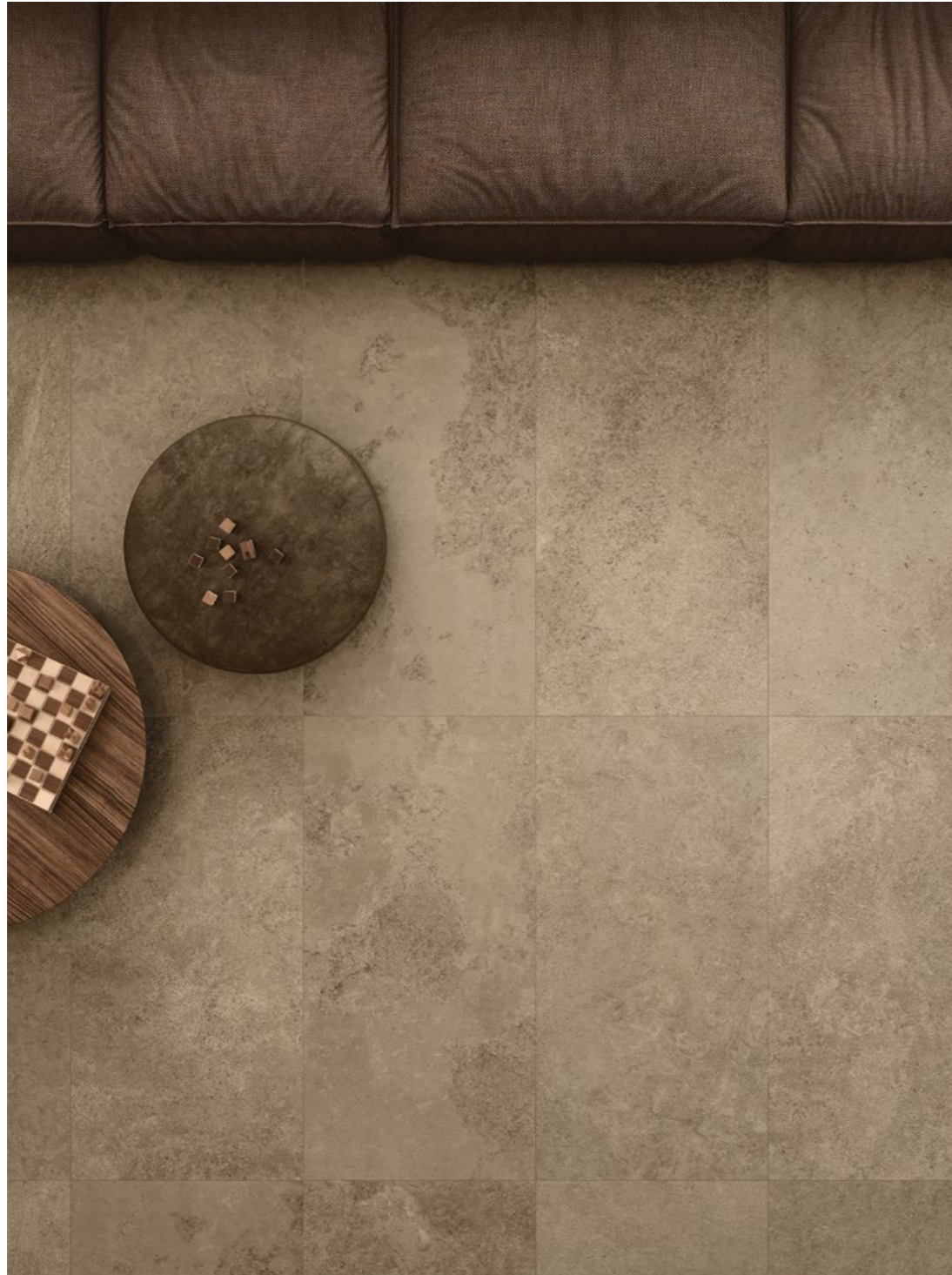

## Sand

A stone of great aesthetic potential, produced to create refined atmospheres and design environments with a sober and elegant character.

Ein Stein von hohem ästhetischen Potenzial, dazu geschaffen, eine edle Atmosphäre zu erzeugen und Räume von schlicht-elegantem Charakter zu gestalten.

Une pierre possédant un grand potentiel esthétique, faite pour créer des atmosphères raffinées et pour donner aux espaces sobriété et élégance.

60×119,5 - 24"×47½" Naturale Rettificato

Una pietra dal grande potenziale estetico, nata per creare atmosfere raffinate e progettare ambienti dal carattere sobrio ed elegante.









## White

Freedom offers a range able to cater to numerous requirements in the fields of residential housing, public sector and commercial surfaces, right up to outdoor wall coverings.

Freedom umfasst ein Sortiment für verschiedenste Anwendungen: im Wohnungsbau, in öffentlichen und gewerblichen Bereichen, bis hin zu Außenwandverkleidungen.

Freedom propose une série en mesure de répondre à des nombreuses exigences, non seulement dans les applications résidentielles, publiques et commerciales, mais également dans les projets de revêtements extérieurs.

60x60 - 24"x24" Naturale Rettificato

Freedom offre una gamma in grado di rispondere a molteplici esigenze, nell'ambito residenziale, nel settore pubblico e commerciale, fino ai rivestimenti per esterni.

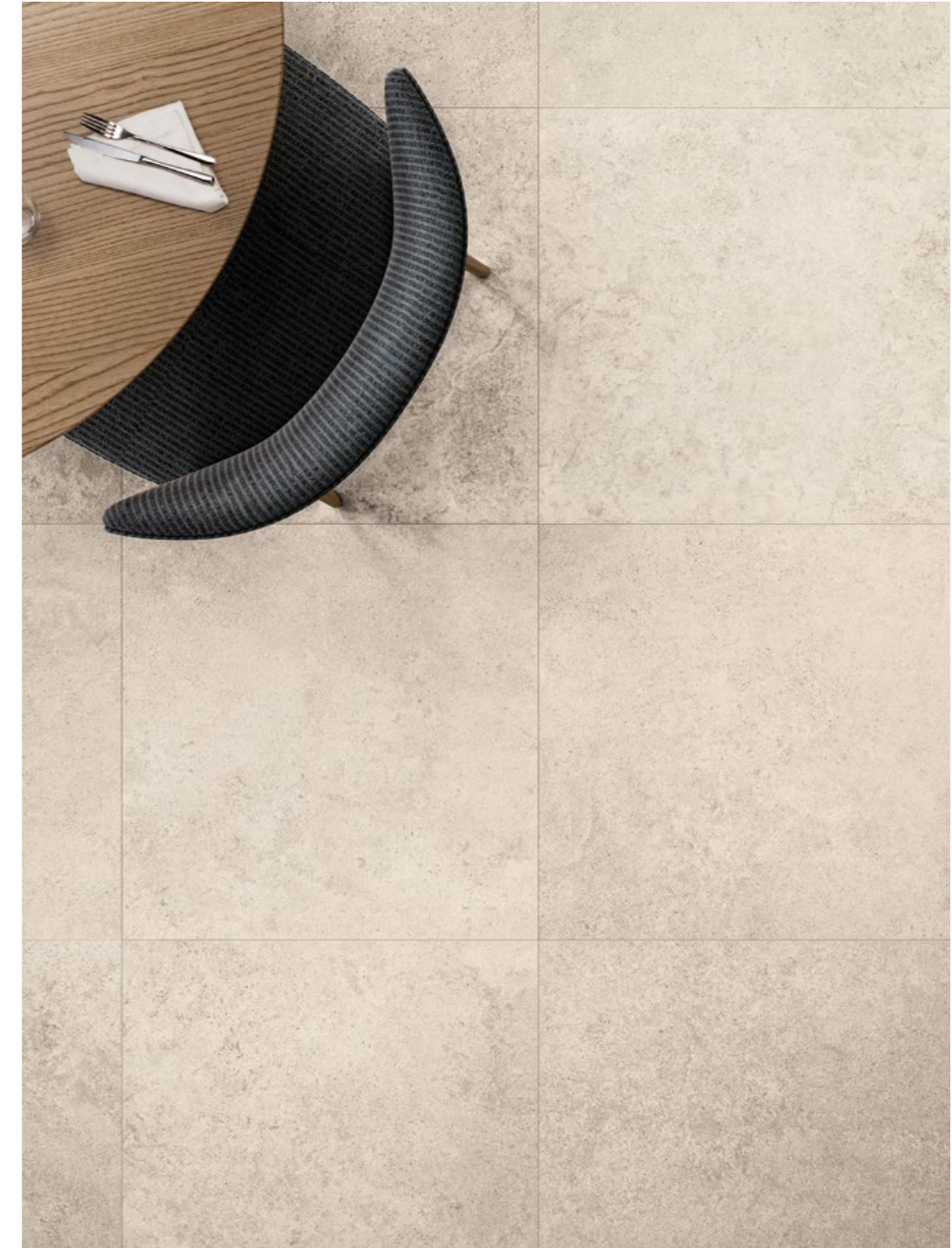





# Informazioni Tecniche

5

Colori  
Colours  
Farben  
Couleurs

White



Sand



Nut



Grey



Antracite

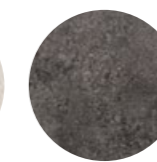

3

Formati  
Sizes  
Formate  
Formats

\*60×119,5  
24"×47½"



60×60  
24"×24"



30×60  
12"×24"



\*formato modulare con 60x60 e 30x60 / modular size, can be matched with 60x60 and 30x60 size /  
modulares, spricht mit dem Format 60x60 und 30x60 kombinierbares Format / format modulaire pouvant être coordonné au format 60x60 et 30x60

1

Spessore  
Thickness  
Stärke  
Epaisseur

±9,5

2

Superfici  
Surfaces  
Oberflächen  
Surfaces

Naturale Antislip

3

Strutture 3D  
3D structures  
Strukturen  
Décorations en relief

Polygons



Shape



Blocks



i

Effetto Pietra  
Stone Look  
Natursteinoptik  
Effet Pierre

Rivestimento  
Wall Tiles  
Wandfliesen  
Revêtement

Pavimento  
Floor Tiles  
Bodenfliesen  
Sol

Gres fine porcellanato  
Fine porcelain stoneware  
Feinsteinzeug  
Grès cérame fin

Tecnologia digitale  
Digital technology  
Digital technologie  
Technologie numérique



# White



± 9,5

\*60x119,5 - 24"x47 1/2"  
**02184** | Freedom White Nat/Ret



± 9,5

60x60 - 24"x24"  
**02173** | Freedom White Nat/Ret



± 9,5

30x60 - 12"x24"  
**02162** | Freedom White Nat/Ret

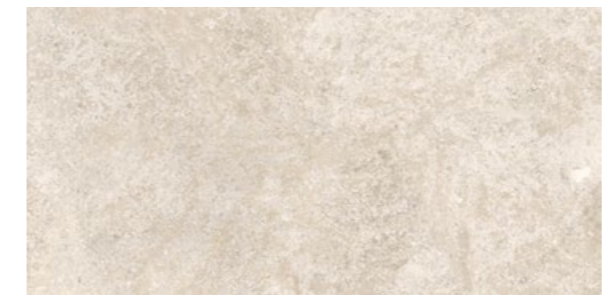

± 9,5

\*60x119,5 - 24"x47 1/2"  
**02189** | Freedom White Antislip/Ret



± 9,5

60x60 - 24"x24"  
**02178** | Freedom White Shape Nat/Ret



± 9,5

30x60 - 12"x24"  
**02167** | Freedom White Polygons Nat/Ret



± 9,5

\*60x119,5 - 24"x47 1/2"  
**02195** | Freedom White Blocks Nat/Ret



± 9,5

60x60 - 24"x24"  
**02444** | Freedom Shape Shine Cold Nat/Ret



± 9,5

30x60 - 12"x24"  
**02447** | Freedom Batik Mix Cold Ret

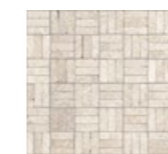

± 9,5

30x30 - 12"x12"  
**02385** | Freedom White Mosaico Nat/Ret



± 9,5

30x30 - 12"x12"  
**02451** | Freedom Mosaico Craft Cold



30x60 - 12"x24"  
**02447** | Freedom Batik Mix Cold Ret

\* formato modulare con 60x60 e 30x60 / modular size, can be matched with 60x60 and 30x60 size /  
modulares, spricht mit dem Format 60x60 und 30x60 kombinierbares Format / format modulaire pouvant être coordonné au format 60x60 et 30x60

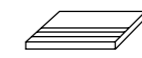
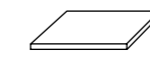
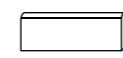



# Sand

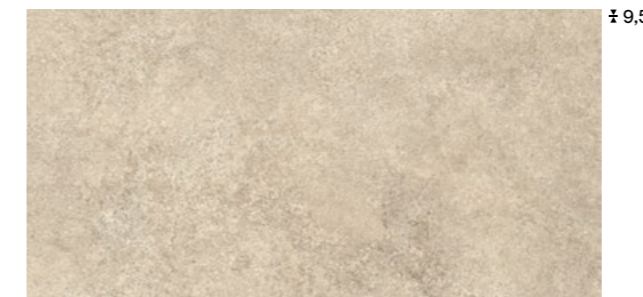

± 9,5

\*60x119,5 - 24"x47 1/2"  
**02185** | Freedom Sand Nat/Ret

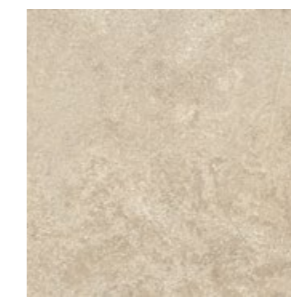

± 9,5

60x60 - 24"x24"  
**02174** | Freedom Sand Nat/Ret

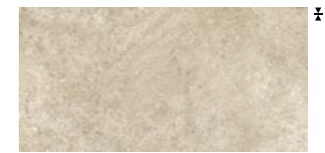

± 9,5

30x60 - 12"x24"  
**02163** | Freedom Sand Nat/Ret

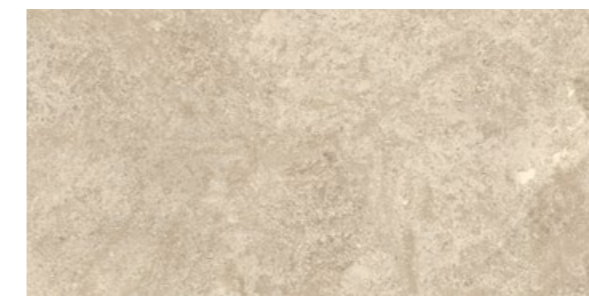

± 9,5

\*60x119,5 - 24"x47 1/2"  
**02191** | Freedom Sand Antislip/Ret



± 9,5

60x60 - 24"x24"  
**02179** | Freedom Sand Shape Nat/Ret



± 9,5

30x60 - 12"x24"  
**02168** | Freedom Sand Polygons Nat/Ret

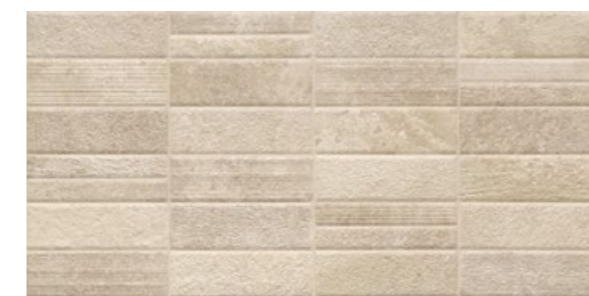

± 9,5

\*60x119,5 - 24"x47 1/2"  
**02196** | Freedom Sand Blocks Nat/Ret



± 9,5

60x60 - 24"x24"  
**02445** | Freedom Shape Shine Warm Nat/Ret



± 9,5

30x60 - 12"x24"  
**02448** | Freedom Batik Mix Warm Ret

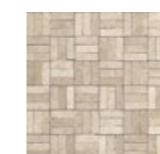

± 9,5

30x30 - 12"x12"  
**02386** | Freedom Sand Mosaico Nat/Ret



± 9,5

30x30 - 12"x12"  
**02452** | Freedom Mosaico Craft Warm



30x60 - 12"x24"  
**02448** | Freedom Batik Mix Warm Ret

\* formato modulare con 60x60 e 30x60 / modular size, can be matched with 60x60 and 30x60 size /  
modulares, spricht mit dem Format 60x60 und 30x60 kombinierbares Format / format modulaire pouvant être coordonné au format 60x60 et 30x60

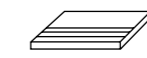
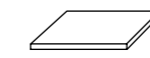
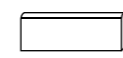



# Nut



± 9,5

\*60×119,5 - 24"×47 1/2"  
**02186** | Freedom Nut Nat/Ret



± 9,5

60×60 - 24"×24"  
**02175** | Freedom Nut Nat/Ret



± 9,5

30×60 - 12"×24"  
**02164** | Freedom Nut Nat/Ret



± 9,5

\*60×119,5 - 24"×47 1/2"  
**02192** | Freedom Nut Antislip/Ret



± 9,5

60×60 - 24"×24"  
**02181** | Freedom Nut Shape Nat/Ret



± 9,5

30×60 - 12"×24"  
**02169** | Freedom Nut Polygons Nat/Ret



± 9,5

\*60×119,5 - 24"×47 1/2"  
**02197** | Freedom Nut Blocks Nat/Ret



± 9,5

60×60 - 24"×24"  
**02445** | Freedom Shape Shine Warm Nat/Ret



± 9,5

30×60 - 12"×24"  
**02448** | Freedom Batik Mix Warm Ret

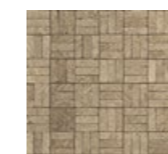

± 9,5

30×30 - 12"×12"  
**02387** | Freedom Nut Mosaico Nat/Ret



± 9,5

30×30 - 12"×12"  
**02452** | Freedom Mosaico Craft Warm

\* formato modulare con 60x60 e 30x60 / modular size, can be matched with 60x60 and 30x60 size /  
modulares, spricht mit dem Format 60x60 und 30x60 kombinierbares Format / format modulaire pouvant être coordonné au format 60x60 et 30x60

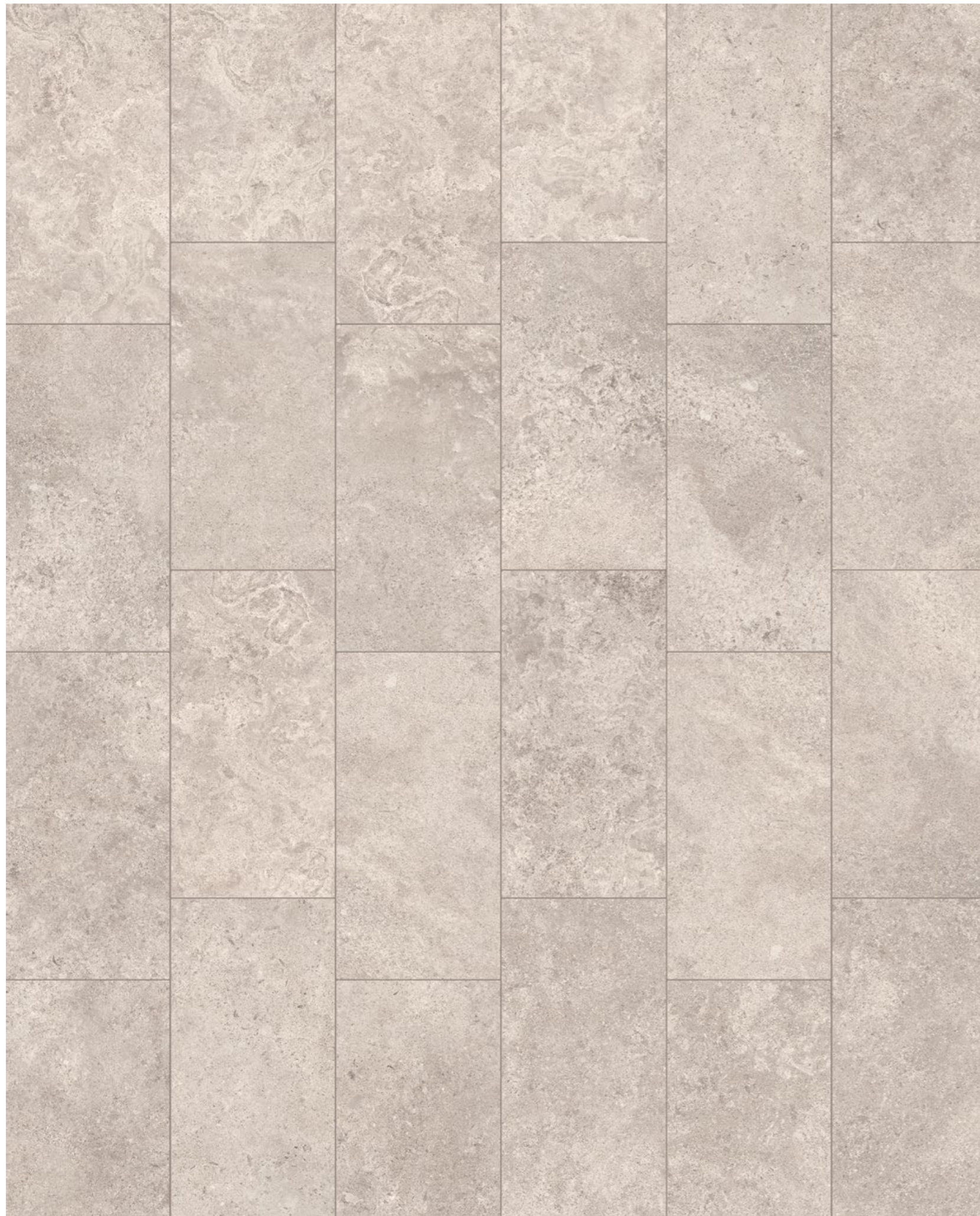

# Grey



± 9,5

\*60×119,5 - 24"×47 1/2"  
**02187** | Freedom Grey Nat/Ret



± 9,5

60×60 - 24"×24"  
**02176** | Freedom Grey Nat/Ret



± 9,5

30×60 - 12"×24"  
**02165** | Freedom Grey Nat/Ret



± 9,5

\*60×119,5 - 24"×47 1/2"  
**02193** | Freedom Grey Antislip/Ret



± 9,5

60×60 - 24"×24"  
**02182** | Freedom Grey Shape Nat/Ret



± 9,5

30×60 - 12"×24"  
**02171** | Freedom Grey Polygons Nat/Ret



± 9,5

\*60×119,5 - 24"×47 1/2"  
**02198** | Freedom Grey Blocks Nat/Ret



± 9,5

60×60 - 24"×24"  
**02444** | Freedom Shape Shine Cold Nat/Ret



± 9,5

30×60 - 12"×24"  
**02447** | Freedom Batik Mix Cold Ret



± 9,5

30×30 - 12"×12"  
**02388** | Freedom Grey Mosaico Nat/Ret



± 9,5

30×30 - 12"×12"  
**02451** | Freedom Mosaico Craft Cold



30×60 - 12"×24"  
**02447** | Freedom Batik Mix Cold Ret

\* formato modulare con 60x60 e 30x60 / modular size, can be matched with 60x60 and 30x60 size /  
modulares, spricht mit dem Format 60x60 und 30x60 kombinierbares Format / format modulaire pouvant être coordonné au format 60x60 et 30x60





# Antracite



± 9,5

\*60×119,5 - 24"×47½"

**02188** | Freedom Antracite Nat/Ret

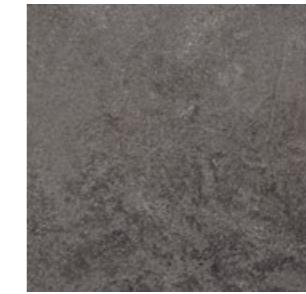

± 9,5

60×60 - 24"×24"

**02177** | Freedom Antracite Nat/Ret



± 9,5

30×60 - 12"×24"

**02166** | Freedom Antracite Nat/Ret



± 9,5

\*60×119,5 - 24"×47½"

**02194** | Freedom Antracite Antislip/Ret

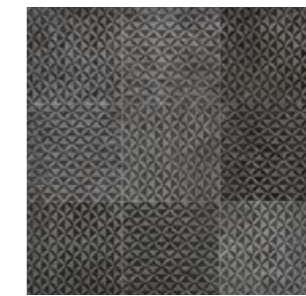

± 9,5

60×60 - 24"×24"

**02183** | Freedom Antracite Shape Nat/Ret



± 9,5

30×60 - 12"×24"

**02172** | Freedom Antracite Polygons Nat/Ret



± 9,5

\*60×119,5 - 24"×47½"

**02199** | Freedom Antracite Blocks Nat/Ret

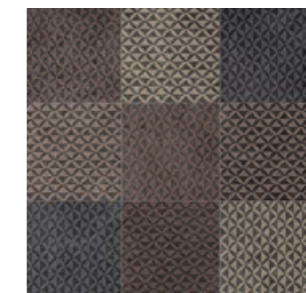

± 9,5

60×60 - 24"×24"

**02446** | Freedom Shape Shine Mix Nat/Ret

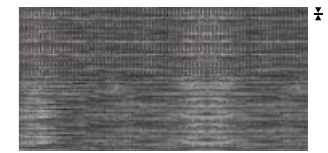

± 9,5

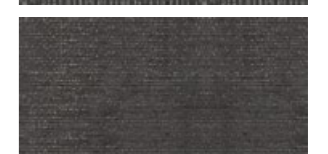

30×60 - 12"×24"

**02449** | Freedom Batik Mix Dark Ret



± 9,5

30×30 - 12"×12"

**02389** | Freedom Antracite Mosaico Nat/Ret

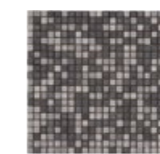

± 9,5

30×30 - 12"×12"

**02495** | Freedom Mosaico Craft Dark











\* formato modulare con 60x60 e 30x60 / modular size, can be matched with 60x60 and 30x60 size /  
modulares, spricht mit dem Format 60x60 und 30x60 kombinierbares Format / format modulaire pouvant être coordonné au format 60x60 et 30x60

# Fasce di Prezzo

Price range  
Preisgruppe  
Niveau de prix

■ Fascia prezzo al metro quadro  
Square meter price range  
Quadratmeter preisgruppe  
Niveau de prix au mètre carré

▲ Fascia prezzo al pezzo  
Price range per piece  
Stück preisgruppe  
Niveau de prix à la piece

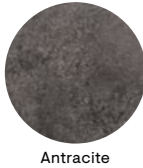











Formati Sizes	  			Din 51130	Din 51097	Dcof						
	60x119,5 - 24x47 1/2"	60x60 - 24x24"	30x60 - 12x24"									
	± 9,5	± 9,5	± 9,5									
 White	Nat/Ret	02184 <b>740</b>	02173 <b>550</b>	02162 <b>500</b>	V3	R10	A+B	>0.42	 Blocks 60x119,5 - 24x47 1/2"	 Shape 60x60 - 24x24"	 Shape Shine 60x60 - 24x24"	 Polygons 30x60 - 12x24"
	Antislip/Ret	02189 <b>750</b>				R11	A+B+C	>0.42	± 9,5	± 9,5	± 9,5	± 9,5
 Sand	Nat/Ret	02185 <b>740</b>	02174 <b>550</b>	02163 <b>500</b>	V3	R10	A+B	>0.42	02195 <b>790</b>	02178 <b>680</b>	02444 <b>790</b>	02167 <b>560</b>
	Antislip/Ret	02191 <b>750</b>				R11	A+B+C	>0.42				
 Nut	Nat/Ret	02186 <b>740</b>	02175 <b>550</b>	02164 <b>500</b>	V3	R10	A+B	>0.42	02196 <b>790</b>	02179 <b>680</b>	02445 <b>790</b>	02168 <b>560</b>
	Antislip/Ret	02192 <b>750</b>				R11	A+B+C	>0.42				
 Grey	Nat/Ret	02187 <b>740</b>	02176 <b>550</b>	02165 <b>500</b>	V3	R10	A+B	>0.42	02197 <b>790</b>	02181 <b>680</b>	02445 <b>790</b>	02169 <b>560</b>
	Antislip/Ret	02193 <b>750</b>				R11	A+B+C	>0.42				
 Antracite	Nat/Ret	02188 <b>740</b>	02177 <b>550</b>	02166 <b>500</b>	V3	R10	A+B	>0.42	02198 <b>790</b>	02182 <b>680</b>	02444 <b>790</b>	02171 <b>560</b>
	Antislip/Ret	02194 <b>750</b>				R11	A+B+C	>0.42				
									02199 <b>790</b>	02183 <b>680</b>	02446 <b>790</b>	02172 <b>560</b>

# Fasce di Prezzo

Price range  
Preisgruppe  
Niveau de prix







■ Fascia prezzo al metro quadro  
Square meter price range  
Quadratmeter preisgruppe  
Niveau de prix au mètre carré

▲ Fascia prezzo al pezzo  
Price range per piece  
Stück preisgruppe  
Niveau de prix à la piece

Formati Sizes	  			   				
	Batik Mix 30x60 - 12x24"	Mosaico 30x30 - 12x12"	Mosaico Craft 30x30 - 12x12"	Gradino 30x119,5 - 12x47 1/2"	Gradino 30x60 - 12x24"	Battiscopa 6,5x119,5 - 2 1/2x47 1/2"	Battiscopa 8x60 - 3 1/2x24"	
	± 9,5	± 9,5	± 9,5	± 9,5	± 9,5	± 9,5	± 9,5	
 White	Nat/Ret	02447 <b>430</b>	02385 <b>160</b>	02451 <b>450</b>	02380 <b>710</b>	02375 <b>200</b>	02369 <b>130</b>	02364 <b>60</b>
 Sand	Nat/Ret	02448 <b>430</b>	02386 <b>160</b>	02452 <b>450</b>	02381 <b>710</b>	02376 <b>200</b>	02371 <b>130</b>	02365 <b>60</b>
 Nut	Nat/Ret	02448 <b>430</b>	02387 <b>160</b>	02452 <b>450</b>	02382 <b>710</b>	02377 <b>200</b>	02372 <b>130</b>	02366 <b>60</b>
 Grey	Nat/Ret	02447 <b>430</b>	02388 <b>160</b>	02451 <b>450</b>	02383 <b>710</b>	02378 <b>200</b>	02373 <b>130</b>	02367 <b>60</b>
 Antracite	Nat/Ret	02449 <b>430</b>	02389 <b>160</b>	02495 <b>450</b>	02384 <b>710</b>	02379 <b>200</b>	02374 <b>130</b>	02368 <b>60</b>

# Imballi

Packing  
Verpackung  
Emballage

Formati Sizes		± MM	 Pezzi Scatola Pieces/Box Stck/Karton Carreaux/Boîte	 Mq/Scatola Sqmt/Box Qm/Karton M2/Boîte	 Kg/Scatola Kgs/Box Kg/Karton Kg/Boîte	 Scatole/Paletta Boxes/Pallet Karton/Palette Boîte/Palette	 Mq/Paletta Sqmt/Pallet Qm/Pallet M2/Palette	 Kg/Paletta Kgs/Pallet Kg/Pallet Kg/Palette	 Formato Paletta Size Pallet Format Pallet Dim. Palette
60×119,5 (24"×47½") Nat/Ret	P	9,5	2	1,434	31,00	30	43,02	930	120x80x75
60×119,5 (24"×47½") Antislip Ret	P	9,5	2	1,434	31,00	30	43,02	930	120x80x75
60×119,5 (24"×47½") Blocks Nat/Ret	P	9,5	2	1,434	31,00	30	43,02	930	120x80x75
60×60 (24"×24") Nat/Ret	P	9,5	3	1,080	21,50	40	43,20	860	120x80x75
30×60 (12"×24") Nat/Ret	P	9,5	6	1,080	21,50	48	51,84	1032	120x80x75
60×60 (24"×24") Shape Nat/Ret	P	9,5	3	1,080	21,50	40	43,20	860	120x80x75
60×60 (24"×24") Shape Shine Nat/Ret	P	9,5	3	1,080	21,50	40	43,20	860	120x80x75
30×60 (12"×24") Polygons Nat/Ret	P	9,5	6	1,080	21,50	40	43,20	860	120x80x75
30×60 (12"×24") Batik Mix Ret	P	9,5	3	0,540	11,00	51	5,94	561	120x80x75
30×30 (12"×12") Mosaico Nat/Ret	P	9,5	5	0,450	8,50	60	-	-	-
30×30 (12"×12") Mosaico Craft	P	9,5	5	0,450	9,00	60	-	-	-

## Pezzi Speciali / Special Pieces

30×119,5 (12"×47½") Gradino Nat/Ret	P	9,5	3	1,080	20,50	20	-	-	-
30×60 (12"×24") Gradino Nat/Ret	P	9,5	6	1,080	21,50	36	-	-	-
6,5×119,5 (2½"×47½") Battiscopa Nat/Ret	P	9,5	8	0,621 m.l. 9,60	12,50	48	-	-	-
8×60 (3¼"×24") Battiscopa Nat/Ret	P	9,5	10	0,480 m.l. 6,00	11,00	72	-	-	-

# Pezzi Speciali

Special pieces  
Formstücke  
Pièces spéciales

Battiscopa Nat/Ret 8×60 – 3¼"×24" ± 9,5

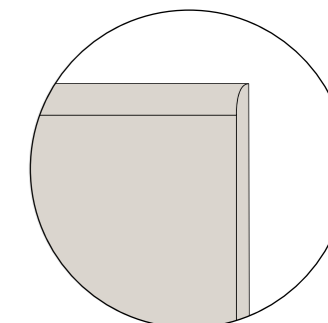
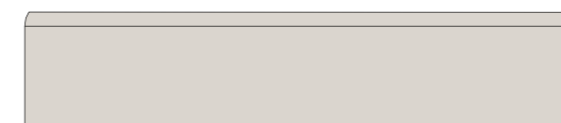

Battiscopa Nat/Ret 6,5×119,5 – 2½"×47½" ± 9,5

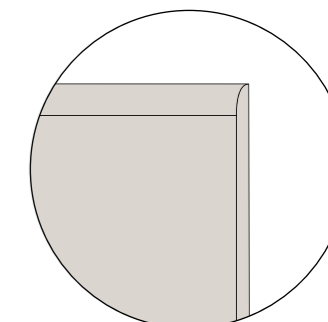
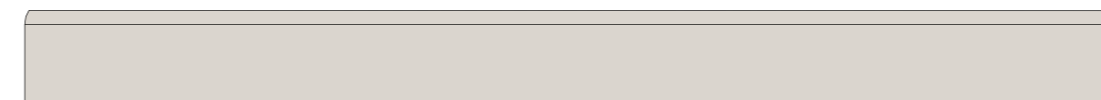

Gradino Nat/Ret 30×60 – 12"×24" ± 9,5  
(Becco civetta e fresature tecniche - bullnose edge with grooves)

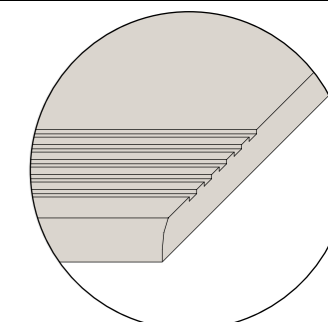

Gradino Nat/Ret 30×119,5 – 12"×47½" ± 9,5  
(becco civetta tecnico - bullnose edge)

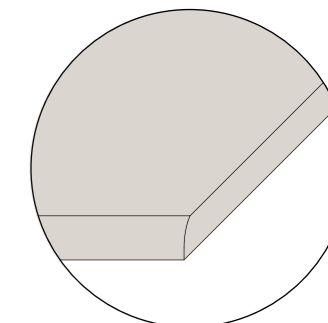
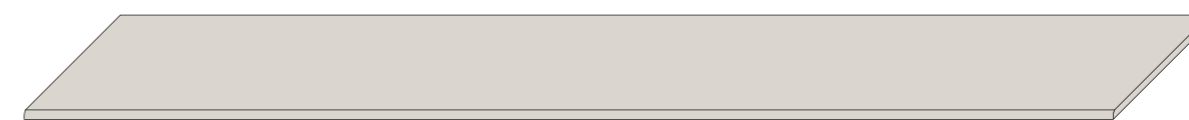

# Caratteristiche Tecniche

Technical characteristics  
Technische daten  
Caracteristiques techniques

CLASSIFICAZIONE SECONDO NORME CEN/ISO GRUPPO B1A EN 14411 - ISO 13006 - CLASSIFICATION IN ACCORDANCE WITH CEN/ISO STANDARDS B1A EN 14411 - ISO 13006  
KLASSIFIZIERUNG GEMÄSS CEN/ISO-NORMEN GRUPPE B1A EN 14411 - ISO 13006 - CLASSIFICATION SELON LES NORMES CEN/ISO GROUPE B1A EN 14411 - ISO 13006

CARATTERISTICA TECNICA TECHNICAL CHARACTERISTIC TECHNISCHE DATE CARACTÉRISTIQUE TECHNIQUE	NORMA NORM NORME	VALORE PRESCRITTO VALUE REQUIRED NORMVORGABE VALEUR PRESCRITE	VALORE MEDIO MEAN VALUE MITTELWERT VALEUR MOYENNE CERAMICHE PIEMME FLOOR AND MORE	USA TESTS 	VALORE MEDIO MEAN VALUE MITTELWERT VALEUR MOYENNE CERAMICHE PIEMME FLOOR AND MORE	
LUNGHEZZA E LARGHEZZA LENGHT AND WIDTH / LANGE UND BREITE / LONGUEUR ET LARGEUR		±0,6% (±2,00 MM)				
SPESORE THICKNESS / STÄRKE / EPAISSEUR		±5% (±0,5 MM)				
RETILINEITÀ LATI WARPAGES OF EDGES / GERADHEIT DER KANTEN / RÉCITITUDE DES ARÊTES	ISO 10545.2	±0,5% (±15 MM)	CONFORME IN ACCORDANCE ERFÜLLT CONFORME	ASTM C-499 ASTM C-485 ASTM C-502	IN ACCORDANCE	
ORTOGONALITÀ WEDGING / RECHTWINKLIGKEIT / ORTHOGONALITÉ		±0,5% (±2,00 MM)				
PLANARITÀ FLATNESS / PLANITÄT / PLANIMÉTRIE		±0,5% (±2,00 MM)				
ASSORBIMENTO % D'ACQUA WATER ABSORPTION WASSERANNAHME % ABSORPTION D'EAU %	ISO 10545.3	≤ 0,5%	CONFORME IN ACCORDANCE ERFÜLLT CONFORME	ASTM C-373	IN ACCORDANCE	
RESISTENZA ALLA FLESSIONE BENDING STRENGTH BIEGEZUGFESTIGKEIT RÉSISTANCE À LA FLEXION	ISO 10545.4	≥ 35N/MM <sup>2</sup>	CONFORME IN ACCORDANCE ERFÜLLT CONFORME	ASTM C-648 250 LBS OR GREATER	IN ACCORDANCE	
DILATAZIONE TERMICA LINEARE TRA 20° E 100° C LINEAR THERMAL EXPANSION BETWEEN 20° AND 100° C LINEARE WÄRMEAUSENDENUNG ZWISCHEN 20° UND 100° C DILATATION THERMIQUE LINÉAIRE ENTRE 20° ET 100° C	ISO 10545.8	SECONDO I DATI DEL COSTRUTTORE ACCORDING TO BUILDER'S SPECIFICATIONS LAUT ANGABEN DES HERSTELLERS SELON LES ÉLÉMENTS DU CONSTRUCTEUR	= 7X10 <sup>-6</sup> C <sup>-1</sup>			
RESISTENZA AGLI SBALZI TERMICI THERMAL SHOCK RESISTANCE TEMPERATURWECHSELBESTÄNDIGKEIT RÉSISTANCE AUX ÉCARTS DE TEMPÉRATURE	ISO 10545.9	RICHIESTA REQUEST BITTE DEMANDE	RESISTENTE RESISTANT WIDERSTEHEND RÉSISTANT			
RESISTENZA AL GELO FROST RESISTANCE FROSTBESTÄNDIGKEIT RÉSISTANCE AU GEL	ISO 10545.12	RICHIESTA REQUEST BITTE DEMANDE	RESISTENTE RESISTANT WIDERSTEHEND RÉSISTANT	ASTM C-1026	IN ACCORDANCE	
RESISTENZA ALL'ATTACCO CHIMICO RESISTANCE TO CHEMICAL ATTACK BESTÄNDIGKEIT GEGEN CHEMIKALIEN RÉSISTANCE À L'ATTAQUE CHIMIQUE	ISO 10545.13	SECONDO I DATI DEL COSTRUTTORE ACCORDING TO BUILDER'S SPECIFICATIONS LAUT ANGABEN DES HERSTELLERS SELON LES ÉLÉMENTS DU CONSTRUCTEUR	RESISTENTE RESISTANT WIDERSTEHEND RÉSISTANT	ASTM C-650	IN ACCORDANCE	
RESISTENZA DEI COLORI ALLA LUCE COLOURS RESISTANCE TO LIGHT LICHTBESTÄNDIGKEIT RÉSISTANCE DES COULEURS À LA LUMIÈRE	DIN 51094	NESSUNA ALTERAZIONE NO ALTERATION KEINE VERÄNDERUNG AUCUNE ALTERATION	CONFORME IN ACCORDANCE ERFÜLLT CONFORME			
RESISTENZA ALLE MACCHIE STAIN RESISTANCE FLECKENFESTIGKEIT RÉSISTANCE AUX TACHES	ISO 10545.14	≥ CLASSE 3 METODO DI PROVA DISPONIBILE TEST METHOD AVAILABLE VERFÜGBARE PRÜFMETHODE METHODE D'ESSAI DISPONIBLE	CONFORME IN ACCORDANCE ERFÜLLT CONFORME			
	DIN 51130 *	9 s R s13	NAT	R10	ASTM C-1028 * COF	NAT
			ANTISLIP	R11	≥ 0,6 DRY ≥ 0,6 WET	ANTISLIP
RESISTENZA ALLO SCIVOLAMENTO SLIPPAGE RESISTANCE RUTSCHSICHERHEIT RÉSISTANCE AU GLISSEMENT	DIN 51097 *	A,B,C	NAT	A+B	ANSI * 137.1-2012 DCOF	NAT
			ANTISLIP	A+B+C	> 0,42 WET	ANTISLIP
			NAT			
PENDULUM SLIP TEST	BS EN 7976-2*	> 36 DRY > 36 WET				ANTISLIP

\*TRATTANDOSI DI NORMATIVE NAZIONALI, I METODI DI PROVA, I REQUISITI E LE CLASSIFICAZIONI VARIANO DA PAESE A PAESE. IL VALORE ATTESO DALLA RESISTENZA ALLO SCIVOLAMENTO DELLA PRODUZIONE DI INDUSTRIE CERAMICHE PIEMME S.P.A., PUÒ VARIARE IN BASE AL LOTTO PRODUTTIVO. SPECIFICA DOCUMENTAZIONE È DISPONIBILE SU RICHIESTA.  
TEST METHODS, REQUIREMENTS AND CLASSIFICATIONS DIFFER FROM COUNTRY TO COUNTRY, ACCORDING TO THE NATIONAL REGULATIONS. THE EXPECTED VALUE OF SLIPPAGE RESISTANCE OF PRODUCTS BY INDUSTRIE CERAMICHE PIEMME S.P.A. MAY VARY DEPENDING ON THE PRODUCTION BATCH. SPECIFIC DOCUMENTS ARE AVAILABLE UPON REQUEST.  
PRÜFVERFAHREN, ERFORDERNISSE UND KLASSIFIKATIONEN SIND VERSCHIEDEN VON LAND ZU LAND, GEMÄSS DER NATIONALEN VORSCHRIFTEN. DER ERWARTUNGSWERT DER RUTSCHSICHERHEIT DER PRODUKTE VON INDUSTRIE CERAMICHE PIEMME S.P.A. KANN SICH - JE NACH DER PRODUKTIONSPARTIE - VERÄNDERN. SPEZIFISCHE UNTERLAGEN SIND AUF VERLANGEN ZUR VERFÜGUNG.  
LES MÉTHODES D'ESSAI, LES RÉQUISITIONS ET LES CLASSIFICATIONS CHANGENT DE PAYS À PAYS, SELON LES RÉGLEMENTATIONS NATIONALES. LA VALEUR ATTENDUE DE RÉSISTANCE AU GLISSEMENT DES PRODUITS DE INDUSTRIE CERAMICHE PIEMME S.P.A. PEUT VARIER EN FONCTION DU LOT DE PRODUCTION. UNE DOCUMENTATION SPÉCIFIQUE EST DISPONIBLE SUR DEMANDE.

ELENCO DELLE SERIE CERTIFICATE E CLASSIFICAZIONI DISPONIBILI A RICHIESTA - LIST OF CERTIFIED SERIES AND CLASSIFICATIONS AVAILABLE UPON REQUEST  
LISTE DER GEPRÜFTEN SERIE UND KLASSIFIZIERUNGEN AUF ANFRAGE ERHÄLTICH - LISTE DES SERIES CERTIFIÉES ET DES CLASSEMENTS DISPONIBLES SUR DEMANDE



CERAMICHE PIEMME  
FLOOR AND MORE



# Norme per la posa e la manutenzione

Installation and maintenance instructions  
Verlegung, reiningung und pflege  
Guide a la pose et l'entretien

- Per i prodotti rettificati consigliamo una fuga di 2 mm per un migliore risultato di posa.
- Per una migliore resa estetica Piemme consiglia stuccature colorate in tinta con le piastrelle. Verificare, prima dell'utilizzo, la compatibilità ed idoneità dei riempitivi per fughe con il prodotto ceramico.
- Rimuovere le eccedenze dei riempitivi per fughe quando gli stessi sono ancora freschi.
- Attenersi scrupolosamente alle istruzioni indicate dai produttori dei riempitivi per fughe.
- Per eliminare completamente i residui di posa, che potrebbero compromettere la manutenzione ordinaria e le caratteristiche del prodotto, a posa ultimata, procedere con la pulizia utilizzando prodotti adeguati, a base Acida max 3%, rispettando le indicazioni del produttore. Osservare assolutamente i limiti di tempo indicati nelle istruzioni: un contatto troppo prolungato con questi prodotti potrebbe provocare il danneggiamento della superficie.
- Gli eventuali aloni che si dovessero presentare dopo la posa di materiali lappati o levigati si potranno facilmente eliminare utilizzando un prodotto idoneo, a base Alcalina.
- Riguardo l'utilizzo di materiali ceramici all'esterno, pure riconfermando l'ingelività dei prodotti Piemme in gres porcellanato, in conformità alle vigenti normative europee EN 14411/ISO 13006-ISO 10545.12, occorre attenersi ad alcune fondamentali norme previste per la posa all'esterno, atte a rendere inattaccabili al gelo i predetti pavimenti. Le condizioni più importanti da rispettare sono: le opportune pendenze, le impermeabilizzazioni, i giunti di dilatazione, e l'uso di idonei materiali per la posa.
- Decorati realizzati con smalti e metalli preziosi è indispensabile proteggere la superficie durante la posa, non utilizzare assolutamente prodotti abrasivi e/o acidi, ma solo acqua e sapone neutro. Il produttore non risponde di eventuali danni a questi preziosi materiali causati da "sfregamenti" durante la posa in opera. Per nessun motivo saranno accettate contestazioni relative a materialeposato.

TIPO DI SPORCO	INDICAZIONI PER LA PULIZIA
Birra, Caffè, Gelato, Vino Gomma Pneumatico, Grassi vegetali e animali, Inchiostri, Lampostili Olii Meccanici, Residui di scotch Ollo di lino, PennarelloResine Smalti, Tintura per capelli	Prodotti a Base Alcalina
Cera protettiva anti-abrasione, Depositi calcarei, Macchie di ruggine	Prodotti a Base Acida
Cera di candela, Residui di scotch	Solventi
Per ulteriori informazioni specifiche consultare l'area tecnica sul sito Piemme: <a href="http://www.ceramichepiemme.it">www.ceramichepiemme.it</a>	

- For better installation results of rectified products, we suggest 2 mm joint.
- For a better aesthetic finish, Piemme recommends using jointing colours that match the tiles.
- Please check, before using, the compatibility and suitability of grouting material with the ceramic tile.
- Clean away the excess of grouting materials while they are still fresh.
- Follow carefully the instructions pointed out by the producers of tile grouting materials.
- To completely eliminate installation residues, which could negatively affect routine maintenance and product characteristics once installation has terminated, proceed to clean using adequate products, with max. 3% Acid base, following the manufacturer's instructions. Always closely abide by the time limits indicated in the instructions: prolonged contact with these products may cause damage to the surface.
- Any rims that appear after installing lapped or polished materials can be easily eliminated using a suitable Alkaline-based product.
- With regard to the use of ceramic materials outdoors, while once more reiterating that Piemme porcelain stoneware products are frost-proof, in compliance with applicable European standards EN 14411/ISO 13006-ISO 10545.12, a number of fundamental procedures must be followed for outdoor installation, suitable for making the aforementioned floors resistant to frost. The most important aspects are: suitable gradients, waterproofing, expansion joints, and the use of suitable installation materials.
- Decorations made with glazes and precious metals It is most important to protect the surface during installation. Never use abrasive and/or acid products, only water and neutral soap. The manufacturer disclaims liability in case of any damage to these precious materials caused by "rubbing" during installation. Under no circumstances will disputes be accepted relating to the installed material.

TYPE OF STAIN	CLEANING SUGGESTIONS
beer, coffee, wine, ice cream vegetable and animal fats, rubber, remains of scotch tape, grease from machines, linseed oil, felt tip pens, paints, inks, hair dye	Alkaline-based detergent
protective anti-abrasion wax, calcareous residuals, rust stains	Acid-based detergent
candle wax, remains of scotch-tape	Solvents
For further specific details please visit the technical area on Piemme website: <a href="http://www.ceramichepiemme.it">www.ceramichepiemme.it</a>	

- Damit sich eine bessere Verlegung von geschliffenen Produkten ergibt, empfehlen wir eine Fugenbreite von 2 mm.Für ein optisch perfektes Ergebnis empfiehlt Piemme, die Fugen farblich auf die Fliesen abzustimmen.
- Prüfen sie bitte, vor der Verwendung, die Zweckmäßigkeit und die Verträglichkeit des Fugenfüllmittels mit den Keramikfliesen.
- Bitte entfernen sie das überflüssige Fugenfüllmittel wenn es noch frisch ist.
- Folgen sie bitte sorgfältig die von dem Herstellern des Fugenfüllmittels angegebenen Bedienungsvorschriften.
- Zur vollkommenen Entfernung der Verlegerückstände, die die normale Pflege erschweren und die Merkmale des Produkts beeinträchtigen könnten, nach der Verlegung geeignete Reinigungsmittel auf max. 3% Säurebasis verwenden und bei der Reinigung die Hinweise des Herstellers beachten. Die angegebenen Zeiten keinesfalls überschreiten: ein zu lange andauernder Kontakt mit diesen Produkten kann Beschädigungen der Oberfläche verursachen.
- Eventuelle nach der Verlegung von geläppter oder geschliffenem Material sichtbare Schleier lassen sich einfach mit entsprechenden, alkalischen Produkten entfernen.
- Auch wenn die Piemme-Feinsteinzeugprodukte gemäß den europäischen Normen EN 14411/ISO 13006-ISO 10545.12 frostbeständig sind, müssen beim Einsatz keramischer Materialien im Freien einige Grundregeln beachtet werden, damit die Bodenbeläge nicht vom Frost angegriffen werden können. Die wichtigsten Voraussetzungen sind: korrektes Gefälle, Abdichtung, Dehnungsfugen sowie geeignetes Verlegematerial.
- Dekore mit Glasuren und Edelmetallen Während der Verlegung muss die Oberfläche unbedingt abgedeckt werden. Es dürfen keine scheuernden und/oder säurehaltigen Produkte verwendet werden, sondern ausschließlich Wasser und neutrale Seife. Der Hersteller haftet nicht für eventuelle, während der Verlegung durch Abrieb entstandene Schäden an diesen hochwertigen Materialien. Reklamationen von bereits verlegtem Material werden in keinem Fall akzeptiert.

VERSCHMUTZUNGSART	REINIGUNGSHINWEISE
Bier, Wein, Eis, Kaffee Tierische oder pflanzliche Fette Gummi, Kleberbandresten Schmieröl, Tinte, Leilöl, Filzstift, Harz oder Lack, Haarfarbe	Alkalische Reinigungsmittel
Kratzschutz-Wachs, Kalkablagerunge, Rostflecken	Säure-Reinigungsmittel
Kerzenwachs Kleberbandresten	Lösungsmittel
Weitere Einzelheiten finden Sie in dem technischen Bereich des Piemme website: <a href="http://www.ceramichepiemme.it">www.ceramichepiemme.it</a>	

- Pour obtenir le meilleur résultat de pose de produits rectifiés, il est conseillé de réaliser un joint de 2 mm.
- Pour parfaire l'effet esthétique obtenu, Piemme conseille de confectionner des joints de la même couleur que les carreaux.
- Vérifier avant la pose la compatibilité et convenance des remplissages pour joints avec le produit céramique.
- Enlever les surplus des remplissages pour joints alors qu'ils sont encore frais.
- Respecter scrupuleusement les instructions indiquées par les fabricants de remplissages pour joints.
- Pour éliminer complètement tout résidu de pose pouvant gêner l'entretien courant et altérer les caractéristiques du produit, il est conseillé, à la fin de la pose, de procéder au nettoyage du carrelage avec des produits à base acide maximum 3% et de respecter les consignes du fabricant. Suivre impérativement les délais indiqués dans la notice car le contact trop prolongé de ces produits pourrait endommager la surface.
- Pour éliminer facilement la présence éventuelle de cernes après la pose de carreaux rodés ou polis, utiliser un produit à base alcaline.
- Pour ce qui est de la pose à l'extérieur, bien que les produits Piemme en grès cérame soient ingélifs, conformément aux normes européennes EN 14411/ISO 13006-ISO 10545.12, il convient cependant de respecter quelques règles fondamentales de manière à rendre le carrelage inattaquable au gel. Les conditions les plus importantes à remplir sont: le degré d'inclinaison, l'imperméabilisation, les joints de dilatation et l'utilisation de matériaux de pose appropriés.
- Décors réalisés avec des émaux et des métaux précieux Il est indispensable de protéger la surface pendant la pose. N'utiliser en aucun cas des produits abrasifs et/ou acides mais uniquement de l'eau et du savon neutre. La fabricant ne répond pas des dommages éventuels de ces matériaux précieux causés par le frottement pendant la pose. Aucune réclamation, quelle qu'elle soit, concernant le matériau posé ne sera acceptée.

TYPE DE TACHE	NETTOYAGE CONSEIL
Bière, Vin, Glace, Café, Graisses végétales et animales, Encres, Résidus de scotch, Huile de graisseage, Hile de lin Crayon feutre Emaux, Teinture pour cheveux, Caoutchouc pour pneus	Détergents à base alcaline
Cire de protection anti abrasion, Dépôts de calcaire, Tache de rouille	Détergents à base d'acide
Cire de bougie Résidus de scotch	Solvant
Pour d'ultérieures informations spécifiques consulter le département technique du site Piemme: <a href="http://www.ceramichepiemme.it">www.ceramichepiemme.it</a>	

Reading Guide  
Leseanleitung  
Guide à la lecture

 Spessore  
Thickness  
Stärke  
Épaisseur

Variazione nelle sfumature di colore  
Color shade variations  
Variation der Farbnuancen  
Variation des nuances de couleur

 Fascia prezzo al metro quadrato  
Square meter price range  
Quadratmeter preisgruppe  
Niveau de prix au mètre carré

 V1 Aspetto uniforme  
Uniform appearance  
Gleichförmiges aussehen  
Aspect uniforme

 Fascia prezzo al pezzo  
Price range per pièce  
Stück preisgruppe  
Niveau de prix à la pièce

 V2 Variazione leggera  
Slight variation  
Leichte variation  
Variation légère

 V3 Variazione moderata  
Moderate variation  
Mäßige variation  
Variation modeste

 V4 Variazione casuale  
Random variation  
Zufällige variation  
Variation fortuite

---

Tutti i formati sono nominali.

All sizes are nominal.

Die Formate sind Nennwerte.

Tous les formats sont nominaux.

Gli spessori riportati in questo catalogo sono nominali e possono variare a seconda dei formati e delle finiture.

The thickness mentioned on this catalogue are nominal and can be different according to the sizes and the finishes.

Die in diesem Katalog angegebenen Fliesenstärke sind nominal und können, je nach Format oder Oberfläche, verschieden sein.

Les épaisseurs reportées sur ce catalogue sont nominales et peuvent varier suivant les formats et les finitions.

I colori e le caratteristiche estetiche dei prodotti sono quanto più possibile vicini a quelli reali, nei limiti consentiti dai processi di stampa.

The colours and appearance features of the products are as close as possible to reality, within the limitation of the printing process.

Die Farben und die ästhetischen Eigenschaften der Produkte entsprechen der Wirklichkeit, innerhalb den von dem Druckverfahren erlaubten Grenzen.

Les couleurs et les caractéristiques esthétiques sont fidèles aux couleurs et caractéristiques réelles dans les limites des procédés d'impression.

Project Management  
Mktg Piemme

Print  
Ruggeri Grafiche

Finito di stampare a Gennaio 2019  
Printed in January 2019

#### Una storia tutta italiana

Piemme dal 1962, anno della sua fondazione, è protagonista indiscussa del vero Made in Italy, quello fatto di eccellenza, passione e creatività. Oggi tutti i materiali Piemme sono prodotti con tecnologia d'avanguardia come la decorazione digitale inkjet HD, la cottura in forni ad energia pulita a recupero di calore, la rettifica e levigatura in linea "one roof" e la verifica elettronica dello standard qualitativo.

#### An all-Italian story

Since 1962, the year of its foundation, Piemme has been the undisputed protagonist of real Made in Italy, that which consists of excellence, passion and creativity. Today all Piemme materials are made using cutting-edge technology such as HD inkjet digital decoration, firing in heat-recycling clean-energy kilns, "one roof" grinding and polishing line and electronic quality standard control.

#### Eine ganz italienische Geschichte

Seit dem Gründungsjahr 1962 ist Piemme ein unangefochtener Hauptakteur des echten Made in Italy: jenem, das auf Exzellenz, Leidenschaft und Kreativität gründet. Alle Piemme Erzeugnisse werden heute unter Einsatz von Spitzentechnologie produziert, wie zum Beispiel mit der digitalen Inkjet-Dekoration, dem Brennen in Öfen mit grüner Energie und Wärmerückgewinnung, dem Schleifen und Polieren in der Linie „unter einem Dach“ sowie der elektronischen Prüfung des Qualitätsniveaus.

#### Une histoire toute italienne

Depuis 1962, l'année de sa fondation, Piemme est la protagoniste indiscutée du Made in Italy, basé sur l'excellence, la passion et la créativité. Aujourd'hui toutes les phases du cycle de fabrication Piemme sont issues d'une technologie à l'avant-garde comme la décoration numérique inkjet HD, la cuisson dans des fours à énergie propre et à récupération de chaleur, la rectification et le polissage en ligne "one roof" et la vérification électronique de la qualité.

# CERAMICHE PIEMME

FLOOR AND MORE

INDUSTRIE CERAMICHE PIEMME S.P.A.  
VIA DEL CROCIALE 42/44, 41042 FIORANO (MO) - ITALY  
T. +39 0536.849111 - F. +39 0536.849402  
WWW.CERAMICHEPIEMME.IT - INFO@CERAMICHEPIEMME.IT