

# Materia

6 COLOURS

5 SIZES

3 SURFACES

Materia is conceived to introduce a new expression of ceramics. A noble material with a great history relaunches its creative potential thanks to the graphic technique and the diverse esthetics of materials like metal, stone and ceramics itself.

Materia nasce dall'idea sviluppata in Piemme per una nuova espressione della ceramica, una materia nobile con una grande storia creativa che ritrova e rilancia il proprio estro originario e, grazie alla sua tecnica grafica, analizza l'estetica di materie differenti, come il metallo, la pietra e la ceramica stessa,

Mit „Materia“ möchte Piemme der Keramik einen neuen Ausdruck verleihen. Das edle und geschichtsträchtige Material findet zurück zu seinen Wurzeln, erfindet sich neu und analysiert mit seiner graphischen Technik seine eigene Ästhetik sowie die anderer Materialien wie Metall und Stein.

« Materia » est l'aboutissement d'une idée développée par Piemme: donner à la céramique, matière noble, riche d'une histoire nourrie de créativité, une nouvelle forme d'expression où elle puisse retrouver son style originel. Ses techniques graphiques lui permettent d'analyser les dimensions esthétiques de matières comme le métal, la pierre ainsi que la céramique.

## Materia



Spazi Residenziali  
Residential Spaces

P. 5

Spazi Pubblici  
Public Areas

P. 21

Informazioni Tecniche  
Technical Information

P. 45

La forza espressiva della ceramica secondo Piemme, riesce a dare nuova eleganza ed appeal ad una materia di per se fredda come il metallo, proprio grazie alla possibilità di fondervi e compenetrarvi altri aspetti di una materia affascinante come la pietra, arricchendo con grande profondità le nuances più flat del metallo stesso.

The expressive force of Piemme ceramics bestows new elegance and appeal on metal, an intrinsically cold material, through this ability to merge and mingle it with other aspects native to stone with all its natural beauty, thus enhancing the flatter shades of metal with great depth.

Mit ihrer Ausdruckskraft schafft es die Keramik von Piemme, einem an sich kalten Material wie Metall eine neue Eleganz und Ausstrahlung zu verleihen. Die Keramik verschmilzt mit dem Metall und bringt die Eigenschaften eines weiteren faszinierenden Materials mit ein: des Steins. So erhält das eher flach wirkende Metall mehr Tiefe.

Cette force expressive de la céramique revue par Piemme réussit à insuffler une nouvelle élégance et un nouvel attrait à une matière comme le métal, intrinsèquement froide. Elle y parvient parce qu'elle peut y incorporer d'autres aspects de ce matériau fascinant qu'est la pierre, enrichissant ainsi de ses nuances profondes celles, plus plates, du métal.

# Spazi Residenziali

Residential Spaces  
Wohnanlagen  
Espaces Résidentiels

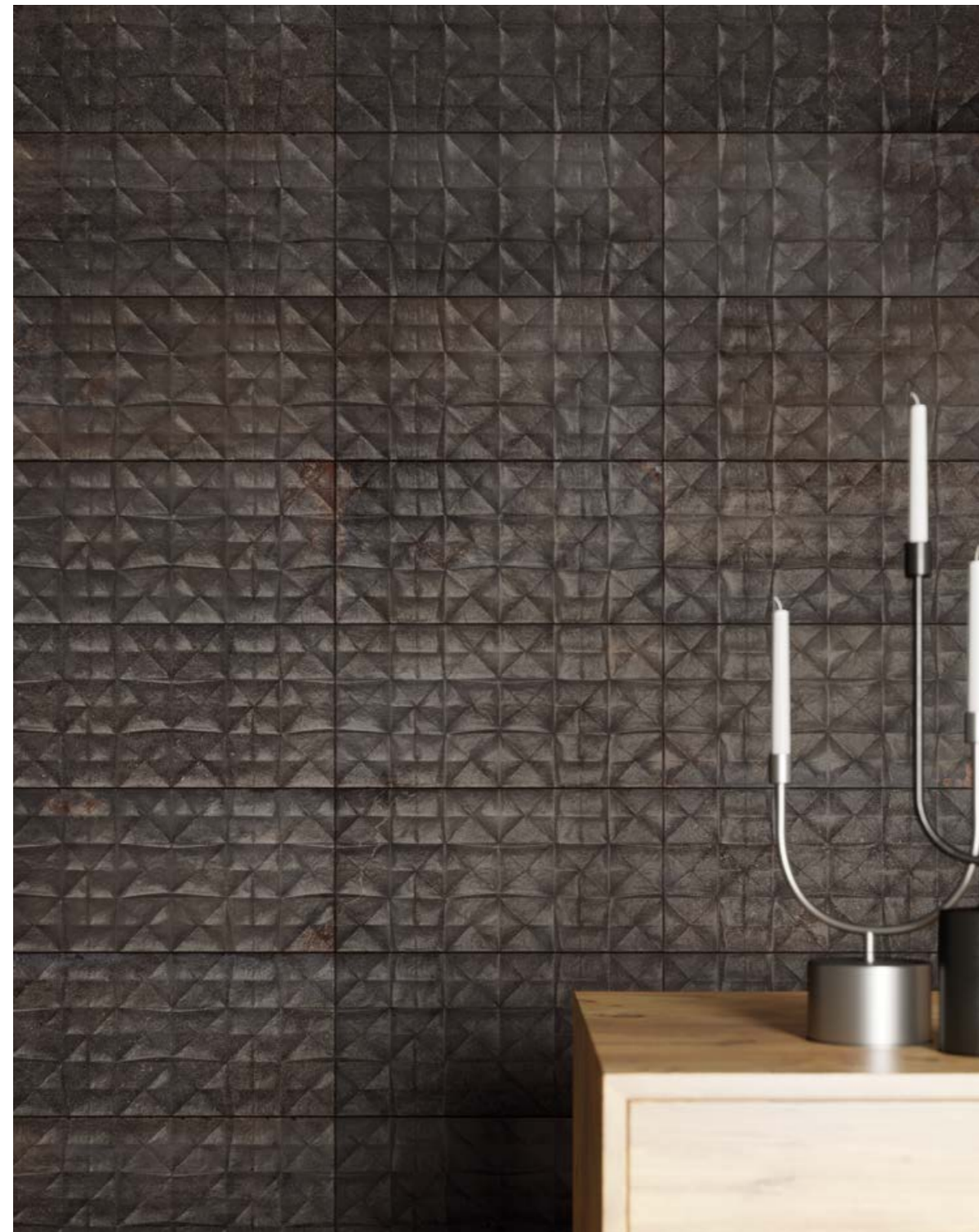

COLORI / COLOURS

AMBIENTI / AMBIENT

PAGINA / PAGE

Deep / Shimmer

Living

6

Deep

Living

8

Reflex

Living

10

Opal / Nacre

Bathroom

13

Shimmer / Rust

Bathroom

17

Materia  
Residential Spaces

5







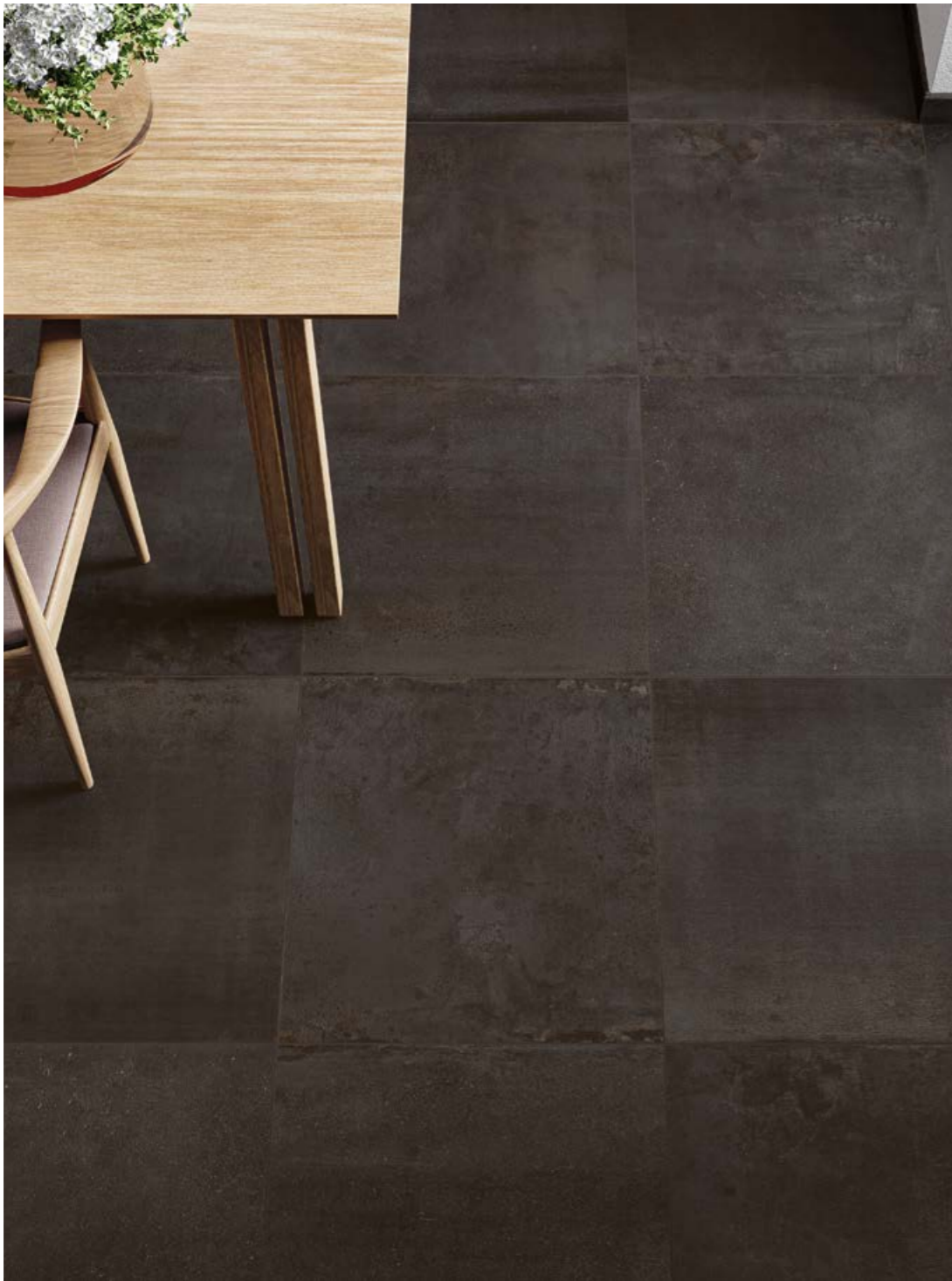







Ceramics is restored to its status as a fine material, now with new vitality and a striking personality. The "Materia" collection, with its expressive peculiarities and 3D structures, is superior to any other ceramic surface.

Das edle keramische Material findet einen neuen Lebens und eine besondere Persönlichkeit. Die Serie „Materia“ unterscheidet sich mit ihren ästhetischen Merkmalen und ihren 3D-Strukturen von jeder anderen Oberfläche aus Keramik.

La noble matière céramique retrouve dès lors sa sève vitale et sa personnalité marquée. Ses particularités expressives et ses structures 3D permettent à la série « Materia » de se distinguer des autres surfaces céramiques.

La nobile materia ceramica ritrova una nuova linfa vitale e una spiccata personalità. La serie "Materia" con le sue peculiarità espressive e le strutture 3d emerge rispetto qualunque altra superficie ceramica.



Materia  
Public Areas







## Shimmer / Rust

Starting from the tactile effects inspired by the various glossy or oxidised metals and the natural look of stone, in "Materia" our designers have created a new material.

Ausgehend von der Wirkung unterschiedlicher, glänzender oder oxidiertes Metalle und von der natürlichen Optik des Steins haben unsere Designer „Materia“ wie einen neuen Stoff geschaffen.

60×119,5 - 24"×47½" Naturale Rettificato

S'appuyant sur les effets de matières, brillants ou oxydés, suggérés par les différents métaux, ainsi que sur l'aspect naturel de la pierre, nos designers ont créé une nouvelle matière : « Materia ».

Partendo dagli effetti materici suggeriti dai differenti metalli, lucenti o ossidati e dall'aspetto naturale della pietra, i nostri designer hanno creato una nuova "Materia".

119,5×119,5 - 47½"×47½" Naturale Rettificato

60×60 - 24"×24" Jade Naturale Rettificato



Materia  
Public Areas



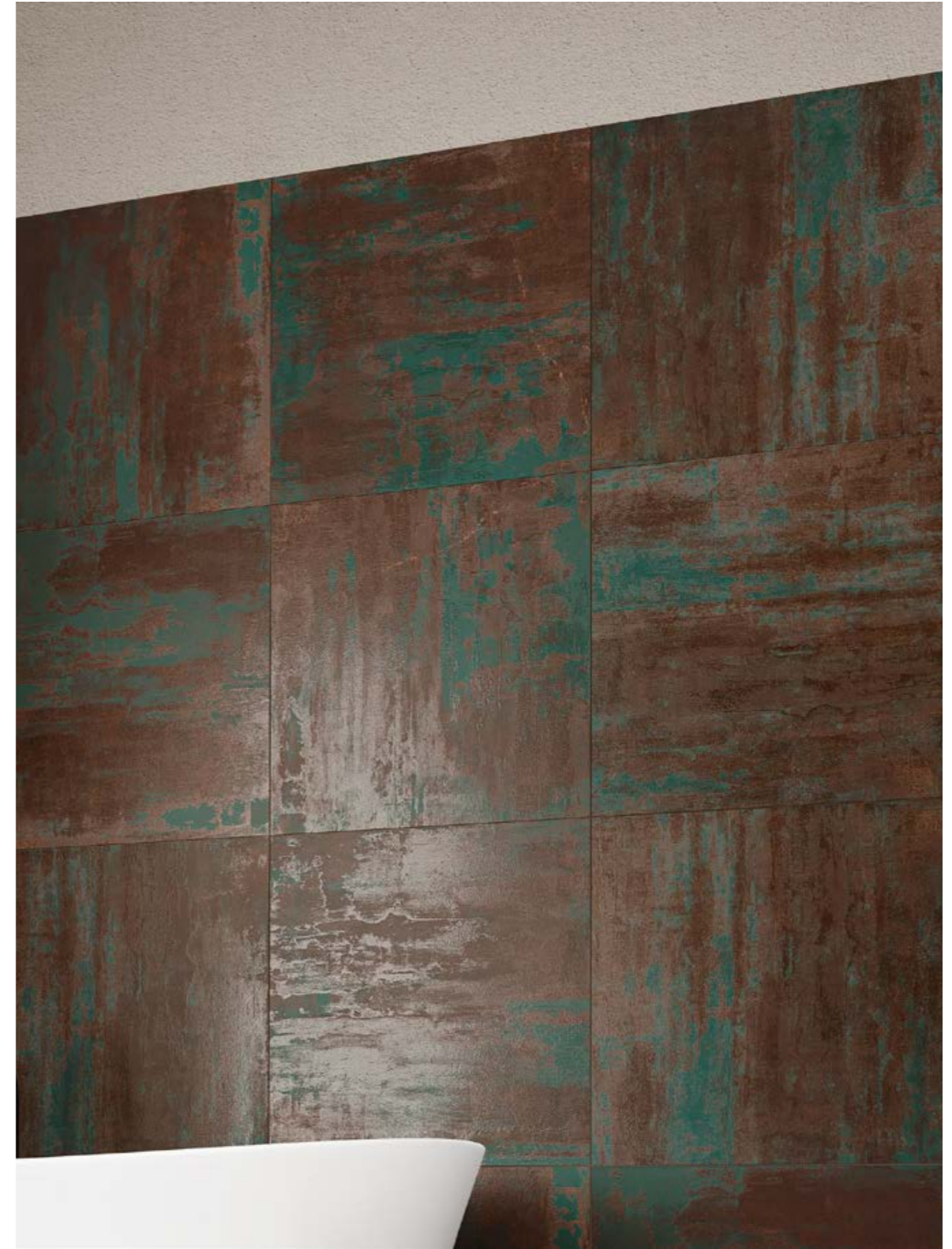



# Spazi Pubblici

Public Areas  
 Öffentliche Räumlichkeiten  
 Espaces Publics



COLORI / COLOURS

AMBIENTI / AMBIENT

PAGINA / PAGE

|                    |                   |    |
|--------------------|-------------------|----|
| Deep / Rust / Opal | Restaurant        | 23 |
| Opal / Deep        | Museum Lobby      | 24 |
| Reflex / Nacre     | Food Court        | 29 |
| Reflex             | Bathroom          | 33 |
| Rust / Shimmer     | Museum Restaurant | 36 |
| Reflex             | Museum Cafè       | 40 |



## Deep / Rust / Opal

An unusual effect, creating surfaces that merge metal, Corten steel, stone and ceramic in a refined, contemporary look.

Eine ganz neue Wirkung für Oberflächen, die Metall, Cortenstahl, Stein und Keramik in einer raffiniertmodernen Ästhetik verbinden.

Un effet inédit sur des surfaces où métal, corten, pierre et céramique se conjuguent pour créer une esthétique raffinée et contemporaine.

Effetto inedito per superfici che coniugano metallo, corten, pietra e ceramica, in un'estetica raffinata e contemporanea.

30×60 - 12"×24" Garage Naturale Rettificato / 60×119,5 - 24"×47½" Naturale Rettificato / 119,5×119,5 - 47½"×47½" Naturale Rettificato

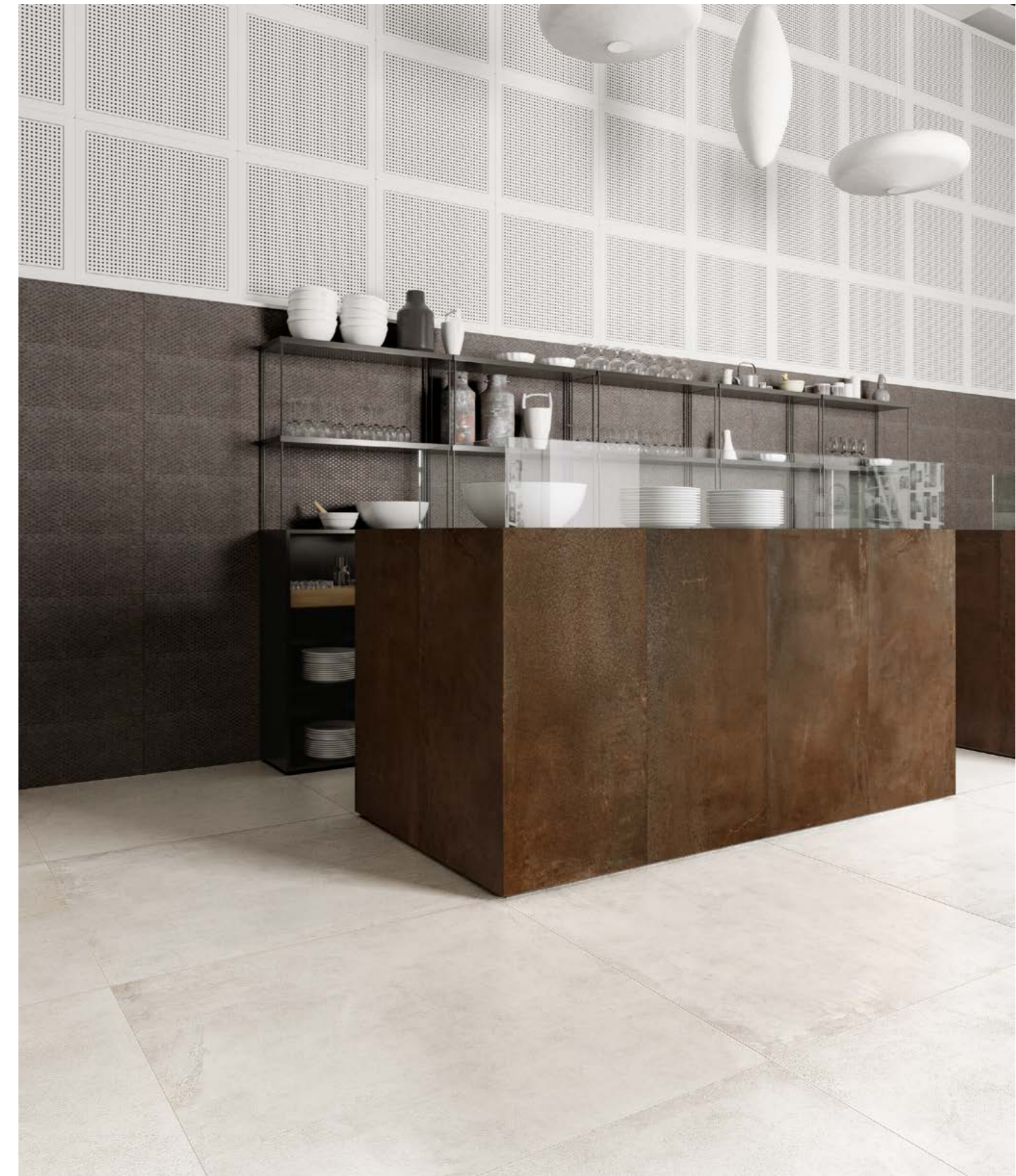











## Nacre

Thanks to sophisticated production technologies, "Materia" combines the ground look typical of handpolished metal with the small flaws that denote genuine craftsmanship.

Dank ausgeklügelter Produktionstechniken vereint „Materia“ die typische Glätte von handgeschliffenem Metall mit den kleinen Schönheitsfehlern von Handwerksprodukten.

Grâce à des technologies de production de pointe, « Materia » associe l'effet de rodage typique du métal poli à la main aux petites imperfections propres au travail artisanal.

Grazie a sofisticate tecnologie produttive "Materia" abbina l'effetto di smerigliatura tipico del metallo levigato a mano, alle piccole imperfezioni della lavorazione artigianale.

60×119,5 - 24"×47½" Lappato Rettificato



Materia  
Public Areas







## Reflex

The unusual aesthetic synthesis generated by this blending of materials has given us a collection rich in contemporary combinations.

Aus der neuartigen ästhetischen Synthese von Stoffen entsteht eine facettenreiche und moderne Kollektion.

La synthèse esthétique née de la fusion des matières a engendré une collection riche de combinaisons contemporaines.

La sintesi estetica inedita nata dalla fusione tra materie, ha generato una collezione ricca di combinazioni contemporanee.

30x60 - 12"x24" Lappato Rettificato / 30x119,5 - 12"x47½" Raku Warm Naturale Rettificato / 60x60 - 24"x24" Naturale Rettificato



Materia  
Public Areas









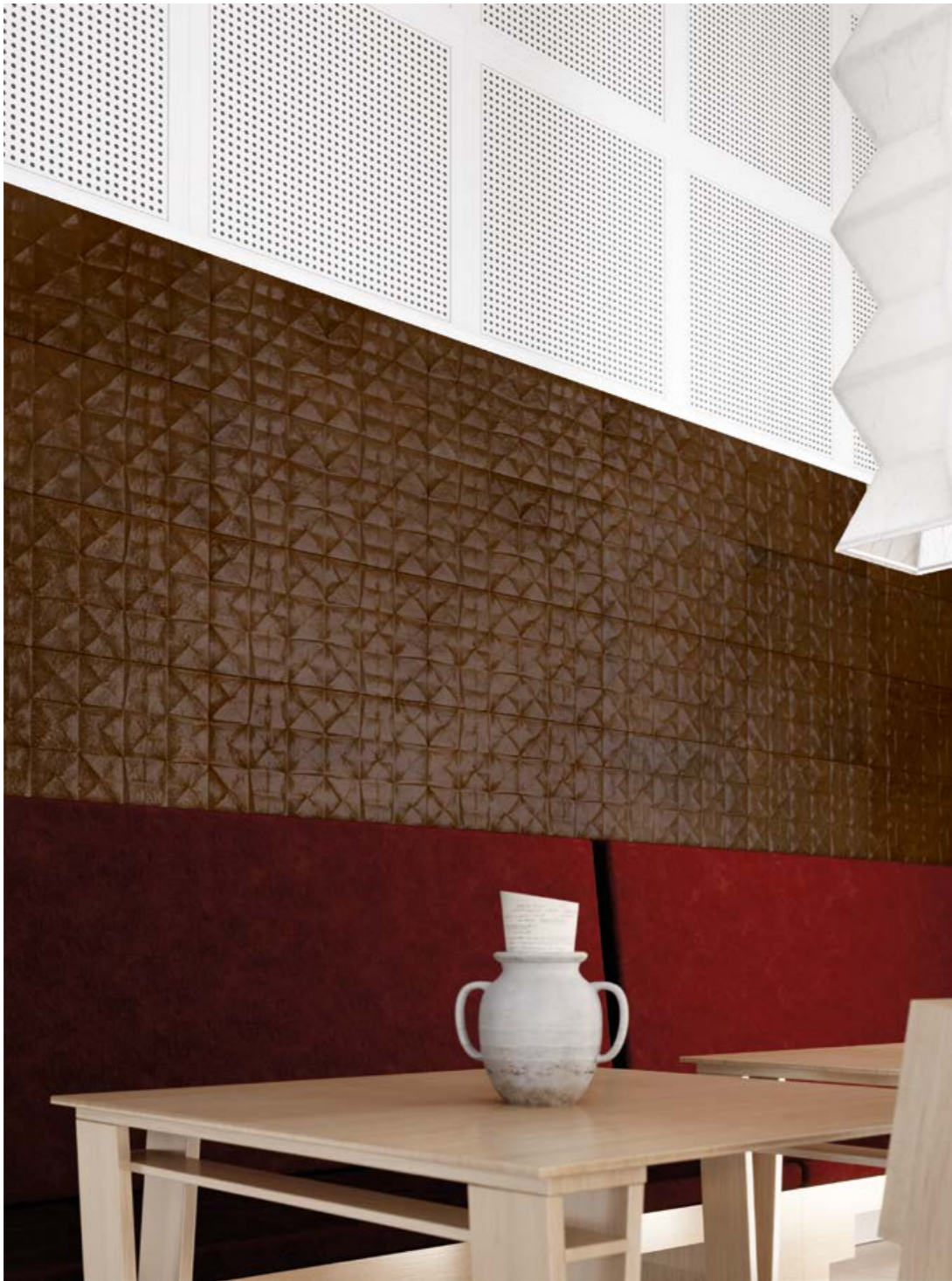







## Reflex

The perfect solution for coordinating an interior and outdoor mood with a floor that maintains the same design as the interior version, providing strength, style and durability.

Die perfekte Lösung für eine koordinierte Oberfläche innen wie außen, mit einem Bodenbelag, der mit dem gleichen Design der Version für Innenräume Beständigkeit und Langlebigkeit an bietet.

La solution parfaite pour coordonner intérieur et extérieur par un revêtement de sol qui offre style, résistance et solidité.

La soluzione perfetta  
per coordinare il mood interno  
ed esterno con un pavimento  
che offre resistenza, stile e durabilità.

90x90 - 36"x36" Grip Rettificato 20MM

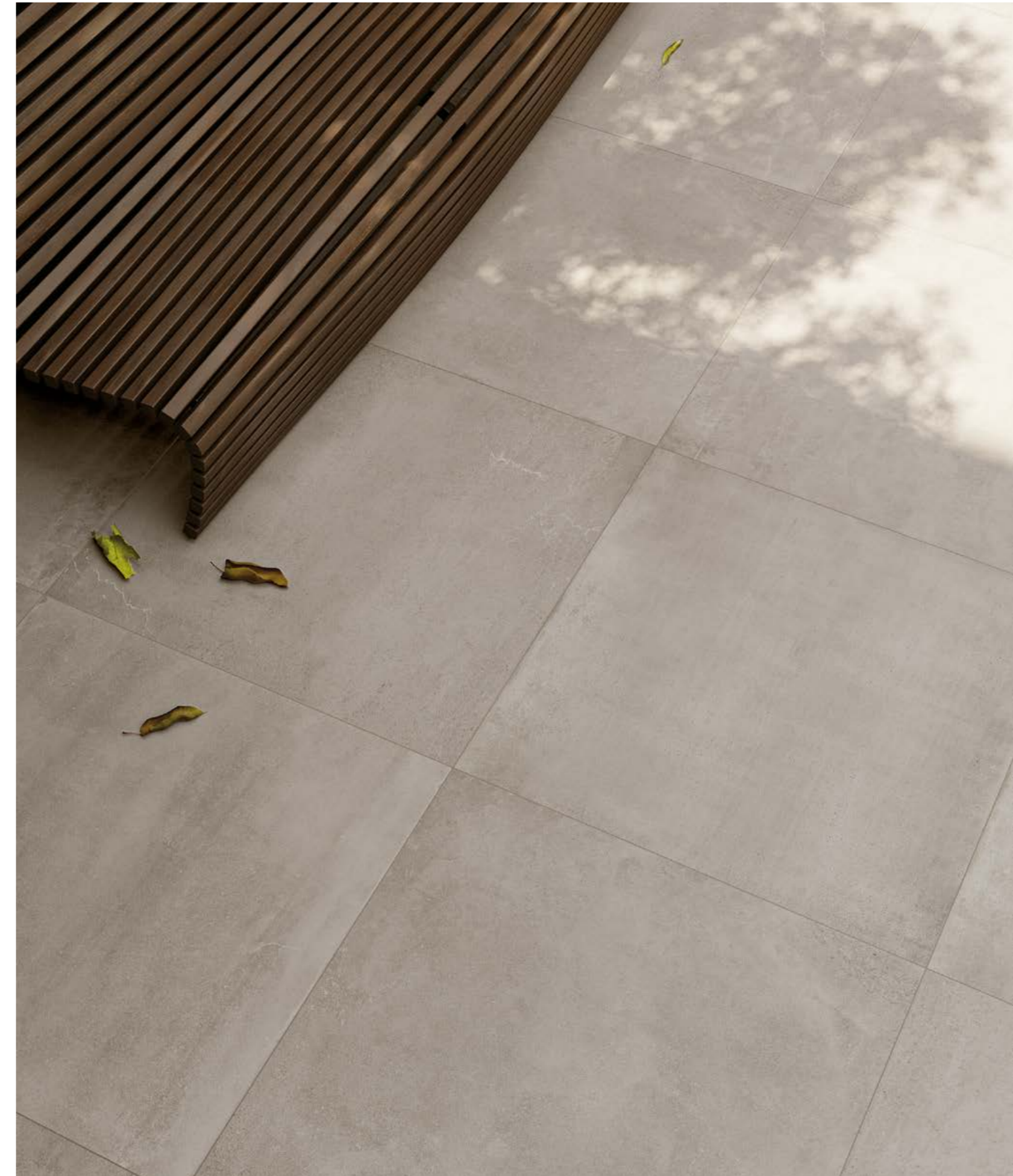

Materia  
Public Areas



# Informazioni Tecniche

## 6

Colori  
Colours  
Farben  
Couleurs

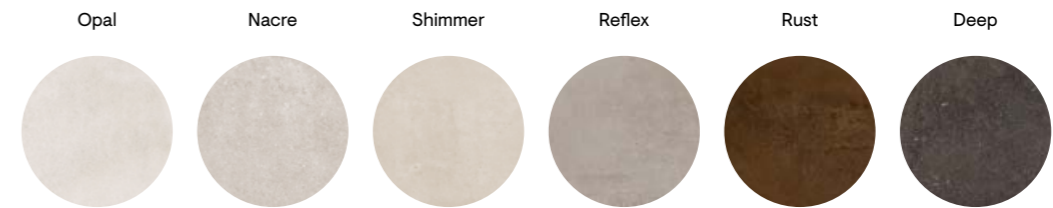

## 5

Formati  
Sizes  
Formate  
Formats

119,5×119,5   \*60×119,5   90×90   60×60   30×60  
47½"×47½"   24"×47½"   36"×36"   24"×24"   12"×24"



\*formato modulare con 60x60 e 30x60 / modular size, can be matched with 60x60 and 30x60 size /  
modulares, sprich mit dem Format 60x60 und 30x60 kombinierbares Format / format modulaire pouvant être coordonné au format 60x60 et 30x60

## 3

Spessori  
Thickness  
Stärke  
Epaisseur

9   9,5   20

## 3

Superfici  
Surfaces  
Oberflächen  
Surfaces

Naturale Lappato Grip

## 2

Strutture 3D  
3D structures  
Strukturen  
Décorations en relief

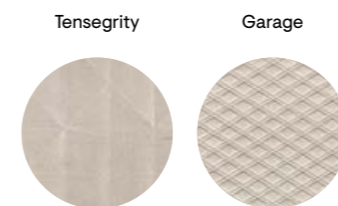

## i

Effetto Pietra - Metallo  
Stone Look - Metal  
Natursteinoptik - Metall  
Effet Pierre - Métal

Rivestimento  
Wall Tiles  
Wandfliesen  
Revêtement

Pavimento  
Floor Tiles  
Bodenfliesen  
Sol

Gres fine porcellanato  
Fine porcelain stoneware  
Feinsteinzeug  
Grès cérame fin

Tecnologia digitale  
Digital technology  
Digital technologie  
Technologie numérique





# Opal



± 9

119,5x119,5 - 47½"x47½"

**03071** | Materia Opal Nat/Ret  
**03075** | Materia Opal Lap/Ret



± 9,5

60x60 - 24"x24"

**02847** | Materia Opal Nat/Ret  
**02853** | Materia Opal Lap/Ret



± 9,5

60x60 - 24"x24"

**02981** | Materia Platinum Nat/Ret  
(mix 4 graphics)



± 9,5

30x60 - 12"x24"

**02827** | Materia Opal Nat/Ret  
**02834** | Materia Opal Lap/Ret



± 9,5

\*60x119,5 - 24"x47½"

**02859** | Materia Opal Nat/Ret  
**02866** | Materia Opal Lap/Ret



± 9,5

30x60 - 12"x24"

**02936** | Materia Garage Opal Nat/Ret



± 9,5

\*30x119,5 - 12"x47½"

**02944** | Materia Raku Warm Nat/Ret  
(handcrafted decor)



± 9,5

30x60 - 12"x24"

**03079** | Materia Tensegrity Opal Nat/Ret

\* formato modulare con 60x60 e 30x60 / modular size, can be matched with 60x60 and 30x60 size /  
modulares, sprich mit dem Format 60x60 und 30x60 kombinierbares Format / format modulaire pouvant être coordonné au format 60x60 et 30x60

Pezzi speciali  
Special pieces



Battiscopa 4,5x60 ± 9,5

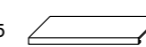

Gradino Costa Retta 30x119,5 ± 9,5

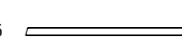

Bacchetta Jolly 1,5x119,5 ± 9,5

↳ Unghia Jolly 1,5x1,5 ± 9,5





# Nacre



± 9,5

\*60x119,5 - 24"x47½"

**02861** | Materia Nacre Nat/Ret  
**02867** | Materia Nacre Lap/Ret



± 9,5

60x60 - 24"x24"

**02848** | Materia Nacre Nat/Ret  
**02854** | Materia Nacre Lap/Ret



± 9,5

60x60 - 24"x24"

**02980** | Materia Gold Nat/Ret  
(mix 4 graphics)



± 9,5

\*30x119,5 - 12"x47½"

**02944** | Materia Raku Warm Nat/Ret  
(handcrafted decor)



± 9,5

30x60 - 12"x24"

**02828** | Materia Nacre Nat/Ret  
**02836** | Materia Nacre Lap/Ret



± 9,5

30x60 - 12"x24"

**02937** | Materia Garage Nacre Nat/Ret



± 9,5

30x60 - 12"x24"

**03081** | Materia Tensegrity Nacre Nat/Ret

\* formato modulare con 60x60 e 30x60 / modular size, can be matched with 60x60 and 30x60 size /  
modulares, sprich mit dem Format 60x60 und 30x60 kombinierbares Format / format modulaire pouvant être coordonné au format 60x60 et 30x60

Pezzi speciali  
Special pieces



Battiscopa 4,5x60 ± 9,5

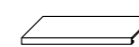

Gradino Costa Retta 30x119,5 ± 9,5

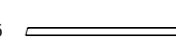

Bacchetta Jolly 1,5x119,5 ± 9,5

↳ Unghia Jolly 1,5x1,5 ± 9,5



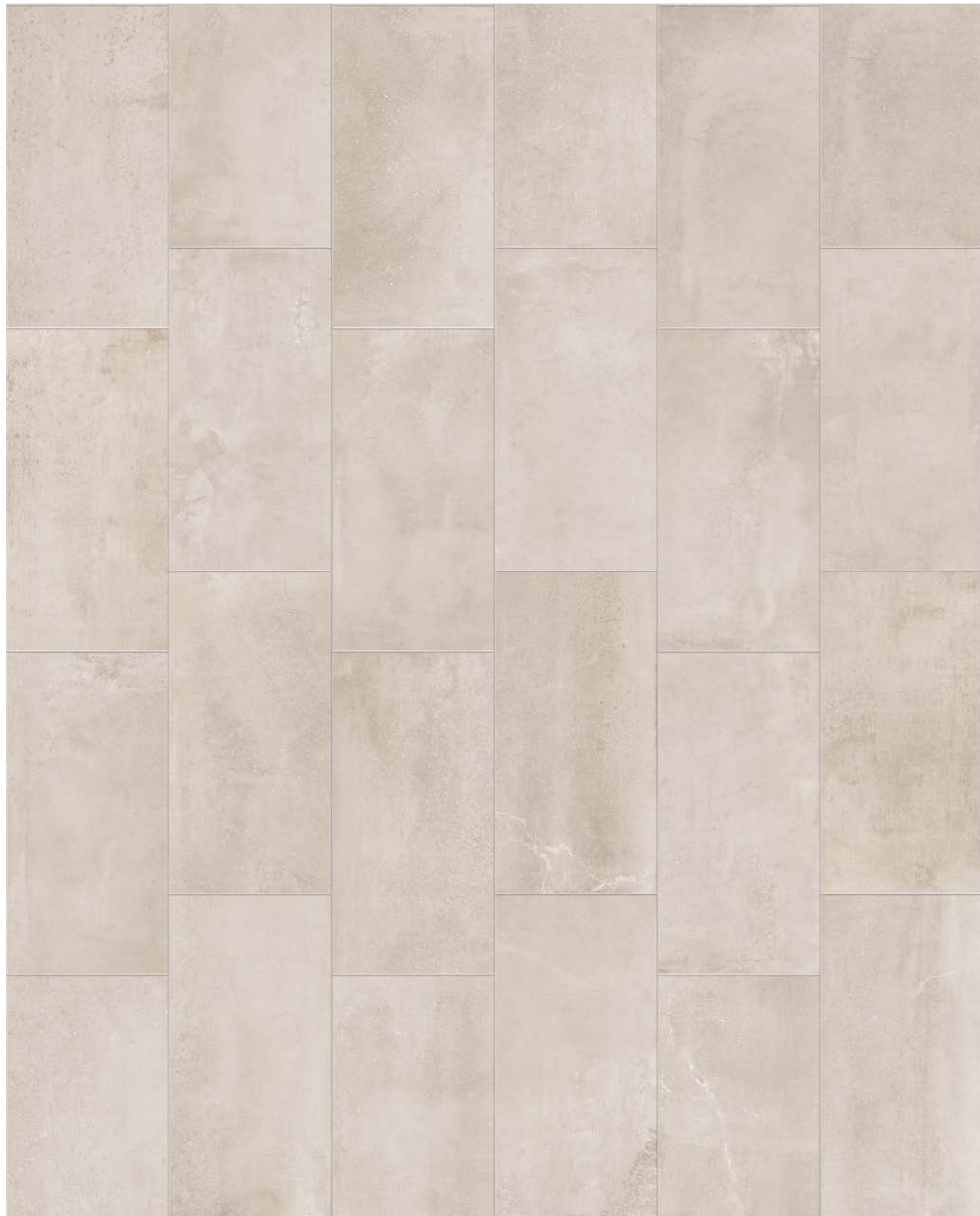

# Shimmer



± 9

119,5x119,5 - 47½"x47½"

**03072** | Materia Shimmer Nat/Ret  
**03076** | Materia Shimmer Lap/Ret



± 20

90x90 - 36"x36"

**02982** | Materia Shimmer Grip/Ret



± 9,5

30x60 - 12"x24"

**02829** | Materia Shimmer Nat/Ret  
**02838** | Materia Shimmer Lap/Ret



± 9,5

30x60 - 12"x24"

**02938** | Materia Garage Shimmer Nat/Ret



± 9,5

60x60 - 24"x24"

**02849** | Materia Shimmer Nat/Ret  
**02855** | Materia Shimmer Lap/Ret



± 9,5

30x60 - 12"x24"

**03082** | Materia Tensegrity Shimmer Nat/Ret



± 9,5

\*60x119,5 - 24"x47½"

**02862** | Materia Shimmer Nat/Ret  
**02868** | Materia Shimmer Lap/Ret



± 9,5

20x15 - 8"x6"

**02989** | Soul Kaleido Light Nat/Ret





± 9,5

\*30x119,5 - 12"x47½"

**02944** | Materia Raku Warm Nat/Ret  
(handcrafted decor)

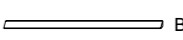
\* formato modulare con 60x60 e 30x60 / modular size, can be matched with 60x60 and 30x60 size /  
modulares, sprich mit dem Format 60x60 und 30x60 kombinierbares Format / format modulaire pouvant être coordonné au format 60x60 et 30x60

Pezzi speciali / Special pieces  Battiscopa 4,5x60 ± 9,5  Gradino Costa Retta 30x119,5 ± 9,5  Bacchetta Jolly 1,5x119,5 ± 9,5  Unghia Jolly 1,5x1,5 ± 9,5

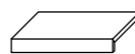
 Elemento L 30x90 ± 20

 Gradone 30x90 ± 20

 Griglia Scolo 18x90 ± 20





Gres fine porcellanato  
Tecnologia Digitale

Fine porcelain stoneware  
Digital Technology

Feinsteinzeug  
Digital Technologie

Grès cérame fin  
Technologie Numérique

# Reflex



± 9,5

\*60x119,5 - 24"x47½"

**02863** | Materia Reflex Nat/Ret  
**02869** | Materia Reflex Lap/Ret



± 20

90x90 - 36"x36"

**02983** | Materia Reflex Grip/Ret



± 9,5

30x60 - 12"x24"

**02831** | Materia Reflex Nat/Ret  
**02841** | Materia Reflex Lap/Ret

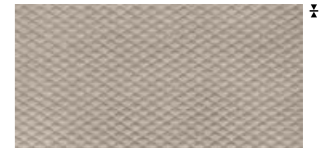

± 9,5

30x60 - 12"x24"

**02939** | Materia Garage Reflex Nat/Ret



± 9,5

\*30x119,5 - 12"x47½"

**02944** | Materia Raku Warm Nat/Ret  
(handcrafted decor)



± 9,5

60x60 - 24"x24"

**02850** | Materia Reflex Nat/Ret  
**02856** | Materia Reflex Lap/Ret



± 9,5

30x60 - 12"x24"

**03083** | Materia Tensegrity Reflex Nat/Ret

\* formato modulare con 60x60 e 30x60 / modular size, can be matched with 60x60 and 30x60 size /  
modulares, sprich mit dem Format 60x60 und 30x60 kombinierbares Format / format modulaire pouvant être coordonné au format 60x60 et 30x60

Pezzi speciali  
Special pieces



Battiscopa 4,5x60 ± 9,5

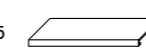

Gradino Costa Retta 30x119,5 ± 9,5

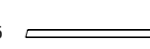

Bacchetta Jolly 1,5x119,5 ± 9,5

4 Unghia Jolly 1,5x1,5 ± 9,5



Elemento L 30x90 ± 20

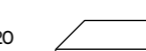

Gradone 30x90 ± 20



Griglia Scolo 18x90 ± 20





# Rust



± 9

119,5x119,5 - 47½"x47½"

**03073** | Materia Rust Nat/Ret  
**03077** | Materia Rust Lap/Ret



± 9,5

60x60 - 24"x24"

**02851** | Materia Rust Nat/Ret  
**02857** | Materia Rust Lap/Ret



± 9,5

60x60 - 24"x24"

**02945** | Materia Jade Nat/Ret  
(mix 4 graphics)



± 9,5

30x60 - 12"x24"

**02832** | Materia Rust Nat/Ret  
**02843** | Materia Rust Lap/Ret



± 9,5

\*60x119,5 - 24"x47½"

**02864** | Materia Rust Nat/Ret  
**02871** | Materia Rust Lap/Ret



± 9,5

30x60 - 12"x24"

**02941** | Materia Garage Rust Nat/Ret



± 9,5

30x60 - 12"x24"

**03084** | Materia Tensegrity Rust Nat/Ret



± 9,5

\*30x119,5 - 12"x47½"

**02944** | Materia Raku Warm Nat/Ret  
(handcrafted decor)



± 9,5

20x15 - 8"x6"

**02990** | Soul Kaleido Dark Nat/Ret

\* formato modulare con 60x60 e 30x60 / modular size, can be matched with 60x60 and 30x60 size /  
modulares, sprich mit dem Format 60x60 und 30x60 kombinierbares Format / format modulaire pouvant être coordonné au format 60x60 et 30x60

Pezzi speciali  
Special pieces



Battiscopa 4,5x60 ± 9,5

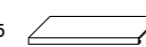

Gradino Costa Retta 30x119,5 ± 9,5

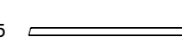

Bacchetta Jolly 1,5x119,5 ± 9,5

Unghia Jolly 1,5x1,5 ± 9,5





# Deep



± 9

119,5x119,5 - 47½"x47½"  
**03074** | Materia Deep Nat/Ret  
**03078** | Materia Deep Lap/Ret



± 20

90x90 - 36"x36"  
**02984** | Materia Deep Grip/Ret



± 9,5

60x60 - 24"x24"  
**02946** | Materia Zaphire Nat/Ret  
(mix 4 graphics)



± 9,5

\*60x119,5 - 24"x47½"  
**02865** | Materia Deep Nat/Ret  
**02872** | Materia Deep Lap/Ret



± 9,5

60x60 - 24"x24"  
**02852** | Materia Deep Nat/Ret  
**02858** | Materia Deep Lap/Ret

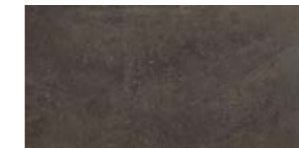

± 9,5

30x60 - 12"x24"  
**02833** | Materia Deep Nat/Ret  
**02846** | Materia Deep Lap/Ret



± 9,5

\*30x119,5 - 12"x47½"  
**02943** | Materia Raku Cold Nat/Ret  
(handcrafted decor)



± 9,5

30x60 - 12"x24"  
**02942** | Materia Garage Deep Nat/Ret



± 9,5

30x60 - 12"x24"  
**03085** | Materia Tensegrity Deep Nat/Ret

\* formato modulare con 60x60 e 30x60 / modular size, can be matched with 60x60 and 30x60 size /  
modulares, sprich mit dem Format 60x60 und 30x60 kombinierbares Format / format modulaire pouvant être coordonné au format 60x60 et 30x60

Pezzi speciali Special pieces Battiscopa 4,5x60 ± 9,5 Gradino Costa Retta 30x119,5 ± 9,5 Bacchetta Jolly 1,5x119,5 ± 9,5 Unghia Jolly 1,5x1,5 ± 9,5

Elemento L 30x90 ± 20 Gradone 30x90 ± 20 Griglia Scolo 18x90 ± 20



# Fasce di Prezzo

■ Fascia prezzo al metro quadro  
Square meter price range  
Quadratmeter preisgruppe  
Niveau de prix au mètre carré

▲ Fascia prezzo al pezzo  
Price range per piece  
Stück preisgruppe  
Niveau de prix à la piece

Price range  
Preisgruppe  
Niveau de prix

| Formati<br>Sizes |                         |                  |                     |                  |                  | Din 51130        | Din 51097 | Dcof |       |       |  |
|------------------|-------------------------|------------------|---------------------|------------------|------------------|------------------|-----------|------|-------|-------|--|
|                  | 119,5x119,5 - 47¼"x47¼" | 90x90 - 36"x36"  | 60x119,5 - 24"x47¼" | 60x60 - 24"x24"  | 30x60 - 12"x24"  |                  |           |      |       |       |  |
|                  | € 9                     | € 20             | € 9,5               | € 9,5            | € 9,5            |                  |           |      |       |       |  |
| Opal             | Nat/Ret                 | 03071 <b>790</b> |                     | 02859 <b>740</b> | 02847 <b>550</b> | 02827 <b>500</b> | V2        | R10  | A+B   | >0.42 |  |
|                  | Lap/Ret                 | 03075 <b>830</b> |                     | 02866 <b>780</b> | 02853 <b>670</b> | 02834 <b>630</b> |           |      |       |       |  |
| Nacre            | Nat/Ret                 |                  |                     | 02861 <b>740</b> | 02848 <b>550</b> | 02828 <b>500</b> | V2        | R10  | A+B   | >0.42 |  |
|                  | Lap/Ret                 |                  |                     | 02867 <b>780</b> | 02854 <b>670</b> | 02836 <b>630</b> |           |      |       |       |  |
| Shimmer          | Nat/Ret                 | 03072 <b>790</b> |                     | 02862 <b>740</b> | 02849 <b>550</b> | 02829 <b>500</b> | V2        | R10  | A+B   | >0.42 |  |
|                  | Lap/Ret                 | 03076 <b>830</b> |                     | 02868 <b>780</b> | 02855 <b>670</b> | 02838 <b>630</b> |           |      |       |       |  |
|                  | Grip/Ret                |                  | 02982 <b>820</b>    |                  |                  |                  |           | R11  | A+B+C | >0.42 |  |
| Reflex           | Nat/Ret                 |                  |                     | 02863 <b>740</b> | 02850 <b>550</b> | 02831 <b>500</b> | V2        | R10  | A+B   | >0.42 |  |
|                  | Lap/Ret                 |                  |                     | 02869 <b>780</b> | 02856 <b>670</b> | 02841 <b>630</b> |           |      |       |       |  |
|                  | Grip/Ret                |                  | 02983 <b>820</b>    |                  |                  |                  |           | R11  | A+B+C | >0.42 |  |
| Rust             | Nat/Ret                 | 03073 <b>790</b> |                     | 02864 <b>750</b> | 02851 <b>580</b> | 02832 <b>530</b> | V2        | R10  | A+B   | >0.42 |  |
|                  | Lap/Ret                 | 03077 <b>830</b> |                     | 02871 <b>790</b> | 02857 <b>690</b> | 02843 <b>650</b> |           |      |       |       |  |
| Deep             | Nat/Ret                 | 03074 <b>790</b> |                     | 02865 <b>750</b> | 02852 <b>580</b> | 02833 <b>530</b> | V2        | R10  | A+B   | >0.42 |  |
|                  | Lap/Ret                 | 03078 <b>830</b> |                     | 02872 <b>790</b> | 02858 <b>690</b> | 02846 <b>650</b> |           |      |       |       |  |
|                  | Grip/Ret                |                  | 02984 <b>820</b>    |                  |                  |                  |           | R11  | A+B+C | >0.42 |  |

# Fasce di Prezzo

■ Fascia prezzo al metro quadro  
Square meter price range  
Quadratmeter preisgruppe  
Niveau de prix au mètre carré

▲ Fascia prezzo al pezzo  
Price range per piece  
Stück preisgruppe  
Niveau de prix à la piece

Price range  
Preisgruppe  
Niveau de prix

| Formati<br>Sizes | Strutture 3D<br>3D Structures |                           |                             |                         |                         |                            |                             |                          |
|------------------|-------------------------------|---------------------------|-----------------------------|-------------------------|-------------------------|----------------------------|-----------------------------|--------------------------|
|                  | Tensegrity<br>30x60 - 12"x24" | Garage<br>30x60 - 12"x24" | Platinum<br>60x60 - 24"x24" | Gold<br>60x60 - 24"x24" | Jade<br>60x60 - 24"x24" | Zaphire<br>60x60 - 24"x24" | Raku<br>30x119,5 - 12"x47¼" | Kaleido<br>20x15 - 8"x6" |
|                  | € 9,5                         | € 9,5                     | € 9,5                       | € 9,5                   | € 9,5                   | € 9,5                      | € 9,5                       |                          |
| Opal             | Nat/Ret                       | 03079 <b>560</b>          | 02936 <b>560</b>            |                         |                         |                            | 02944 <b>861</b>            | 02943 <b>861</b>         |
|                  | Lap/Ret                       |                           |                             |                         |                         |                            |                             |                          |
| Nacre            | Nat/Ret                       | 03081 <b>560</b>          | 02937 <b>560</b>            |                         |                         | 02980 <b>730</b>           | 02944 <b>861</b>            |                          |
|                  | Lap/Ret                       |                           |                             |                         |                         |                            |                             |                          |
| Shimmer          | Nat/Ret                       | 03082 <b>560</b>          | 02938 <b>560</b>            |                         |                         |                            | 02944 <b>861</b>            | 02989 <b>150</b>         |
|                  | Lap/Ret                       |                           |                             |                         |                         |                            |                             |                          |
| Reflex           | Nat/Ret                       | 03083 <b>560</b>          | 02939 <b>560</b>            |                         |                         |                            | 02944 <b>861</b>            |                          |
|                  | Lap/Ret                       |                           |                             |                         |                         |                            |                             |                          |
| Rust             | Nat/Ret                       | 03084 <b>590</b>          | 02941 <b>590</b>            |                         |                         | 02945 <b>730</b>           | 02944 <b>861</b>            | 02990 <b>150</b>         |
|                  | Lap/Ret                       |                           |                             |                         |                         |                            |                             |                          |
| Deep             | Nat/Ret                       | 03085 <b>590</b>          | 02942 <b>590</b>            |                         |                         | 02946 <b>730</b>           | 02943 <b>861</b>            |                          |
|                  | Lap/Ret                       |                           |                             |                         |                         |                            |                             |                          |
|                  | Grip/Ret                      |                           |                             |                         |                         |                            |                             |                          |



# Fasce di Prezzo

Price range  
Preisgruppe  
Niveau de prix

■ Fascia prezzo al metro quadro  
Square meter price range  
Quadratmeter preisgruppe  
Niveau de prix au mètre carré

▲ Fascia prezzo al pezzo  
Price range per piece  
Stück preisgruppe  
Niveau de prix à la piece

|                  |                                  | Pezzi Speciali<br>Special Pieces           |                                |  |                                 |                            |                               |                                  |
|------------------|----------------------------------|--|--------------------------------|--|---------------------------------|----------------------------|-------------------------------|----------------------------------|
|                  |                                  |  |                                |  |                                 |                            |                               |                                  |
|                  |                                  | Gradino Costa Retta<br>30*119,5 - 12"*47½" | Battiscopa<br>4,5*60 - 1¼"*24" | Bacchetta Jolly<br>1,5*119,5 - ¾"*47½" | Unghia Jolly<br>1,5*1,5 - ¼"*¾" | Gradone<br>30*90 - 12"*36" | Elemento L<br>30*90 - 12"*36" | Griglia Scolo<br>18*90 - 7½"*36" |
|                  |                                  | ₪ 9,5                                      | ₪ 9,5                          | ₪ 9,5                                  | ₪ 9,5                           | ₪ 20                       | ₪ 20                          | ₪ 20                             |
| Formati<br>Sizes | Pezzi Speciali<br>Special Pieces |  |                                |  |                                 |                            |                               |                                  |
|                  |                                  |  |                                |  |                                 |                            |                               |                                  |
| Opal             | Nat/Ret                          | 03097 ▲840                                 | 02893 ▲50                      | 03111 ▲370                             | 03124 ▲150                      |                            |                               |                                  |
|                  | Lap/Ret                          | 03104 ▲850                                 | 02899 ▲120                     | 03117 ▲390                             | 03131 ▲170                      |                            |                               |                                  |
| Nacre            | Nat/Ret                          | 03098 ▲840                                 | 02894 ▲50                      | 03112 ▲370                             | 03125 ▲150                      |                            |                               |                                  |
|                  | Lap/Ret                          | 03105 ▲850                                 | 02901 ▲120                     | 03118 ▲390                             | 03132 ▲170                      |                            |                               |                                  |
| Shimmer          | Nat/Ret                          | 03099 ▲840                                 | 02895 ▲50                      | 03113 ▲370                             | 03126 ▲150                      |                            |                               |                                  |
|                  | Lap/Ret                          | 03106 ▲850                                 | 02902 ▲120                     | 03119 ▲390                             | 03133 ▲170                      |                            |                               |                                  |
|                  | Grip/Ret                         |  |                                |  |                                 | 03137 ▲830                 | 03141 ▲840                    | 03149 ▲861                       |
| Reflex           | Nat/Ret                          | 03101 ▲840                                 | 02896 ▲50                      | 03114 ▲370                             | 03127 ▲150                      |                            |                               |                                  |
|                  | Lap/Ret                          | 03107 ▲850                                 | 02903 ▲120                     | 03121 ▲390                             | 03134 ▲170                      |                            |                               |                                  |
|                  | Grip/Ret                         |  |                                |  |                                 | 03138 ▲830                 | 03142 ▲840                    | 03151 ▲861                       |
| Rust             | Nat/Ret                          | 03102 ▲840                                 | 02897 ▲50                      | 03115 ▲370                             | 03128 ▲150                      |                            |                               |                                  |
|                  | Lap/Ret                          | 03108 ▲850                                 | 02904 ▲120                     | 03122 ▲390                             | 03135 ▲170                      |                            |                               |                                  |
| Deep             | Nat/Ret                          | 03103 ▲840                                 | 02898 ▲50                      | 03116 ▲370                             | 03129 ▲150                      |                            |                               |                                  |
|                  | Lap/Ret                          | 03109 ▲850                                 | 02905 ▲120                     | 03123 ▲390                             | 03136 ▲170                      |                            |                               |                                  |
|                  | Grip/Ret                         |  |                                |  |                                 | 03139 ▲830                 | 03143 ▲840                    | 03152 ▲861                       |

# Imballi

Packing  
Verpackung  
Emballage

| Formati<br>Sizes   | Pezzi Speciali<br>Special Pieces | ₪ MM |  |   |  |  |  |   |   |
|--|----------------------------------|------|--|---|--|--|--|---|---|
|  |                                  |      | Pezzi Scatola<br>Pieces/Box<br>Stck/Karton<br>Carreaux/Boite | Mq/Scatola<br>Sqmt/Box<br>Qm/Karton<br>M2/Boite | Kg/Scatola<br>Kgs/Box<br>Kg/Karton<br>Kg/Boite | Scatole/Paletta<br>Boxes/Pallet<br>Karton/Palette<br>Boite/Palette | Mq/Paletta<br>Sqmt/Pallet<br>Qm/Pallet<br>M2/Palette | Kg/Paletta<br>Kgs/Pallet<br>Kg/Pallet<br>Kg/Palette | Formato Paletta<br>Size Pallet<br>Format Pallet<br>Dim. Palette |
| 119,5*119,5 (47½"*47½")<br>Nat/Ret                           | P                                | 9    | 2  | 2,86  | 55,50  | 22   | 62,92  | 1221  | 132x132x53  |
| 119,5*119,5 (47½"*47½")<br>Lap/Ret                           | P                                | 9    | 2  | 2,86  | 55,50  | 22   | 62,92  | 1221  | 132x132x53  |
| 90*90 (36"*36")<br>Grip/Ret                                  | P                                | 20   | 1  | 0,81  | 36,50  | 30   | 24,3   | 1095  | 94x94x105   |
| 60*119,5 (24"*47½")<br>Nat/Ret                               | P                                | 9,5  | 2  | 1,434   | 31,00  | 30   | 43,02  | 930   | 120x80x75   |
| 60*119,5 (24"*47½")<br>Lap/Ret                               | P                                | 9,5  | 2  | 1,434   | 32,00  | 30   | 43,02  | 960   | 120x80x75   |
| 60*60 (24"*24")<br>Nat/Ret                                   | P                                | 9,5  | 3  | 1,08  | 21,50  | 40   | 43,2   | 860   | 120x80x75   |
| 60*60 (24"*24")<br>Lap/Ret                                   | P                                | 9,5  | 3  | 1,08  | 22,50  | 40   | 43,2   | 900   | 120x80x75   |
| 30*60 (12"*24")<br>Nat/Ret                                   | P                                | 9,5  | 6  | 1,08  | 21,50  | 48   | 51,84  | 1032  | 120x80x75   |
| 30*60 (12"*24")<br>Lap/Ret                                   | P                                | 9,5  | 6  | 1,08  | 22,50  | 48   | 51,84  | 1080  | 120x80x75   |
| 30*119,5 (12"*47½")<br>Raku Nat/Ret                          | P                                | 9,5  | 2  | 0,717   | 15,50  | 30   | 21,51  | 465   | 120x80x45   |
| 60*60 (24"*24")<br>Jade - Zaphire - Gold - Platinum Nat/Ret  | P                                | 9,5  | 2  | 0,72  | 14,50  | 32   | 23,04  | 464   | 120x80x75   |
| 30*60 (12"*24")<br>Garage Nat/Ret                            | P                                | 9,5  | 6  | 1,08  | 21,50  | 40   | 43,2   | 860   | 120x80x75   |
| 30*60 (12"*24")<br>Tensegrity Nat/Ret                        | P                                | 9,5  | 6  | 1,08  | 21,50  | 40   | 43,2   | 860   | 120x80x75   |
| 20*15 (8"*6")<br>Kaleido Nat/Ret                             | P                                | 9,5  | 25   | 0,750   | 15,50  | 36   | -  | -   | -   |
| Pezzi Speciali / Special Pieces                              |                                  |      |  |   |  |  |  |   |   |
| 30*119,5 (12"*47½")<br>Gradino Costa Retta Nat/Ret - Lap/Ret | P                                | 9,5  | 2  | 0,717   | 17,00  | 20   | -  | -   | -   |
| 4,5*60 (1¼"*24")<br>Battiscopa Nat/Ret - Lap/Ret             | P                                | 9,5  | 14   | 0,378<br>m.l. 8,40                              | 8,00   | 80   | -  | -   | -   |
| 1,5*119,5 (¾"*47½")<br>Bacchetta Jolly Nat/Ret - Lap/Ret     | P                                | 9,5  | 6  | 0,108   | 2,50   | 48   | -  | -   | -   |
| 1,5*1,5 (¾"*¾")<br>Unghia Jolly Nat/Ret - Lap/Ret            | P                                | 9,5  | 6  | 0,001   | 0,50   | 48   | -  | -   | -   |
| 30*90 (12"*36")<br>Gradone Grip/Ret                          | P                                | 20   | 2  | 0,54  | 24,50  | 36   | -  | -   | -   |
| 30*90 (12"*36")<br>Elemento L Grip/Ret                       | P                                | 20   | 2  | 0,54  | 28,50  | 27   | -  | -   | -   |
| 18*90 (7½"*36")<br>Griglia Scolo Grip/Ret                    | P                                | 20   | 1  | 0,162   | 7,50   | 48   | -  | -   | -   |



## Pezzi Speciali

Special pieces  
Formstücke  
Pièces spéciales

Battiscopa Nat/Ret 4,5×60 – 1¼"×24" ± 9,5  
Battiscopa Lap/Ret 4,5×60 – 1¼"×24" ± 9,5

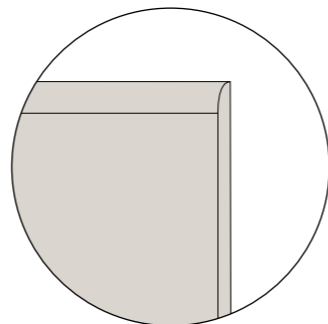
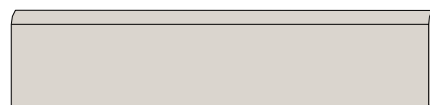

Gradino Costa Retta Nat/Ret 30×119,5 – 12"×47½" ± 9,5  
Gradino Costa Retta Lap/Ret 30×119,5 – 12"×47½" ± 9,5  
(costa retta ottenuto per taglio e incollaggio - obtained by cutting and gluing)

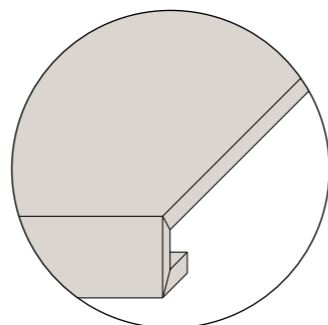
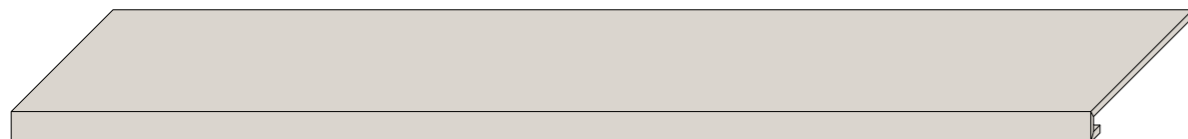

Elemento L 20 mm Grip/Ret 30×90 – 12"×36" ± 20  
(ottenuto per taglio e incollaggio - obtained by cutting and gluing)

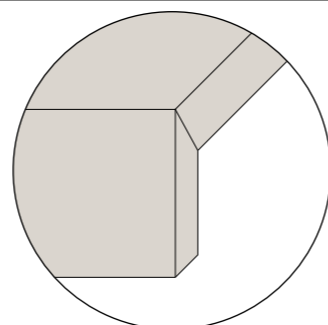

Gradone 20 mm Grip/Ret 30×90 – 12"×36" ± 20  
(toro tecnico - full bullnose edge)

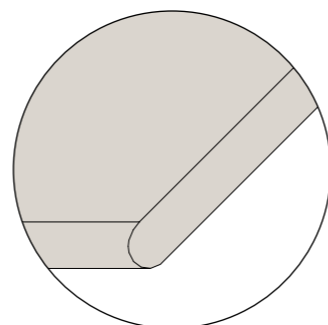
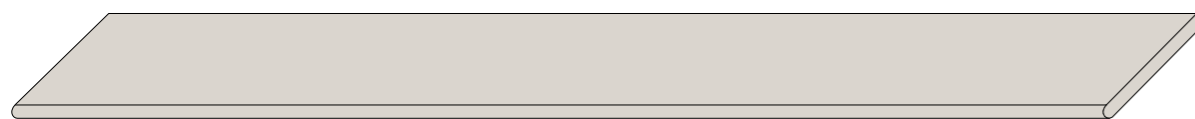

Griglia Scolo 20 mm Grip/Ret 18×90 – 7½"×36" ± 20  
(ottenuto per taglio e incollaggio - obtained by cutting and gluing)

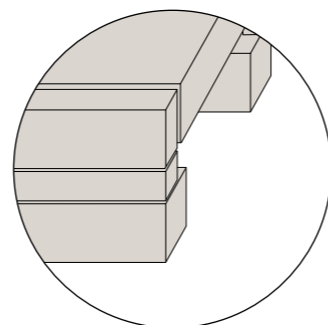
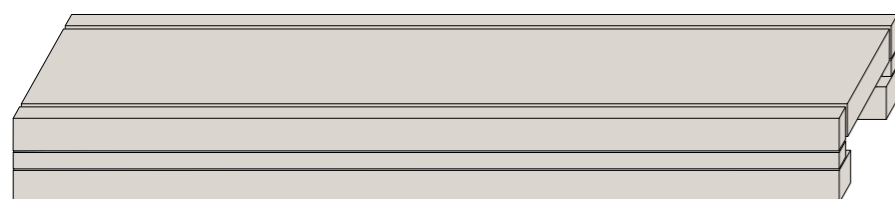

## Pezzi Speciali

Special pieces  
Formstücke  
Pièces spéciales

Bacchetta Jolly Nat/Ret 1,5×119,5 – ⅝"×47½" ± 9,5  
Bacchetta Jolly Lap/Ret 1,5×119,5 – ⅝"×47½" ± 9,5

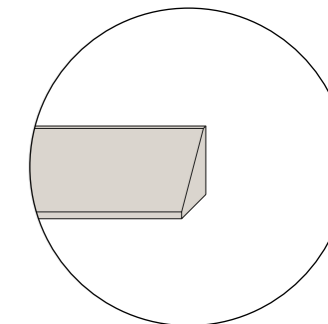
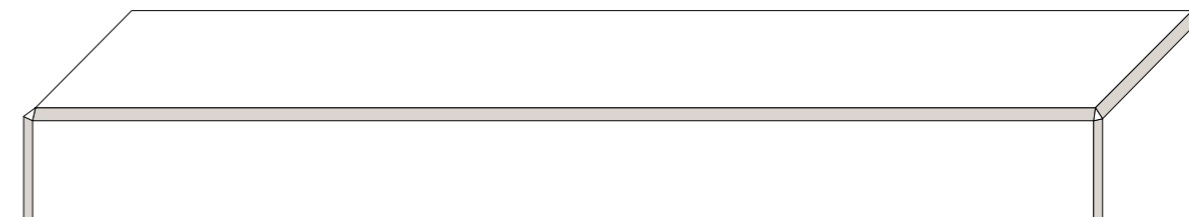

Unghia Jolly Nat/Ret 1,5×1,5 – ⅝"×⅝" ± 9,5  
Unghia Jolly Lap/Ret 1,5×1,5 – ⅝"×⅝" ± 9,5

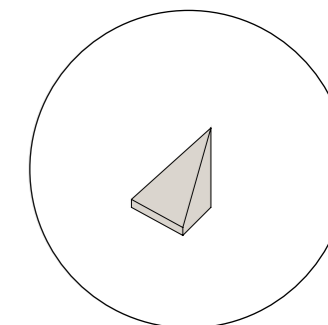
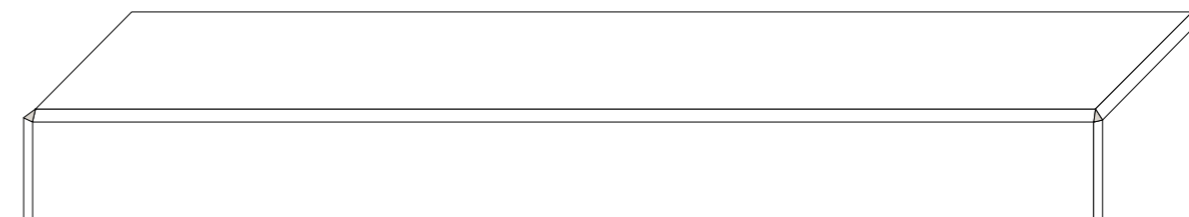

## Elementi di Raccordo Bacchetta e Unghia Jolly

Universal Bevel Filler Strip and Corner Filler Chip  
Verbindungselemente Universalleiste und -aussenecke  
Éléments de raccord baguette et onglet Jolly



Angoli Muretti / Wall Bevel Corners /  
Ecke für Zwischenwände / Angles murets



Spigoli Scale / Staircase Bevel Edge /  
Kanten für Treppen / Arêtes escaliers



# Pezzi Speciali su Richiesta

Special pieces upon request  
Formstücke auf Anfrage  
Pièces spéciales sur demande

Gradone Angolare Sx/Dx 20 mm Grip/Ret 30x90 – 12”x36” ± 20  
(toro tecnico - full bullnose edge)

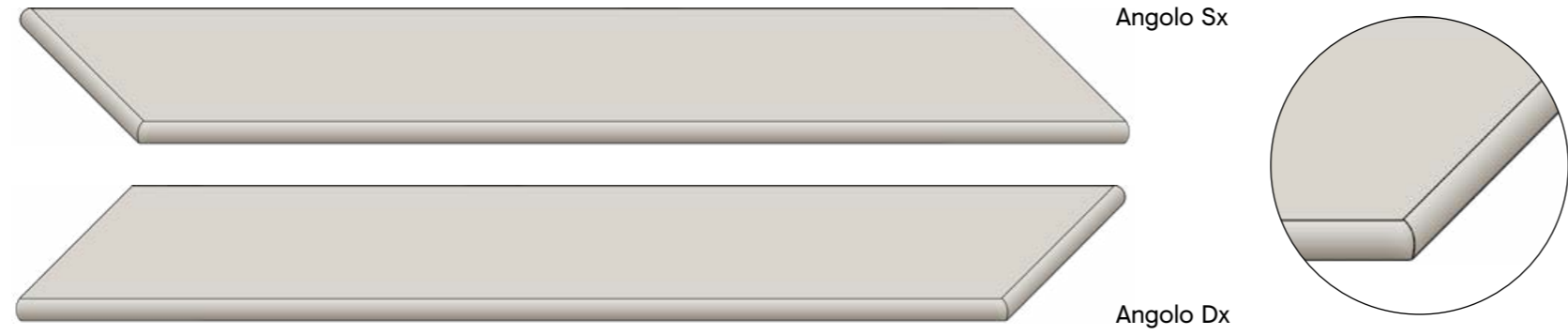

Griglia Scolo Angolare Sx/Dx 20 mm Grip/Ret 18x90 – 7 1/4”x36” ± 20  
(ottenuto per taglio e incollaggio - obtained by cutting and gluing)

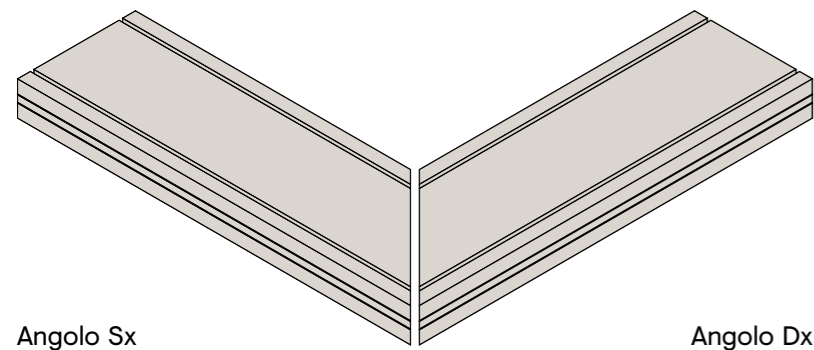

# Caratteristiche Tecniche

Technical characteristics  
Technische daten  
Caracteristiques techniques

CLASSIFICAZIONE SECONDO NORME CEN/ISO GRUPPO B1A EN 14411 - ISO 13006 - CLASSIFICATION IN ACCORDANCE WITH CEN/ISO STANDARDS B1A EN 14411 - ISO 13006  
KLASSIFIZIERUNG GEMÄSS CEN/ISO-NORMEN GRUPPE B1A EN 14411 - ISO 13006 - CLASSIFICATION SELON LES NORMES CEN/ISO GROUPE B1A EN 14411 - ISO 13006

| CARATTERISTICA TECNICA<br>TECHNICAL CHARACTERISTIC<br>TECHNISCHE DATE<br>CARACTÉRISTIQUE TECHNIQUE   | NORMA<br>NORM<br>NORM<br>NORME | VALORE PRESCRITTO<br>VALUE REQUIRED<br>NORMVORGABE<br>VALEUR PRESCRIPTE   | VALORE MEDIO<br>MEAN VALUE<br>MITTELWERT<br>VALEUR MOYENNE | USA TESTS<br>                                      | VALORE MEDIO<br>MEAN VALUE<br>MITTELWERT<br>VALEUR MOYENNE |
|--|--------------------------------|---|--|--|--|
|  |                                |   | CERAMICHE PIEMME<br>FLOOR AND MORE                         |  | CERAMICHE PIEMME<br>FLOOR AND MORE                         |
| LUNGHEZZA E LARGHEZZA<br>LENGHT AND WIDTH / LÄNGE UND BREITE / LONGUEUR ET LARGEUR   |                                | ±0.6% (±2.00 MM)  |  |  |  |
| SPESORE<br>THICKNESS / STÄRKE / ÉPAISSEUR  |                                | ±5% (±0.5 MM)   |  |  |  |
| RETILINEITÀ LATI<br>WARPAGES OF EDGES / GERADHEIT DER KANTEN / RÉCITUDE DES ARÊTES   | ISO 10545.2                    | ±0.5% (±1.5 MM)   | CONFORME<br>IN ACCORDANCE<br>ERFÜLLT<br>CONFORME           | ASTM C-499<br>ASTM C-485<br>ASTM C-502             | IN ACCORDANCE  |
| ORTOGONALITÀ<br>WEDGING / RECHTWINKLIGKEIT / ORTHOGONALITÉ   |                                | ±0.5% (±2.00 MM)  |  |  |  |
| PLANARITÀ<br>FLATNESS / PLANITÄT / PLANIMÉTRIE   |                                | ±0.5% (±2.00 MM)  |  |  |  |
| ASSORBIMENTO % D'ACQUA<br>WATER ABSORPTION<br>WASSERAUFNAHME %<br>ABSORPTION D'EAU %   | ISO 10545.3                    | ≤ 0.5%  | CONFORME<br>IN ACCORDANCE<br>ERFÜLLT<br>CONFORME           | ASTM C-373   | IN ACCORDANCE  |
| RESISTENZA ALLA FLESSIONE<br>BENDING STRENGTH<br>BIEGEZUGFESTIGKEIT<br>RÉSISTANCE À LA FLEXION   | ISO 10545.4                    | ≥ 35N/MM²   | CONFORME<br>IN ACCORDANCE<br>ERFÜLLT<br>CONFORME           | ASTM C-648<br>250 LBS OR GREATER                   | IN ACCORDANCE  |
| DILATAZIONE TERMICA LINEARE TRA 20° E 100° C<br>LINEAR THERMAL EXPANSION BETWEEN 20° AND 100° C<br>LINEARE WÄRMEAUSSDEHNUNG ZWISCHEN 20° UND 100° C<br>DILATATION THERMIQUE LINEAIRE ENTRE 20° ET 100° C | ISO 10545.8                    | SECONDO I DATI DEL COSTRUTTORE<br>ACCORDING TO BUILDERS SPECIFICATIONS<br>LAUT ANGABEN DES HERSTELLERS<br>SELON LES ELEMENTS DU COSTRUCTEUR | ≈ 7X10 <sup>-6</sup> C <sup>-1</sup>                       |  |  |
| RESISTENZA AGLI SBALZI TERMICI<br>THERMAL SHOCK RESISTANCE<br>TEMPERATURWECHSELBESTÄNDIGKEIT<br>RÉSISTANCE AUX ÉCARTS DE TEMPÉRATURE   | ISO 10545.9                    | RICHIESTA<br>REQUEST<br>BITTE<br>DEMANDE  | RESISTENTE<br>RESISTANT<br>WIDERSTEHEND<br>RÉSISTANT       |  |  |
| RESISTENZA AL GELO<br>FROST RESISTANCE<br>FROSTBESTÄNDIGKEIT<br>RÉSISTANCE AU GEL  | ISO 10545.12                   | RICHIESTA<br>REQUEST<br>BITTE<br>DEMANDE  | RESISTENTE<br>RESISTANT<br>WIDERSTEHEND<br>RÉSISTANT       | ASTM C-1026  | IN ACCORDANCE  |
| RESISTENZA ALL'ATTACCO CHIMICO<br>RESISTANCE TO CHEMICAL ATTACK<br>BESTÄNDIGKEIT GEGEN CHEMIKALIEN<br>RÉSISTANCE À L'ATTAQUE CHIMIQUE  | ISO 10545.13                   | SECONDO I DATI DEL COSTRUTTORE<br>ACCORDING TO BUILDERS SPECIFICATIONS<br>LAUT ANGABEN DES HERSTELLERS<br>SELON LES ELEMENTS DU COSTRUCTEUR | RESISTENTE<br>RESISTANT<br>WIDERSTEHEND<br>RÉSISTANT       | ASTM C-650   | IN ACCORDANCE  |
| RESISTENZA DEI COLORI ALLA LUCE<br>COLOURS RESISTANCE TO LIGHT<br>LICHTBESTÄNDIGKEIT<br>RÉSISTANCE DES COULEURS À LA LUMIÈRE   | DIN 51094                      | NESSUNA ALTERAZIONE<br>NO ALTERATION<br>KEINE VERÄNDERUNG<br>AUCUNE ALTERATION  | CONFORME<br>IN ACCORDANCE<br>ERFÜLLT<br>CONFORME           |  |  |
| RESISTENZA ALLE MACCHIE<br>STAIN RESISTANCE<br>FLECKENFESTIGKEIT<br>RÉSISTANCE AUX TACHES  | ISO 10545.14                   | ≥ CLASSE 3<br>METODO DI PROVA DISPONIBILE<br>TEST METHOD AVAILABLE<br>VERFÜGBARE PRÜFMETHODE<br>METHODE D'ESSAI DISPONIBILE                 | CONFORME<br>IN ACCORDANCE<br>ERFÜLLT<br>CONFORME           |  |  |
| RESISTENZA ALLO SCIVOLAMENTO<br>SLIP/PADE RESISTANCE<br>RUTSCHSICHERHEIT<br>RÉSISTANCE AU GLISSEMENT   | DIN 51130 *                    | 9 ≤ R ≤ 13  | NAT<br>LAP<br>GRIP 20MM                                    | R10<br>ASTM C-1028 * COF<br>≥ 0.6 DRY<br>≥ 0.6 WET | NAT<br>LAP<br>GRIP 20MM                                    |
|  | DIN 51097 *                    | A,B,C   | NAT<br>LAP<br>GRIP 20MM                                    | A+B<br>ANSI *<br>137.1-2012 DCOF<br>> 0.42 WET     | NAT<br>LAP<br>GRIP 20MM                                    |
|  | BS EN 7976-2*                  | > 36 DRY<br>> 36 WET  | NAT<br>LAP<br>GRIP 20MM                                    |  | NAT<br>LAP<br>GRIP 20MM                                    |

\*TRATTANDOSI DI NORMATIVE NAZIONALI, I METODI DI PROVA, I REQUISITI E LE CLASSIFICAZIONI VARIANO DA PAESE A PAESE. IL VALORE ATTESO DALLA RESISTENZA ALLO SCIVOLAMENTO DELLA PRODUZIONE DI INDUSTRIE CERAMICHE PIEMME S.P.A., PUÒ VARIARE IN BASE AL LOTTO PRODUTTIVO. SPECIFICA DOCUMENTAZIONE È DISPONIBILE SU RICHIESTA.  
TEST METHODS, REQUIREMENTS AND CLASSIFICATIONS DIFFER FROM COUNTRY TO COUNTRY, ACCORDING TO THE NATIONAL REGULATIONS. THE EXPECTED VALUE OF SLIPPAGE RESISTANCE OF PRODUCTS BY INDUSTRIE CERAMICHE PIEMME S.P.A. MAY VARY DEPENDING ON THE PRODUCTION BATCH. SPECIFIC DOCUMENTS ARE AVAILABLE UPON REQUEST.  
PRÜFVERFAHREN, ERFORDERNISSE UND KLASSIFIKATIONEN SIND VERSCHIEDEN VON LAND ZU LAND, GEMÄSS DER NATIONALEN VORSCHRIFTEN. DER ERWARTUNGSWERT DER RUTSCHSICHERHEIT DER PRODUKTE VON INDUSTRIE CERAMICHE PIEMME S.P.A. KANN SICH - JE NACH DER PRODUKTIONSPARTIE - VERÄNDERN. SPEZIFISCHE UNTERLAGEN SIND AUF VERLANGEN ZUR VERFÜGUNG.  
LES MÉTHODES D'ESSAI, LES RÉQUISITIONS ET LES CLASSIFICATIONS CHANGENT DE PAYS À PAYS, SELON LES RÉGLEMENTATIONS NATIONALES. LA VALEUR ATTENDUE DE RÉSISTANCE AU GLISSEMENT DES PRODUITS DE INDUSTRIE CERAMICHE PIEMME S.P.A. PEUT VARIER EN FONCTION DU LOT DE PRODUCTION. UNE DOCUMENTATION SPÉCIFIQUE EST DISPONIBLE SUR DEMANDE.

ELENCO DELLE SERIE CERTIFICATE E CLASSIFICAZIONI DISPONIBILI A RICHIESTA - LIST OF CERTIFIED SERIES AND CLASSIFICATIONS AVAILABLE UPON REQUEST  
LISTE DER GEPRÜFTEN SERIE UND KLASSIFIZIERUNGEN AUF ANFRAGE ERHÄLTLIICH - LISTE DES SERIES CERTIFIÉES ET DES CLASSEMENTS DISPONIBLES SUR DEMANDE



CERAMICHE PIEMME  
FLOOR AND MORE





# Norme per la posa e la manutenzione

Installation and maintenance instructions

Verlegung, reiningung und pflege

Guide a la pose et l'entretien

For better installation results of rectified products, we suggest 2 mm joint.

For a better aesthetic finish, Piemme recommends using jointing colours that match the tiles.

Please check, before using, the compatibility and suitability of grouting material with the ceramic tile.

Clean away the excess of grouting materials while they are still fresh.

Follow carefully the instructions pointed out by the producers of tile grouting materials.

To completely eliminate installation residues, which could negatively affect routine maintenance and product characteristics once installation has terminated, proceed to clean using adequate products, with max. 3% Acid base, following the manufacturer’s instructions. Always closely abide by the time limits indicated in the instructions: prolonged contact with these products may cause damage to the surface.

Any rims that appear after installing lapped or polished materials can be easily eliminated using a suitable Alkaline-based product.

With regard to the use of ceramic materials outdoors, while once more reiterating that Piemme porcelain stoneware products are frost-proof, in compliance with applicable European standards EN 14411/ISO 13006-ISO 10545.12, a number of fundamental procedures must be followed for outdoor installation, suitable for making the aforementioned floors resistant to frost. The most important aspects are: suitable gradients, waterproofing, expansion joints, and the use of suitable installation materials.

Decorations made with glazes and precious metals It is most important to protect the surface during installation. Never use abrasive and/or acid products, only water and neutral soap. The manufacturer disclaims liability in case of any damage to these precious materials caused by “rubbing” during installation. Under no circumstances will disputes be accepted relating to the installed material.

For further specific details please visit the technical area on Piemme website: [www.ceramichepiemme.it](http://www.ceramichepiemme.it)

VERSCHMUTZUNGSART

Bier, Wein, Eis, Kaffee Tierische oder pflanzliche Fette Gummi, Kleberbandresten Schmieröl, Tinte, Leöl, Filzstift, Harz oder Lack, Haarfarbe

Kratzenschutz-Wachs, Kalkablagerunge, Rostflecken

Kerzenwachs Kleberbandresten

Weitere Einzelheiten finden Sie in dem technischen Bereich des Piemme website: [www.ceramichepiemme.it](http://www.ceramichepiemme.it)

TYPE DE TACHE

Bière, Vin, Glace, Café, Graisses végétales et animales, Encres, Résidus de scotch, Huile de graissage, Hile de lin Crayon feutre Émaux, Teinture pour cheveux, Caoutchouc pour pneus

Cire de protection anti abrasion, Dépôts de calcaire, Tache de rouille

Cire de bougie Résidus de scotch

Pour d'ultérieures Information spécifiques consulter le département technique du site Piemme: [www.ceramichepiemme.it](http://www.ceramichepiemme.it)

Pour obtenir le meilleur résultat de pose de produits rectifiés, il est conseillé de réaliser un joint de 2 mm.

Pour parfaire l'effet esthétique obtenu, Piemme conseille de confectionner des joints de la même couleur que les carreaux.

Vérifier avant la pose la compatibilité et convenance des remplissages pour joints avec le produit céramique.

Enlever les surplus des remplissages pour joints alors qu'ils sont encore frais.

Respecter scrupuleusement les instructions indiquées par les fabricants de remplissages pour joints.

Zur vollkommenen Entfernung der Verlegerückstände, die die normale Pflege erschweren und die Merkmale des Produkts beeinträchtigen könnten, nach der Verlegung geeignete Reinigungsmittel auf max. 3% Säurebasis verwenden und bei der Reini gung die Hinweise des Herstellers beachten. Die angegebenen Zeiten keinesfalls überschreiten: ein zu lange andauernder Kontakt mit diesen Produkten kann Beschädigungen der Oberfläche verursachen.

Eventuelle nach der Verlegung von geläpptem oder geschliffenem Material sichtbare Schleier lassen sich einfach mit entsprechenden, alkalischen Produkten entfernen.

Auch wenn die Piemme-Feinsteinzeugprodukte gemäß den europäischen Normen EN 14411/ISO 13006-ISO 10545.12 frostbeständig sind, müssen beim Einsatz keramischer Materialien im Freien einige Grundregeln beachtet werden, damit die Bodenbeläge nicht vom Frost angegriffen werden können. Die wichtigsten Voraussetzungen sind: korrektes Gefälle, Abdichtung, Dehnungsfugen sowie geeignetes Verlegematerial.

Dekore mit Glasuren und Edelmetallen Während der Verlegung muss die Oberfläche unbedingt abgedeckt werden. Es dürfen keine scheuernden und/oder säurehaltigen Produkte verwendet werden, sondern ausschließlich Wasser und neutrale Seife. Der Hersteller haftet nicht für eventuelle, während der Verlegung durch Abrieb entstandene Schäden an diesen hochwertigen Materialien. Reklamationen von bereits verlegtem Material werden in keinem Fall akzeptiert.

Per i prodotti rettificati consigliamo una fuga di 2 mm per un migliore risultato di posa.

Per una migliore resa estetica Piemme consiglia stuccature colorate in tinta con le piastrelle. Verificare, prima dell'utilizzo, la compatibilità ed idoneità dei riempitivi per fughe con il prodotto ceramico.

Rimuovere le eccedenze dei riempitivi per fughe quando gli stessi sono ancora freschi.

Attenersi scrupolosamente alle istruzioni indicate dai produttori dei riempitivi per fughe.

Gli eventuali aloni che si dovessero presentare dopo la posa di materiali lappati o levigati si potranno facilmente eliminare utilizzando un prodotto idoneo, a base Alcalina.

Decorazioni realizzati con smalti e metalli preziosi è indispensabile proteggere la superficie durante la posa, non utilizzare assolutamente prodotti abrasivi e/o acidi, ma solo acqua e sapone neutro. Il produttore non risponde di eventuali danni a questi preziosi materiali causati da "sfregamenti" durante la posa in opera. Per nessun motivo saranno accettate contestazioni relative a materialeposato.

Per ulteriori informazioni specifiche consultare l'area tecnica sul sito Piemme: [www.ceramichepiemme.it](http://www.ceramichepiemme.it)

TIPO DI SPORCO

Birra, Caffè, Gelato, Vino Gomma Pneumatico, Grassi vegetali e animali, Inchiostri, Lampostil Olii Meccanici, Residui di scotch Olio di lino, PennarelloResine Smalti, Tintura per capelli

Cera protettiva anti-abrasione, Depositi calcarei, Macchie di ruggine

Cera di candela, Residui di scotch

Per ulteriori informazioni specifiche consultare l'area tecnica sul sito Piemme: [www.ceramichepiemme.it](http://www.ceramichepiemme.it)

TYPE OF STAIN

beer, coffee, wine, ice cream vegetable and animal fats, rubber, remains of scotch tape, grease from machines, linseed oil, felt tip pens, paints, inks, hair dye

protective anti-abrasion wax, calcareous residuals, rust stains

candle wax, remains of scotch-tape

For further specific details please visit the technical area on Piemme website: [www.ceramichepiemme.it](http://www.ceramichepiemme.it)

VERSCHMUTZUNGSART

Bier, Wein, Eis, Kaffee Tierische oder pflanzliche Fette Gummi, Kleberbandresten Schmieröl, Tinte, Leöl, Filzstift, Harz oder Lack, Haarfarbe

Kratzenschutz-Wachs, Kalkablagerunge, Rostflecken

Kerzenwachs Kleberbandresten

Weitere Einzelheiten finden Sie in dem technischen Bereich des Piemme website: [www.ceramichepiemme.it](http://www.ceramichepiemme.it)

TYPE DE TACHE

Bière, Vin, Glace, Café, Graisses végétales et animales, Encres, Résidus de scotch, Huile de graissage, Hile de lin Crayon feutre Émaux, Teinture pour cheveux, Caoutchouc pour pneus

Cire de protection anti abrasion, Dépôts de calcaire, Tache de rouille

Cire de bougie Résidus de scotch

Pour d'ultérieures Information spécifiques consulter le département technique du site Piemme: [www.ceramichepiemme.it](http://www.ceramichepiemme.it)

TIPO DI SPORCO

Birra, Caffè, Gelato, Vino Gomma Pneumatico, Grassi vegetali e animali, Inchiostri, Lampostil Olii Meccanici, Residui di scotch Olio di lino, PennarelloResine Smalti, Tintura per capelli

Cera protettiva anti-abrasione, Depositi calcarei, Macchie di ruggine

Cera di candela, Residui di scotch

Per ulteriori informazioni specifiche consultare l'area tecnica sul sito Piemme: [www.ceramichepiemme.it](http://www.ceramichepiemme.it)

TYPE OF STAIN

beer, coffee, wine, ice cream vegetable and animal fats, rubber, remains of scotch tape, grease from machines, linseed oil, felt tip pens, paints, inks, hair dye

protective anti-abrasion wax, calcareous residuals, rust stains

candle wax, remains of scotch-tape

For further specific details please visit the technical area on Piemme website: [www.ceramichepiemme.it](http://www.ceramichepiemme.it)

VERSCHMUTZUNGSART

Bier, Wein, Eis, Kaffee Tierische oder pflanzliche Fette Gummi, Kleberbandresten Schmieröl, Tinte, Leöl, Filzstift, Harz oder Lack, Haarfarbe

Kratzenschutz-Wachs, Kalkablagerunge, Rostflecken

Kerzenwachs Kleberbandresten

Weitere Einzelheiten finden Sie in dem technischen Bereich des Piemme website: [www.ceramichepiemme.it](http://www.ceramichepiemme.it)

TYPE DE TACHE

Bière, Vin, Glace, Café, Graisses végétales et animales, Encres, Résidus de scotch, Huile de graissage, Hile de lin Crayon feutre Émaux, Teinture pour cheveux, Caoutchouc pour pneus

Cire de protection anti abrasion, Dépôts de calcaire, Tache de rouille

Cire de bougie Résidus de scotch

Pour d'ultérieures Information spécifiques consulter le département technique du site Piemme: [www.ceramichepiemme.it](http://www.ceramichepiemme.it)

# Guida alla Lettura

Reading Guide

Leseanleitung

Guide à la lecture

For better installation results of rectified products, we suggest 2 mm joint.

For a better aesthetic finish, Piemme recommends using jointing colours that match the tiles.

Please check, before using, the compatibility and suitability of grouting material with the ceramic tile.

Clean away the excess of grouting materials while they are still fresh.

Follow carefully the instructions pointed out by the producers of tile grouting materials.

To completely eliminate installation residues, which could negatively affect routine maintenance and product characteristics once installation has terminated, proceed to clean using adequate products, with max. 3% Acid base, following the manufacturer’s instructions. Always closely abide by the time limits indicated in the instructions: prolonged contact with these products may cause damage to the surface.

Any rims that appear after installing lapped or polished materials can be easily eliminated using a suitable Alkaline-based product.

With regard to the use of ceramic materials outdoors, while once more reiterating that Piemme porcelain stoneware products are frost-proof, in compliance with applicable European standards EN 14411/ISO 13006-ISO 10545.12, a number of fundamental procedures must be followed for outdoor installation, suitable for making the aforementioned floors resistant to frost. The most important aspects are: suitable gradients, waterproofing, expansion joints, and the use of suitable installation materials.

Decorations made with glazes and precious metals It is most important to protect the surface during installation. Never use abrasive and/or acid products, only water and neutral soap. The manufacturer disclaims liability in case of any damage to these precious materials caused by “rubbing” during installation. Under no circumstances will disputes be accepted relating to the installed material.

For further specific details please visit the technical area on Piemme website: [www.ceramichepiemme.it](http://www.ceramichepiemme.it)

TIPO DI SPORCO

Birra, Caffè, Gelato, Vino Gomma Pneumatico, Grassi vegetali e animali, Inchiostri, Lampostil Olii Meccanici, Residui di scotch Olio di lino, PennarelloResine Smalti, Tintura per capelli

Cera protettiva anti-abrasione, Depositi calcarei, Macchie di ruggine

Cera di candela, Residui di scotch

Per ulteriori informazioni specifiche consultare l'area tecnica sul sito Piemme: [www.ceramichepiemme.it](http://www.ceramichepiemme.it)

TYPE OF STAIN

beer, coffee, wine, ice cream vegetable and animal fats, rubber, remains of scotch tape, grease from machines, linseed oil, felt tip pens, paints, inks, hair dye

protective anti-abrasion wax, calcareous residuals, rust stains

candle wax, remains of scotch-tape

For further specific details please visit the technical area on Piemme website: [www.ceramichepiemme.it](http://www.ceramichepiemme.it)

VERSCHMUTZUNGSART

Bier, Wein, Eis, Kaffee Tierische oder pflanzliche Fette Gummi, Kleberbandresten Schmieröl, Tinte, Leöl, Filzstift, Harz oder Lack, Haarfarbe

Kratzenschutz-Wachs, Kalkablagerunge, Rostflecken

Kerzenwachs Kleberbandresten

Weitere Einzelheiten finden Sie in dem technischen Bereich des Piemme website: [www.ceramichepiemme.it](http://www.ceramichepiemme.it)

TYPE DE TACHE

Bière, Vin, Glace, Café, Graisses végétales et animales, Encres, Résidus de scotch, Huile de graissage, Hile de lin Crayon feutre Émaux, Teinture pour cheveux, Caoutchouc pour pneus

Cire de protection anti abrasion, Dépôts de calcaire, Tache de rouille

Cire de bougie Résidus de scotch

TIPO DI SPORCO

Birra, Caffè, Gelato, Vino Gomma Pneumatico, Grassi vegetali e animali, Inchiostri, Lampostil Olii Meccanici, Residui di scotch Olio di lino, PennarelloResine Smalti, Tintura per capelli

Cera protettiva anti-abrasione, Depositi calcarei, Macchie di ruggine

Cera di candela, Residui di scotch

Per ulteriori informazioni specifiche consultare l'area tecnica sul sito Piemme: [www.ceramichepiemme.it](http://www.ceramichepiemme.it)

TYPE OF STAIN

beer, coffee, wine, ice cream vegetable and animal fats, rubber, remains of scotch tape, grease from machines, linseed oil, felt tip pens, paints, inks, hair dye

protective anti-abrasion wax, calcareous residuals, rust stains

candle wax, remains of scotch-tape

For further specific details please visit the technical area on Piemme website: [www.ceramichepiemme.it](http://www.ceramichepiemme.it)

VERSCHMUTZUNGSART

Bier, Wein, Eis, Kaffee Tierische oder pflanzliche Fette Gummi, Kleberbandresten Schmieröl, Tinte, Leöl, Filzstift, Harz oder Lack, Haarfarbe

Kratzenschutz-Wachs, Kalkablagerunge, Rostflecken

Kerzenwachs Kleberbandresten

Weitere Einzelheiten finden Sie in dem technischen Bereich des Piemme website: [www.ceramichepiemme.it](http://www.ceramichepiemme.it)

TYPE DE TACHE

Bière, Vin, Glace, Café, Graisses végétales et animales, Encres, Résidus de scotch, Huile de graissage, Hile de lin Crayon feutre Émaux, Teinture pour cheveux, Caoutchouc pour pneus

Cire de protection anti abrasion, Dépôts de calcaire, Tache de rouille

Cire de bougie Résidus de scotch

Pour d'ultérieures Information spécifiques consulter le département technique du site Piemme: [www.ceramichepiemme.it](http://www.ceramichepiemme.it)

Spessore Thickness Stärke Epaisseur

Fascia prezzo al metro quadrato Square meter price range Quadratmeter preisgruppe Niveau de prix au mètre carré

Fascia prezzo al pezzo Price range per piece Stück preisgruppe Niveau de prix à la pièce

Tutti i formati sono nominali.

Gli spessori riportati in questo catalogo sono nominali e possono variare a seconda dei formati e delle finiture.

I colori e le caratteristiche estetiche dei prodotti sono quanto più possibile vicini a quelli reali, nei limiti consentiti dai processi di stampa.

Reading Guide

Leseanleitung

Guide à la lecture

For better installation results of rectified products, we suggest 2 mm joint.

For a better aesthetic finish, Piemme recommends using jointing colours that match the tiles.

Please check, before using, the compatibility and suitability of grouting material with the ceramic tile.

Clean away the excess of grouting materials while they are still fresh.

Follow carefully the instructions pointed out by the producers of tile grouting materials.

To completely eliminate installation residues, which could negatively affect routine maintenance and product characteristics once installation has terminated, proceed to clean using adequate products, with max. 3% Acid base, following the manufacturer’s instructions. Always closely abide by the time limits indicated in the instructions: prolonged contact with these products may cause damage to the surface.

Any rims that appear after installing lapped or polished materials can be easily eliminated using a suitable Alkaline-based product.

With regard to the use of ceramic materials outdoors, while once more reiterating that Piemme porcelain stoneware products are frost-proof, in compliance with applicable European standards EN 14411/ISO 13006-ISO 10545.12, a number of fundamental procedures must be followed for outdoor installation, suitable for making the aforementioned floors resistant to frost. The most important aspects are: suitable gradients, waterproofing, expansion joints, and the use of suitable installation materials.

Decorations made with glazes and precious metals It is most important to protect the surface during installation. Never use abrasive and/or acid products, only water and neutral soap. The manufacturer disclaims liability in case of any damage to these precious materials caused by “rubbing” during installation. Under no circumstances will disputes be accepted relating to the installed material.

For further specific details please visit the technical area on Piemme website: [www.ceramichepiemme.it](http://www.ceramichepiemme.it)

TIPO DI SPORCO

Birra, Caffè, Gelato, Vino Gomma Pneumatico, Grassi vegetali e animali, Inchiostri, Lampostil Olii Meccanici, Residui di scotch Olio di lino, PennarelloResine Smalti, Tintura per capelli

Cera protettiva anti-abrasione, Depositi calcarei, Macchie di ruggine

Cera di candela, Residui di scotch

Per ulteriori informazioni specifiche consultare l'area tecnica sul sito Piemme: [www.ceramichepiemme.it](http://www.ceramichepiemme.it)

TYPE OF STAIN

beer, coffee, wine, ice cream vegetable and animal fats, rubber, remains of scotch tape, grease from machines, linseed oil, felt tip pens, paints, inks, hair dye

protective anti-abrasion wax, calcareous residuals, rust stains

candle wax, remains of scotch-tape

For further specific details please visit the technical area on Piemme website: [www.ceramichepiemme.it](http://www.ceramichepiemme.it)

VERSCHMUTZUNGSART

Bier, Wein, Eis, Kaffee Tierische oder pflanzliche Fette Gummi, Kleberbandresten Schmieröl, Tinte, Leöl, Filzstift, Harz oder Lack, Haarfarbe

Kratzenschutz-Wachs, Kalkablagerunge, Rostflecken

Kerzenwachs Kleberbandresten

Weitere Einzelheiten finden Sie in dem technischen Bereich des Piemme website: [www.ceramichepiemme.it](http://www.ceramichepiemme.it)

TYPE DE TACHE

Bière, Vin, Glace, Café, Graisses végétales et animales, Encres, Résidus de scotch, Huile de graissage, Hile de lin Crayon feutre Émaux, Teinture pour cheveux, Caoutchouc pour pneus

Cire de protection anti abrasion, Dépôts de calcaire, Tache de rouille

Cire de bougie Résidus de scotch

Pour d'ultérieures Information spécifiques consulter le département technique du site Piemme: [www.ceramichepiemme.it](http://www.ceramichepiemme.it)

TIPO DI SPORCO

Birra, Caffè, Gelato, Vino Gomma Pneumatico, Grassi vegetali e animali, Inchiostri, Lampostil Olii Meccanici, Residui di scotch Olio di lino, PennarelloResine Smalti, Tintura per capelli

Cera protettiva anti-abrasione, Depositi calcarei, Macchie di ruggine

Cera di candela, Residui di scotch

Per ulteriori informazioni specifiche consultare l'area tecnica sul sito Piemme: [www.ceramichepiemme.it](http://www.ceramichepiemme.it)

TYPE OF STAIN

beer, coffee, wine, ice cream vegetable and animal fats, rubber, remains of scotch tape, grease from machines, linseed oil, felt tip pens, paints, inks, hair dye

protective anti-abrasion wax, calcareous residuals, rust stains

candle wax, remains of scotch-tape

For further specific details please visit the technical area on Piemme website: [www.ceramichepiemme.it](http://www.ceramichepiemme.it)

VERSCHMUTZUNGSART

Bier, Wein, Eis, Kaffee Tierische oder pflanzliche Fette Gummi, Kleberbandresten Schmieröl, Tinte, Leöl, Filzstift, Harz oder Lack, Haarfarbe

Kratzenschutz-Wachs, Kalkablagerunge, Rostflecken

Kerzenwachs Kleberbandresten

Weitere Einzelheiten finden Sie in dem technischen Bereich des Piemme website: [www.ceramichepiemme.it](http://www.ceramichepiemme.it)

TYPE DE TACHE

Bière, Vin, Glace, Café, Graisses végétales et animales, Encres, Résidus de scotch, Huile de graissage, Hile de lin Crayon feutre Émaux, Teinture pour cheveux, Caoutchouc pour pneus

Cire de protection anti abrasion, Dépôts de calcaire, Tache de rouille

Cire de bougie Résidus de scotch

Pour d'ultérieures Information spécifiques consulter le département technique du site Piemme: [www.ceramichepiemme.it](http://www.ceramichepiemme.it)

Spessore Thickness Stärke Epaisseur

Fascia prezzo al metro quadrato Square meter price range Quadratmeter preisgruppe Niveau de prix au mètre carré

Fascia prezzo al pezzo Price range per piece Stück preisgruppe Niveau de prix à la pièce

Tutti i formati sono nominali.

Gli spessori riportati in questo catalogo sono nominali e possono variare a seconda dei formati e delle finiture.

I colori e le caratteristiche estetiche dei prodotti sono quanto più possibile vicini a quelli reali, nei limiti consentiti dai processi di stampa.





Ceramics of Italy rappresenta la volontà dell'industria italiana delle piastrelle di ceramica nel diffondere e promuovere una nuova valenza della piastrella di ceramica: non più solo un prodotto per l'industria delle costruzioni, ma punto di riferimento per stile e creatività per lo sviluppo di una nuova cultura dell'abitare Made in Italy.

Ceramics of Italy represents the willingness of the Italian ceramic tile industry to spread and promote a new concept of ceramic tile: no longer just a product for the construction industry, but a focal point for style and creativity in the development of a new culture of living Made in Italy.



#### Una storia tutta italiana

Piemme dal 1962, anno della sua fondazione, è protagonista indiscussa del vero Made in Italy, quello fatto di eccellenza, passione e creatività. Oggi tutti i materiali Piemme sono prodotti con tecnologia d'avanguardia come la decorazione digitale inkjet HD, la cottura in forni ad energia pulita a recupero di calore, la rettifica e levigatura in linea "one roof" e la verifica elettronica dello standard qualitativo.

#### An all-Italian story

Since 1962, the year of its foundation, Piemme has been the undisputed protagonist of real Made in Italy, that which consists of excellence, passion and creativity. Today, all Piemme materials are made using cuttingedge technology such as HD inkjet digital decoration, firing in heat-recycling cleanenergy kilns, "one roof" grinding and polishing line and electronic quality standard control.

#### Eine ganz italienische Geschichte

Seit dem Gründungsjahr 1962 ist Piemme ein unangefochtener Hauptakteur des echten Made in Italy: jenem, das auf Exzellenz, Leidenschaft und Kreativität gründet. Alle Piemme Erzeugnisse werden heute unter Einsatz von Spitzentechnologie produziert, wie zum Beispiel mit der digitalen Inkjet-Dekoration, dem Brennen in Öfen mit grüner Energie und Wärmerückgewinnung, dem Schleifen und Polieren in der Linie „unter einem Dach“ sowie der elektronischen Prüfung des Qualitätsniveaus.

#### Une histoire toute italienne

Depuis 1962, l'année de sa fondation, Piemme est la protagoniste indiscutée du Made in Italy, basé sur l'excellence, la passion et la créativité. Aujourd'hui toutes les phases du cycle de fabrication Piemme sont issues d'une technologie à l'avant-garde comme la décoration numérique inkjet HD, la cuisson dans des fours à énergie propre et à récupération de chaleur, la rectification et le polissage en en ligne "one roof" et la vérification électronique de la qualité.

# CERAMICHE PIEMME

FLOOR AND MORE

INDUSTRIE CERAMICHE PIEMME S.P.A.  
VIA DEL CROCIALE 42/44, 41042 FIORANO (MO) - ITALY  
T. +39 0536.849111 - F. +39 0536.849402  
WWW.CERAMICHEPIEMME.IT - INFO@CERAMICHEPIEMME.IT