

# RAMMER RO7P



PERFORMANCE LINE

PROVEN TECHNOLOGY

VIBRATION AND SOUND SUPPRESSED

FULLY ENCLOSED, HEAVY DUTY HOUSING

EXCELLENT POWER-TO-WEIGHT RATIO

NITROGEN PISTON ACCUMULATOR

EASY TO SERVICE

## UNBEATABLE PERFORMANCE

The new Rammer Performance Line hammers are your everyday solution for a wide range of breaking demands. Designed with proven Rammer features and standards, these Rammer Performance Line hammers offer more than just excellent power-to-weight ratio, they bring the quality reassurance that only a true Rammer hammer can bring.

Read more about the product from [www.rammer.com](http://www.rammer.com)



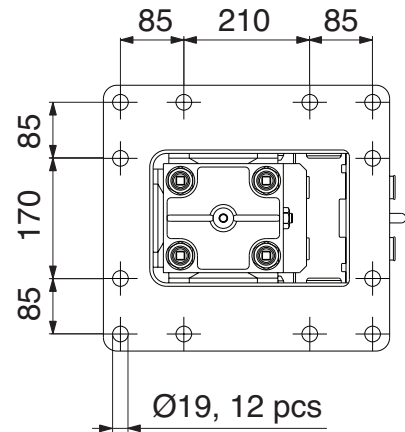
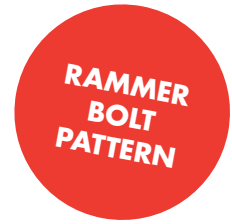
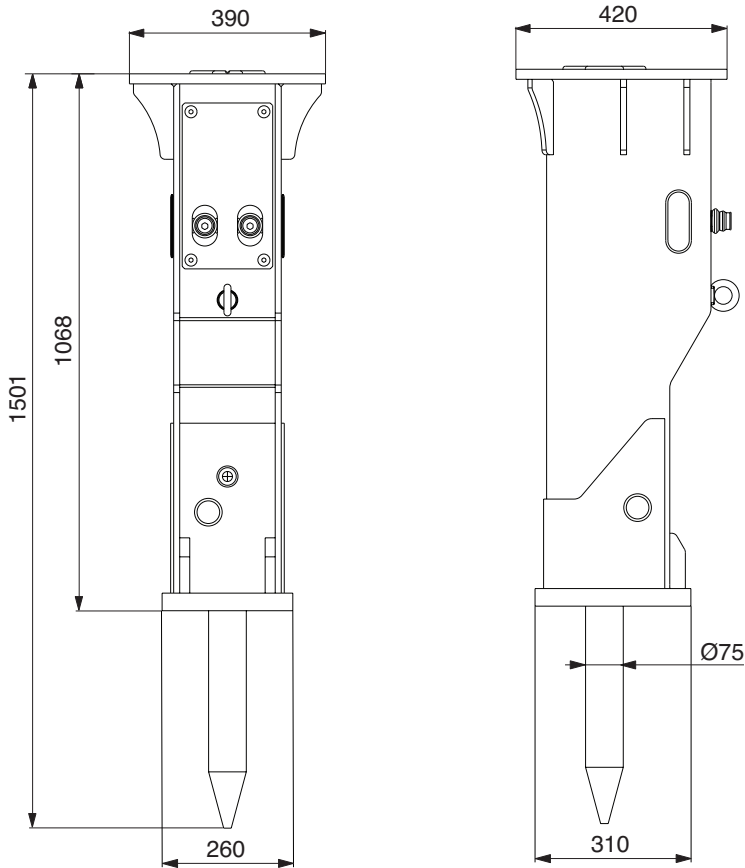

## SPECIFICATIONS

Min. working weight, kg (lb)	410 (904)
Tool diameter, mm (in)	75 (2.95)
Oil flow range, l/min (gal/min)	45 - 90 (12 - 24)
Impact rate, bpm	450 - 950
Operating pressure, bar (psi)	80 - 140 (1 160 - 2 031)
Pressure relief, min, bar (psi)	200 (2 901)
Pressure relief, max, bar (psi)	220 (3 191)
Back pressure, max, bar (psi)	15 (218)
Input power, kW (hp)	21 (28)
Miniexcavator range, ton (lb)	5.0 - 9.0 (11 023 - 19 842)
Skid steer range, ton (lb)	3.5 - 6.0 (7 716 - 13 228)
Noise level measured sound power level, LWA, dB(A)	117
Noise level guaranteed sound power level, LWA, dB(A)	121

## TOOLS



Moil point tool



Chisel tool

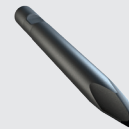

Pyramid tool

Specifications are subject to change without notice

