



CTM-MARINE

CT

High-efficient self-contained marine air conditioners.

**6K - 10k - 12k - 16k - 25K
BTU**



High Velocity Blower



<270° Rotatable Blower



Quiet



Composite Drain Pan



Compact



Cool/Heat



Titanium Condenser Coil



Stainless Steel Frame Base



Universal Board



Re-usable Air Filter



Fire Retardant Electrical Box



Wi-Fi Thermostats

www.ctm-marine.com

Air conditioners for the modern sailor.

Model No.	CT-6	CT-6H	CT-10	CT-10H	CT-12	CT-12H	CT-16	CT-16H	CT-25H
Capacity (BTU)	6,000		10,000		12,000		16,000		25,000
Voltage (V)	100-120	208-240	100-120	208-240	100-120	208-240	100-120	208-240	208-240
Cycle (Hz) / Phase (Ph)	50-60 / 1								
Input: Cool (A)	4.5	2.1	6.7	3.3	8.7	4.3	10.5	5.1	8.5
Input: Heat (A)	5.6	2.7	8.8	3.9	10.8	4.9	13.5	6.6	9.6
Fuse Max/Min (A)	15/10	10/7	25/16	15/10	25/16	15/10	40/25	20/13	30/18
Locked Rotator Amps (A)	35	15	42	22	43	23	60	34	50
Seawater Inlet Connection (in/mm)	5/8 / 16								
Seawater Outlet Connection (in/mm)	5/8 / 16								
Seawater Flow (GPH)	150		250		500		550		
Refrigerant Type	R410A								
Net Weight (lbs/Kg)	41 / 18.60		50 / 22.7		57 / 25.90		87 / 39.4		
Width (W) (in/mm)	15.28 / 388		20 / 508		22.83 / 580				
Height (H) (in/mm)	11.50 / 292		13.25 / 337		14 / 356		15.82 / 402		
Depth (D) (in/mm)	9.50 / 240		12 / 305		13.5 / 343		15 / 380		
Duct Ring (in/mm)	4 / 100		5 / 127		6 / 152		7 / 178		
Min. Return Air Grille (sq in / sq cm)	64 / 413		100 / 646		130 / 839		160 / 1033		248 / 1600
Min. Supply Air Grille (sq in / sq cm)	32 / 206		60 / 388		70 / 452		80 / 517		139 / 900

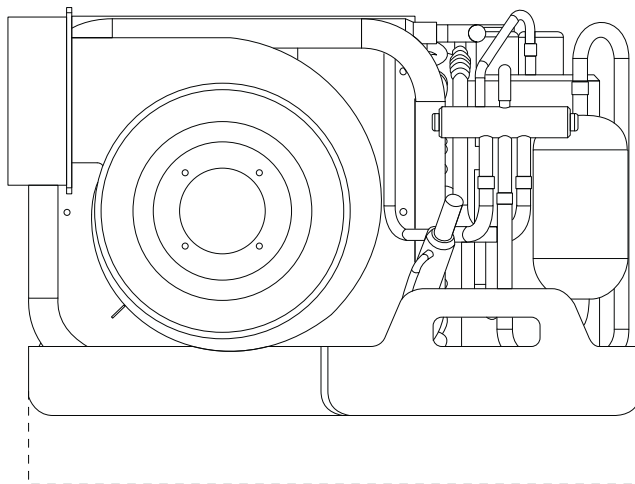

W

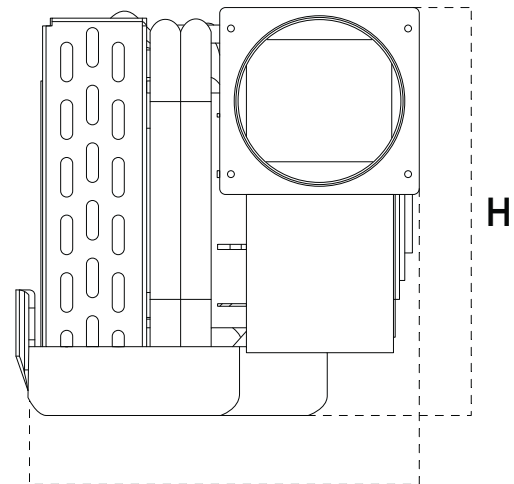

H

D

No part of this document may be reproduced, translated or transmitted in any form or by any means electronic, mechanical, photocopying, recording or otherwise without prior written consent by CTM-Marine.