

cool mate & cuddy dc

Installation & Operation

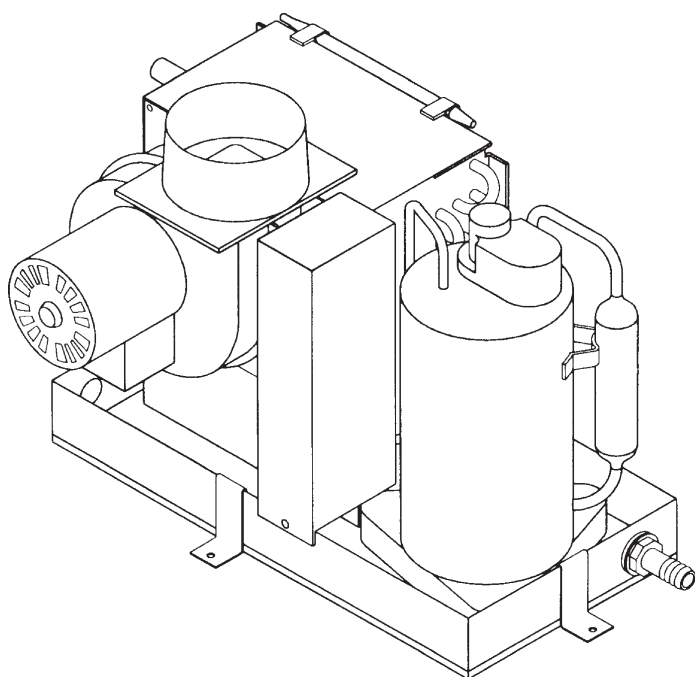

Patent Number 5,848,536



Cool Mate and Cuddy dc
Self-Contained Cooling Only A/C Kits
Revised: 5-11-07
L-2200



TABLE OF CONTENTS

Installation	4
Warning	4
Notice	4
Introduction	4
Cuddy dc	4
Unpacking and Inspection	4
Safety Considerations	5
Placement Of System	5
Tools Required for Installation	5
Spacing Allowances & Unit Dimensions	6
How It Works	6
Mounting Brackets	6
Condensate Drains	6
Blower Assembly	7
Supply & Return Air Grilles and Transition Boxes	7
Ducting	7
Manual Control Panel Installation	7
Electrical Connections, Grounding & Bonding for AC Powered Cool Mate	7
Electrical Connections, Grounding & Bonding for DC Powered Cuddy dc	8
Electrical System and Wiring for DC Powered Cuddy dc	8
Notice and ABYC Standards	9
Seawater Pump and Plumbing	9
Installation Checklist (review prior to and after installation)	10
Operation	11
Operation	11
Troubleshooting Guidelines	11
Maintenance	13
Seawater Strainer	13
Condenser Coil Cleaning	13
Return Air Filters	13
Winterization	13
Manufacturers Limited Warranty Agreement	14
Description of Figures	15
Distributor Listing	28

INSTALLATION

Warning

This manual contains essential safety information concerning the safe and proper installation and operation of Cool Mate and Cuddy dc self-contained direct expansion air conditioners. It is very important that you read and understand the contents of this manual thoroughly before attempting to install any Marine Air equipment. If there are any statements in this manual that you do not understand, contact the Dometic Environmental Corporation Applications Department for assistance. Phone (804) 746-1313, Fax (804) 746-7248 (8:00am - 5:00pm United States Eastern Time).

Notice

As of July 1, 1992, United States federal law prohibits the intentional release of refrigerant gases into the environment, including the R-22 refrigerant mostly used in Marine Air air conditioning systems. Special care must be taken when installing, charging and servicing Marine Air equipment to prevent any loss of refrigerant.

Marine Air does not recommend the practice of using refrigerant to purge air and moisture from the system at installation. This formerly used practice of purging is in violation of United States federal law.

Introduction

You have just purchased the first complete built-in marine air conditioning system designed for self installation. We are confident you will find the added comforts experienced in your boat to be well worth the money spent. If, upon opening your new system, you discover any parts are missing, contact your dealer immediately.

Before attempting to install your new Cool Mate (AC powered) or Cuddy dc (DC powered) air conditioning system, you must read this installation manual completely. Failure to perform certain tasks in the proper sequence could result in an inoperative system as well as a voided warranty.

Cuddy dc

The new **Cuddy dc** marine air conditioner is very similar to the standard Zephyr but is unique in one way—it is designed to be run on 12VDC battery power. Most of the installation, operation and maintenance information in this manual applies to both types of air conditioners, the AC voltage Cool Mate and the DC voltage Cuddy dc. Installation of either unit is nearly identical with the exception of the power supply and how that power is connected to the unit, control and pump. With that in mind while reading this manual, please read the Installation, Operation, and Maintenance sections titled “Cool

Mate and Cuddy dc Units”, and especially the sections subtitled “for DC Powered Cuddy dc”. Cuddy dc owners may skip the sections that are subtitled “for AC Powered Cool Mate.”

Cuddy dc kits contain the air conditioning unit and these three components: a Dedicated Power Module (DPM), a 2-knob mechanical control, and the water pump. Each of these components is connected to the a/c unit with a polarized plug. These plugs are configured unique to each component. The DPM is sized to run the Cuddy dc system only and should not be used for any other appliance(s). See Figure 11 in the back of this manual for DPM specifications.

! WARNING The DPM is not ignition protected and must not be installed in the engine compartment or in any area with flammable or compressed gasses or liquids (see the Safety Considerations section of this manual for more information).

Dometic recommends using a separate battery bank dedicated to run the **Cuddy dc**. For specific instructions, please see the two sections in this manual titled “Electrical System and Wiring for DC Powered Cuddy dc” and “Electrical Connections, Grounding & Bonding for DC Powered Cuddy dc.”

! WARNING The compressor and fan on the **Cuddy dc** air conditioning unit are **AC voltage components, running on 115VAC** supplied by the DPM. The pump and 2-knob mechanical control also run on 115VAC supplied by the DPM. Once the DPM is connected to the dedicated 12VDC battery bank, then all necessary power distribution to each of the components is handled through the polarized plugs - truly a “plug & play” system.

Unpacking and Inspection

When the equipment is received, all items should be carefully checked against the packing list to ensure all cartons have been received. Move units in the normal “up” orientation as indicated by the arrows on each carton. Examine cartons for shipping damage, removing the units from the cartons if necessary. If the unit is damaged, the carrier should make the proper notation on the delivery receipt acknowledging the damage.

CAUTION: When unpacking and installing the control, care must be taken not to kink or break the copper cap tube when uncoiling the sensing bulb. The cap tube is hollow and kinking or sharp bends will inhibit system operation.

Safety Considerations

Never install your air conditioner in the bilge or engine room areas. Insure that the selected location is sealed from direct access to bilge and/or engine room vapors. Do not terminate condensate drain line within three (3) feet of any outlet of engine or generator exhaust systems, nor in a compartment housing an engine or generator, nor in a bilge, unless the drain is connected properly to a sealed condensate or shower sump pump. Failure to comply may allow bilge or engine room vapors to mix with the air conditioners return air and contaminate living areas which may result in injury or death.

Consideration should be given to installing a trap in the condensate drain line(s) so that normal discharge of condensate can fill the trap and prevent the ingress of carbon monoxide (CO) or other potentially harmful vapors.

Installation and servicing of this system can be hazardous due to system pressure and electrical components. When working on this equipment, always observe precautions described in the literature, tags and labels attached to the unit. Follow all safety codes. Wear safety glasses and work gloves and place a fire extinguisher close to the work area. The following is a summary of the labels on the unit:

! DANGER Electrical shock hazard. Disconnect voltage at main panel or power source before opening any cover. Failure to comply may result in injury or death.

! WARNING This component does not meet Federal requirements for ignition protection. Do not install in spaces containing gasoline engines, tanks, LPG/CPG cylinders, regulators, valves or fuel line fittings. Failure to comply may result in injury or death.

NOTICE This component is charged with hydrochlorofluoro-carbon (HCFC) refrigerant R22. Effective July 1, 1992 it shall be unlawful for any person to knowingly vent or otherwise knowingly release any class 1 (CFC) or class 2 (HCFC) substance as a refrigerant in a manner which permits such substance to enter the atmosphere per the clean air act of 1990. Public law 101-549 Title IV Section 608-c. Failure to comply may result in severe penalties, including fines and imprisonment. Note: The Cuddy dc unit is charged with R417a.

! WARNING To minimize the hazard of electrical shock and personal injury, this component must be effectively grounded. Refer to the installation guidelines for further information.

! WARNING The compressor and fan on the **Cuddy dc** air conditioning unit are **AC voltage components, running on 115VAC** supplied by the DPM. The pump and 2-knob mechanical control also run on 115VAC supplied by the DPM. Disconnect voltage at main panel or power source before opening any cover. Failure to comply may result in injury or death.

Placement Of System

Selecting a good location for your air conditioner is the most important part of your preparations. Be sure to consider the size of the area you are cooling, the air distribution needs, and the size of the unit you have chosen. Keeping in mind that cool air has a tendency to fall, it is highly recommended that you locate the supply air grille as high as possible in the cabin. See the Cool Mate Kit drawings, Figures 14-17, at the back of this manual for examples.

The air conditioning unit should be installed as low as possible, **but never in the bilge or engine room areas. Insure that the selected location is sealed from direct access to bilge and/or engine room vapors.** Installing the unit as low as possible (such as under a V-berth, dinette seat or bottom of a locker) and ducting the supply air as high as possible, creates an ideal air flow condition. This type of installation will prevent short or premature cycling.

The unit should be positioned on a firm, level, horizontal surface and the condensate drain line should run downward from the unit to a suitable drain location. Plan all connections which must be made including ducting, condensate drain, seawater in and out, electrical power connections, location of control, and seawater pump placement, to assure easy access for routing and servicing.

Tools Required for Installation

- Screw drivers
- Pliers
- Pipe wrench
- Wire cutters/crimpers
- Drill & 7/8" bit
- Jig saw
- Duct tape
- Electrical tape
- Teflon tape
- Bedding compound to seal thru hull fittings
- Hardware to secure unit, pump, strainer, grilles & control panel

Spacing Allowances & Unit Dimensions

The following space allowances should be considered when mounting the unit:

1. Allow a minimum of 6" (152mm) around the perimeter of the unit in the area of the seawater and condensate drain piping.
2. Allow a minimum of 3" (76mm) of air space in front of the evaporator coil for the return air intake if it is adjacent to a bulkhead.
3. Allow a minimum of 3" (76mm) of air space for the electric blower motor ventilation. For Cuddy dc systems, allow at least 1" (25mm) above DPM for adequate ventilation.
4. For flexible ducting connection, allow 2" (51mm) for the duct ring, 1" (25mm) for the duct bend radius and add diameter of the ducting to get the total clearance distance (2" [51mm] + 1" [25mm] + duct diameter) as measured from the blower outlet (this also applies to clearance needed behind the supply air grille). Note that the blower and duct ring can be positioned either vertically or horizontally. See Figure 1 at the back of this manual.

These space allowances are suggested minimums. Enough space should be allocated for installation and serviceability. See Figure 1 at the back of this manual for space allowances and unit dimensions.

How It Works

Your self-contained air conditioner consists of four main components and a refrigerant gas circulating through the system. The BLOWER draws warm cabin air across the fins on the EVAPORATOR where the heat from the air is transferred to the refrigerant in the evaporator coil. As the refrigerant evaporates from a liquid into a gas it absorbs the heat from the cabin air. The COMPRESSOR then compresses the refrigerant gas and pumps it through the outer tube in the CONDENSER COIL. The seawater pump circulates cool seawater through the inner tube in the condenser coil, this cools the refrigerant in the outer tube and condenses it from a gas into a liquid. The heat from the refrigerant is exchanged to the seawater and discharged overboard. The liquid refrigerant is then passed through the EVAPORATOR COIL and the cycle repeats. Removing heat from the cabin air lowers its temperature. The cooled air is blown through the ducting and out the supply air grille(s). See Figure 2 at the back of this manual for component identification.

Mounting Brackets

The air conditioning unit is supplied with a base pan that also serves as a condensate pan. Mounting clip brackets and screws (4) are provided to secure the base pan onto a flat, horizontal surface. See Figure 3 at the back of this manual.

Condensate Drains

The condensate drain pan is 1¾" (45mm) high with two drain locations. During conditions of high humidity, condensate may be produced at a rate of approximately ½ gallon (1.9 liter) per hour. With this in mind, it is important to route condensate drains downward to a sump pump. It is not recommended to route condensate drains to the bilge. After the condensate drain installation is complete, test the installation by pouring a quart of water into the pan and checking for good flow.

For installation of the condensate drain (refer to Figure 4 at the back of this manual):

1. Remove the aft facing watertight plug from the base pan of the air conditioning unit.
2. Slip the solid washer and the liquid-seal washer onto the PVC fitting in that order.
3. Connect the fitting through the exposed hole in the base pan with the locking nut.
4. Securely tighten with two (2) wrenches to provide a proper seal.
5. Attach a 5/8" (16mm) I.D. reinforced hose to the hose barb and secure with stainless steel hose clamps.
6. Install the condensate drain hose downhill from the unit and aft to a sump - hose should have a trap.
7. Two drain fittings may be used and the hoses teed together provided there is a minimum 2" drop from the bottom of the base pan to the tee connection.

Note:

Do not terminate condensate drain line within three (3) feet of any outlet of engine or generator exhaust systems, nor in a compartment housing an engine or generator, nor in a bilge, unless the drain is connected properly to a sealed condensate or shower sump pump. Failure to comply may allow bilge or engine room vapors to mix with the air conditioners return air and contaminate living areas which may result in injury or death.

Consideration should be given to installing a trap in the condensate drain line(s) so that normal discharge of condensate can fill the trap and prevent the ingress of carbon monoxide (CO) or other potentially harmful vapors.

Blower Assembly

Horizontal or vertical supply air discharge may be achieved by rotating the blower. Its design allows the blower to be rotated by removing the screws holding the blower plate to the evaporator coil shroud. Rotate the blower to allow the most direct flow of air to the supply air grille. **To rotate the 10-16K blowers, remove the two plastic plugs for access to the mounting screws.**

Supply & Return Air Grilles and Transition Boxes

As previously indicated, install the supply air grille(s) as high as possible and the return air grille as low and close to the air conditioning unit as possible to insure direct uninterrupted airflow to the evaporator. In no instance should the supply air grille discharge be directed towards the return air grille, as this will cause the system to short cycle.

The cut out for the 3" (76mm) round supply air grille for the 3.5K unit is 3" (76mm) in diameter and the flange is 3⁷/₈" (99mm) in diameter. The cut out for the 4" (102mm) round supply air grille for the 5K unit is 4" (102mm) in diameter and the flange is 5¹/₂" (140mm) in diameter. The cut out for the rectangular supply air transition box used with the 10 & 12K units is 11⁵/₈" (295mm) by 5⁵/₈" (148 mm) and for the 16K unit it is 13⁵/₈" (346mm) by 5⁵/₈" (148 mm). Connect the 6" (152mm) or 7" (178mm) oblong duct ring to the transition box by first placing the ring on the box and tracing the hole. Cut the oblong hole out of the box. Secure the ring to the box with rivets (trim 1/4" [6mm] from ring flanges if necessary). Completely seal the joint between ring and box with silicone. A minimum clearance of 3" (76mm) plus the duct diameter size is required behind the grille for attaching the ducting (see earlier section, "*Spacing Allowance and Unit Dimensions*").

The cut outs for the return air grilles are as follows: 7-5/8" (194mm) square for the 3.5K & 5K units, 11-5/8" (295mm) square for the 10K & 12K units, and 13-5/8" (346mm) x 11-5/8" (295mm) (width x height) for the 16K unit. The return air grille should have a minimum of 4" (107mm) of clearance in front of it, free from any furniture or other obstructions. The return air filter, mounted to the front of the evaporator, removes debris from the air prior to the air being drawn across the evaporator coil and fins. Dust and lint can clog and reduce airflow across the evaporator coil resulting in poor performance. See the "*Maintenance*" section for filter cleaning instructions.

Ducting

Good airflow is critical for the performance of the entire system. It is highly dependent on the quality of the ducting installation. The ducting should be run as straight, smooth and taut as possible minimizing the number of 90 degree bends (two tight 90 degree bends can reduce airflow by 25 percent). The following is a summary of proper ducting connections:

1. Pull back the fiberglass insulation exposing the inner mylar duct hose.
2. Slide the mylar duct hose around the mount ring until it bottoms out.
3. Screw 3 or 4 stainless steel sheet metal screws through the duct hose into the transition ring. Make sure to catch the wire in the duct hose with the heads of the screws. Do not use band clamps, as the hose will slide off.
4. Wrap duct tape around the ducting and ring joint to prevent any air leaks.
5. Pull the insulation back up over the mylar to the ring and tape this joint.
6. Remove excess ducting and use the same connection method at the supply air grille.

Manual Control Panel Installation

The manual control panel should be located within cap tube length of the air conditioning unit. The dimensions for the 2-knob panel are 3¹/₄" (83mm) x 5¹/₂" (140mm). The cut out size for the 2-knob panel is 2¹/₂" (64mm) wide by 4³/₄" (121mm) tall. (Refer to Figure 5 at the back of this manual.) Once the cut out is made, carefully uncoil the copper cap tube with return air sensor (copper bulb) and route the control wires and cap tube through the hole and back to the unit **using caution not to kink the cap tube**. Mount the return air sensor into the clips provided on the evaporator coil. If the return air sensor cannot be mounted on the evaporator coil, mount it behind the return air grille. The sensor must be mounted in the return air stream. Make electrical connections according to the wiring diagrams provided. (See wiring diagrams, Figures 7-10 at the back of this manual.)

Electrical Connections, Grounding & Bonding for AC Powered Cool Mate

All Cool Mate units have a five position terminal strip mounted inside the electric box. The terminal strip is labeled for proper connections of the electrical supply, ground wires and pump circuits. Wiring diagrams are provided in the electrical box and in this manual. The correct size circuit breaker should be used to protect the system as specified on the air conditioning unit's data

plate label. A minimum of 12 AWG boat cable should be used to supply power to the air conditioning unit and to the seawater pump (see next paragraph). All connections to the terminal strip shall be made with ring terminals supplied with the Cool Mate kit. **Turn off AC (alternating current) power supply circuit breaker before opening electrical box and accessing the terminal strip.**

Each air conditioning unit installed requires its own dedicated circuit breaker. If there is only one air conditioning unit installed, the seawater pump does not require a circuit breaker; the wiring from the seawater pump is connected to the terminal strip on the unit. (See wiring diagrams, Figures 7-9, at the back of this manual.) A minimum of 12 AWG boat cable should be used to extend the wires on the pump, if necessary, using the butt slices included with the kit. If two or more air conditioning units use the same seawater pump, the pump wires will be connected to a pump relay panel (PRP) which in turn has its own dedicated circuit breaker (see the wiring diagram furnished with the PRP). Any electrical connections in the bilge below the waterline should use heat shrink type butt splices.

The air conditioning unit must be connected to the boat's bonding system to prevent corrosion due to stray electrical current. Ensure that the AC ground of the air conditioning unit is properly connected to the AC ground of the boat. Within the boat itself, ensure that the AC ground bus is connected to the DC ground bus at exactly one place (no more, no less). All pumps, metallic valves and fittings in the seawater circuit that are isolated from the air conditioning unit by PVC or rubber hoses must be individually bonded to the boat's bonding system also. This will help eliminate any possibility of corrosion due to stray current.

Note: Failure to properly ground and bond the system will void the warranty!

Electrical Connections, Grounding & Bonding for DC Powered Cuddy dc

All Cuddy dc units are connected by polarized plugs to the Dedicated Power Module DPM, pump, and control (available separately or in kit). These plugs are configured unique to each component. Wiring diagrams and schematics are provided in this manual (see Figure 10 at the back of this manual). A 60 amp circuit breaker or fuse should be installed at the positive side of the battery to protect the wires. Any electrical connections in the bilge below the waterline should be heat shrink type. **Turn off DC power supply circuit breaker before making connections.**

The air conditioning unit and its components must be connected to the boat's bonding system to prevent corrosion due to stray electrical current. There is a bonding ground stud on the Dedicated Power Module. This stud must be connected to the vessel's bonding

stud, which is typically on the engine block. This connection must be made per ABYC specifications. All pumps, metallic valves and fittings in the seawater circuit that are isolated from the air conditioning unit by PVC or rubber hoses must be individually bonded to the boat's bonding system also. This will help eliminate any possibility of corrosion due to stray current.

Note: Failure to properly ground and bond the system will void the warranty!

Electrical System and Wiring for DC Powered Cuddy dc

Dometic recommends a separate set of batteries dedicated for the Cuddy dc air conditioning system. Deep cycle AGM or Gel Cell batteries are the best for this application. If need be, please contact your Dometic dealer for assistance in sizing batteries.

The Cuddy dc kit contains the Dedicated Power Module (DPM). The DPM is meant to be used for the Cuddy dc system only and is sized to do so (see Figure 11 at the back of this manual for DPM specifications).

When connecting the DPM to the batteries, maintain correct wire size as shown in the DC Wire Sizing Table (see Figure 12 at the back of this manual), keep wire runs as short as possible, and with as few intermediate connections as possible, to avoid unnecessary resistance or voltage drop. See wiring diagram Figure 10 for location of customer-installed 60 amp fuse. Use an ignition protected fuse holder if installed in the engine compartment or in any area with flammable or compressed gasses or liquids (see the Safety Considerations section of this manual for more information). A standard ABYC approved battery disconnect switch is also recommended and should be used any time the system needs servicing. Do not forget to maintain proper color coding, (red = positive, black = negative) to aid in future electrical troubleshooting. If the wires are incorrectly connected (positive and negative reversed), the air conditioning unit will not start and the DPM will be damaged.

The DPM is wired to the FAN setting on the two-knob switch assembly and is energized only when the Cuddy dc is running (see the Operation section of this manual). For DC wire sizing, see Figure 12 at the back of this manual.

As batteries age, their peak voltage lowers and they discharge quicker. This, of course, can affect the air conditioner performance as well as other DC devices. The battery condition should be maintained and monitored regularly and weak batteries should be replaced. A battery isolator, combiner or selector switch will allow simultaneous charging while preventing the discharge of a fully charged battery into a depleted one.

Over current protection, in addition to fuse provided, must be supplied for the ungrounded conductor at the main switchboard, per ABYC E-9. Use a 60 amp breaker for 12 VDC systems. This provides protection from possible short circuits. When dockside, the Cuddy dc unit can operate against the batteries while using the AC battery charger (50 amp min) as a backup (most marine battery chargers will shut off when the battery is fully charged).

Ensure that all DC electrical connections are made in compliance with American Boat and Yacht Council (ABYC) standards section E-9.

Notice and ABYC Standards

Field wiring must comply with ABYC electrical standards. Power to the unit must be within the operating voltage range indicated on the data plate. Properly sized fuses and circuit breakers must be installed for branch circuit protection. See equipment rating plate for maximum size. All air conditioning units must be effectively grounded to minimize the hazard of electric shock and personal injury. The following standards apply:

1. AC (alternating current) grounding (green) wire must be provided with the AC power conductors and connected to the ground terminal (marked "GRND") at the AC power input terminal block of the unit(s), per ABYC standard E-8.
2. Connections between the vessel's AC system grounding conductor (green wire) and the vessel's DC (Direct Current) negative or bonding system should be made as part of the vessel's wiring, per ABYC standard E-9.
3. When servicing or replacing existing equipment containing a chassis-mounted "ground" stud, the service person or installer must check the vessel's wiring for the existence of the connection required in item 2 above.

ABYC standards are available from:

American Boat and Yacht Council
613 Third Street, Suite 10
Annapolis, MD 21403
Phone: (410) 990-4460
Fax: (410) 990-4466

Seawater Pump and Plumbing

Several guidelines should be followed during the installation of the seawater system. Since the circulation pump is centrifugal and not self-priming, it must be mounted so that it is always at least one foot below the water line regardless of which tack the vessel is on. Pump may be mounted horizontally or vertically, however the discharge must always be above the inlet. Pump head should be rotated toward the direction of water flow. **Install the seawater speed scoop intake as far below the water line and as close to the keel as possible in any application, but especially on a sailboat, to keep the intake in the water when the boat heels over so that air does not get into the system.** The speed scoop intake must face forward and not be shared with any other pump. A seawater strainer is mandatory between the shut off valve (seacock) and the pump to protect the pump from any foreign matter. **Failure to install a seawater strainer will void the pump warranty.** The seawater system should be installed with an upward incline from the speed scoop & seacock, through the strainer, to the inlet of the pump and then up to the inlet of the air conditioning unit's condenser coil. The discharge from the air conditioning unit should then run to the seawater outlet thru-hull fitting which should be located where it can be visually checked for water flow and as close as practicable to the waterline to reduce noise. All hose connections shall be secured by means of double/reversed stainless steel hose clamps. Use teflon tape on all threaded connections. The following is a summary of the seawater system installation:

1. Install the speed scoop thru-hull inlet as close to the keel and as far below the water line as possible, facing forward. Bed the scoop with a marine sealant designed for underwater use.
2. Install a bronze, full flow seacock on the speed scoop thru-hull inlet.
3. Install a seawater strainer below the level of the pump with access to filter.
4. Mount the pump above the strainer and at least one foot below the waterline.
5. Connect the seacock and strainer with an uphill run of 5/8" (16mm) reinforced marine grade hose.
6. Connect the discharge from the pump uphill to the bottom inlet of the air conditioning unit's condenser coil with 5/8" (16mm) reinforced marine grade hose. Connect the discharge from the condenser coil to the overboard discharge thru-hull fitting with 5/8" (16mm) reinforced marine grade hose.
7. Avoid loops, high spots or the use of 90° elbows with seawater hose (each 90° elbow is equivalent in pressure drop to 2.5' [76.2cm] of hose and a 90° elbow on the pump outlet is equivalent to 20' [609.6cm] of hose).

8. Double clamp all hose connections with stainless steel clamps, reversing the clamps.
9. Use teflon tape on all threaded connections.
10. ***Connect all metallic parts in contact with seawater to the vessel's bonding system including the speed scoop inlet, strainer, pump and the air conditioner.***

Refer to Figure 6 and the Cool Mate Kit drawings, Figures 14-17, at the back of this manual for seawater kit installation drawings.

Installation Checklist (review prior to and after installation)

Seawater cooling system

- Speed scoop located as far below the water line and as close to the keel as possible
- Shut off valve and speed scoop properly sealed and tight
- Seawater pump at least one foot below water line and securely mounted
- Strainer mounted below pump with access to filter
- Double/reversed stainless steel hose clamps on all hose connections
- Teflon tape on all threaded connections
- Hose runs uphill from speed scoop to strainer, pump and air conditioning unit
- Water flowing freely from overboard discharge while pump is running

Air Conditioner Unit Mounting

- Not in engine room or bilge areas, must be sealed away from exhaust or fumes
- Proper spacing allowed around unit
- Attached to solid level platform with four hold down clips provided
- Condensate drain line routed aft and down hill to a sealed sump (not bilge), and should have a trap

Grilles and Ducting

- Supply air grille mounted as high as possible
- Return air grille mounted as low and as close to the unit as possible
- Return air grille mounted away from exhaust and bilge vapors
- Ducting is pulled taut, straight and properly connected with no excess

Electrical for AC Powered Cool Mate

- All butt connections on pump wire tightly crimped and heat shrunk
- AC power source installed and grounded/bonded in accordance with ABYC standards
- Control wires connected to terminal strip with ring terminals

Electrical for DC Powered Cuddy dc

- All polarized plugs connected securely with an audible "snap"
- DC power source installed and grounded/bonded in accordance with ABYC standards
- Bonding ground stud on Dedicated Power Module connected to vessel's bonding system per ABYC

OPERATION

Operation

Manual Control Panel Operation:

1. Ensure seawater intake ball valve (seacock) is open.
2. Turn top (MODE) control knob to OFF. (See Figure 5)
3. Turn on air conditioning unit circuit breaker. If the seawater pump has its own circuit breaker, turn that on too.
4. Turn top (MODE) control knob to FAN, this energizes the fan (and the DPM in Cuddy dc systems).
5. Turn THERMOSTAT control knob to the coolest position by rotating it fully clockwise.
6. Verify that the fan is running and that there is steady airflow out of the supply air grille.
7. Turn top (MODE) control knob to RUN. This will start the compressor and seawater pump.
8. Check for a steady solid stream of seawater from the overboard discharge.
9. To set the THERMOSTAT, allow sufficient time for the unit to cool the area to the desired temperature. When the area is sufficiently cooled, turn the thermostat knob slowly toward the center position until it clicks once. The thermostat is now set to maintain a constant temperature.

Important

Do not turn the unit off and immediately turn it back on. Wait at least 30 seconds (2 minutes for the Cuddy dc) for system refrigerant pressures to balance.

Troubleshooting Guidelines

Before you call for service, review this list. It may save you time and expense. This list contains common occurrences that are not a result of defective workmanship or materials. If you need service after trying these procedures, call your nearest Marine Air dealer.

Problem: System will not start.

Possible Reason/Solution

1. **Air conditioner circuit breaker is off.** Turn circuit breaker on at ship's panel.
2. **Wiring at terminal strip is miswired (VAC unit only).** Check wiring diagram; correct if necessary.
3. **Input line voltage is insufficient (VAC unit only).** Check power source for proper voltage. Check wiring and terminals for proper sizes and connections.

4. **Cuddy dc plugs are not connected tightly (DC unit only).** Check polarized plugs from unit to pump, power module, and control. There should be an audible "snap" when plugs go together.
5. **Batteries are not fully charged (DC unit only).** Turn Cuddy dc unit off and charge battery bank.
6. **DC power wires are incorrectly sized (DC unit only).** See the "Electrical System and Wiring for DC Powered Cuddy dc" section of this manual. Ensure that DC power wires are sized and connected correctly.
7. **Dedicated Power Module (DPM) is in lockout mode (DC unit only).**

The DPM has a protective overload lockout feature that will cause it to shutdown in case of a problem. When this occurs, turn Cuddy dc off and wait 2 minutes before turning back on. If that does not solve the problem, then continue reading:

- a) If DPM has overheated ($\geq 167^{\circ}\text{F}$ [75°C]) then ensure that it has at least one inch of air space above unit for, and is in an area that provides, proper ventilation.
- b) If compressor has overheated then check water pump, strainer and hoses. When operating properly, there should be a steady stream of water from the overboard discharge. Strainer may need cleaning. Ensure that hoses are not kinked or restricted in some other way. Pump should come on with the compressor when control is set to RUN.
- c) If refrigerant pressure is too high, then turning the system off for 2 minutes should correct that by allowing pressure to equalize. Note: Turning the Cuddy dc on and off too quickly may cause a high-pressure shutdown. During normal operation wait at least 2 minutes from the time control is turned off until it is turned back on.
- d) If DC voltage is too high ($>16\text{-}17\text{VDC}$) or too low ($<10.5\text{VDC}$), then check battery bank for correct charge. Charge batteries if need be. Note: Turn Cuddy dc off and charge batteries for 5 minutes. Try turning Cuddy dc on again. If it runs, then that is a good indicator the batteries were low. Fully charge batteries at this time.

- e) If there is a dead short in the wiring, then disconnect power supply and repair wiring.

If, after trying all of the above, the fan runs, but the compress and pump do not, then that is a good indicator there is a problem with the compressor and/or pump. Whereas, if the fan does not come on at this time, then that is a good indicator there is a problem with the fan or the DPM. Either way, call for a service technician – please see listing in back of this manual.

Problem: No cooling.

Possible Reason/Solution

1. **Selector knob may not be in “cool” position.** Reset selector knob.
2. **Temperature set point is above ambient temperature.** Lower temperature setting.
3. **Obstructed water flow.** Clean seawater strainer. Check for good steady flow from overboard discharge.
4. **Pump may be air locked.** Remove hose from pump discharge to purge air from line.
5. **Coil iced.** See below.

Problem: Coil iced.

Possible Reason/Solution

1. **Thermostat set point is too low.** Check setting on temperature knob. If setting is extreme for conditions, raise set point.
2. **Improper air flow.** Clean return air filter or remove obstructions from return air stream. Check for crushed or restricted ducting. Ducting run must be as straight as possible; remove any excess ducting.

Problem: Short cycling compressor.

Possible Reason/Solution

1. **Cold supply air returning directly to return air grille.**
Redirect supply air so that it is not directed into the return air stream.

Problem: System runs continuously.

Possible Reason/Solution

1. **Port hole or hatch open.** Close all port holes and hatches.
2. **Thermostat setting is excessive for conditions.**
Raise thermostat setting to cycle compressor.

MAINTENANCE

Seawater Strainer

Ensure that the pump receives adequate seawater flow by regularly cleaning the strainer basket. Periodically check the overboard discharge for a steady stream of water. Check seawater intake speed scoop for obstructions. Make sure hoses are not looped, kinked or crushed.

Condenser Coil Cleaning

Coils can become fouled over a period of time due to marine growth or scale build-up. This both obstructs water flow and prohibits proper heat transfer. To clean coils, flush with a 5% muriatic or hydrochloric acid and fresh water solution. Disconnect system hoses from coil and pump the solution through until clean. Rinse with fresh water and reconnect hoses. Follow manufacturer's safety guidelines for all cleaning solutions.

Return Air Filters

Check the return air filter about once a month and clean as necessary. To clean the filter, remove it from the unit, rinse with water, air dry and reinstall.

Winterization

There are several methods of winterization, some of which work better than others. The four various methods employed using a 50/50 non-polluting biodegradable anti-freeze/water solution are:

1. Pumping of anti-freeze solution into the overboard thru-hull fitting, and discharging through the intake thru-hull fitting.
2. Use of the seawater pump to pump anti-freeze solution through the system and discharging through the overboard thru-hull fitting. Close seacock, remove hose from strainer discharge, raise hose above pump (so pump does not lose its prime) and pour in anti-freeze solution. Pump solution through system. The strainer and hose to seacock will also need to be drained of water.
3. Use of pressurized air injected at the overboard discharge fitting and the water being discharged through the seawater intake fitting.
4. Use of pressurized air to force water from the intake through the overboard discharge.

Note:

Collect all discharged liquids and recycle or dispose of in a proper manner.

Any method that causes the anti-freeze solution to flow downward is the method of choice. By this means, the anti-freeze solution will displace any water trapped and eliminate the possibility of freezing in hidden areas.

In addition, since the seawater pump utilizes a magnetically driven impeller, the impeller should be removed from the wet end assembly, wiped with an alcohol solution, and stored in a warm, dry area until commissioning takes place.

MANUFACTURERS LIMITED WARRANTY AGREEMENT

The following warranty is extended to cover the Marine Air Systems (MAS) **Cool Mate**® and **Cuddy dc** series of self contained air conditioners manufactured or supplied by Dometic Environmental Corporation (Dometic), and is subject to qualifications as indicated. Dometic warrants for the periods set forth below that products manufactured or supplied by it will be free from defects in workmanship and material, provided such products are installed, operated and maintained in accordance with Dometic's written instructions.

ALL IMPLIED WARRANTIES INCLUDING MERCHANTABILITY AND FITNESS FOR A PARTICULAR PURPOSE, ARE LIMITED TO THE TERMS AND PERIODS OF WARRANTY SET FORTH BELOW AND, TO THE EXTENT PERMITTED BY LAW, ANY AND ALL IMPLIED WARRANTIES ARE EXCLUDED.

Components comprising a complete system on a new installation are covered as follows:

Equipment bought through a catalog is covered by a limited one (1) year warranty from the date of purchase, but not to exceed two (2) years from date of manufacture. Labor costs are covered for six (6) months from the date of purchase. Travel costs are not covered.

Equipment installed by an OEM is covered by a limited one (1) year warranty from the date of purchase of the vessel, but not to exceed two (2) years from date of manufacture. Labor and travel costs are covered for one (1) year from the date of purchase of the vessel.

Equipment installed by a MAS authorized dealer is covered by a limited one (1) year warranty from the date of installation, but not to exceed two (2) years from date of manufacture. Labor costs are covered for six (6) months from the date of installation. Travel costs are not covered.

Warranty will be paid in accordance with our established

schedule of allowances. **Compensation for warranty repairs is only made to Dometic authorized service companies.**

Dometic will repair or replace at its option, components found to be defective due to faulty materials or workmanship, when such components, examined by an authorized service dealer or a factory service representative, are found to have a defect for which the company is responsible. In addition, Dometic will pay labor costs as outlined in its Schedule of Limited Warranty Allowances for removal and reinstallation of such components. Replacement components are warranted for the duration of the remaining warranty period in effect on the original component. In the event that a unit has to be returned to the factory, it must be properly packaged to prevent shipping damages. If packaging is not available, Dometic will provide it at no charge. The warranty may be voided on any piece of equipment or component that is damaged due to improper packaging.

This limited warranty is extended in lieu of all other warranties, agreements or obligations, expressed or implied, concerning Marine Air Systems' components. This limited warranty is extended only to the original purchaser and is not transferable. This warranty shall be governed by the laws of the State of Florida and gives the original first end user definite legal rights.

This warranty does not cover damages incidental and or consequential to the failure of Marine Air Systems' equipment including but not limited to; normal wear, accident, misuse, abuse, negligence, improper installation, lack of reasonable and necessary maintenance, alteration, civil disturbance or act of God.

No person or dealer is authorized to extend any other warranties or to assume any other liabilities on Dometic's behalf, unless made or assumed in writing by an officer of Dometic.

DESCRIPTION OF FIGURES

- Fig. 1 Spacing Allowances & Unit Dimensions for Mounting**
- Fig. 2 Component Identification**
- Fig. 3 Mounting Bracket Drawing**
- Fig. 4 Condensate Drain Drawing**
- Fig. 5 Typical Two-Knob Switch Assembly**
- Fig. 6 Seawater Pump and Plumbing Drawings**
- Fig. 7 Wiring Diagram of CLM3.5KC-HV**
- Fig. 8 Wiring Diagram of CLM5-16KC(Z)**
- Fig. 9 Wiring Diagram of CLM5KC(Z)-HV/EBM**
- Fig. 10 Cuddy dc CD3.5HV 12VDC Wiring Diagram**
- Fig. 11 Dedicated Power Module (DPM) Specs Tables**
- Fig. 12 DC Wire Sizing Table**
- Fig. 13 Cool Mate 3.5K and Cuddy dc Parts List**
- Fig. 14 Cool Mate 5K Kits Installation Diagram and Parts List**
- Fig. 15 Cool Mate 10K Kits Installation Diagram and Parts List**
- Fig. 16 Cool Mate 12K Kits Installation Diagram and Parts List**
- Fig. 17 Cool Mate 16K Kits Installation Diagram and Parts List**

Fig. 1 Spacing Allowances & Unit Dimensions for Mounting

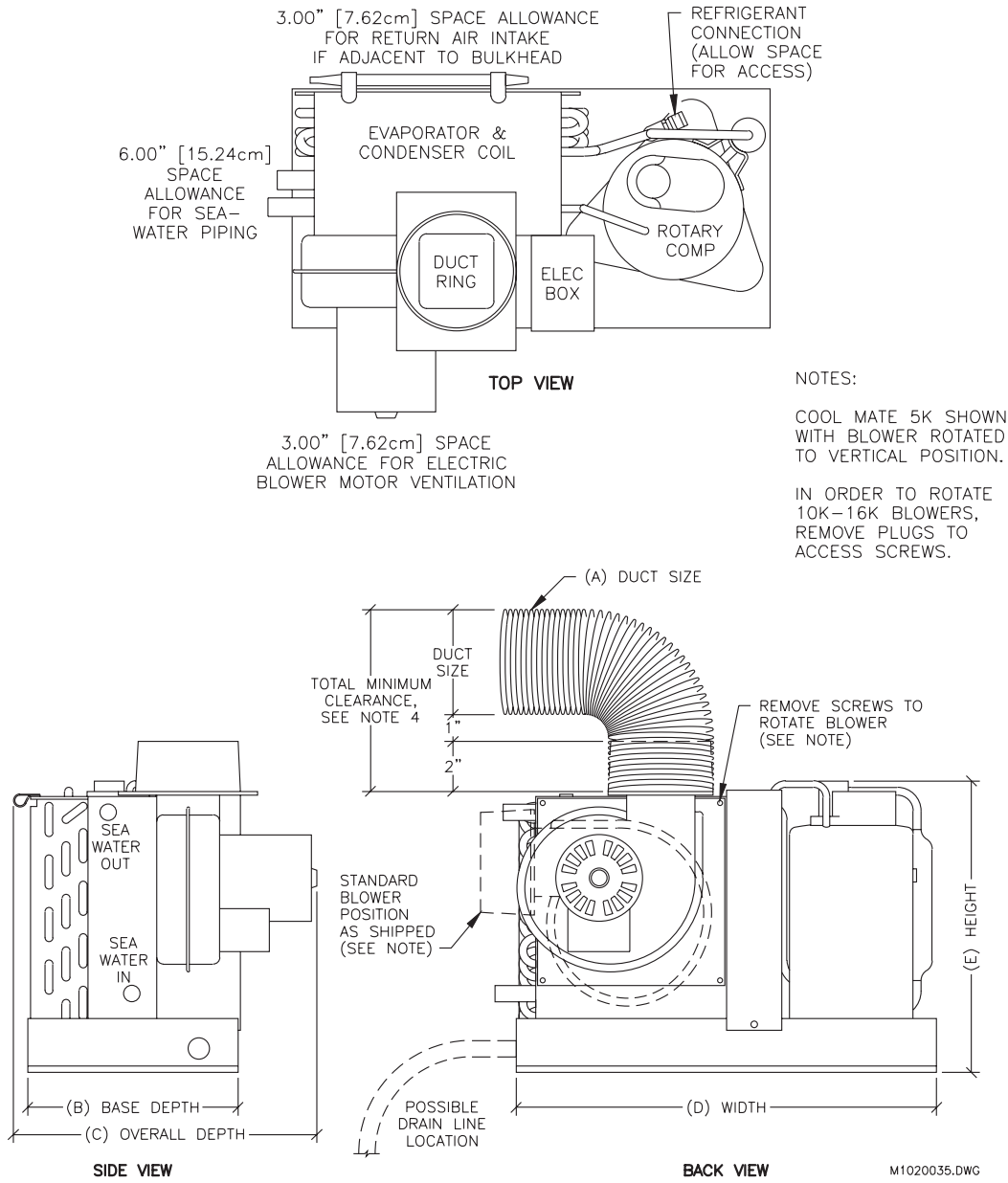

DIMENSIONS

Unit Capacity	3,500 BTU (in/mm)	5,000 BTU (in/mm)	10,000 BTU (in/mm)	12,000 BTU (in/mm)	16,000 BTU (in/mm)
A – Duct Size	3.0/76	4.0/102	6.0/152	6.0/152	6.0/152
B – Base Depth	8.0/203	8.0/203	8.4/213	8.4/213	9.0/229
C – Overall Depth	9.0/229	11.6/294*	12.2/310	12.2/310	12.8/325
D – Width	15.0/381	16.0/407	19.0/483	19.0/483	20.0/508
E – Height	9.3/235	11.6/294	12.9/328	13.3/337	13.3/337

* Overall depth of 5K High Velocity unit is 9.0"/229mm.

Fig. 2 Component Identification

15) NOTE:
AIR CONDITIONER SHOWN
WITH BLOWER ROTATED
TO VERTICAL POSITION.

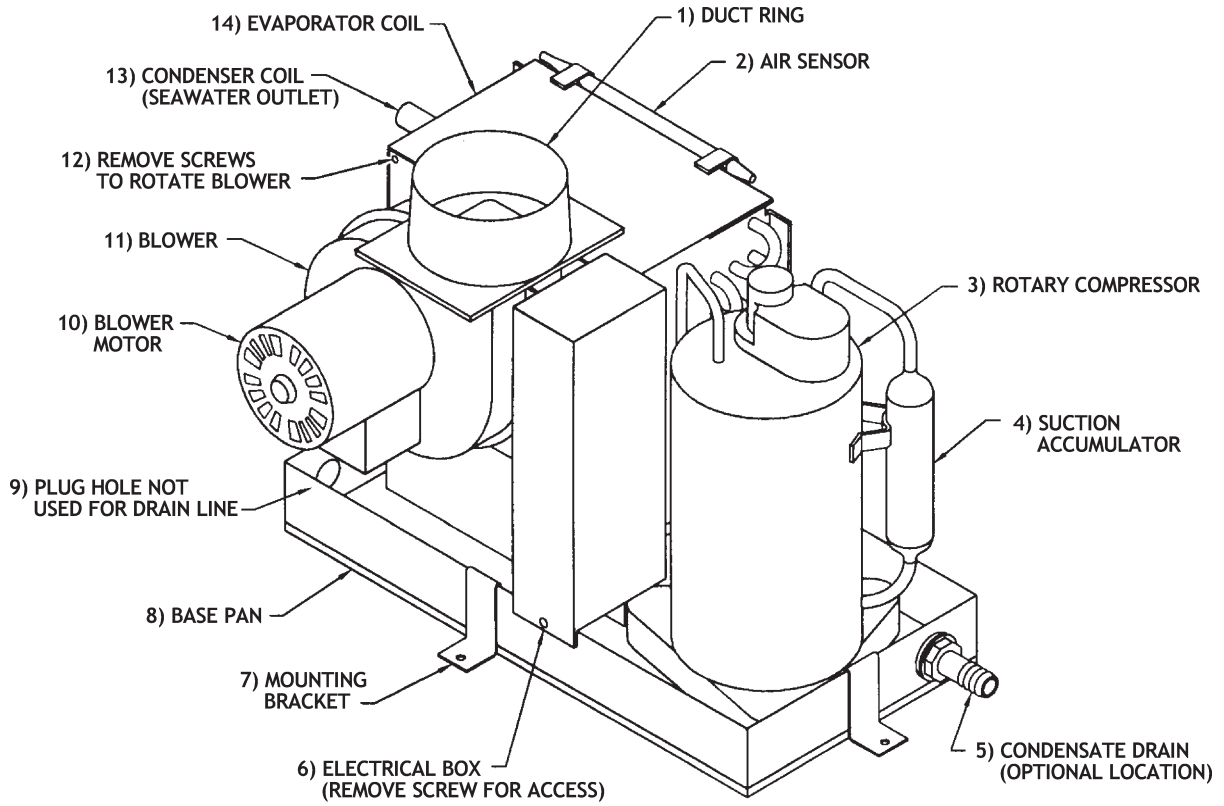

Fig. 3 Mounting Bracket

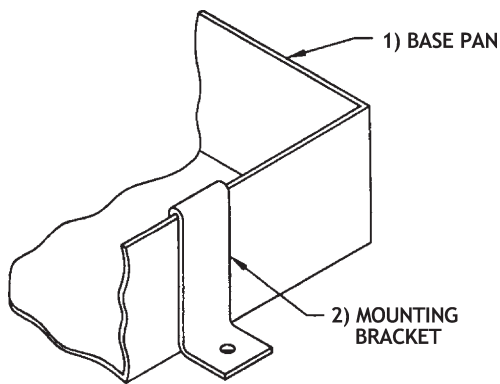

Fig. 4 Condensate Drain

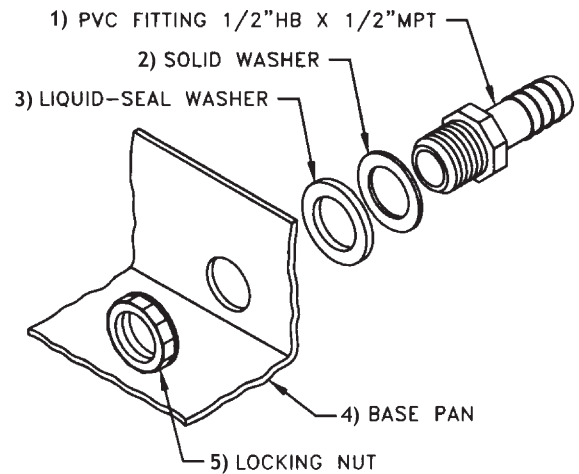

Fig. 5 Typical Two-Knob Switch Assembly

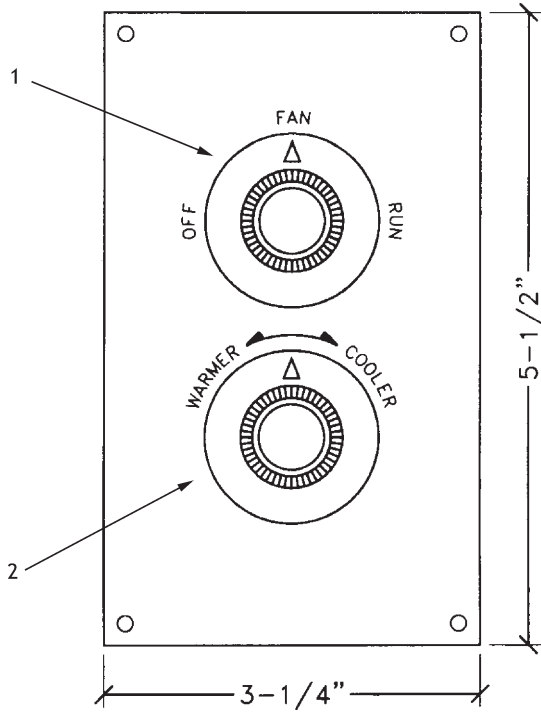
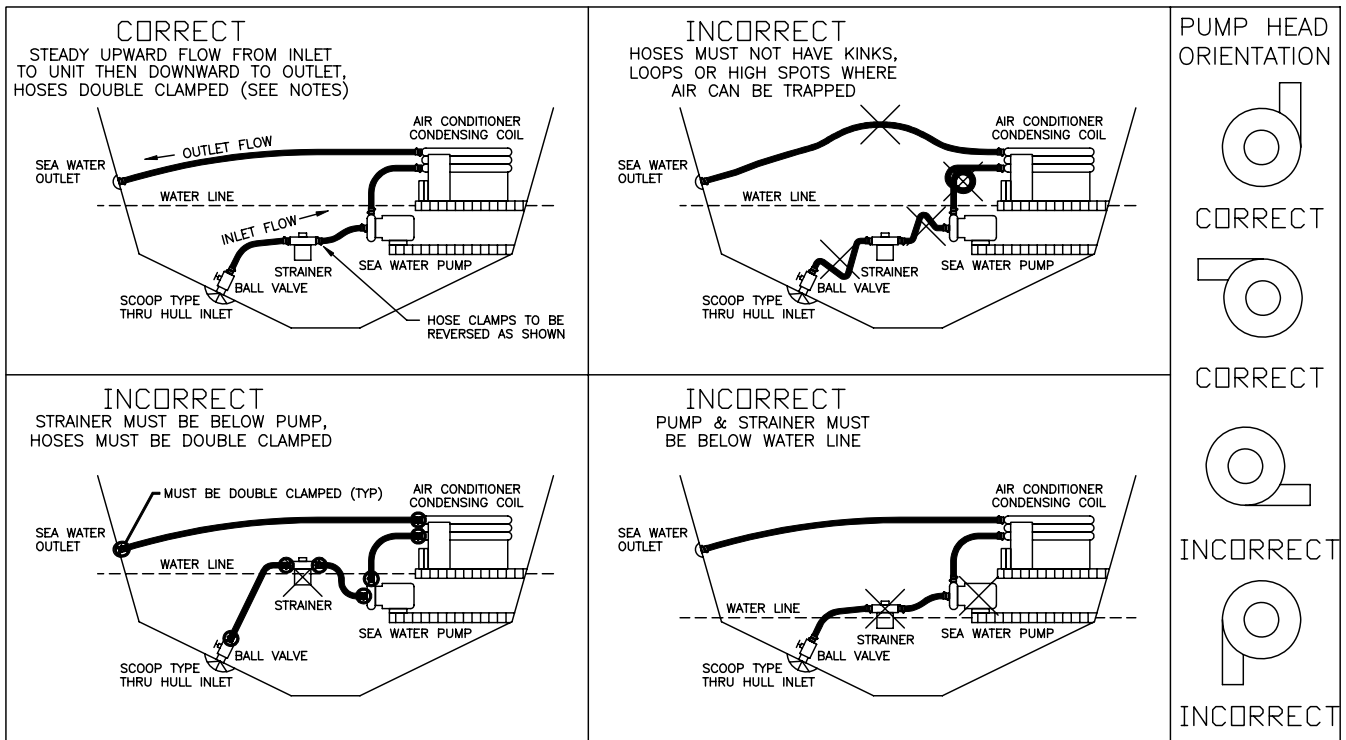

Fig. 6 Seawater Pump & Plumbing Diagrams



- NOTES:
- 1) THRU HULL INLET, BALL VALVE, HOSE AND STRAINER SHOULD BE SIZED NO SMALLER THAN PUMP INLET.
 - 2) INSTALL THRU HULL FITTING AS FAR BELOW THE WATER LINE AS POSSIBLE.
 - 3) PUMP NEEDS DEDICATED THRU HULL NOT SHARED WITH OTHER PUMPS.
 - 4) AVOID OR MINIMIZE 90° ELBOW FITTINGS AS MUCH AS POSSIBLE, ROTATE PUMP HEAD TOWARDS DIRECTION OF WATER FLOW.

Fig. 7 Wiring Diagram of CLM3.5KC-HV

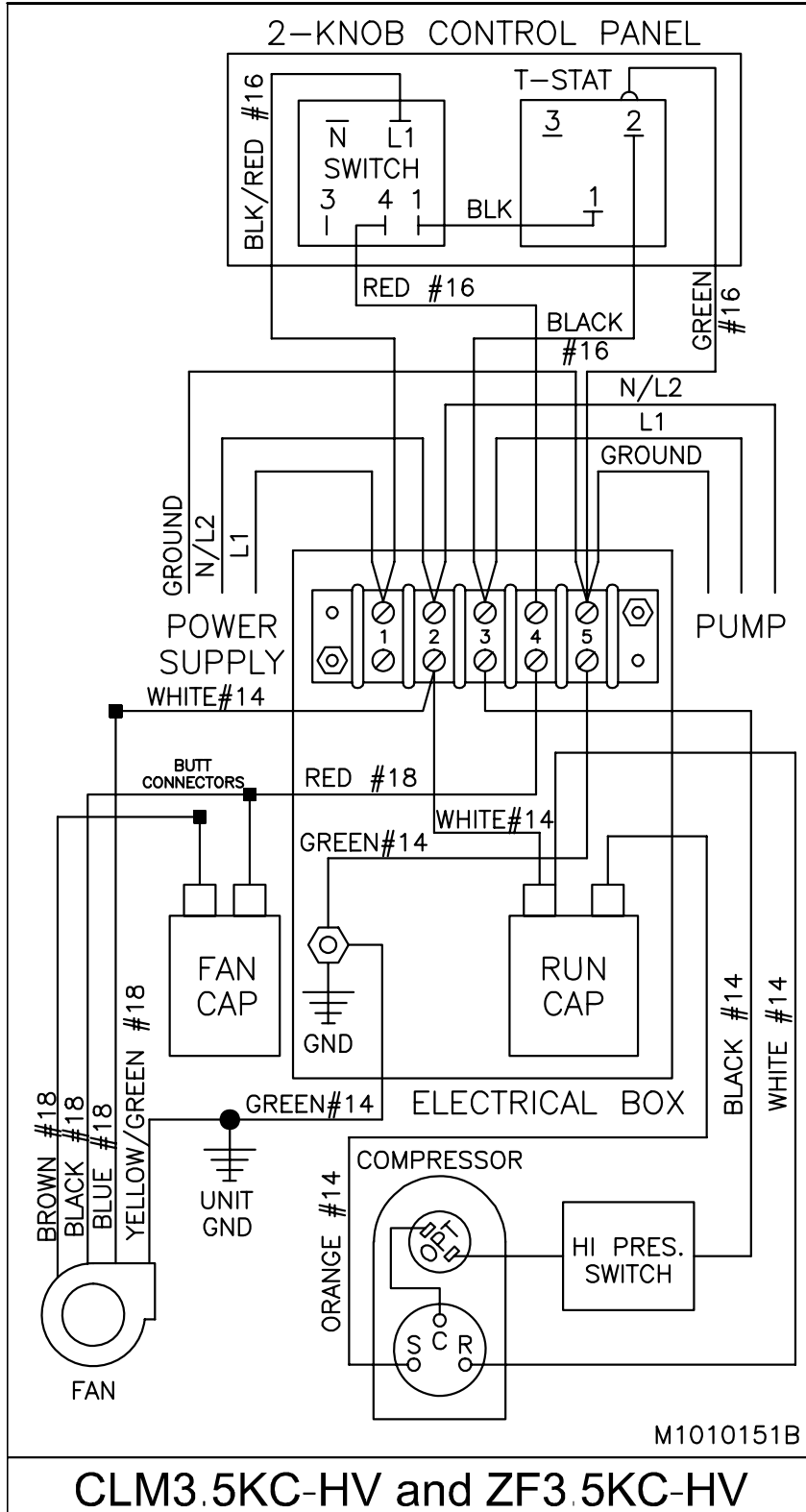
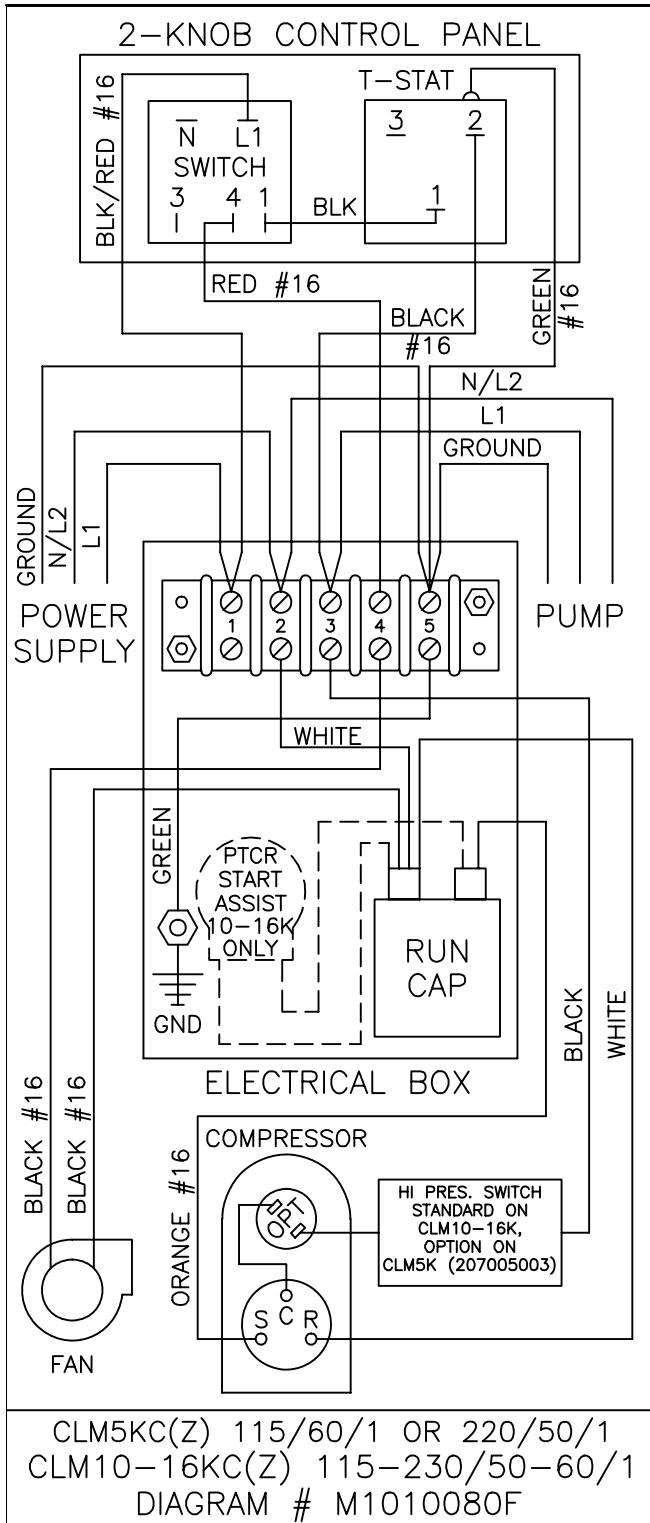
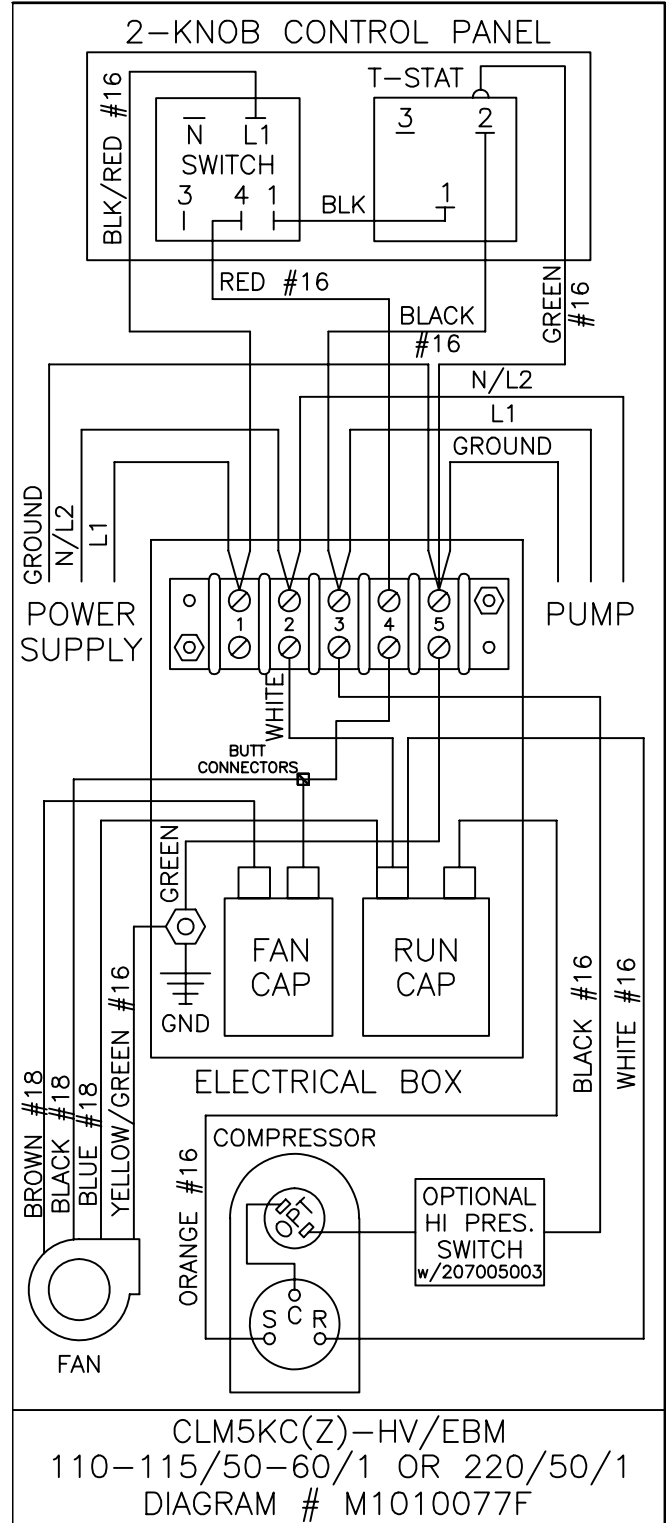

Fig. 8 Wiring Diagram of CLM5-16KC(Z)



ALL WIRES 12 GA
 UNLESS OTHERWISE NOTED

Fig. 9 Wiring Diagram of CLM5KC(Z)-HV/EBM



ALL WIRES 12 GA
 UNLESS OTHERWISE NOTED

Fig. 10 Cuddy dc CD3.5HV 12VDC Wiring Diagram

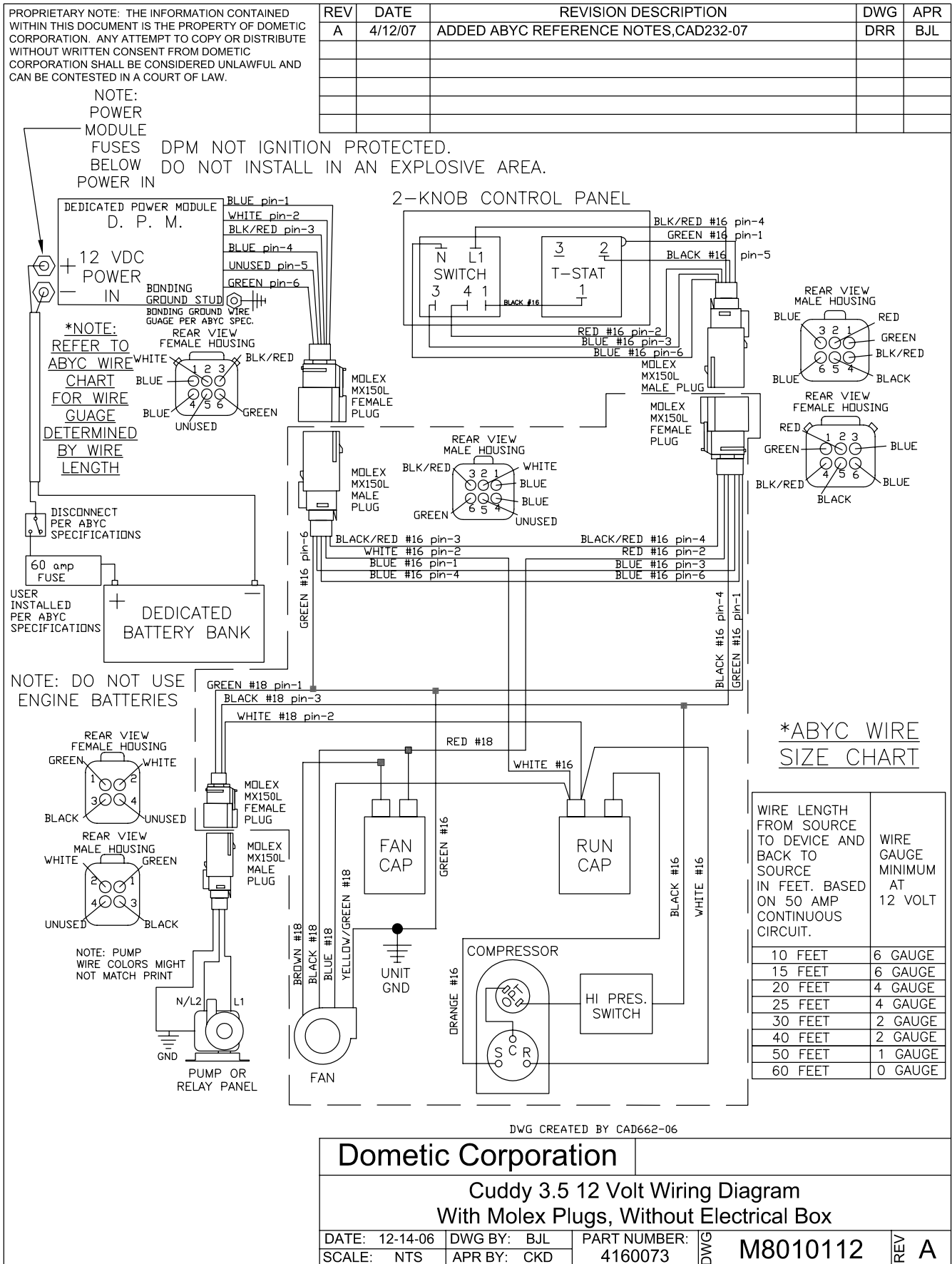

Fig. 11 Dedicated Power Module (DPM) Specs Tables for Use With Cuddy dc Systems Only

Electrical Specifications

Output Waveform	Modified Sine-Wave
Output Power	600W Continuous
Output Surge Rating	1200W for 1 sec
Output Voltage	115VAC ± 10%
Output Frequency	60Hz (±4Hz)
Input DC Voltage Range	11 - 15VDC
Input Low Voltage Shutdown	< 10.5VDC ± 0.2VDC
High Temperature Shutdown	Thermistor ≥167°F (75°C)
Reverse Polarity Protection	External Fuse
No Load Current Draw	0.75A~0.95A
Efficiency	~90%
Over-voltage Shut-down	16-17VDC, restart below 16VDC

General Specifications

Isolation Voltage	Non-isolated
Operating Temperature Range	-13 ~ 122°F (-25 ~ +50°C)
Storage Temperature Range	-40 ~ 167°F (-40 ~ +75°C)
External Fuse	30A x 2
Safety	CE
Dimensions (L x W x H)	9.5 x 5.1 x 2.7" (241 x 130 x 69mm)
DC Input Connections (IN)	Ring Terminals
Net Weight	~2.9 lbs (1.3kg)
AC Output Connections	Per Dometic Wiring Diagram M8010112 in this manual
Ventilation	Allow at least 1" (25mm) above unit for adequate airflow.

LED Lights Scheme for DPM (see note)

Battery Energy Level	No Load	With Load
Full (Battery Voltage>13V)	Green	Green
Intermediate(12-13V)	Green	Orange
Low(<12V)	Red	Red

Note: LED lights may or may not be readily visible, depending on DPM installation location. This table is included as a convenience, but is not necessary for troubleshooting the system.

Fig. 12 DC Wire Sizing Table

DC Wire Size Table*		
Distance from battery (power source) to Cuddy dc unit	Total length of both positive and negative wires added together	Wire Size AWG
5 ft and under (1.5m and under)	10 ft and under (3.0m and under)	#6
5 ft to 7.5 ft (1.5m to 2.3m)	10 ft to 15 ft (3.0m to 4.6m)	#6
7.5 ft to 10 ft (2.3m to 3.0m)	15 ft to 20 ft (4.6m to 6.1m)	#4
10 ft to 12.5 ft (3.0m to 3.8m)	20 ft to 25 ft (6.1m to 7.6m)	#4
12.5 ft to 15 ft (3.8m to 4.6m)	25 ft to 30 ft (7.6m to 9.1m)	#2
15 ft to 20 ft (4.6m to 6.1m)	30 ft to 40 ft (9.1m to 12.2m)	#2
20 ft to 25 ft (6.1m to 7.6m)	40 ft to 50 ft (12.2m to 15.2m)	#1
25 ft to 30 ft (7.6m to 9.1m)	50 ft to 60 ft (15.2m to 18.3m)	#0

* Table derived from ABYC section E9, table 9 for 12 VDC systems. These specifications were calculated using 3% voltage drop and a maximum current draw of 50 amps for Cuddy dc air conditioner and pump.

Fig. 13 Cool Mate 3.5K and Cuddy dc Parts List

Cool Mate 3.5 Kit

CLM3.5KC-HV 115V

Condensate hose barb assembly with 4 mounting brackets included with unit.

P/N	Qty	Description
222-110081	1	MCP 2-Knob Control dual voltage
225-500226	1	Pump PML250 115V no fittings

Cuddy dc Kits

CD3.5HV 12VDC

Condensate hose barb assembly with 4 mounting brackets included with unit.

P/N	Qty	Description
222-110094	1	DPM Dedicated Power Module 12V with MX-Plug
222-110100	1	MCP 2-KB CDM V BL MYL 12V 150L 2-Knob Control
225-410108	1	Pump PML150 with MX150L-Plug 115V no fittings
-OR-	-	OR- (kit has one pump, PML150 or PML250)
225-410112	1	Pump PML250 with MX150L-Plug 115V no fittings

Extension Cables with Plugs for Cuddy dc Systems

222-120200	1	3m (9.8') Cable with Plugs from Cuddy dc to DPM
222-120201	1	6m (19.7') Cable with Plugs from Cuddy dc to DPM
222-120202	1	3m (9.8') Cable with Plugs for Cuddy dc to Pump

Air Distribution Kits

Kits (sold separately) are for use with Cool Mate or Cuddy dc 3.5K units only:

226-000301	Kit	Air Distribution Kit - Black (includes next 3 items)
333437	1	3" Round Plastic Supply Air Grill, Euro, Black
217-000773	1	8x8TRAF Alum Return Air Grill w/Filter, Black
226-600045	10'	3" Ducting, Insulated Flexible
226-000300	Kit	Air Distribution Kit - White (includes next 3 items)
333439	1	3" Round Plastic Supply Air Grill, Euro, White
217-000728	1	8x8TRAF Alum Return Air Grill w/Filter, White
226-600045	10'	3" Ducting, Insulated Flexible

Fig. 14 Cool Mate 5K Kits Installation and Parts List

MARINE AIR SYSTEMS COOL MATE 5K KITS

CLM5KC/1 115V KIT P/N 207-315005 OR CLM5KCZ50/1 220V/50Ø KIT P/N 207-315007 INCLUDES:
 COOL MATE 5K, 2-KNOB CONTROL, AND SEAWATER & DUCT KIT
 SEAWATER & DUCT KIT PART NUMBERS: 115V = 225-600017, 220V = 225-600018

DUCT KIT INSTALLATION

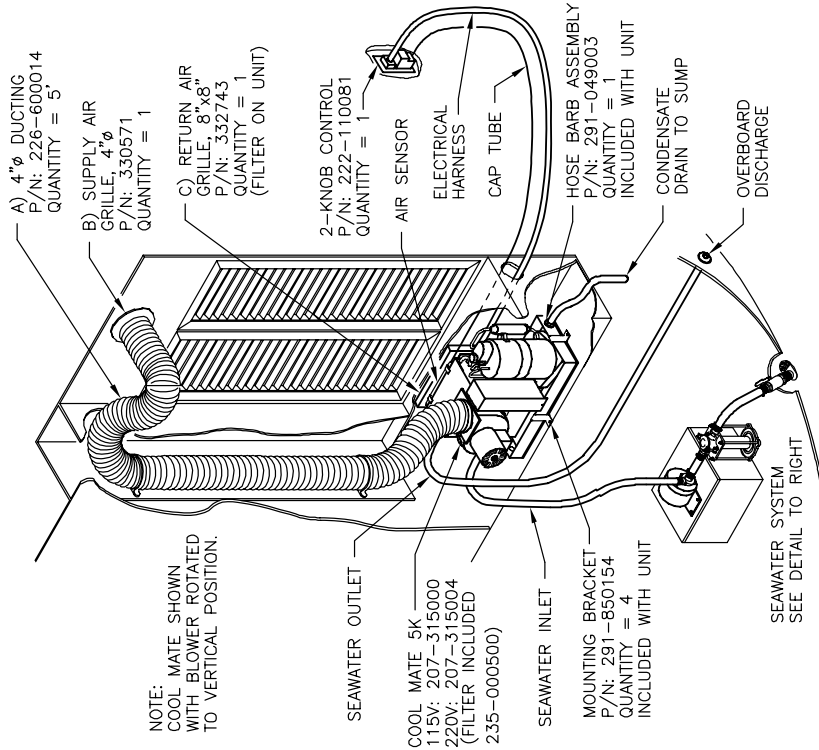

DUCT KIT:
 LEGEND QTY DESCRIPTION
 A 5' 226-600014 DUCTING, INSULATED 4"
 B 1 330571 GRILLE, CIRCULAR OFF WHT
 C 1 332743 GRILLE, 8X8"-RA ANODIZED

INSTALLATION NOTES:
 1) DO NOT INSTALL AIR CONDITIONER IN BILGE OR ENGINE ROOM AREAS. DO NOT TERMINATE CONDENSATE DRAIN LINE IN BILGE OR ANY AREA THAT MAY BE EXPOSED TO ENGINE OR GENERATOR EXHAUST FUMES. A/C UNIT MUST BE SEALED FROM ANY EXHAUST OR BILGE VAPORS.
 2) INSTALL RETURN AIR GRILLE LOW AND SUPPLY AIR GRILLE HIGH.
 3) SUPPLY AIR GRILLE SHOULD NOT BLOW TOWARD RETURN AIR GRILLE.
 4) DUCTING SHOULD BE INSTALLED AS SMOOTH AND TAUT AS POSSIBLE. TRIM ANY EXCESS, AVOID ANY UNNECESSARY BENDS OR LOOPS.

SEAWATER KIT INSTALLATION

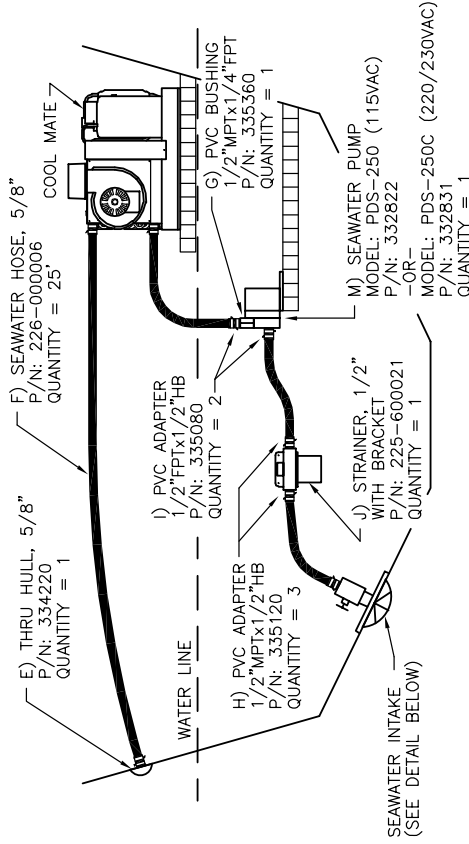

N) HOSE CLAMPS:
 ALL HOSE CONNECTIONS IN SEAWATER SYSTEM TO BE DOUBLE CLAMPED, HOSE CLAMPS TO BE REVERSED AS SHOWN
 P/N: 369617
 QUANTITY = 17

H) PVC ADAPTER 1/2" FPT x 1/2" HB
 P/N: 335120
 QUANTITY = 3

O) BALL VALVE, 1/2"
 P/N: 330482
 QUANTITY = 1

BACKING PLATE (NOT INCLUDED)

BEDDING COMPOUND (APPLY LIBERALLY TO BOTH SIDES AND THROUGHOUT HOLE, NOT INCLUDED IN KIT.)

P) SPEED SCOOP, 1/2"
 P/N: 369699
 QUANTITY = 1
 (FACING FORWARD)

SEAWATER KIT:
 LEGEND QTY

P/N	DESCRIPTION
334220	THRU HULL, 5/8" PLASTIC HOSE SEAWATER 5/8"
E 1	226-000006
F 25	BUSH, PVC RED 1/2" FPT x 1/4" FPT
G 1	335360
H 3	ADAPT, PVC 1/2" FPT x 1/2" HB
I 2	335080
J 1	ADAPT, PVC 1/2" FPT x 1/2" HB
K 1	225-600021
L 1	STRAINER W/BRACKET 1/2" FPT
M 1	N/A
N 17	332822
O 1	332831
P 3	369617
Q 1	330482
R 6	369699
	338439
	336750

- NOTES:
 1) SEAWATER SYSTEM MUST HAVE A STEADY UPWARD FLOW FROM INLET TO AIR CONDITIONER.
 2) HOSES MUST NOT HAVE KINKS, LOOPS OR HIGH SPOTS WHERE AIR CAN BE TRAPPED.
 3) PUMP AND STRAINER MUST BE BELOW WATER LINE AND STRAINER MUST BE BELOW PUMP.
 4) SPEED SCOOP SHOULD BE INSTALLED AS FAR BELOW THE WATER LINE AND AS CLOSE TO THE KEEL AS POSSIBLE, FACING FORWARD.
 5) AVOID OR MINIMIZE 90° BENDS OR ELBOWS AS MUCH AS POSSIBLE, ROTATE PUMP HEAD TOWARD DIRECTION OF WATER FLOW.
 6) ELECTRICAL CONNECTIONS USING ITEMS Q & R ARE TO BE DONE BY QUALIFIED PERSONNEL ONLY.

CLM5K DWG # M1030023G 10/13/03

Fig. 15 Cool Mate 10K Kits Installation and Parts List

MARINE AIR SYSTEMS COOL MATE 10K KITS

CLM10KC/1 115V KIT P/N 207-315024 OR CLM10KCZ/1 230V KIT P/N 207-315025 INCLUDES:
 COOL MATE 10K, 2-KNOB CONTROL, AND SEAWATER & SINGLE DUCT KIT IS OPTIONAL P/N 226-600084
 SEAWATER & DUCT KIT PART NUMBERS: 115V = 225-600022, 220-230V = 225-600023

DUCT KIT(S) INSTALLATION

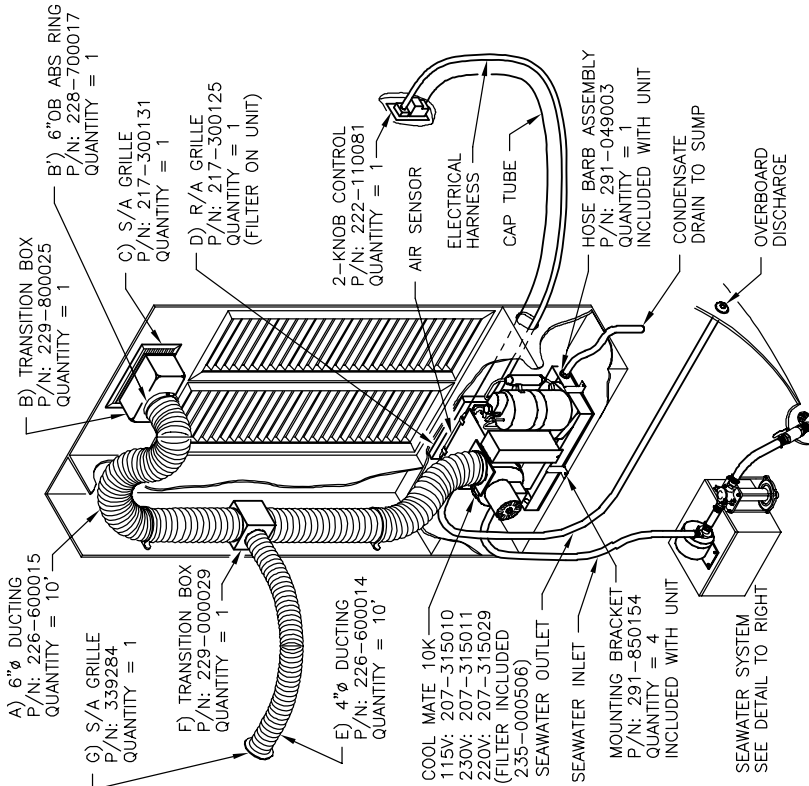

- SINGLE DUCT KIT:**
- | LEGEND | QTY | P/N | DESCRIPTION |
|--------|-----|------------|---------------------------------------|
| A | 10 | 226-600015 | 6" DUCTING, INSULATED FLEXIBLE |
| B | 1 | 229-800025 | TRANSITION BOX ABS 12x6x4.5 |
| C | 1 | 229-800017 | 6" ABS OBLONG TRANSITION RING |
| D | 1 | 217-300131 | 12x6"V ALUM SUPPLY AIR GRILLE |
| E | 1 | 217-300125 | 12x12"RA ALUM RETURN AIR GRILLE |
| F | 1 | 229-000029 | DUAL DUCT KIT ADDER (P/N 226-600084): |
| G | 1 | 339284 | 4" DUCTING, INSULATED FLEXIBLE |
| | | | TRANSITION BOX AE/B6.D6.E4-Z X33 |
| | | | 4SA GRILLE, 4" ROUND WHITE CLOSABLE |
- INSTALLATION NOTES:**
- DO NOT INSTALL AIR CONDITIONER IN BILGE OR ENGINE ROOM AREAS. DO NOT TERMINATE CONDENSATE DRAIN LINE IN BILGE OR ANY AREA THAT MAY BE EXPOSED TO ENGINE OR GENERATOR EXHAUST FUMES. A/C UNIT MUST BE SEALED FROM ANY EXHAUST OR BILGE VAPORS.
 - INSTALL RETURN AIR GRILLE LOW AND SUPPLY AIR GRILLE HIGH.
 - SUPPLY AIR GRILLE SHOULD NOT BLOW TOWARD RETURN AIR GRILLE. DUCTING SHOULD BE INSTALLED AS SMOOTH AND TAUT AS POSSIBLE. TRIM ANY EXCESS, AVOID ANY UNNECESSARY BENDS OR LOOPS.

SEAWATER KIT INSTALLATION

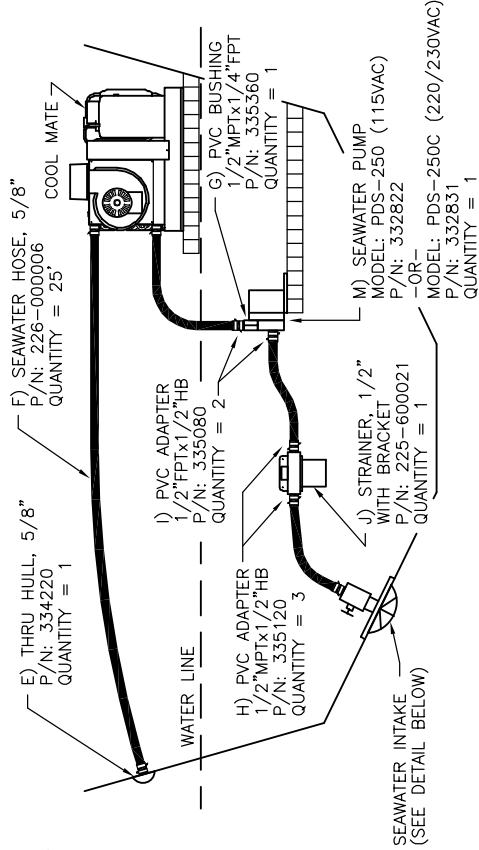

- N) HOSE CLAMPS:**
ALL HOSE CONNECTIONS IN SEAWATER SYSTEM TO BE DOUBLE CLAMPED, HOSE CLAMPS TO BE REVERSED AS SHOWN
P/N: 369617
QUANTITY = 17
- H) PVC ADAPTER**
1/2" MPTx1/2" HB
P/N: 335120
QUANTITY = 3
- O) BALL VALVE, 1/2"**
P/N: 330482
QUANTITY = 1
- BACKING PLATE**
(NOT INCLUDED)
- P) SPEED SCOOP, 1/2"**
P/N: 369699
QUANTITY = 1
(FACING FORWARD)
- SEAWATER KIT:**
- | LEGEND | QTY | P/N | DESCRIPTION |
|--------|-----|------------|-----------------------------------|
| E | 1 | 334220 | THRU HULL 5/8" PLASTIC |
| F | 25 | 226-000006 | HOSE SEAWATER 5/8" |
| G | 1 | 335360 | BUSH, PVC RED 1/2" MPTx1/4" FPT |
| H | 3 | 335120 | ADAPT, PVC 1/2" MPTx1/2" HB |
| G | 1 | 335080 | ADAPT, PVC 1/2" FPTx1/2" HB |
| J | 1 | 225-600021 | STRAINER W/BRACKET 1/2" FPT |
| K | - | N/A | |
| L | - | N/A | |
| M | 1 | 332822 | PUMP, PDS-250 115V SEAWATER |
| N | 17 | 332831 | PUMP, PDS-250C 220/230V SEAWATER |
| O | 1 | 369617 | CLAMP, HOSE #06SS THIN |
| P | 1 | 330482 | BALL VALVE 1/2" SS HNDL (BRONZE) |
| Q | 1 | 369699 | STRAINER, SPEED SCOOP 1/2" BRONZE |
| R | 3 | 338439 | TERMINAL BUILT SPLICE 16-14 |
| R | 6 | 336750 | TERMINAL RING 10-12 YELLOW |
- NOTES:**
- SEAWATER SYSTEM MUST HAVE A STEADY UPWARD FLOW FROM INLET TO AIR CONDITIONER.
 - HOSES MUST NOT HAVE KINKS, LOOPS OR HIGH SPOTS WHERE AIR CAN BE TRAPPED.
 - PUMP AND STRAINER MUST BE BELOW WATER LINE. STRAINER MUST BE BELOW PUMP AND ABOVE INLET.
 - SPEED SCOOP INLET SHOULD BE INSTALLED AS FAR BELOW THE WATER LINE AND AS CLOSE TO THE KEEL AS POSSIBLE, FACING FORWARD.
 - AVOID OR MINIMIZE 90° BENDS OR ELBOWS AS MUCH AS POSSIBLE; ROTATE PUMP HEAD TOWARD DIRECTION OF WATER FLOW.
 - ELECTRICAL CONNECTIONS USING ITEMS Q & R ARE TO BE DONE BY QUALIFIED PERSONNEL ONLY.

CLM10K DWG # M1030078B 10/13/03

Fig. 16 Cool Mate 12K Kits Installation and Parts List

MARINE AIR SYSTEMS COOL MATE 12K KITS

CLM12KC/1 115V KIT P/N 207-315014 OR CLM12KCZ/1 230V KIT P/N 207-315015 INCLUDES:
 COOL MATE 12K, 2-KNOB CONTROL, AND SEAWATER & SINGLE DUCT KIT IS OPTIONAL P/N 226-600084)
 SEAWATER & DUCT KIT PART NUMBERS: 115V = 225-600022, 220-230V = 225-600023

DUCT KIT(S) INSTALLATION

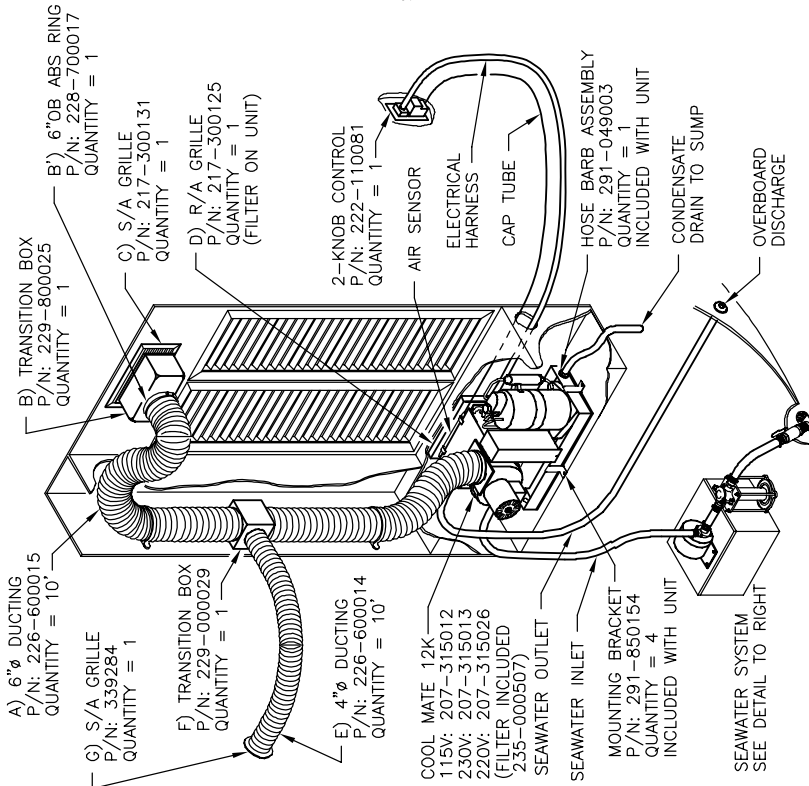

- SINGLE DUCT KIT:**
- | LEGEND | QTY | P/N | DESCRIPTION |
|--------|-----|------------|-------------------------------------|
| A | 10 | 226-600015 | 6" DUCTING, INSULATED FLEXIBLE |
| B | 1 | 229-800025 | TRANSITION BOX ABS 12x6x4.5 |
| C | 1 | 228-700017 | 6" ABS OBLONG TRANSITION RING |
| D | 1 | 217-300151 | 12x6TV ALUM SUPPLY AIR GRILLE |
| E | 1 | 217-300125 | 12x12TRA ALUM RETURN AIR GRILLE |
| F | 10 | 226-600014 | 4" DUCTING, INSULATED FLEXIBLE |
| G | 1 | 229-000029 | TRANSITION BOX AE/B6.D6.E4-Z X33 |
| H | 1 | 339284 | 4SA GRILLE, 4" ROUND WHITE CLOSABLE |
- INSTALLATION NOTES:**
- DO NOT INSTALL AIR CONDITIONER IN BILGE OR ENGINE ROOM AREAS. THAT MAY BE EXPOSED TO ENGINE OR GENERATOR EXHAUST FUMES. A/C UNIT MUST BE SEALED FROM ANY EXHAUST OR BILGE VAPORS.
 - INSTALL RETURN AIR GRILLE LOW AND SUPPLY AIR GRILLE HIGH.
 - SUPPLY AIR GRILLE SHOULD NOT BLOW TOWARD RETURN AIR GRILLE. DUCTING SHOULD BE INSTALLED AS SMOOTH AND TAUT AS POSSIBLE. TRIM ANY EXCESS, AVOID ANY UNNECESSARY BENDS OR LOOPS.

SEAWATER KIT INSTALLATION

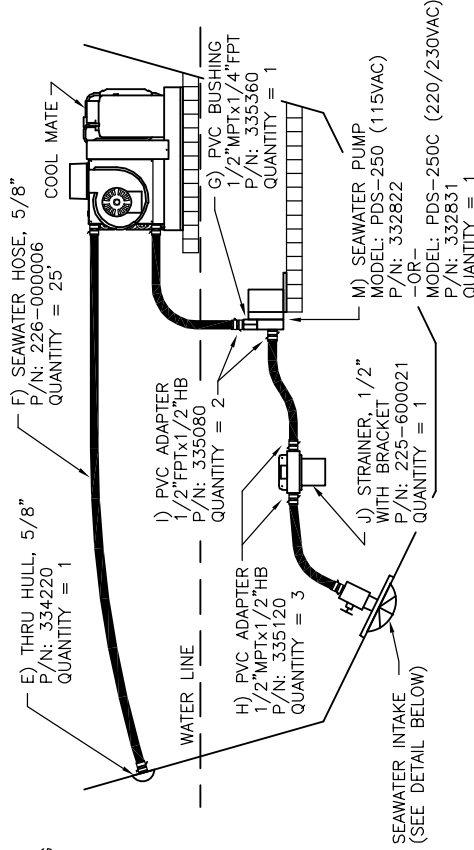

- SEAWATER KIT:**
- | LEGEND | QTY | P/N | DESCRIPTION |
|--------|-----|------------|-----------------------------------|
| E | 1 | 334220 | THRU HULL, 5/8" PLASTIC |
| F | 25' | 226-000006 | HOSE SEAWATER 5/8" |
| G | 1 | 335360 | BUSH, PVC RED 1/2" MPTx1/4" FPT |
| H | 3 | 335120 | ADAPT, PVC 1/2" MPTx1/2" HB |
| I | 2 | 335080 | ADAPT, PVC 1/2" FPTx1/2" HB |
| J | 1 | 225-600021 | STRAINER W/BACKET 1/2" FPT |
| K | 1 | N/A | N/A |
| L | 1 | 332822 | PUMP, PDS-250 115V SEAWATER |
| M | 17 | 332851 | PUMP, PDS-250C 220/230V SEAWATER |
| N | 1 | 369617 | CLAMP, HOSE #06SS THIN |
| O | 1 | 330482 | BALL VALVE 1/2" SS HNDL (BRONZE) |
| P | 1 | 369699 | STRAINER, SPEED SCOOP 1/2" BRONZE |
| Q | 3 | 338439 | TERMINAL, BUIT SPLICE 16-14 |
| R | 6 | 336750 | TERMINAL RING 10-12 YELLOW |
- NOTES:**
- SEAWATER SYSTEM MUST HAVE A STEADY UPWARD FLOW FROM INLET TO AIR CONDITIONER.
 - HOSES MUST NOT HAVE KINKS, LOOPS OR HIGH SPOTS WHERE AIR CAN BE TRAPPED.
 - PUMP AND STRAINER MUST BE BELOW WATER LINE. STRAINER MUST BE BELOW PUMP AND ABOVE INLET.
 - SPEED SCOOP INLET SHOULD BE INSTALLED AS FAR BELOW THE WATER LINE AND AS CLOSE TO THE KEEL AS POSSIBLE, FACING FORWARD.
 - AVOID OR MINIMIZE 90° BENDS OR ELBOWS AS MUCH AS POSSIBLE; ROTATE PUMP HEAD TOWARD DIRECTION OF WATER FLOW.
 - ELECTRICAL CONNECTIONS USING ITEMS Q & R ARE TO BE DONE BY QUALIFIED PERSONNEL ONLY.

- N) HOSE CLAMPS:**
 ALL HOSE CONNECTIONS IN SEAWATER SYSTEM TO BE DOUBLE CLAMPED, HOSE CLAMPS TO BE REVERSED AS SHOWN
 QUANTITY = 17
- H) PVC ADAPTER 1/2" MPTx1/2" HB**
 P/N: 335120
 QUANTITY = 3
- O) BALL VALVE, 1/2"**
 P/N: 330482
 QUANTITY = 1
- BACKING PLATE (NOT INCLUDED)**
- BEDDING COMPOUND (APPLY LIBERALLY TO BOTH SIDES AND THROUGHOUT HOLE, NOT INCLUDED IN KIT.)**
- HULL**
- P) SPEED SCOOP, 1/2"**
 P/N: 369699
 QUANTITY = 1
 (FACING FORWARD)

CLM12K DWG # M1030046E 10/13/03

Fig. 17 Cool Mate 16K Kits Installation and Parts List

MARINE AIR SYSTEMS COOL MATE 16K KITS

CLM16KC/1 115V KIT P/N 207-315018, CLM16KCZ/1 230V KIT P/N 207-315019, OR CLM16KCZ50/1 220V KIT P/N 207-315028 INCLUDES:
 COOL MATE 16K, 2-KNOB CONTROL, AND SEAWATER & SINGLE DUCT KIT (DUAL DUCT KIT IS OPTIONAL P/N 226-600085)
 SEAWATER & DUCT KIT PART NUMBERS: 115V = 225-600024, 220-230V = 225-600025

DUCT KIT(S) INSTALLATION

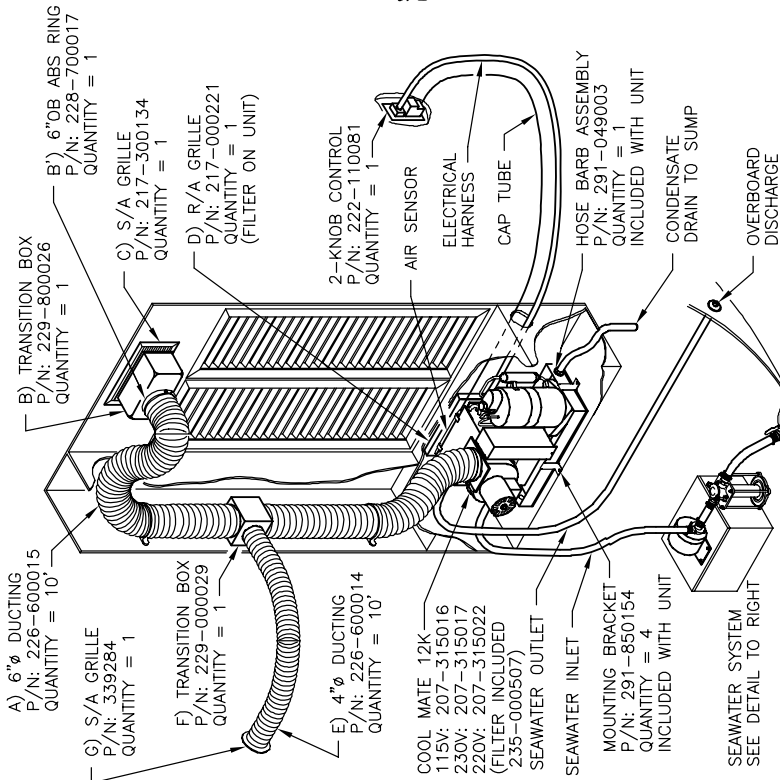

- SINGLE DUCT KIT:**
- | LEGEND | QTY | P/N | DESCRIPTION |
|--------|-----|------------|-------------------------------------|
| A | 10' | 226-600015 | 6" DUCTING, INSULATED FLEXIBLE |
| B | 1 | 229-800026 | TRANSITION BOX ABS 14x6x4.5 |
| B' | 1 | 228-700017 | 6" ABS OBLONG TRANSITION RING |
| C | 1 | 217-300134 | 14x6TV ALUM SUPPLY AIR GRILLE |
| D | 1 | 217-000221 | 14x12TRA ALUM RETURN AIR GRILLE |
| DUAL | 1 | 226-600085 | DUCT KIT ADDER (P/N 226-600085): |
| E | 10' | 226-600014 | 4" DUCTING, INSULATED FLEXIBLE |
| F | 1 | 229-000029 | TRANSITION BOX AE/B6.D6.E4-Z X33 |
| G | 1 | 339284 | 45A GRILLE, 4" ROUND WHITE CLOSABLE |
- INSTALLATION NOTES:**
- DO NOT INSTALL AIR CONDITIONER IN BILGE OR ENGINE ROOM AREAS. DO NOT TERMINATE CONDENSATE DRAIN LINE IN BILGE OR ANY AREA THAT MAY BE EXPOSED TO ENGINE OR GENERATOR EXHAUST FUMES. A/C UNIT MUST BE SEALED FROM ANY EXHAUST OR BILGE VAPORS.
 - INSTALL RETURN AIR GRILLE LOW AND SUPPLY AIR GRILLE HIGH.
 - SUPPLY AIR GRILLE SHOULD NOT BLOW TOWARD RETURN AIR GRILLE. DUCTING SHOULD BE INSTALLED AS SMOOTH AND TAUT AS POSSIBLE, TRIM ANY EXCESS, AVOID ANY UNNECESSARY BENDS OR LOOPS.

SEAWATER KIT INSTALLATION

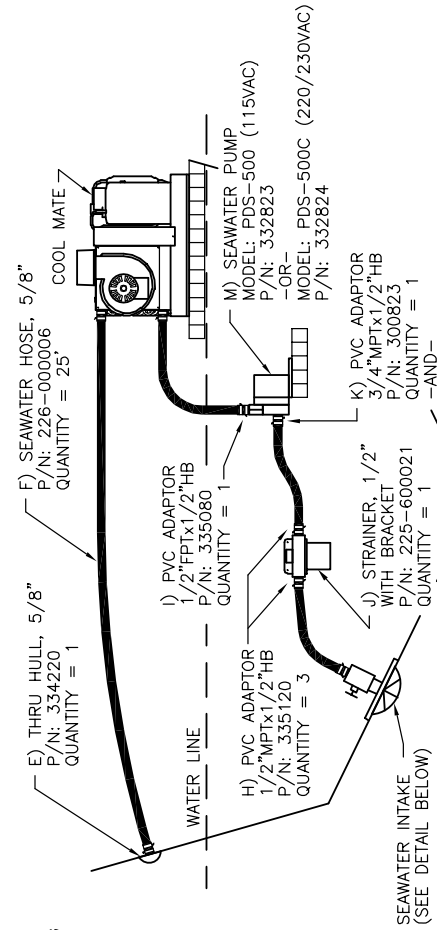

SEAWATER KIT:

LEGEND	QTY	P/N	DESCRIPTION
E	1	334220	THRU HULL, 5/8" PLASTIC
F	25'	226-000006	HOSE SEAWATER 5/8"
G	N/A	N/A	
H	3	335120	ADAPT, PVC 1/2" MPTx1/2" HB
I	1	335080	ADAPT, PVC 1/2" FPTx1/2" HB
J	1	225-600021	STRAINER W/BACKET 1/2" FPT
K	1	300823	ADAPT, PVC 3/4" MPTx1/2" HB
L	1	332724	COUPLING, PVC 3/4" FPTx3/4" FPT
M	1	332823	PUMP, PDS-500 115V SEAWATER
N	1	332824	PUMP, PDS-500C 220/230V SEAWATER
O	17	369617	CLAMP, HOSE #06SS THIN
P	1	330482	BALL VALVE, 1/2" SS HNDL (BRONZE)
Q	3	369699	STRAINER, SPEED SCOOP 1/2" BRONZE
R	6	336750	TERMINAL BUTT SPLICE 16-14 YELLOW

NOTES:

- SEAWATER SYSTEM MUST HAVE A STEADY UPWARD FLOW FROM INLET TO AIR CONDITIONER.
- HOSES MUST NOT HAVE KINKS, LOOPS OR HIGH SPOTS WHERE AIR CAN BE TRAPPED.
- PUMP AND STRAINER MUST BE BELOW WATER LINE. STRAINER MUST BE BELOW PUMP AND ABOVE INLET.
- SPEED SCOOP INLET SHOULD BE INSTALLED AS FAR BELOW THE WATER LINE AND AS CLOSE TO THE KEEL AS POSSIBLE, FACING FORWARD.
- AVOID OR MINIMIZE 90° BENDS OR ELBOWS AS MUCH AS POSSIBLE, ROTATE PUMP HEAD TOWARD DIRECTION OF WATER FLOW.
- ELECTRICAL CONNECTIONS USING ITEMS Q & R ARE TO BE DONE BY QUALIFIED PERSONNEL ONLY.

N) HOSE CLAMPS:

- ALL HOSE CONNECTIONS IN SEAWATER SYSTEM TO BE DOUBLE CLAMPED, HOSE CLAMPS TO BE REVERSED AS SHOWN
- H) PVC ADAPTOR 1/2" MPTx1/2" HB**
P/N: 335120
QUANTITY = 3
- O) BALL VALVE, 1/2"**
P/N: 330482
QUANTITY = 1
- BACKING PLATE (NOT INCLUDED)**
- BEDDING COMPOUND (APPLY LIBERALLY TO BOTH SIDES AND THROUGHOUT HOLE; NOT INCLUDED IN KIT.)**
- HULL**
- P) SPEED SCOOP, 1/2"**
P/N: 369699
QUANTITY = 1 (FACING FORWARD)

CLM16K DWG # M1030061D 10/13/03

Marine Air Worldwide Service Dealer Locator

The majority of the service listings displayed for the United States are key members of the national Marine Air distributor network. If you need service, please contact the closest company shown. In most cases they will direct you to a local dealer or service port. We have over 500 Marine Air dealers in the national Marine Air network, and one should be convenient to you.

The **international** companies listed are, in many cases, distributors and are capable of managing the majority of service requests for the countries listed. In some cases they will refer you to a local dealer.

You may also contact us directly via the web site or call us in the US at (954) 973-2477.

For a complete and up-to-date Dealer locator list, please visit our website at <http://www.marineair.com/locator/index.html>

USA

Alabama

AER Marine Supply

Location: Seabrook, Texas, USA
Phone: (281) 474-3276
Fax: (281) 474-2714
E-mail: rsmiller@aersupply.com
Web: www.aersupply.com

Alaska

American Marine Contractors

Location: Seattle, Washington, USA
Phone: (206) 660-2240
Fax: (206) 548-5008
E-mail: Cliff@nwmarineair.com

Arizona

Southern California Marine Enterprises

Location: San Diego, California, USA
Phone: 619-224-2869
Fax: 619-226-0496
E-mail: sales@southernmarine.com
Web: www.southernmarine.com

Arkansas

AER Marine Supply

Location: Seabrook, Texas, USA
Phone: (281) 474-3276
Fax: (281) 474-2714
E-mail: rsmiller@aersupply.com
Web: www.aersupply.com

California

Southern California Marine Enterprises

Location: San Diego, California, USA
Phone: 619-224-2869
Fax: 619-226-0496
E-mail: sales@southernmarine.com
Web: www.southernmarine.com

Colorado

AER Marine Supply

Location: Seabrook, Texas, USA
Phone: (281) 474-3276
Fax: (281) 474-2714
E-mail: rsmiller@aersupply.com
Web: www.aersupply.com

Connecticut

Ocean Options

Location: Tiverton, Rhode Island, USA
Phone: (401) 624-7334
Fax: (401) 624-8050
E-mail: Sales@oceanoptions.com
Web: www.oceanoptions.com

Delaware

Ocean Options - Mid Atlantic

Location: Annapolis, Maryland, USA
Phone: (410) 268-9365
Fax: (410) 268-8199
E-mail: Sales@oceanoptions.com
Web: www.oceanoptions.com

Florida, North & Panhandle

Beard Marine Savannah - Distributor

Location: Savannah, Georgia, USA
Phone: (912) 356-5222
Fax: (912) 692-1006
E-mail: infosavannah@beardmarine.com
Web: www.beardmarine.com

Florida, Southeast

A A Mabru, Inc. - Dealer

Location: Miami, Florida, USA
Territory: Pompano Beach
Phone: 305-634-8063
Fax: 305-634-0906
E-mail: mabru@mabru.com
Web: http://www.mabru.com/air_conditioning/

ARW/Heinen & Hopman - Dealer

Location: Ft. Lauderdale, Florida, USA
Territory: Fort Lauderdale
Phone: (954) 463-0110
Fax: (954) 522-1139
E-mail: info@arwmaritime.com
Web: www.heinenhopman.com

Beard Marine - Ft. Lauderdale - Dealer

Location: Ft. Lauderdale, Florida, USA
Territory: Fort Lauderdale
Phone: (954) 463-2288
Fax: (954) 527-0362
E-mail: info@beardmarine.com
Web: www.beardmarine.com

Beard Marine of the Palm Beaches - Dealer

Location: Riviera Beach, Florida, USA
Territory: Riviera Beach
Phone: (561) 881-9598
Fax: (561) 881-9599
E-mail: bmpb@beardmarine.com

Cable Marine - Dealer

Location: Ft. Lauderdale, Florida, USA
Territory: Fort Lauderdale
Phone: (954) 462-2840
Fax: (954) 523-3686
E-mail: eastvard@cablemarine.com
Web: www.cablemarine.com

Comfort Marine - Dealer

Location: Ft. Lauderdale, Florida, USA
Territory: Ft. Lauderdale
Phone: (954) 257-9848
Fax: (954) 689-7332

Cowherd Marine - Dealer

Location: Lake Park, Florida, USA
Territory: West Palm Beach
Phone: (561) 844-1666
Fax: (561) 844-1628
E-mail: cowherdmarine@adelphia.com

Florida, Southeast

Dometic Environmental Corporation, Distributor

Location: Pompano Beach, Florida, USA
Territory: South Florida
Phone: (954) 973-2477
Fax: (954) 979-4414
E-mail: sales@dometicenviro.com
Web: www.dometicenviro.com

Edd Helms Marine Air Conditioning - Dealer

Location: Miami, Florida, USA
Territory: Ft. Lauderdale, Miami
Phone: 954 522 2520
Fax: 954 522 1331
E-mail: srogers@eddhelms.com
Web: www.EddHelmsMarine.com

Marine Air Conditioning - Dealer

Location: Ft. Pierce, Florida, USA
Territory: Port St. Lucie
Phone: (772) 464-7896
Fax: (772) 464-8697

Masters Marine Center, Inc. - Dealer

Location: Miami, Florida, USA
Territory: Miami
Phone: (305) 871-7111
Fax: (305) 871-0214
E-mail: mastersmarine@aol.com

Neptune Air Corporation - Dealer

Location: Ft. Lauderdale, Florida, USA
Territory: Fort Lauderdale
Phone: (954) 779-2510
Fax: (954) 779-2732

Sea Air Land Technologies - Dealer

Location: Marathon, Florida, USA
Territory: Florida Keys
Phone: (305) 289-1150
Fax: (305) 289-0275
E-mail: saltmail@salt-systems.com
Web: www.salt-systems.com

Sea Breeze Marine - Dealer

Location: Lighthouse Point, Florida, USA
Territory: Lighthouse Point
Phone: (954) 427-3843
Fax: (561) 368-0463

Seafarer Marine Supply Inc

Location: Largo, Florida, USA
Territory: Tampa-St Petersburg
Phone: (727) 595-8813
Fax: (727) 595-5557
E-mail: ttomalo@aol.com

Florida, Southwest

Cruisair Suncoast, Inc.

Location: St. Petersburg, Florida, USA
Phone: 727-526-7875
Fax: 727-528-9519
E-mail: cruisairsuncoast@yahoo.com

Georgia

Beard Marine Savannah - Distributor

Location: Savannah, Georgia, USA
Phone: (912) 356-5222
Fax: (912) 692-1006
E-mail: infosavannah@beardmarine.com
Web: www.beardmarine.com

Hawaii

Southern California Marine Enterprises

Location: San Diego, California, USA
Phone: 619-224-2869
Fax: 619-226-0496
E-mail: sales@southernmarine.com
Web: www.southernmarine.com

Idaho

American Marine Contractors

Location: Seattle, Washington, USA
Phone: (206) 660-2240
Fax: (206) 548-5008
E-mail: Cliff@nwmarineair.com

Illinois

Midwest Marine Supply

Location: St. Clair Shores, Michigan, USA
Phone: (586) 778-8950
Fax: (586) 778-6108
E-mail: sales@midwestmarinesupply.com
Web: www.midwestmarinesupply.com

Indiana

Midwest Marine Supply

Location: St. Clair Shores, Michigan, USA
Phone: (586) 778-8950
Fax: (586) 778-6108
E-mail: sales@midwestmarinesupply.com
Web: www.midwestmarinesupply.com

Iowa

Midwest Marine Supply

Location: St. Clair Shores, Michigan, USA
Phone: (586) 778-8950
Fax: (586) 778-6108
E-mail: sales@midwestmarinesupply.com
Web: www.midwestmarinesupply.com

Kansas

AER Marine Supply

Location: Seabrook, Texas, USA
Phone: (281) 474-3276
Fax: (281) 474-2714
E-mail: rsmiller@aersupply.com
Web: www.aersupply.com

Kentucky

Midwest Marine Supply

Location: St. Clair Shores, Michigan, USA
Phone: (586) 778-8950
Fax: (586) 778-6108
E-mail: sales@midwestmarinesupply.com
Web: www.midwestmarinesupply.com

Louisiana

AER Marine Supply

Location: Seabrook, Texas, USA
Phone: (281) 474-3276
Fax: (281) 474-2714
E-mail: rsmiller@aersupply.com
Web: www.aersupply.com

Maine

Ocean Options

Location: Tiverton, Rhode Island, USA
Phone: (401) 624-7334
Fax: (401) 624-8050
E-mail: Sales@oceanoptions.com
Web: www.oceanoptions.com

Maryland

Ocean Options - Mid Atlantic

Location: Annapolis, Maryland, USA
Phone: (410) 268-9365
Fax: (410) 268-8199
E-mail: Sales@oceanoptions.com
Web: www.oceanoptions.com

Massachusetts

Ocean Options

Location: Tiverton, Rhode Island, USA
Phone: (401) 624-7334
Fax: (401) 624-8050
E-mail: Sales@oceanoptions.com
Web: www.oceanoptions.com

Michigan

Midwest Marine Supply

Location: St. Clair Shores, Michigan, USA
Phone: (586) 778-8950
Fax: (586) 778-6108
E-mail: sales@midwestmarinesupply.com
Web: www.midwestmarinesupply.com

Minnesota

Midwest Marine Supply

Location: St. Clair Shores, Michigan, USA
Phone: (586) 778-8950
Fax: (586) 778-6108
E-mail: sales@midwestmarinesupply.com
Web: www.midwestmarinesupply.com

Mississippi

AER Marine Supply

Location: Seabrook, Texas, USA
Phone: (281) 474-3276
Fax: (281) 474-2714
E-mail: rsmiller@aersupply.com
Web: www.aersupply.com

Missouri

AER Marine Supply

Location: Seabrook, Texas, USA
Phone: (281) 474-3276
Fax: (281) 474-2714
E-mail: rsmiller@aersupply.com
Web: www.aersupply.com

Montana

American Marine Contractors

Location: Seattle, Washington, USA
Phone: (206) 660-2240
Fax: (206) 548-5008
E-mail: Cliff@nwmarineair.com

Nevada

AER Marine Supply

Location: Seabrook, Texas, USA
Phone: (281) 474-3276
Fax: (281) 474-2714
E-mail: rsmiller@aersupply.com
Web: www.aersupply.com

New Hampshire

Ocean Options

Location: Tiverton, Rhode Island, USA
Phone: (401) 624-7334
Fax: (401) 624-8050
E-mail: Sales@oceanoptions.com
Web: www.oceanoptions.com

New Jersey

Marine Specialists

Location: Ronkonkoma, New York, USA
Territory: New York, New Jersey
Phone: (631) 580-0545
Fax: (631) 580-0551
E-mail: Sales@marinespecialists.com
Web: www.marinespecialists.com

New Mexico

AER Marine Supply

Location: Seabrook, Texas, USA
Phone: (281) 474-3276
Fax: (281) 474-2714
E-mail: rsmiller@aersupply.com
Web: www.aersupply.com

New York

Marine Specialists

Location: Ronkonkoma, New York, USA
Territory: New York, New Jersey
Phone: (631) 580-0545
Fax: (631) 580-0551
E-mail: Sales@marinespecialists.com
Web: www.marinespecialists.com

North Carolina

Beard Marine Savannah - Distributor

Location: Savannah, Georgia, USA
Phone: (912) 356-5222
Fax: (912) 692-1006
E-mail: infosavannah@beardmarine.com
Web: www.beardmarine.com

North Dakota

Midwest Marine Supply

Location: St. Clair Shores, Michigan, USA
Phone: (586) 778-8950
Fax: (586) 778-6108
E-mail: sales@midwestmarinesupply.com
Web: www.midwestmarinesupply.com

Ohio

Midwest Marine Supply

Location: St. Clair Shores, Michigan, USA
Phone: (586) 778-8950
Fax: (586) 778-6108
E-mail: sales@midwestmarinesupply.com
Web: www.midwestmarinesupply.com

Oklahoma

AER Marine Supply

Location: Seabrook, Texas, USA
Phone: (281) 474-3276
Fax: (281) 474-2714
E-mail: rsmiller@aersupply.com
Web: www.aersupply.com

Oregon

American Marine Contractors

Location: Seattle, Washington, USA
Phone: (206) 660-2240
Fax: (206) 548-5008
E-mail: Cliff@nwmarineair.com

Pennsylvania

Ocean Options - Mid Atlantic

Location: Annapolis, Maryland, USA
Phone: (410) 268-9365
Fax: (410) 268-8199
E-mail: Sales@oceanoptions.com
Web: www.oceanoptions.com

Rhode Island

Ocean Options

Location: Tiverton, Rhode Island, USA
Phone: (401) 624-7334
Fax: (401) 624-8050
E-mail: Sales@oceanoptions.com
Web: www.oceanoptions.com

South Carolina

Beard Marine Savannah - Distributor

Location: Savannah, Georgia, USA
Phone: (912) 356-5222
Fax: (912) 692-1006
E-mail: infosavannah@beardmarine.com
Web: www.beardmarine.com

South Dakota

Midwest Marine Supply

Location: St. Clair Shores, Michigan, USA
Phone: (586) 778-8950
Fax: (586) 778-6108
E-mail: sales@midwestmarinesupply.com
Web: www.midwestmarinesupply.com

Tennessee

Beard Marine Savannah - Distributor

Location: Savannah, Georgia, USA
Phone: (912) 356-5222
Fax: (912) 692-1006
E-mail: infosavannah@beardmarine.com
Web: www.beardmarine.com

Texas

AER Marine Supply

Location: Seabrook, Texas, USA
Phone: (281) 474-3276
Fax: (281) 474-2714
E-mail: rsmiller@aersupply.com
Web: www.aersupply.com

Utah

AER Marine Supply

Location: Seabrook, Texas, USA
Phone: (281) 474-3276
Fax: (281) 474-2714
E-mail: rsmiller@aersupply.com
Web: www.aersupply.com

Vermont

Ocean Options

Location: Tiverton, Rhode Island, USA
Phone: (401) 624-7334
Fax: (401) 624-8050
E-mail: Sales@oceanoptions.com
Web: www.oceanoptions.com

Virginia

Ocean Options - Mid Atlantic

Location: Annapolis, Maryland, USA
Phone: (410) 268-9365
Fax: (410) 268-8199
E-mail: Sales@oceanoptions.com
Web: www.oceanoptions.com

Washington

American Marine Contractors

Location: Seattle, Washington, USA
Phone: (206) 660-2240
Fax: (206) 548-5008
E-mail: Cliff@nwmarineair.com

West Virginia

Ocean Options - Mid Atlantic

Location: Annapolis, Maryland, USA
Phone: (410) 268-9365
Fax: (410) 268-8199
E-mail: Sales@oceanoptions.com
Web: www.oceanoptions.com

Wisconsin

Midwest Marine Supply

Location: St. Clair Shores, Michigan, USA
Phone: (586) 778-8950
Fax: (586) 778-6108
E-mail: sales@midwestmarinesupply.com
Web: www.midwestmarinesupply.com

Wyoming

American Marine Contractors

Location: Seattle, Washington, USA
Phone: (206) 660-2240
Fax: (206) 548-5008
E-mail: Cliff@nwmarineair.com

Argentina

Baron SRL

Location: San Fernando, Buenos Aires, Argentina
Phone: (54) 11-4-580-5556
Fax: (54) 11-4-746-1696
E-mail: rosito@baron.com.ar
Web: www.baron.com.ar

Australia

Seairland Systems, Inc.

Location: Brisbane, Queensland, Australia
Phone: (61) 7-3268-7511
Fax: (61) 7-3268-1445
E-mail: hadyn@seairland.com.au

Austria

Domestic Marine – Italy, Sales Company

Location: Milano, Italy
Phone: 39 0362 44182
Fax: 39 0362 452226
E-mail: marine.info@dometic.it
Web: www.dometic.com

Bahamas

Bradford Grand Bahama, Ltd.

Location: Freeport, Grand Bahama, Bahamas
Phone: +242-352-7711
Fax: +242-352-7695
E-mail: dan@bradford-grand-bahama.com
Web: www.bradford-grand-bahama.com

Freezing Point, Ltd.

Location: Nassau, Bahamas
Territory: Nassau
Phone: (242) 325-3589
Fax: (242) 356-5271
E-mail: rolandknowles@bahamas.net.bs

Bahrain

International Agencies Co.

Location: Manama, Bahrain
Phone: 973-17728691
Fax: 973-17728412

Mantech

Location: Dubai, United Arab Emirates
Phone: +(971) 4-3332-542
Fax: +(971) 4-3330-649
E-mail: mqe@emirates.net.ae

Brazil

Marine Express

Location: Sao Paulo, Brazil
Phone: 55-11-5182-7166
Fax: 55-11-5183-3636
E-mail: fabrizio@marineexpress.com.br
Web: www.marineexpress.com.br

British Virgin Islands

BVI Marine Management

Location: Roadtown, Tortola, British Virgin Islands
Phone: (284) 494-2938
Fax: (284) 494-5006
E-mail: rescuer1@surfbvi.com

C & G Refrigeration

Location: , Tortola, British Virgin Islands
Phone: (284) 776-0038

Parts And Power

Location: Tortola, British Virgin Islands
Phone: 284-494-2830
Fax: 284-494-1584
E-mail: info@partsandpower.com
Web: www.partsandpower.com

British West Indies

Caribbean Marine & Diesel

Location: Turks and Caicos Islands, British West Indies
Phone: 649-941-5903
Fax: 649-941-5902
E-mail: caribmarinediesel@tcwayway.tc

Canada

British Columbia

American Marine Contractors

Location: Seattle, Washington, USA
Phone: (206) 660-2240
Fax: (206) 548-5008
E-mail: Cliff@nwmarineair.com

Ontario

Northland Supply Company

Location: Queensville, Ontario, Canada
Territory: Queensville
Phone: (905) 478-2244
Fax: (905) 478-2295
E-mail: norsupco@aol.com
Web: www.norsupco.com

Woodard and Company - Manufacturer's Rep.

Location: Concord, Ontario, Canada
Territory: All Canadian Provinces except BC
Phone: (905)760-0245
Fax: (905)760-0250
E-mail: john.reid@woodardcompany.com

Quebec

Kimpex, Inc.

Location: Drummondville, Quebec, Canada
Territory: Drummondville, Quebec
Phone: (705) 721-0947
Fax: (705) 721-1704
E-mail: scott.pipher@kpx-kimpex.com
Web: http://www.kpx-kimpex.com

Caribbean Islands

BVI Marine Management

Location: Roadtown, Tortola, British Virgin Islands
Phone: (284) 494-2938
Fax: (284) 494-5006
E-mail: rescuer1@surfbvi.com

C & G Refrigeration

Location: , Tortola, British Virgin Islands
Phone: (284) 776-0038

Caraipe Greemant

Location: Le Marin, Martinique, French West Indies
Phone: 596 596 74 80 33
E-mail: cqmar@wanadoo.fr

Caribbean Marine & Diesel

Location: Turks and Caicos Islands, British West Indies
Phone: 649-941-5903
Fax: 649-941-5902
E-mail: caribmarinediesel@tcwayway.tc

Centro Cruisair de Puerto Rico

Location: Santurce, Puerto Rico
Phone: 787-727-3637
Fax: 787-727-3637
E-mail: fernan_moreno@hotmail.com

Cool-Tech Air Condition

Location: Fajardo, Puerto Rico
Phone: (787) 860-2615
Fax: (787) 801-2050
Web: http://www.cooltechac.com/

Enertech N.V.

Location: Simpson Bay, St. Maarten/St. Martin, Netherlands Antilles
Phone: +599-551-2145
Fax: +599-544-4608
E-mail: service@enertechnv.com
Web: www.enertechnv.com

Freezing Point, Ltd.

Location: Nassau, Bahamas
Territory: Nassau
Phone: (242) 325-3589
Fax: (242) 356-5271
E-mail: rolandknowles@bahamas.net.bs

Frostline

Location: Cole Bay, St. Maarten/St. Martin, Netherlands Antilles
Phone: 599 522 9610 (Technical)
Fax: 599 544 3263
E-mail: paul@frostline.biz (technical); glyn@frostline.biz

May Day Marine

Location: San Juan, Puerto Rico
Phone: 787-637-0756
Fax: 787-790-2551

Nau-T-Kol Marine Refrigeration

Location: Chaguaramas, Trinidad
Phone: 868-634-2174
Fax: 868-634-2174
E-mail: nautkol@cablenett.net
Web: www.nautkol.com

Reefco, Inc.

Location: , St. Thomas, US Virgin Islands
Phone: (340) 776-0038
Fax: (340) 776-0038
E-mail: dennedy@viaccess.net
Web: www.reefco.net

Regis Electronics (St Lucia) LTD.

Location: St. Lucia, West Indies
Phone: 758-452-0205
Fax: 758-452-0206
E-mail: stlucia@regiselectronics.com
Web: www.regiselectronics.com

Suncool Air Conditioning

Location: Carolina, Puerto Rico, Puerto Rico
Territory: Carolin
Phone: (787) 791-6971
Fax: (787) 791-3885
E-mail: suncool1@coqui.net

The Signal Locker

Location: English Harbour, Antigua, West Indies
Territory: Antigua
Phone: (268) 460-1528
Fax: (268) 460-1148
E-mail: lockers@candw.aq

China

Flash Marine Trading Pte.Ltd.

Location: Shanghai, China
Phone: (86 21) 509 04120
Fax: (86 21) 509 04789
E-mail: fntmasb@online.sh.cn

Columbia

Todomar CHL Marina S.A.

Location: Cartagena, Colombia
Phone: +57-5-6654177
Fax: +57-5-6655118
E-mail: flondono@todomarchl.com

Costa Rica

CR Marine Supply S.A.

Location: Garrabito, Costa Rica
Territory: Costa Rica
Phone: 506-637-7419
Fax: 506-637-7180
E-mail: info@cmarinesupply.com

Croatia

Domestic Marine – Italy, Sales Company

Location: Milano, Italy
Phone: 39 0362 44182
Fax: 39 0362 452226
E-mail: marine.info@dometic.it
Web: www.dometic.com

Cyprus

Domestic Marine - United Kingdom, Sales Company

Location: Poole, Dorset, England
Phone: 44 870 3306101
Fax: 44 870 3306102
E-mail: sales@dometicmarine.com
Web: www.dometic.com

Dominican Republic

May Day Marine

Location: San Juan, Puerto Rico
Phone: 787-637-0756
Fax: 787-790-2551

Ecuador

Quasar Nautica, S.A.

Location: P.O. Box 17-01-0069, Quito, Ecuador
Phone: (593) 2-446-996/997
Fax: (593) 2-436-625

Egypt

Engineering Air

Location: Abasia, Cairo, Egypt
Phone: 202 4829341
Fax: 202 4829341

France

Domestic Marine – France, Sales Company

Location: Plailly, France
Phone: Cell: 0033 (0)680 415 543
Fax: 0033 (0)344 633 518
E-mail: marine.sales@dometic.fr
Web: www.dometic.com

PolyMarine Distribution (C/O Occas Marine)

Location: Le Cannet, Rocheville, France
Phone: 0033 493463634
Fax: 0033 493463634
E-mail: polymarine.bayle@free.fr

French West Indies

Caraibe Greemart

Location: Le Marin, Martinique, French West Indies
Phone: 596 596 74 80 33
E-mail: cqmar@wanadoo.fr

Greece

Domestic Marine - United Kingdom, Sales Company

Location: Poole, Dorset, England
Phone: 44 870 3306101
Fax: 44 870 3306102
E-mail: sales@dometicmarine.com
Web: www.dometic.com

Athens

Aegean Diesel Electric Ltd.

Location: Athens, Piraeus, Greece
Territory: Athens
Phone: +30 210 42 22 484
Fax: +30 210 41 75 201
E-mail: info@ade-marine.gr

Hong Kong

Piercey Marine Limited

Location: Sai Kung, NT, Hong Kong
Phone: (852) 2791-4106
Fax: (852) 2791-4124
E-mail: pmltd@netvigator.com

Italy

Condaria 87 SRL

Location: Nova Milanese (MI), Italy
Phone: 39 0362 44182
Fax: 39 0362 452226
E-mail: condaria@tin.it

Domestic Marine – Italy, Sales Company

Location: Milano, Italy
Phone: 39 0362 44182
Fax: 39 0362 452226
E-mail: marine.info@dometic.it
Web: www.dometic.com

Japan

Tominaga & Company, Ltd.

Location: Osaka, Japan
Phone: 816.6365.5010
Fax: 816.6365.6294
E-mail: nishi@mail.tomco.co.jp

Kuwait

Mantech

Location: Dubai, United Arab Emirates
Phone: +(971) 4-3332-542
Fax: +(971) 4-3330-649
E-mail: mge@emirates.net.ae

Sammari Marine Trading

Location: Al-Shawikh, Kuwait
Phone: 965-5740408
Fax: 965-5715655

Malta

Domestic Marine - United Kingdom, Sales Company

Location: Poole, Dorset, England
Phone: 44 870 3306101
Fax: 44 870 3306102
E-mail: sales@dometicmarine.com
Web: www.dometic.com

Inmartech Ltd.

Location: Swieqi, STJ 04, Malta
Phone: 00356 21376476
Fax: 00356 21376476
E-mail: inmartech@waldonet.net.mt

Mexico

Southern California Marine Enterprises

Location: San Diego, California, USA
Phone: 619-224-2869
Fax: 619-226-0496
E-mail: sales@southernmarine.com
Web: www.southernmarine.com

Netherlands

Eberca

Location: , Netherlands
Phone: 31 1866 21955
Fax: 31 1866 21818
E-mail: info@eberca.nl

Heinen & Hopman Eng. Bv.

Location: Spakenburg, Netherlands
Phone: (31) (0) 33 2992500
Fax: (31) (0) 33 299 2599
E-mail: info@heinenhopman.com
Web: www.heinenhopman.com

Netherlands Antilles

Enertech N.V.

Location: Simpson Bay, St. Maarten/St. Martin, Netherlands Antilles
Phone: +599-551-2145
Fax: +599-544-4608
E-mail: service@enertechnv.com
Web: www.enertechnv.com

Frostline

Location: Cole Bay, St. Maarten/St. Martin, Netherlands Antilles
Phone: 599 522 9610 (Technical)
Fax: 599 544 3263
E-mail: paul@frostline.biz (technical); glyn@frostline.biz

New Zealand

Whiting Power Systems

Location: 192 Herne Bay, Auckland, New Zealand
Phone: 649.358.2050
Fax: 649.358.0285
E-mail: sales@whiting.co.nz
Web: www.whiting.co.nz

Oman

Mantech

Location: Dubai, United Arab Emirates
Phone: +(971) 4-3332-542
Fax: +(971) 4-3330-649
E-mail: mae@emirates.net.ae

OHI Marine LLC

Location: Muscat, Oman
Phone: 968-712240
Fax: 968-712085

Pakistan

Breeze Marketing

Location: Karachi, Pakistan
Phone: +(92-21) 5883662, 5380735 & 5883824
Fax: +(92-21) 5883813
E-mail: m-a@cyber.net.pk

Mantech

Location: Dubai, United Arab Emirates
Phone: +(971) 4-3332-542
Fax: +(971) 4-3330-649
E-mail: mae@emirates.net.ae

Panama

Evans International Services SA

Location: Panama City, Panama
Territory: Panama
Phone: 507-232-5406
Fax: 507-232-7648
E-mail: info@evansint.com
Web: www.evansint.com

Panama Yacht Sales and Service

Location: Panama City, Panama
Phone: 507-314-3345
Fax: 507-314-3346
E-mail: info@panamayachtsales.com

Productos Marine Air

Location: La Chorra, Panama
Territory: Panama
Phone: 507-232-5406
Fax: 507-232-7648
E-mail: masters@sinfo.net

Peru

Corporación Frío Novo SAC

Location: Lima (La Molina), Peru
Phone: (511) 451-5052
E-mail: frionovo@infonegocio.net.pe

Portugal

PowerCool LDA

Location: Portimao, Portugal
Territory: Portugal
Phone: 351 91 786 63 73
Fax: 351 282 461 818
E-mail: info@powercool.org
Web: www.powercool.org

Puerto Rico

Centro Cruisair de Puerto Rico

Location: Santurce, Puerto Rico
Phone: 787-727-3637
Fax: 787-727-3637
E-mail: ferman_moreno@hotmail.com

Cool-Tech Air Condition

Location: Fajardo, Puerto Rico
Phone: (787) 860-2615
Fax: (787) 801-2050
Web: http://www.cooltechac.com/

May Day Marine

Location: San Juan, Puerto Rico
Phone: 787-637-0756
Fax: 787-790-2551

Suncool Air Conditioning

Location: Carolina, Puerto Rico, Puerto Rico
Territory: Carolin
Phone: (787) 791-6971
Fax: (787) 791-3885
E-mail: suncool1@coqui.net

Qatar

Al-Badi Trading Co.

Location: Doha, Qatar
Phone: 974-4320715
Fax: 974-4442888
E-mail: albadi@qatar.net.qa

Mantech

Location: Dubai, United Arab Emirates
Phone: +(971) 4-3332-542
Fax: +(971) 4-3330-649
E-mail: mge@emirates.net.ae

Russia

Standarte

Location: Starbevo, Moscow region, Russia
Phone: 7 095 575 67 23
Fax: 7 095 575 39 77
E-mail: info@standarte.ru
Web: www.standarte.ru

Saudi Arabia

Mantech

Location: Dubai, United Arab Emirates
Phone: +(971) 4-3332-542
Fax: +(971) 4-3330-649
E-mail: mge@emirates.net.ae

Samaco Marine Division

Location: Alnahdah dis Jeddah, Saudi Arabia
Territory: Saudi Arabia
Phone: (966) 2-699-2300
Fax: (966) 2-699-1024

Scandinavia

Dometic Marine – Nordic Sales, Sales Company

Location: Halmstad, Sweden
Phone: 46 35165700
Fax: 46 35165710
E-mail: marine.info@dometic.se
Web: www.dometic.com

Singapore

Tripower Corporation Pte Ltd

Location: , Singapore
Phone: (65) 6861 1188
Fax: (65) 6861 4263
E-mail: mgt@tritex.com.sg; mgt@tripower.com.sg
Web: www.tritex.com.sg

Slovenia

Dometic Marine – Italy, Sales Company

Location: Milano, Italy
Phone: 39 0362 44182
Fax: 39 0362 452226
E-mail: marine.info@dometic.it
Web: www.dometic.com

South Africa

C-Dynamics cc

Location: Cape Town, South Africa
Phone: 27 21 555 3232
Fax: 27 21 555 3230
E-mail: info@c-dynamics.co.za
Web: www.c-dynamics.co.za

Spain

Acastimar

Location: Tarragona, Spain
Phone: 349-77-362118
Fax: 349-77-362687
E-mail: acastimar@acastimar.com

Dometic Marine – France, Sales Company

Location: Plailly, France
Phone: Cell: 0033 (0)680 415 543
Fax: 0033 (0)344 633 518
E-mail: marine.sales@dometic.fr
Web: www.dometic.com

Techno Electronica Naval, S.A.

Location: Barcelona, Spain
Phone: 34 (93) 664-49-70
Fax: 34 (93) 665-76-26
E-mail: ten@ten-sa.com
Web: www.ten-sa.com

Sri Lanka

G&M Enterprises

Location: Borella-Colombo 8, Sri Lanka
Phone: 94 11 2691966
Fax: 94 11 2691751
E-mail: gandM@sltnet.lk

Sweden

Dometic Marine – Nordic Sales, Sales Company

Location: Halmstad, Sweden
Phone: 46 35165700
Fax: 46 35165710
E-mail: marine.info@dometic.se
Web: www.dometic.com

Taiwan

Kaohsiung

Mercury Marine Supply Co.

Location: Kaohsiung, 812, Taiwan
Territory: Taiwan
Phone: (886) 7-8133233
Fax: (886) 7-8133236
E-mail: mms46654@ms16.hinet.net

Thailand

Thai Kolon Co. Ltd.

Location: Bangkok, Thailand
Phone: 66-2-745-6468-77 (10 lines)
Fax: 66-2-745-6152
E-mail: thaikolon@thaikolon.co.th
Web: www.thaikolon.com

Trinidad

Nau-T-Kol Marine Refrigeration

Location: Chaguaramas, Trinidad
Phone: 868-634-2174
Fax: 868-634-2174
E-mail: nautkol@cablenett.net
Web: www.nautkol.com

Turkey

Dometic Marine - United Kingdom, Sales Company

Location: Poole, Dorset, England
Phone: 44 870 3306101
Fax: 44 870 3306102
E-mail: sales@dometicmarine.com
Web: www.dometic.com

Egemar Muhendislik Ltd.

Location: Tuzla, Istanbul, Turkey
Phone: 90 216 494 2168
Fax: 90 216 494 2218
E-mail: sales@egemar.com.tr
Web: www.egemar.com.tr

U.S. Virgin Islands

Reefco, Inc.

Location: , St. Thomas, US Virgin Islands
Phone: (340) 776-0038
Fax: (340) 776-0038
E-mail: dennedy@viaccess.net
Web: www.reefco.net

Ukraine

Standarte

Location: Starbevo, Moscow region, Russia
Phone: 7 095 575 67 23
Fax: 7 095 575 39 77
E-mail: info@standarte.ru
Web: www.standarte.ru

United Arab Emirates

Mantech

Location: Dubai, United Arab Emirates
Phone: +(971) 4-3332-542
Fax: +(971) 4-3330-649
E-mail: mqe@emirates.net.ae

United Kingdom

Dometic Marine - United Kingdom, Sales Company

Location: Poole, Dorset, England
Phone: 44 870 3306101
Fax: 44 870 3306102
E-mail: sales@dometicmarine.com
Web: www.dometic.com

Uruguay

Baron SRL

Location: San Fernando, Buenos Aires, Argentina
Phone: (54) 11-4-580-5556
Fax: (54) 11-4-746-1696
E-mail: rosito@baron.com.ar
Web: www.baron.com.ar

Venezuela

Rich Marine Center

Location: Complejo Turistico El Morro, Venezuela, South America
Phone: (58) 281 2181630
Fax: (58) 281-2811630
E-mail: richmarine@telcel.net.ve

West Indies

Regis Electronics (St Lucia) LTD.

Location: St. Lucia, West Indies
Phone: 758-452-0205
Fax: 758-452-0206
E-mail: stlucia@requisellectronics.com
Web: www.regiselectronics.com

Antigua

The Signal Locker

Location: English Harbour, Antigua, West Indies
Territory: Antigua
Phone: (268) 460-1528
Fax: (268) 460-1148
E-mail: lockers@candw.ag

Yemen

Mantech

Location: Dubai, United Arab Emirates
Phone: +(971) 4-3332-542
Fax: +(971) 4-3330-649
E-mail: mqe@emirates.net.ae



Dometic Environmental Corporation

2000 N. Andrews Ave. Ext. • Pompano Beach, FL 33069 USA

Phone: 954-973-2477 • Facsimile: 954-979-4414 • www.marineair.com • sales@marineair.com

United States & Canada Service Only:

8:00 AM to 5:00 PM Eastern Time: 954-973-2477

24/7 A/C SERVICE HOTLINE: 5:00PM to 8:00 AM: 888-440-4494

International Sales & Service:

Europe & the Middle East: Call +44(0)870-330-6101

For all other areas visit our website to find your nearest distributor.