



Flange Dimensions Tolerances and Weights

TABLE OF CONTENTS

ANSI B16.5 CLASS 150# - 2500# FORGED FLANGES	3
B16.47 SERIES A CLASS 150# - 900# WELD NECK & BLIND	10
B16.47 SERIES B CLASS 75# - 900# WELD NECK & BLIND	15
BREW QUALITY FLANGES	21
BOLT AND STUD DIMENSIONS ASME B16.5.....	22
CLASS 125LW (175-150 PSI*) SAME AS AWWA CLASS D HUB	23
CLASS 125 WN.....	25
INDUSTRY STANDARD CLASS 75 SLIP-ON & BLIND	27
JACK SCREW SIZES FOR ORIFICE FLANGES	32
AWWA STANDARD STEEL-RING FLANGE	33
CLASS 150# - 2500# LONG WELD NECK.....	39
CLASS 150# - 2500# STUDDING OUTLETS.....	46
WALL THICKNESSES	52
WELD NECK FLANGE BORES.....	53
DIMENSIONS OF RING-JOINT FACINGS	54
TOLERANCES: ASME B16.5	56
FLANGE WEIGHTS.....	57

ANSI B16.5 Class 150 Forged Flanges

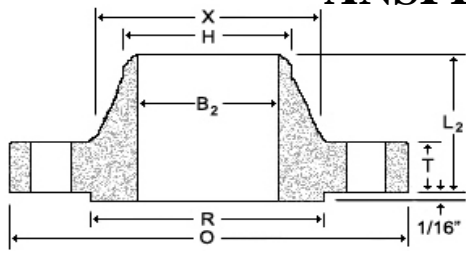

Weld Neck

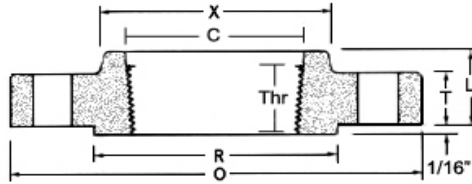

Threaded

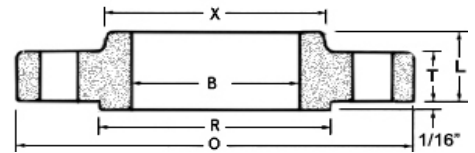

Slip-On

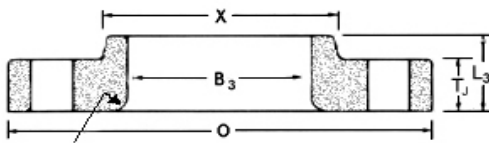

Lap Joint

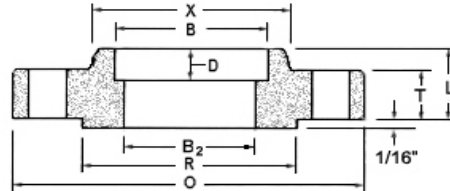

Socket Weld

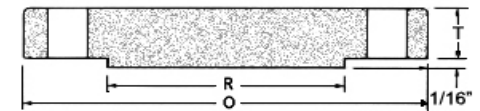

Blind

Nom. Pipe Size	O	T	T _J	R	X	#/Dia of Holes ^a	Bolt Circle Dia	B	B ₂ ^b	B ₃	H	L	L ₂	L ₃ ^c	r	D	Thr
½	3.50	0.38	0.44	1.38	1.19	4-0.62	2.38	0.88	0.62	0.90	0.84	0.56	1.81	0.62	0.12	0.38	0.62
¾	3.88	0.44	0.50	1.69	1.50	4-0.62	2.75	1.09	0.82	1.11	1.05	0.56	2.00	0.62	0.12	0.44	0.62
1	4.25	0.50	0.56	2.00	1.94	4-0.62	3.12	1.36	1.05	1.38	1.32	0.62	2.12	0.69	0.12	0.50	0.69
1¼	4.62	0.56	0.62	2.50	2.31	4-0.62	3.50	1.70	1.38	1.72	1.66	0.75	2.19	0.81	0.19	0.56	0.81
1½	5.00	0.62	0.69	2.88	2.56	4-0.62	3.88	1.95	1.61	1.97	1.90	0.81	2.38	0.88	0.25	0.62	0.88
2	6.00	0.69	0.75	3.62	3.06	4-0.75	4.75	2.44	2.07	2.46	2.38	0.94	2.44	1.00	0.31	0.69	1.00
2½	7.00	0.81	0.88	4.12	3.56	4-0.75	5.50	2.94	2.47	2.97	2.88	1.06	2.69	1.12	0.31	0.75	1.12
3	7.50	0.88	0.94	5.00	4.25	4-0.75	6.00	3.57	3.07	3.60	3.50	1.12	2.69	1.19	0.38	0.81	1.19
3½	8.50	0.88	0.94	5.50	4.81	8-0.75	7.00	4.07	3.55	4.10	4.00	1.19	2.75	1.25	0.38	0.88	1.25
4	9.00	0.88	0.94	6.19	5.31	8-0.75	7.50	4.57	4.03	4.60	4.50	1.25	2.94	1.31	0.44	0.94	1.31
5	10.00	0.88	0.94	7.31	6.44	8-0.88	8.50	5.66	5.05	5.69	5.56	1.38	3.44	1.44	0.44	0.94	1.44
6	11.00	0.94	1.00	8.50	7.56	8-0.88	9.50	6.72	6.07	6.75	6.63	1.50	3.44	1.56	0.50	1.06	1.56
8	13.50	1.06	1.12	10.62	9.69	8-0.88	11.75	8.72	7.98	8.75	8.63	1.69	3.94	1.75	0.50	1.25	1.75
10	16.00	1.12	1.19	12.75	12.00	12-1.00	14.25	10.88	10.02	10.92	10.75	1.88	3.94	1.94	0.50	1.31	1.94
12	19.00	1.19	1.25	15.00	14.38	12-1.00	17.00	12.88	12.00	12.92	12.75	2.12	4.44	2.19	0.50	1.56	2.19
14	21.00	1.31	1.38	16.25	15.75	12-1.12	18.75	14.14	13.25	14.18	14.00	2.19	4.94	3.12	0.50	1.63	2.25
16	23.50	1.38	1.44	18.50	18.00	16-1.12	21.25	16.16	15.25	16.19	16.00	2.44	4.94	3.44	0.50	1.75	2.50
18	25.00	1.50	1.56	21.00	19.88	16-1.25	22.75	18.18	17.25	18.20	18.00	2.62	5.44	3.81	0.50	1.94	2.69
20	27.50	1.62	1.69	23.00	22.00	20-1.25	25.00	20.20	19.25	20.25	20.00	2.81	5.62	4.06	0.50	2.13	2.88
22	29.50	1.75	1.81	25.25	24.25	20-1.38	27.25	22.22	21.25	22.25	22.00	3.07	5.82	4.25	0.50	2.38	3.13
24	32.00	1.81	1.88	27.25	26.12	20-1.38	29.50	24.25	23.25	24.25	24.00	3.19	5.94	4.38	0.50	2.50	3.25

Dimensions are in inches.

(a)- Bolt hole diameter 1/8 in. larger than bolt diameter.

(b)- Standard bore dimensions provided. See bore chart for other wall thicknesses.

(c)- This dimension is commonly associated with "true" lap joints. Industry standard is to make to the slip on length through the hub.

ANSI B16.5 Class 300 Forged Flanges

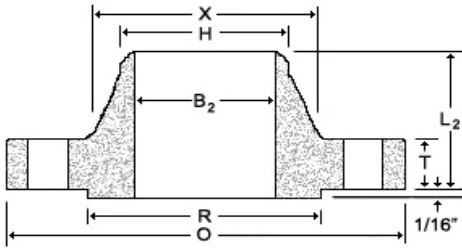

Weld Neck

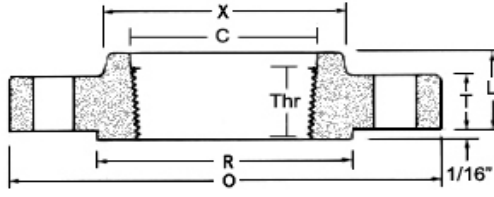

Threaded

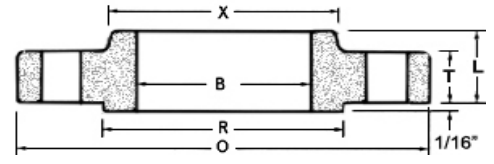

Slip-On

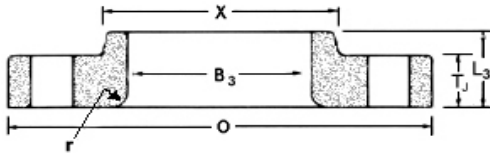

Lap Joint

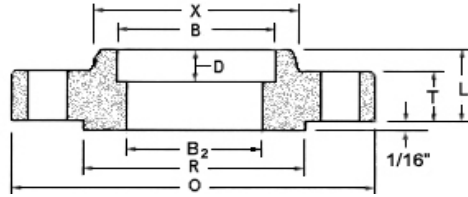

Socket Weld

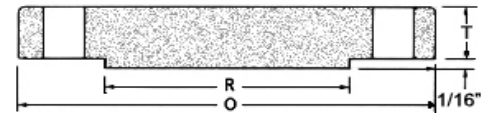

Blind

Nom. Pipe Size	O	T	TJ	R	X	#/Dia of Holes a	Bolt Circle Dia	B	B2 ^b	B3	H	L	L2	L3 ^c	r	C	D	Thr
1/2	3.75	0.50	0.56	1.38	1.50	4-0.63	2.62	0.88	0.62	0.90	0.84	0.81	2.00	0.88	0.12	0.93	0.38	0.62
3/4	4.62	0.56	0.62	1.69	1.88	4-0.75	3.25	1.09	0.82	1.11	1.05	0.94	2.19	1.00	0.12	1.14	0.44	0.62
1	4.88	0.62	0.69	2.00	2.12	4-0.75	3.50	1.36	1.05	1.38	1.32	1.00	2.38	1.06	0.12	1.41	0.50	0.69
1 1/4	5.25	0.69	0.75	2.50	2.50	4-0.75	3.88	1.70	1.38	1.72	1.66	1.00	2.50	1.06	0.19	1.75	0.56	0.81
1 1/2	6.12	0.75	0.81	2.88	2.75	4-0.88	4.50	1.95	1.61	1.97	1.90	1.13	2.63	1.19	0.25	1.98	0.62	0.88
2	6.50	0.81	0.88	3.62	3.31	8-0.75	5.00	2.44	2.07	2.46	2.38	1.25	2.69	1.31	0.31	2.50	0.69	1.12
2 1/2	7.50	0.94	1.00	4.12	3.94	8-0.88	5.88	2.94	2.47	2.97	2.88	1.44	2.94	1.50	0.31	3.00	0.75	1.25
3	8.25	1.06	1.12	5.00	4.62	8-0.88	6.62	3.57	3.07	3.60	3.50	1.63	3.06	1.69	0.38	3.63	0.81	1.25
3 1/2	9.00	1.12	1.19	5.50	5.25	8-0.88	7.25	4.07	3.55	4.10	4.00	1.69	3.13	1.75	0.38	4.13	1.44
4	10.00	1.19	1.25	6.19	5.75	8-0.88	7.88	4.57	4.03	4.60	4.50	1.82	3.32	1.88	0.44	4.63	1.44
5	11.00	1.31	1.38	7.31	7.00	8-0.88	9.25	5.66	5.05	5.69	5.56	1.94	3.82	2.00	0.44	5.69	1.69
6	12.50	1.38	1.44	8.50	8.12	12-0.88	10.62	6.72	6.07	6.75	6.63	2.00	3.82	2.06	0.50	6.75	1.81
8	15.00	1.56	1.62	10.62	10.25	12-1.00	13.00	8.72	7.98	8.75	8.63	2.38	4.32	2.44	0.50	8.75	2.00
10	17.50	1.81	1.88	12.75	12.62	16-1.12	15.25	10.88	10.02	10.92	10.75	2.56	4.56	3.75	0.50	10.88	2.19
12	20.50	1.94	2.00	15.00	14.75	16-1.25	17.75	12.88	12.00	12.92	12.75	2.82	5.06	4.00	0.50	12.94	2.38
14	23.00	2.06	2.12	16.25	16.75	20-1.25	20.25	14.14	13.25	14.18	14.00	2.94	5.56	4.38	0.50	14.19	2.50
16	25.50	2.19	2.25	18.50	19.00	20-1.38	22.50	16.16	15.25	16.19	16.00	3.19	5.69	4.75	0.50	16.19	2.69
18	28.00	2.31	2.38	21.00	21.00	24-1.38	24.75	18.18	17.25	18.20	18.00	3.44	6.19	5.12	0.50	18.19	2.75
20	30.50	2.44	2.50	23.00	23.12	24-1.38	27.00	20.20	19.25	20.25	20.00	3.69	6.32	5.50	0.50	20.19	2.88
22	33.00	2.57	2.63	25.25	25.25	24-1.63	29.25	22.22	21.25	22.25	22.00	3.93	6.43	5.75	0.50	22.19	3.13
24	36.00	2.69	2.75	27.25	27.62	24-1.63	32.00	24.25	23.25	24.25	24.00	4.13	6.56	6.00	0.50	24.19	3.25

Dimensions are in inches.

- (a)- Bolt hole diameter 1/8 in. larger than bolt diameter.
- (b)- Standard bore dimensions provided. See bore chart for other wall thicknesses.
- (c)- This dimension is commonly associated with "true" lap joints. Industry standard is to make to the slip on length through the hub.

ANSI B16.5 Class 400 Forged Flanges

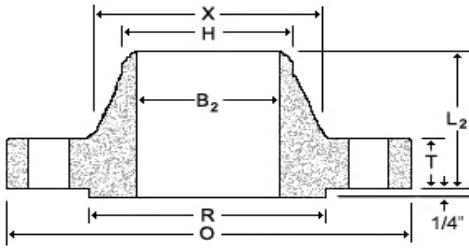

Weld Neck

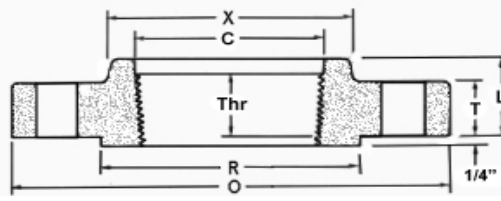

Threaded

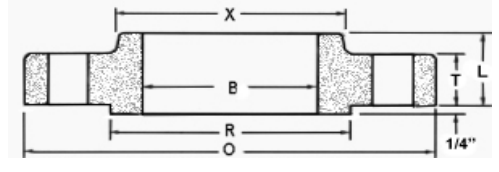

Slip-On

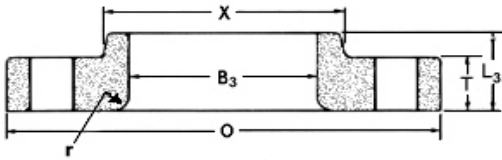

Lap Joint

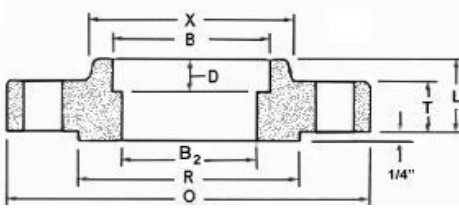

Socket Weld

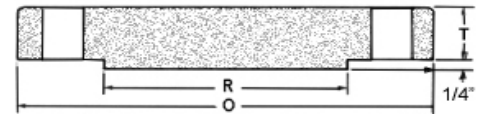

Blind

Nom. Pipe Size	O	T	R	X	#/Dia of Holes a	Bolt Circle Dia	B	B2 ^b	B3	H	L	L2	L3 ^c	r	C	D	Thr
1/2	3.75	0.56	1.38	1.50	4-0.63	2.62	0.88	To be specified by Purchaser.	0.90	0.84	0.88	2.06	0.88	0.12	0.93	0.38	0.62
3/4	4.62	0.62	1.69	1.88	4-0.75	3.25	1.09		1.11	1.05	1.00	2.25	1.00	0.12	1.14	0.44	0.62
1	4.88	0.69	2.00	2.12	4-0.75	3.50	1.36		1.38	1.32	1.06	2.44	1.06	0.12	1.41	0.50	0.69
1 1/4	5.25	0.81	2.50	2.50	4-0.75	3.88	1.70		1.72	1.66	1.12	2.62	1.12	0.19	1.75	0.56	0.81
1 1/2	6.12	0.88	2.88	2.75	4-0.88	4.50	1.95		1.97	1.90	1.25	2.75	1.25	0.25	1.99	0.62	0.88
2	6.50	1.00	3.62	3.31	8-0.75	5.00	2.44		2.46	2.38	1.44	2.88	1.44	0.31	2.50	0.69	1.12
2 1/2	7.50	1.12	4.12	3.94	8-0.88	5.88	2.94		2.97	2.88	1.62	3.12	1.62	0.31	3.00	0.75	1.25
3	8.25	1.25	5.00	4.62	8-0.88	6.62	3.57		3.60	3.50	1.81	3.25	1.81	0.38	3.63	0.81	1.38
3 1/2	9.00	1.38	5.50	5.25	8-1.00	7.25	4.07		4.10	4.00	1.94	3.38	1.94	0.38	4.13	1.56
4	10.00	1.38	6.19	5.75	8-1.00	7.88	4.57		4.60	4.50	2.00	3.50	2.00	0.44	4.63	1.44
5	11.00	1.50	7.31	7.00	8-1.00	9.25	5.66		5.69	5.56	2.12	4.00	2.12	0.44	5.69	1.69
6	12.50	1.62	8.50	8.12	12-1.00	10.62	6.72		6.75	6.63	2.25	4.06	2.25	0.50	6.75	1.81
8	15.00	1.88	10.62	10.25	12-1.12	13.00	8.72		8.75	8.63	2.69	4.62	2.69	0.50	8.75	2.00
10	17.50	2.12	12.75	12.62	16-1.25	15.25	10.88		10.92	10.75	2.88	4.88	4.00	0.50	10.88	2.19
12	20.50	2.25	15.00	14.75	16-1.38	17.75	12.88		12.92	12.75	3.12	5.38	4.25	0.50	12.94	2.38
14	23.00	2.38	16.25	16.75	20-1.38	20.25	14.14		14.18	14.00	3.31	5.88	4.62	0.50	14.19	2.50
16	25.50	2.50	18.50	19.00	20-1.50	22.50	16.16		16.19	16.00	3.69	6.00	5.00	0.50	16.19	2.69
18	28.00	2.62	21.00	21.00	24-1.50	24.75	18.18		18.20	18.00	3.88	6.50	5.38	0.50	18.19	2.75
20	30.50	2.75	23.00	23.12	24-1.62	27.00	20.20		20.25	20.00	4.00	6.62	5.75	0.50	20.19	2.88
22	33.00	2.88	25.25	25.25	24-1.75	29.25	22.22		22.25	22.00	4.25	6.75	6.00	0.50	--
24	36.00	3.00	27.25	27.62	24-1.88	32.00	24.25		24.25	24.00	4.50	6.88	6.25	0.50	24.19	3.25

Dimensions are in inches.

(a)- Bolt hole diameter 1/8 in. larger than bolt diameter.

(b)- See bore chart for wall thicknesses.

(c)- This dimension is commonly associated with "true" lap joints. Industry standard is to make to the slip on length through the hub.

ANSI B16.5 Class 600 Forged Flanges

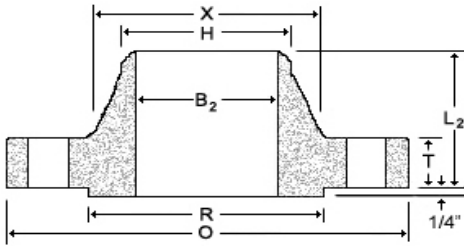

Weld Neck

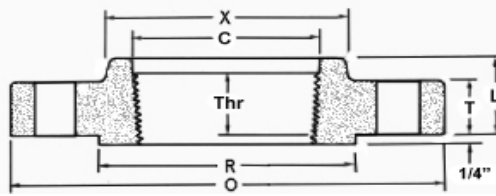

Threaded

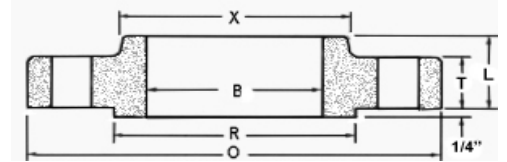

Slip-On

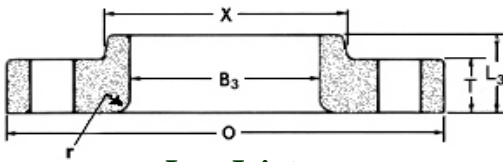

Lap Joint

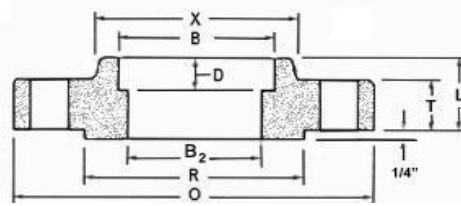

Socket Weld

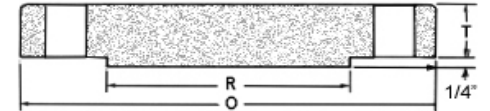

Blind

Nom. Pipe Size	O	T	R	X	#/Dia of Holes a	Bolt Circle Dia	B	B2 ^b	B3	H	L	L2	L3 ^c	r	C	D	Thr
1/2	3.75	0.56	1.38	1.50	4-0.63	2.62	0.88	To be specified by Purchaser.	0.90	0.84	0.88	2.06	0.88	0.12	0.93	0.38	0.62
3/4	4.62	0.62	1.69	1.88	4-0.75	3.25	1.09		1.11	1.05	1.00	2.25	1.00	0.12	1.14	0.44	0.62
1	4.88	0.69	2.00	2.12	4-0.75	3.50	1.36		1.38	1.32	1.06	2.44	1.06	0.12	1.41	0.50	0.69
1 1/4	5.25	0.81	2.50	2.50	4-0.75	3.88	1.70		1.72	1.66	1.12	2.62	1.12	0.19	1.75	0.56	0.81
1 1/2	6.12	0.88	2.88	2.75	4-0.88	4.50	1.95		1.97	1.90	1.25	2.75	1.25	0.25	1.99	0.62	0.88
2	6.50	1.00	3.62	3.31	8-0.75	5.00	2.44		2.46	2.38	1.44	2.88	1.44	0.31	2.50	0.69	1.12
2 1/2	7.50	1.12	4.12	3.94	8-0.88	5.88	2.94		2.97	2.88	1.62	3.12	1.62	0.31	3.00	0.75	1.25
3	8.25	1.25	5.00	4.62	8-0.88	6.62	3.57		3.60	3.50	1.81	3.25	1.81	0.38	3.63	0.81	1.38
3 1/2	9.00	1.38	5.50	5.25	8-1.00	7.25	4.07		4.10	4.00	1.94	3.38	1.94	0.38	4.13	1.56
4	10.75	1.50	6.19	6.00	8-1.00	8.50	4.57		4.60	4.50	2.12	4.00	2.12	0.44	4.63	1.62
5	13.00	1.75	7.31	7.44	8-1.12	10.50	5.66		5.69	5.56	2.38	4.50	2.38	0.44	5.69	1.88
6	14.00	1.88	8.50	8.75	12-1.12	11.50	6.72		6.75	6.63	2.62	4.62	2.62	0.50	6.75	2.00
8	16.50	2.19	10.62	10.75	12-1.25	13.75	8.72		8.75	8.63	3.00	5.25	3.00	0.50	8.75	2.25
10	20.00	2.50	12.75	13.50	16-1.38	17.00	10.88		10.92	10.75	3.38	6.00	4.38	0.50	10.88	2.56
12	22.00	2.62	15.00	15.75	20-1.38	19.25	12.88		12.92	12.75	3.62	6.12	4.62	0.50	12.94	2.75
14	23.75	2.75	16.25	17.00	20-1.50	20.75	14.14		14.18	14.00	3.69	6.50	5.00	0.50	14.19	2.88
16	27.00	3.00	18.50	19.50	20-1.63	23.75	16.16		16.19	16.00	4.19	7.00	5.50	0.50	16.19	3.06
18	29.25	3.25	21.00	21.50	20-1.75	25.75	18.18		18.20	18.00	4.62	7.25	6.00	0.50	18.19	3.12
20	32.00	3.50	23.00	24.00	24-1.75	28.50	20.20		20.25	20.00	5.00	7.50	6.50	0.50	20.19	3.25
22	34.25	3.75	25.25	26.25	24-1.88	30.63	22.22		22.25	22.00	5.25	7.75	6.88	0.50	--
24	37.00	4.00	27.25	28.25	24-2.00	33.00	24.25		24.25	24.00	5.50	8.00	7.25	0.50	24.19	3.62

Dimensions are in inches.

(a)- Bolt hole diameter 1/8 in. larger than bolt diameter.

(b)- See bore chart for wall thicknesses.

(c)- This dimension is commonly associated with "true" lap joints. Industry standard is to make to the slip on length through the hub.

ANSI B16.5 Class 900 Forged Flanges

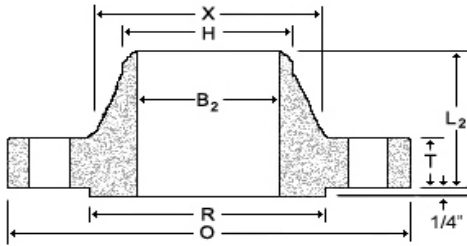

Weld Neck

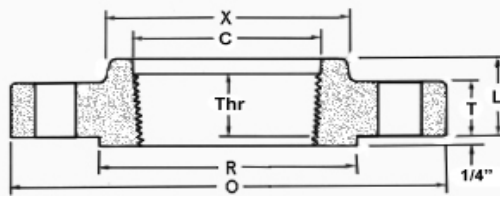

Threaded

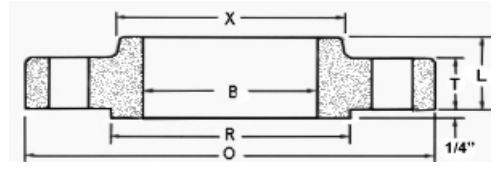

Slip-On

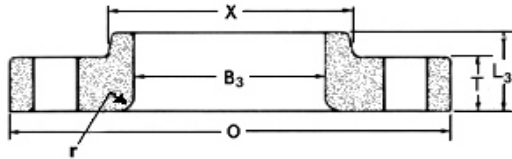

Lap Joint

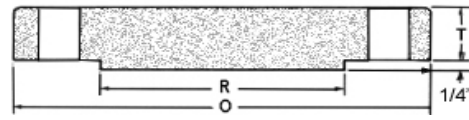

Blind

Nom. Pipe Size	O	T	R	X	#/Dia of Holes a	Bolt Circle Dia	B	B2 ^b	B3	H	L	L2	L3 ^c	r	C	Thr
Sizes 1/2" through 2 1/2" are identical to class 1500.																
3	9.50	1.50	5.00	5.00	8-1.00	7.50	3.57	To be specified by Purchaser.	3.60	3.50	2.12	4.00	2.12	0.38	3.63	1.62
4	11.50	1.75	6.19	6.25	8-1.25	9.25	4.57		4.60	4.50	2.75	4.50	2.75	0.44	4.63	1.88
5	13.75	2.00	7.31	7.50	8-1.38	11.00	5.66		5.69	5.56	3.12	5.00	3.12	0.44	5.69	2.12
6	15.00	2.19	8.50	9.25	12-1.25	12.50	6.72		6.75	6.63	3.38	5.50	3.38	0.50	6.75	2.25
8	18.50	2.50	10.63	11.75	12-1.50	15.50	8.72		8.75	8.63	4.00	6.38	4.50	0.50	8.75	2.50
10	21.50	2.75	12.75	14.50	16-1.50	18.50	10.88		10.92	10.75	4.25	7.25	5.00	0.50	10.88	2.81
12	24.00	3.12	15.00	16.50	20-1.50	21.00	12.88		12.92	12.75	4.63	7.88	5.62	0.50	12.94	3.00
14	25.25	3.38	16.25	17.75	20-1.63	22.00	14.14		14.18	14.00	5.12	8.38	6.12	0.50	14.19	3.25
16	27.75	3.50	18.50	20.00	20-1.75	24.25	16.16		16.19	16.00	5.25	8.50	6.50	0.50	16.19	3.38
18	31.00	4.00	21.00	22.25	20-2.00	27.00	18.18		18.20	18.00	6.00	9.00	7.50	0.50	18.19	3.50
20	33.75	4.25	23.00	24.50	20-2.13	29.50	20.20		20.25	20.00	6.25	9.75	8.25	0.50	20.19	3.62
24	41.00	5.50	27.25	29.50	20-2.63	35.50	24.25		24.25	24.00	8.00	11.50	10.50	0.50	24.19	4.00

Dimensions are in inches.

(a)- Bolt hole diameter 1/8 in. larger than bolt diameter.

(b)- See bore chart for wall thicknesses.

(c)- This dimension is commonly associated with "true" lap joints. Industry standard is to make to the slip on length through the hub.

ANSI B16.5 Class 1500 Forged Flanges

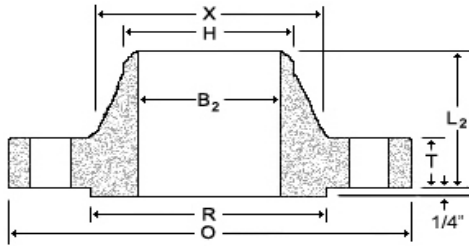

Weld Neck

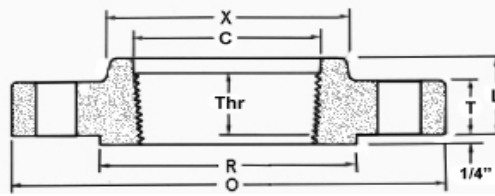

Threaded

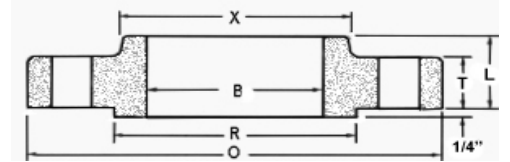

Slip-On

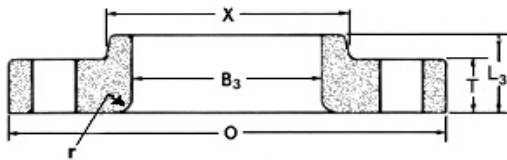

Lap Joint

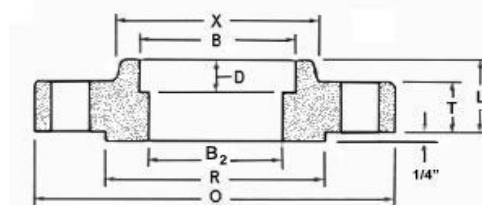

Socket Weld

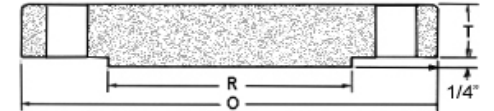

Blind

Nom. Pipe Size	O	T	R	X	#/Dia of Holes a	Bolt Circle Dia	B	B2 ^b	B3	H	L	L2	L3 ^c	r	C	D	Thr
1/2	4.75	0.88	1.38	1.50	4-0.88	3.25	0.88	To be specified by Purchaser.	0.90	0.84	1.25	2.38	1.25	0.12	0.93	0.38	0.88
3/4	5.12	1.00	1.69	1.75	4-0.88	3.50	1.09		1.11	1.05	1.38	2.75	1.38	0.12	1.14	0.44	1.00
1	5.88	1.12	2.00	2.06	4-1.00	4.00	1.36		1.38	1.32	1.62	2.88	1.62	0.12	1.41	0.50	1.12
1 1/4	6.25	1.12	2.50	2.50	4-1.00	4.38	1.70		1.72	1.66	1.62	2.88	1.62	0.19	1.75	0.56	1.19
1 1/2	7.00	1.25	2.88	2.75	4-1.12	4.88	1.95		1.97	1.90	1.75	3.25	1.75	0.25	1.99	0.62	1.25
2	8.50	1.50	3.63	4.12	8-1.00	6.50	2.44		2.46	2.38	2.25	4.00	2.25	0.31	2.50	0.69	1.50
2 1/2	9.62	1.62	4.13	4.88	8-1.12	7.50	2.94		2.97	2.88	2.50	4.12	2.50	0.31	3.00	0.75	1.88
3	10.50	1.88	5.00	5.25	8-1.25	8.00	...		3.60	3.50	...	4.62	2.88	0.38
4	12.25	2.12	6.19	6.38	8-1.38	9.50	...		4.60	4.50	...	4.88	3.56	0.44
5	14.75	2.88	7.31	7.75	8-1.63	11.50	...		5.69	5.56	...	6.12	4.12	0.44
6	15.50	3.25	8.50	9.00	12-1.50	12.50	...		6.75	6.63	...	6.75	4.69	0.50
8	19.00	3.62	10.63	11.50	12-1.75	15.50	...		8.75	8.63	...	8.38	5.62	0.50
10	23.00	4.25	12.75	14.50	12-2.00	19.00	...		10.92	10.75	...	10.00	7.00	0.50
12	26.50	4.88	15.00	17.75	16-2.12	22.50	...		12.92	12.75	...	11.12	8.62	0.50
14	29.50	5.25	16.25	19.50	16-2.38	25.00	...		14.18	14.00	...	11.75	9.50	0.50
16	32.50	5.75	18.50	21.75	16-2.63	27.75	...		16.19	16.00	...	12.25	10.25	0.50
18	36.00	6.38	21.00	23.50	16-2.88	30.50	...		18.20	18.00	...	12.88	10.88	0.50
20	38.75	7.00	23.00	25.25	16-3.12	32.75	...		20.25	20.00	...	14.00	11.50	0.50
24	46.00	8.00	27.25	30.00	16-3.63	39.00	...	24.25	24.00	...	16.00	13.00	0.50	

Dimensions are in inches.

(a)- Bolt hole diameter 1/8 in. larger than bolt diameter.

(b)- See bore chart for wall thicknesses.

(c)- This dimension is commonly associated with "true" lap joints. Industry standard is to make to the slip on length through the hub.

ANSI B16.5 Class 2500 Forged Flanges

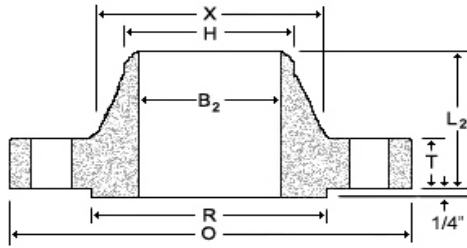

Weld Neck

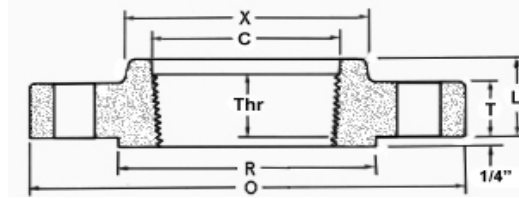

Threaded

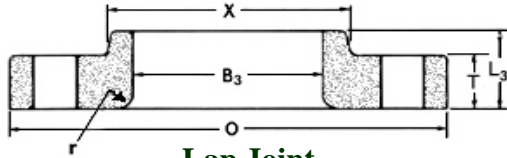

Lap Joint

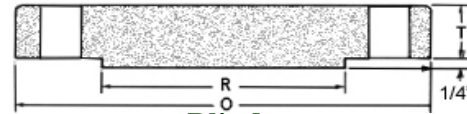

Blind

Nom. Pipe Size	O	T	R	X	#/Dia of Holes a	Bolt Circle Dia	B2 ^b	B3	H	L	L2	L3	r	C	Thr
1/2	5.25	1.19	1.38	1.69	4-0.88	3.50	To be specified by Purchaser.	0.90	0.84	1.56	2.88	1.56	0.12	0.93	1.12
3/4	5.50	1.25	1.69	2.00	4-0.88	3.75		1.11	1.05	1.69	3.12	1.69	0.12	1.14	1.25
1	6.25	1.38	2.00	2.25	4-1.00	4.25		1.38	1.32	1.88	3.50	1.88	0.12	1.41	1.38
1 1/4	7.25	1.50	2.50	2.88	4-1.12	5.13		1.72	1.66	2.06	3.75	2.06	0.19	1.75	1.50
1 1/2	8.00	1.75	2.88	3.12	4-1.25	5.75		1.97	1.90	2.38	4.38	2.38	0.25	1.99	1.75
2	9.25	2.00	3.63	3.75	8-1.12	6.75		2.46	2.38	2.75	5.00	2.75	0.31	2.50	2.00
2 1/2	10.50	2.25	4.13	4.50	8-1.25	7.75		2.97	2.88	3.12	5.62	3.12	0.31	3.00	2.25
3	12.00	2.62	5.00	5.25	8-1.38	9.00		3.60	3.50	6.62	3.62	0.38
4	14.00	3.00	6.19	6.50	8-1.63	10.75		4.60	4.50	7.50	4.25	0.44
5	16.50	3.62	7.31	8.00	8-1.88	12.75		5.69	5.56	9.00	5.12	0.44
6	19.00	4.25	8.50	9.25	8-2.12	14.50		6.75	6.63	10.75	6.00	0.50
8	21.75	5.00	10.63	12.00	12-2.12	17.25		8.75	8.63	12.50	7.00	0.50
10	26.50	6.50	12.75	14.75	12-2.63	21.25		10.92	10.75	16.50	9.00	0.50
12	30.00	7.25	15.00	17.38	12-2.88	24.38		12.92	12.75	18.25	10.00	0.50

Dimensions are in inches.

- (a)- Bolt hole diameter 1/8 in. larger than bolt diameter.
- (b)- See bore chart for wall thicknesses.

B16.47 Series A Class 150 Weld Neck & Blind

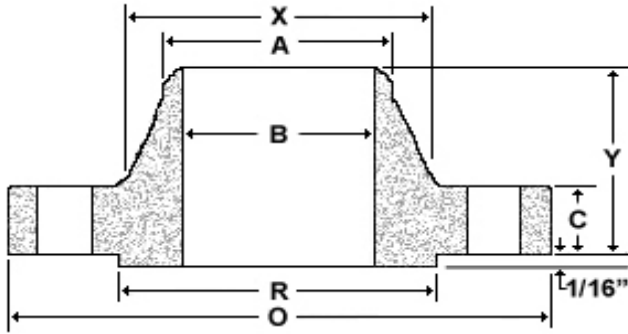

Weld Neck

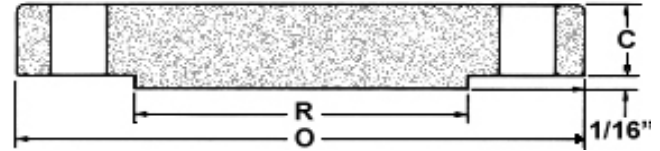

Blind

Nom Size	Thickness							Drilling				Weight		
	OD	Weld Neck	Blind	OD of RF	Dia at Base	Bore	LTH	Dia Bevel	Bolt Circle	Bolt Length	Hole Dia	# of Holes	Weld Neck	Blind
	O	C	C	R	X	B	Y	A		(1)	(2)			
26	34.25	2.63	2.63	29.50	26.62	To be specified by Purchaser.	4.69	26.00	31.75	8.75	1.38	24	300	702
28	36.50	2.75	2.75	31.50	28.62		4.88	28.00	34.00	9.00	1.38	28	345	833
30	38.75	2.88	2.88	33.75	30.75		5.32	30.00	36.00	9.25	1.38	28	400	982
32	41.75	3.13	3.13	36.00	32.75		5.63	32.00	38.50	10.50	1.62	28	505	1237
34	43.75	3.19	3.19	38.00	34.75		5.82	34.00	40.50	10.50	1.62	32	540	1384
36	46.00	3.50	3.50	40.25	36.75		6.13	36.00	42.75	11.00	1.62	32	640	1676
38	48.75	3.38	3.38	42.25	39.00		6.13	38.00	45.25	11.00	1.62	32	720	1819
40	50.75	3.50	3.50	44.25	41.00		6.38	40.00	47.25	11.00	1.62	36	775	2040
42	53.00	3.75	3.75	47.00	43.00		6.69	42.00	49.50	11.50	1.62	36	890	2381
44	55.25	3.94	3.94	49.00	45.00		6.94	44.00	51.75	12.00	1.62	40	990	2717
46	57.25	4.00	4.00	51.00	47.12		7.25	46.00	53.75	12.00	1.62	40	1060	2961
48	59.50	4.19	4.19	53.50	49.12		7.50	48.00	56.00	12.50	1.62	44	1185	3348
50	61.75	4.32	4.32	55.50	51.25		7.94	50.00	58.25	13.25	1.88	44	1270	3716
52	64.00	4.50	4.50	57.50	53.25		8.19	52.00	60.50	13.75	1.88	44	1410	4156
54	66.25	4.69	4.69	59.50	55.25		8.44	54.00	62.75	14.00	1.88	44	1585	4639
56	68.75	4.82	4.82	62.00	57.38		8.94	56.00	65.00	14.25	1.88	48	1760	5132
58	71.00	5.00	5.00	64.00	59.38		9.19	58.00	67.25	14.75	1.88	48	1915	5675
60	73.00	5.13	5.13	66.00	61.38		9.38	60.00	69.25	15.00	1.88	52	2045	6154

Dimensions are in inches. Weights are in pounds.

- (1) Bolt lengths are calculated based on bolting one WN to one Blind.
- (2) Bolt diameter should be 1/8" less than the bolt hole diameter.

Note:

Larger sizes as well as intermediate sizes can be furnished.

B16.47 Series A Class 300 Weld Neck & Blind

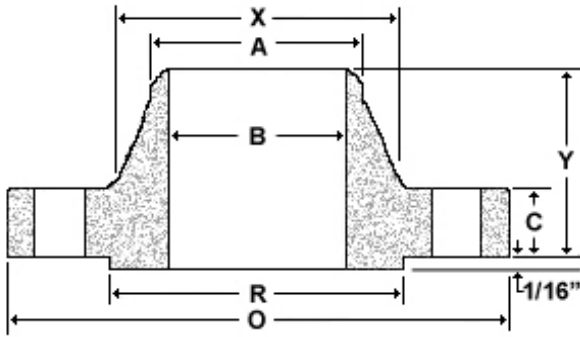

Weld Neck

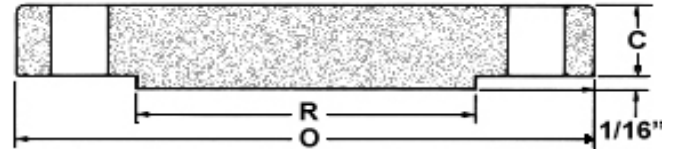

Blind

Nom Size	Thickness						Drilling						Weight	
	OD	Weld Neck	Blind	OD of RF	Dia at Base	Bore	LTH	Dia Bevel	Bolt Circle	Bolt Length	Hole Dia	# of Holes	Weld Neck	Blind
	O	C	C	R	X	B	Y	A		(1)	(2)			
26	38.25	3.07	3.25	29.50	28.38	To be specified by Purchaser.	7.19	26.00	34.50	10.75	1.75	28	605	1078
28	40.75	3.32	3.50	31.50	30.50		7.69	28.00	37.00	11.25	1.75	28	745	1315
30	43.00	3.57	3.69	33.75	32.56		8.19	30.00	39.25	12.00	1.88	28	870	1543
32	45.25	3.82	3.88	36.00	34.69		8.69	32.00	41.50	12.50	2.00	28	1100	1795
34	47.50	3.94	4.07	38.00	36.88		9.07	34.00	43.50	13.00	2.00	28	1145	2068
36	50.00	4.07	4.32	40.25	39.00		9.44	36.00	46.00	13.50	2.12	32	1275	2436
38	46.00	4.19	4.19	40.50	39.12		7.06	38.00	43.00	12.50	1.62	32	695	2001
40	48.75	4.44	4.44	42.75	41.25		7.56	40.00	45.50	13.25	1.75	32	840	2380
42	50.75	4.63	4.63	44.75	43.25		7.82	42.00	47.50	13.75	1.75	32	950	2688
44	53.25	4.82	4.82	47.00	45.25		8.06	44.00	49.75	14.25	1.88	32	1055	3079
46	55.75	5.00	5.00	49.00	47.38		8.44	46.00	52.00	15.00	2.00	28	1235	3499
48	57.75	5.19	5.19	51.25	49.38		8.75	48.00	54.00	15.25	2.00	32	1380	3896
50	60.25	5.44	5.44	53.50	51.38		9.07	50.00	56.25	16.00	2.12	32	1530	4442
52	62.25	5.63	5.63	55.50	53.38		9.32	52.00	58.25	16.50	2.12	32	1660	4906
54	65.25	5.94	5.94	57.75	55.50		9.88	54.00	61.00	17.50	2.38	28	2050	5684
56	67.25	6.00	6.00	59.75	57.62		10.19	56.00	63.00	17.75	2.38	28	2155	6098
58	69.25	6.19	6.19	62.00	59.62	10.44	58.00	65.00	18.00	2.38	32	2270	6669	
60	71.25	6.38	6.38	64.00	61.62	10.69	60.00	67.00	18.50	2.38	32	2470	7274	

Dimensions are in inches. Weights are in pounds.

- (1) Bolt lengths are calculated based on bolting one WN to one blind.
- (2) Bolt diameter should be 1/8" less than the bolt hole diameter.

Note:

Larger sizes as well as intermediate sizes can be furnished.

B16.47 Series A Class 400 Weld Neck & Blind

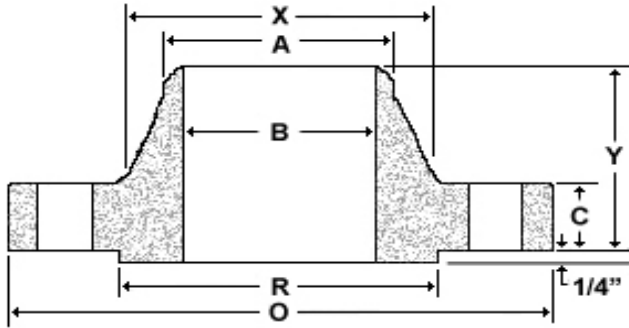

Weld Neck

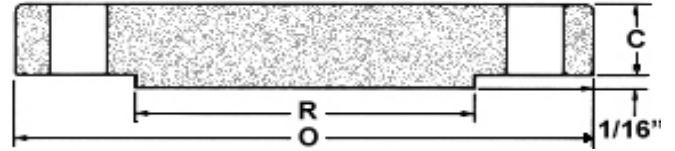

Blind

Nom Size	Thickness								Drilling				Weight	
	OD	Weld Neck	Blind	OD of RF	Dia at Base	Bore	LTH	Dia Bevel	Bolt Circle	Bolt Length	Hole Dia	# of Holes	Weld Neck	Blind
	O	C	C	R	X	B	Y	A		(1)	(2)			
26	38.25	3.50	3.88	29.50	28.62	To be specified by Purchaser.	7.62	26.00	34.50	12.50	1.88	28	650	1263
28	40.75	3.75	4.12	31.50	30.81		8.12	28.00	37.00	13.25	2.00	28	785	1522
30	43.00	4.00	4.38	33.75	32.94		8.62	30.00	39.25	14.00	2.12	28	905	1802
32	45.25	4.25	4.56	36.00	35.00		9.12	32.00	41.50	14.25	2.12	28	1065	2077
34	47.50	4.38	4.81	38.00	37.19		9.50	34.00	43.55	14.75	2.12	28	1200	2415
36	50.00	4.50	5.06	40.25	39.38		9.88	36.00	46.00	15.00	2.12	32	1340	2815
38	47.50	4.88	4.88	40.75	39.50		8.12	38.00	44.00	14.75	1.88	32	935	2450
40	50.00	5.12	5.12	43.00	41.50		8.50	40.00	46.25	15.50	2.00	32	1090	2848
42	52.00	5.25	5.25	45.00	43.62		8.81	42.00	48.25	15.75	2.00	32	1190	3159
44	54.50	5.50	5.50	47.25	45.62		9.18	44.00	50.50	16.50	2.12	32	1375	3635
46	56.75	5.75	5.75	49.50	47.75		9.62	46.00	52.75	17.00	2.12	36	1525	4120
48	59.50	6.00	6.00	51.50	49.88		10.12	48.00	55.25	18.00	2.38	28	1790	4726
50	61.75	6.19	6.25	53.62	52.00		10.56	50.00	57.50	18.50	2.38	32	1950	5303
52	63.75	6.38	6.44	55.62	54.00		10.88	52.00	59.50	18.75	2.38	32	2125	5823
54	67.00	6.69	6.75	57.88	56.12		11.38	54.00	62.25	20.00	2.62	28	2565	6742
56	69.00	6.88	6.94	60.12	58.25		11.75	56.00	64.25	20.25	2.62	32	2710	7352
58	71.00	7.00	7.12	62.12	60.25		12.06	58.00	66.25	20.50	2.62	32	3230	7986
60	74.25	7.31	7.44	64.38	62.38		12.56	60.00	69.00	21.75	2.88	32	3820	9126

Dimensions are in inches. Weights are in pounds.

- (1) Bolt lengths are calculated based on bolting one WN to one blind.
- (2) Bolt diameter should be 1/8" less than the bolt hole diameter.

Note:

Larger sizes as well as intermediate sizes can be furnished.

B16.47 Series A Class 600 Weld Neck & Blind

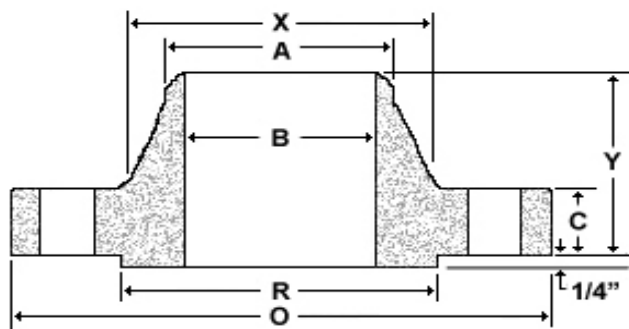

Weld Neck

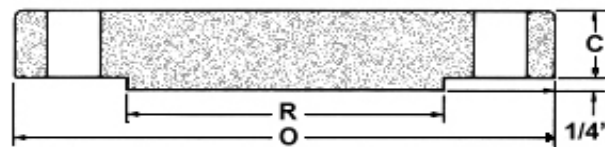

Blind

Nom Size	Thickness					Drilling							Weight	
	OD	Weld Neck	Blind	OD of RF	Dia at Base	Bore	LTH	Dia Bevel	Bolt Circle	Bolt Length	Hole Dia	# of Holes	Weld Neck	Blind
	O	C	C	R	X	B	Y	A		(1)	(2)			
26	40.00	4.25	4.94	29.50	29.44	To be specified by purchaser.	8.75	26.00	36.00	14.50	2.00	28	940	1759
28	42.25	4.38	5.19	31.50	31.62		9.25	28.00	38.00	15.00	2.12	28	1060	2061
30	44.50	4.50	5.50	33.75	33.94		9.75	30.00	40.25	15.50	2.12	28	1210	2423
32	47.00	4.62	5.81	36.00	36.12		10.25	32.00	42.50	16.50	2.38	28	1375	2856
34	49.00	4.75	6.06	38.00	38.31		10.62	34.00	44.50	16.75	2.38	28	1540	3237
36	51.75	4.88	6.38	40.25	40.62		11.12	36.00	47.00	17.75	2.62	28	1705	3802
38	50.00	6.00	6.12	41.50	40.25		10.00	38.00	45.75	18.25	2.38	28	1470	3404
40	52.00	6.25	6.38	43.75	42.25		10.38	40.00	47.75	18.75	2.38	32	1630	3838
42	55.25	6.62	6.75	46.00	44.38		11.00	42.00	50.50	19.75	2.62	28	2030	4585
44	57.25	6.81	7.00	48.25	46.50		11.38	44.00	52.50	20.25	2.62	32	2160	5105
46	59.50	7.06	7.31	50.25	48.62		11.81	46.00	54.75	20.75	2.62	32	2410	5758
48	62.75	7.44	7.69	52.50	50.75		12.44	48.00	57.50	22.25	2.88	32	2855	6737
50	65.75	7.75	8.00	54.50	52.88		12.94	50.00	60.00	23.25	3.12	28	3330	7695
52	67.75	8.00	8.25	56.50	54.88		13.25	52.00	62.00	23.75	3.12	32	3560	8426
54	70.00	8.25	8.56	58.75	57.00		13.75	54.00	64.25	24.25	3.12	32	3920	9333
56	73.00	8.56	8.88	60.75	59.12		14.25	56.00	66.75	25.50	3.38	32	4280	10529
58	75.00	8.75	9.12	63.00	61.12		14.56	58.00	68.75	26.00	3.38	32	4640	11414
60	78.50	9.19	9.56	65.25	63.38		15.31	60.00	71.75	27.25	3.62	28	5000	13108

Dimensions are in inches. Weights are in pounds.

- (1) Bolt lengths are calculated based on bolting one WN to one blind.
- (2) Bolt diameter should be 1/8" less than the bolt hole diameter.

Note:

Larger sizes as well as intermediate sizes can be furnished.

B16.47 Series A Class 900 Weld Neck & Blind

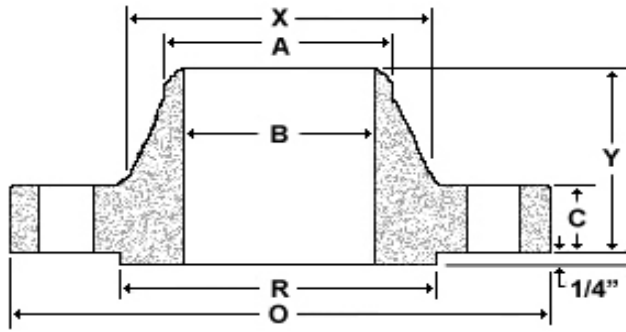

Weld Neck

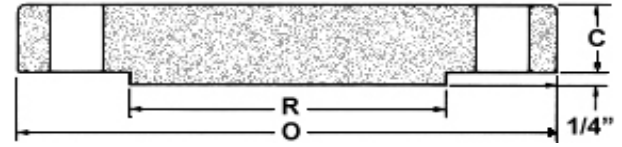

Blind

Nom Size	Thickness					Drilling							Weight	
	OD	Weld Neck	Blind	OD of RF	Dia at Base	Bore	LTH	Dia Bevel	Bolt Circle	Bolt Length	Hole Dia	# of Holes	Weld Neck	Blind
	O	C	C	R	X	B	Y	A		(1)	(2)			
26	42.75	5.50	6.31	29.50	30.50	To be specified by Purchaser.	11.25	26.00	37.50	18.75	2.88	20	1525	2566
28	46.00	5.62	6.75	31.50	32.75		11.75	28.00	40.25	19.75	3.12	20	1810	3178
30	48.50	5.88	7.18	33.75	35.00		12.25	30.00	42.75	20.50	3.12	20	2120	3758
32	51.75	6.25	7.62	36.00	37.25		13.00	32.00	45.50	22.00	3.38	20	2545	4541
34	55.00	6.50	8.06	38.00	39.2		13.75	34.00	48.25	23.00	3.62	20	2970	5425
36	57.50	6.75	8.44	40.25	41.88		14.25	36.00	50.75	23.75	3.62	20	3395	6209
38	57.50	7.50	8.50	43.25	42.25		13.88	38.00	50.75	24.50	3.62	20	3385	6253
40	59.50	7.75	8.81	45.75	44.38		14.31	40.00	52.75	25.00	3.62	24	3620	6940
42	61.50	8.12	9.12	47.75	46.31		14.62	42.00	54.75	25.75	3.62	24	3960	7675
44	64.88	8.44	9.56	50.00	48.62		15.38	44.00	57.62	27.00	3.88	24	4300	8954
46	68.25	8.88	10.06	52.50	50.88		16.18	46.00	60.50	28.50	4.12	24	4640	10426
48	70.25	9.19	10.38	54.50	52.88		16.50	48.00	62.50	29.00	4.12	24	4980	11398

Dimensions are in inches. Weights are in pounds.

- (1) Bolt lengths are calculated based on bolting one WN to one blind.
- (2) Bolt diameter should be 1/8" less than the bolt hole diameter.

Note:

Larger sizes as well as intermediate sizes can be furnished.

B16.47 Series B Class 75 Weld Neck & Blind

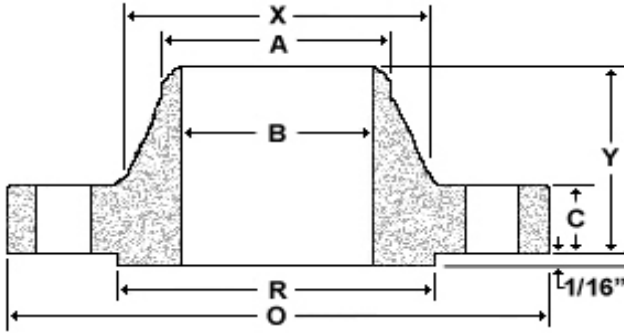

Weld Neck

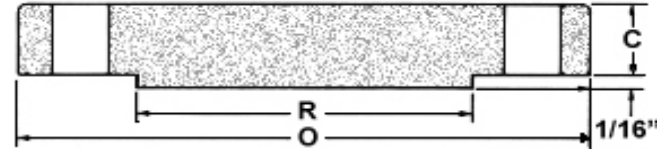

Blind

Nom Size	Thickness						Drilling				Weight			
	OD	Weld Neck	Blind	OD of RF	Dia at Base	Bore	LTH	Dia Bevel	Bolt Circle	Bolt Length	Hole Dia	# of Holes	Weld Neck	Blind
	O	C	C	R	X	B	Y	A		(1)	(2)			
26	30.00	1.25	1.25	27.75	26.62	To be specified by Purchaser.	2.25	26.06	28.50	4.50	0.75	36	80	255
28	32.00	1.25	1.25	29.75	28.62		2.38	28.06	30.50	4.50	0.75	40	85	290
30	34.00	1.25	1.25	31.75	30.62		2.50	30.06	32.50	4.50	0.75	44	90	330
32	36.00	1.32	1.38	33.75	32.62		2.69	32.06	34.50	4.75	0.75	48	105	390
34	38.00	1.30	1.44	35.75	34.62		2.82	34.06	36.50	4.75	0.75	52	110	430
36	40.69	1.38	1.61	38.00	36.81		3.32	36.06	39.06	5.25	0.88	40	145	518
38	42.69	1.44	1.69	40.00	38.81		3.44	38.06	41.06	5.50	0.88	40	160	595
40	44.69	1.44	1.69	42.00	40.81		3.57	40.06	43.06	5.50	0.88	44	170	760
42	46.69	1.50	1.82	44.00	42.81		3.69	42.06	45.06	5.50	0.88	48	185	895
44	49.25	1.63	1.88	46.25	44.88		4.07	44.06	47.38	6.00	1.00	36	230	1065
46	51.25	1.69	1.94	48.25	46.88		4.19	46.06	49.38	6.25	1.00	40	245	1185
48	53.25	1.75	2.07	50.25	48.88		4.32	48.06	51.38	6.50	1.00	44	270	1315
50	55.25	1.82	2.13	52.25	50.94		4.50	50.06	53.38	6.50	1.00	44	290	1505
52	57.38	1.82	2.19	54.25	52.94		4.69	52.06	55.50	6.75	1.00	48	310	1665
54	59.38	1.88	2.32	56.25	55.00		4.88	54.06	57.50	6.75	1.00	48	340	1840
56	62.00	1.94	2.38	58.50	57.12		5.25	56.06	59.88	7.25	1.12	40	400	2110
58	64.00	2.00	2.44	60.50	59.12	5.38	58.06	61.88	7.25	1.12	44	430	2300	
60	66.00	2.13	2.57	62.50	61.12	5.63	60.06	63.88	7.75	1.12	44	475	2500	

Dimensions are in inches. Weights are in pounds.

- (1) Bolt lengths are calculated based on bolting one WN to one blind.
- (2) Bolt diameter should be 1/8" less than the bolt hole diameter.

Note:

Larger sizes as well as intermediate sizes can be furnished.

B16.47 Series B Class 150 Weld Neck & Blind

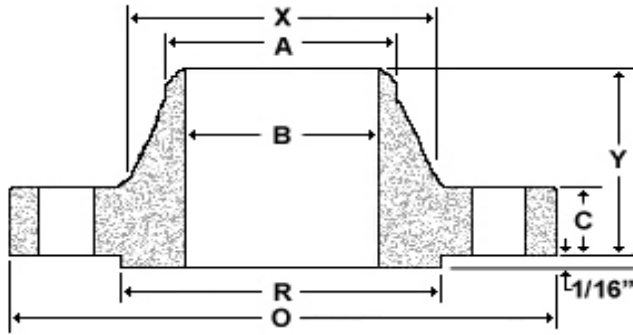

Weld Neck

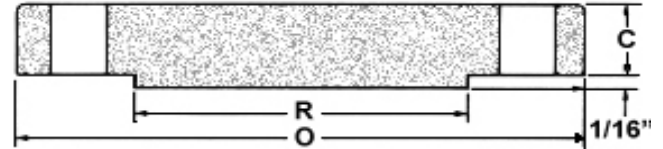

Blind

Nom Size	Thickness						Drilling				Weight			
	OD	Weld Neck	Blind	OD of RF	Dia at Base	Bore	LTH	Dia Bevel	Bolt Circle	Bolt Length	Hole Dia	# of Holes	Weld Neck	Blind
	O	C	C	R	X	B	Y	A		(1)	(2)			
26	30.94	1.57	1.69	28.00	26.94	To be specified by Purchaser.	3.44	26.06	29.31	5.50	0.88	36	120	373
28	32.94	1.69	1.82	30.00	28.94		3.69	28.06	31.31	5.75	0.88	40	140	454
30	34.94	1.69	1.94	32.00	31.00		3.88	30.06	33.31	6.00	0.88	44	150	543
32	37.06	1.75	2.07	34.00	33.06		4.19	32.06	35.44	6.25	0.88	48	170	648
34	39.56	1.88	2.19	36.25	35.12		4.28	34.06	37.69	6.75	1.00	44	210	783
36	41.62	2.00	2.25	38.25	37.19		4.57	36.06	39.75	6.75	1.00	44	240	890
38	44.25	2.07	2.44	40.25	39.25		4.82	38.12	42.12	7.50	1.12	40	290	1089
40	46.25	2.13	2.57	42.50	41.31		5.00	40.12	44.12	7.75	1.12	44	310	1247
42	48.25	2.25	2.63	44.50	43.38		5.19	42.12	46.12	7.75	1.12	48	345	1393
44	50.25	2.32	2.75	46.50	45.38		5.32	44.12	48.12	8.00	1.12	52	370	1579
46	52.81	2.38	2.88	48.62	47.44		5.63	46.12	50.56	8.50	1.25	40	435	1824
48	54.81	2.50	3.00	50.75	49.50		5.82	48.12	52.56	8.75	1.25	44	480	2045
50	56.81	2.63	3.13	52.75	51.50		6.00	50.12	54.56	9.00	1.25	48	520	2284
52	58.81	2.69	3.25	54.75	53.56		6.13	52.12	56.56	9.25	1.25	52	550	2547
54	61.00	2.75	3.38	56.75	55.62		6.32	54.12	58.75	9.50	1.25	56	620	2848
56	63.00	2.82	3.50	58.75	57.69		6.50	56.12	60.75	9.75	1.25	60	650	3144
58	65.94	2.88	3.62	60.75	59.69		6.82	58.12	63.44	10.00	1.38	48	780	3560
60	67.94	2.94	3.75	63.00	61.81		7.00	60.12	65.44	10.25	1.38	52	850	3913

Dimensions are in inches. Weights are in pounds.

- (1) Bolt lengths are calculated based on bolting one WN to one blind.
- (2) Bolt diameter should be 1/8" less than the bolt hole diameter.

Note:

Larger sizes as well as intermediate sizes can be furnished.

B16.47 Series B Class 300 Weld Neck & Blind

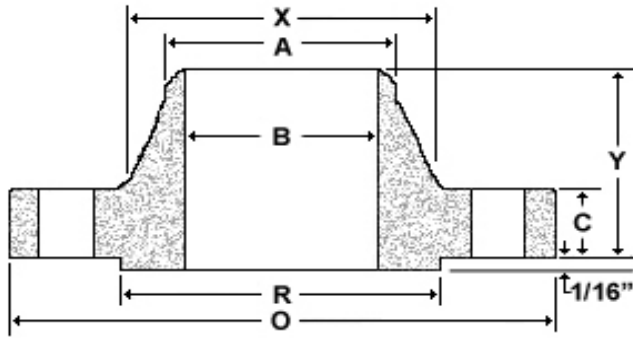

Weld Neck

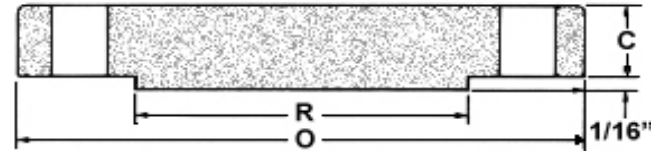

Blind

Nom Size	Thickness								Drilling				Weight	
	OD	Weld Neck	Blind	OD of RF	Dia at Base	Bore	LTH	Dia Bevel	Bolt Circle	Bolt Length	Hole Dia	# of Holes	Weld Neck	Blind
	O	C	C	R	X	B	Y	A		(1)	(2)			
26	34.12	3.44	3.44	29.00	27.62	To be specified by Purchaser.	5.63	26.19	31.62	10.50	1.38	32	400	907
28	36.25	3.44	3.44	31.00	29.75		5.81	28.19	33.75	10.50	1.38	36	450	1023
30	39.00	3.63	3.63	33.25	32.00		6.16	30.25	36.25	11.25	1.50	36	550	1249
32	41.50	4.00	4.00	35.50	34.00		6.56	32.25	38.50	12.00	1.62	32	685	1556
34	43.62	4.00	4.00	37.50	36.12		6.75	34.25	40.62	12.00	1.62	36	750	1719
36	46.12	4.00	4.00	39.75	38.00		7.06	36.25	42.88	12.50	1.75	32	840	1921
38	48.12	4.31	4.31	41.75	40.00		7.50	38.25	44.88	13.00	1.75	36	915	2257
40	50.12	4.50	4.50	43.88	42.00		7.75	40.25	46.88	13.50	1.75	40	990	2549
42	52.50	4.63	4.63	46.00	44.00		8.00	42.31	49.00	14.00	1.88	36	1135	2876
44	54.50	4.94	4.94	48.00	46.19		8.38	44.31	51.00	14.50	1.88	40	1235	3304
46	57.50	5.00	5.06	50.00	48.38		8.69	46.31	53.75	15.00	2.00	36	1470	3766
48	59.50	5.00	5.25	52.25	50.31		8.75	48.31	55.75	15.25	2.00	40	1575	4183
50	61.50	5.38	5.44	54.25	52.38		9.19	50.31	57.75	15.75	2.00	44	1710	4629
52	63.50	5.56	5.61	56.25	54.44		9.50	52.31	59.75	16.00	2.00	48	1840	5096
54	65.88	5.32	5.81	58.25	56.50		9.38	54.31	62.12	16.00	2.00	48	1980	5678
56	69.50	6.00	6.12	60.50	58.81		10.50	56.31	65.00	17.75	2.38	36	2595	6642
58	71.94	6.00	6.31	62.75	60.94		10.75	58.31	67.44	18.00	2.38	40	2770	7347
60	73.94	5.88	6.50	65.00	62.94		10.63	60.31	69.44	18.00	2.38	40	2870	7980

Dimensions are in inches. Weights are in pounds.

- (1) Bolt lengths are calculated based on bolting one WN to one blind.
- (2) Bolt diameter should be 1/8" less than the bolt hole diameter.

Note:

Larger sizes as well as intermediate sizes can be furnished.

B16.47 Series B Class 400 Weld Neck & Blind

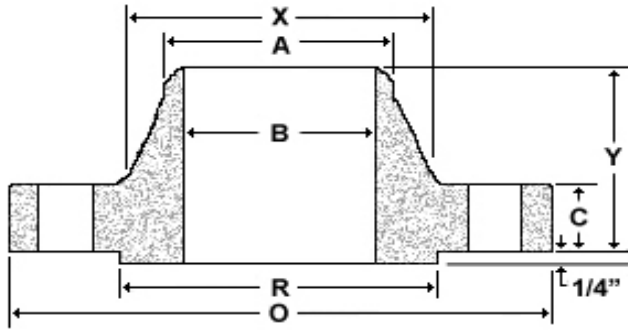

Weld Neck

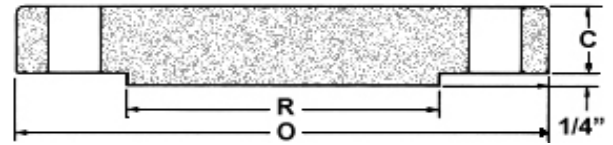

Blind

Nom Size	Thickness			OD of RF R	Dia at Base X	Bore B	LTH Y	Dia Bevel A	Drilling			Weights		
	OD	Weld Neck	Blind						Bolt Circle	Bolt Length	Hole Dia	# of Holes	Weld Neck	Blind
	O	C	C							(1)	(2)			
26	33.5	3.5	3.5	28	27.12	To be specified by Purchaser.	5.88	26	30.75	11.25	1.5	28	360	874
28	36	3.75	3.75	30	29.12		6.25	28	33	12	1.62	24	450	1081
30	38.36	4	4	32.25	31.25		6.69	30	35.25	12.5	1.62	28	530	1302
32	40.75	4.25	4.25	34.38	33.25		7.06	32	38.5	13.25	1.75	28	635	1570
34	42.75	4.38	4.38	36.5	35.38		7.38	34	39.5	13.5	1.75	32	690	1781
36	45.5	4.69	4.69	38.62	37.5		7.88	36	42	14.5	1.88	28	855	2160
38	47.5	4.88	4.88	40.75	39.5		8.12	38	44	14.75	1.88	32	935	2450
40	50	5.12	5.12	43	41.5		8.5	40	46.25	15.5	2	32	1090	2848
42	52	5.25	5.25	45	43.62		8.81	42	48.25	15.75	2	32	1190	3159
44	54.5	5.5	5.5	47.25	45.62		9.18	44	50.50	16.5	2.12	32	1375	3635
46	56.75	5.75	5.75	49.5	47.75		9.62	46	52.75	17	2.12	36	1525	4120
48	59.5	6	6	51.5	49.88		10.12	48	55.25	18	2.38	28	1790	4726
50	61.75	6.19	6.25	53.62	52		10.56	50	57.5	18.5	2.38	32	1950	5303
52	63.75	6.38	6.44	55.62	54		10.88	52	59.5	18.75	2.38	32	2125	5823
54	67	6.69	6.75	57.88	56.12		11.38	54	62.25	20	2.62	28	2565	6742
56	69	6.88	6.94	60.12	58.25		11.75	56	64.25	20.25	2.62	32	2710	7352
58	71	7	7.12	62.12	60.25		12.06	58	66.25	20.5	2.62	32	3230	7986
60	74.25	7.31	7.44	64.38	62.38		12.56	60	69	21.75	2.88	32	3820	9126

Dimensions are in inches. Weights are in pounds.

- (1) Bolt lengths are calculated based on bolting one WN to one blind.
- (2) Bolt diameter should be 1/8" less than the bolt hole diameter.

Note:
 Larger sizes as well as intermediate sizes can be furnished.

B16.47 Series B Class 600 Weld Neck & Blind

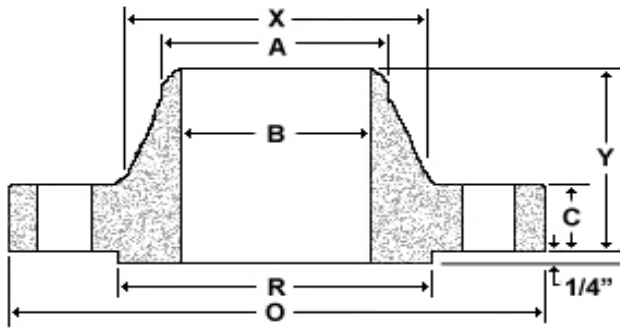

Weld Neck

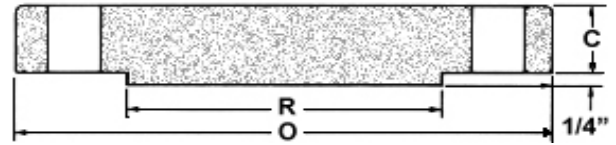

Blind

Nom Size	Thickness		OD of RF R	Dia at Base X	Bore B	LTH Y	Dia Bevel A	Drilling			Weights			
	OD	Weld Neck						Blind	Bolt Circle	Bolt Length	Hole Dia	# of Holes	Weld Neck	Blind
	O	C						C		(1)	(2)			
26	35.00	4.38	4.38	28.62	27.50	7.12	26.00	31.75	13.50	1.75	28	550	1194	
28	37.50	4.56	4.56	30.88	29.62	7.50	28.00	34.00	14.25	1.88	28	650	1427	
30	40.25	4.94	5.00	33.12	31.75	8.06	30.00	36.50	15.25	2.00	28	810	1802	
32	42.75	5.12	5.31	35.25	33.88	8.50	32.00	38.75	16.00	2.12	28	950	2159	
34	45.25	5.30	5.59	37.50	36.00	8.99	34.00	41.00	17.25	2.28	24	1205	2645	
36	47.75	5.75	5.94	39.75	38.12	9.56	36.00	43.50	17.75	2.38	28	1340	3013	
38	50.00	6.00	6.12	41.50	40.25	10.00	38.00	45.75	18.25	2.38	28	1470	3404	
40	52.00	6.25	6.38	43.75	42.25	10.38	40.00	47.75	18.75	2.38	32	1630	3838	
42	55.25	6.62	6.75	46.00	44.38	11.00	42.00	50.50	19.75	2.62	28	2030	4585	
44	57.25	6.81	7.00	48.25	46.50	11.38	44.00	52.50	20.25	2.62	32	2160	5105	
46	59.50	7.06	7.31	50.25	48.62	11.81	46.00	54.75	20.75	2.62	32	2410	5758	
48	62.75	7.44	7.69	52.50	50.75	12.44	48.00	57.50	22.25	2.88	32	2855	6737	
50	65.75	7.75	8.00	54.50	52.88	12.94	50.00	60.00	23.25	3.12	28	3330	7695	
52	67.75	8.00	8.25	56.50	54.88	13.25	52.00	62.00	23.75	3.12	32	3560	8426	
54	70.00	8.25	8.56	58.75	57.00	13.75	54.00	64.25	24.25	3.12	32	3920	9333	
56	73.00	8.56	8.88	60.75	59.12	14.25	56.00	66.75	25.50	3.38	32	4280	10,529	
58	75.00	8.75	9.12	63.00	61.12	14.56	58.00	68.75	26.00	3.38	32	4640	11,414	
60	78.50	9.19	9.30	65.25	63.38	15.31	60.00	71.75	27.25	3.02	28	5000	13,108	

To be specified by Purchaser.

Dimensions are in inches. Weights are in pounds.

- (1) Bolt lengths are calculated based on bolting one WN to one blind.
- (2) Bolt diameter should be 1/8" less than the bolt hole diameter.

Note:
Larger sizes as well as intermediate sizes can be furnished.

B16.47 Series B Class 900 Weld Neck & Blind

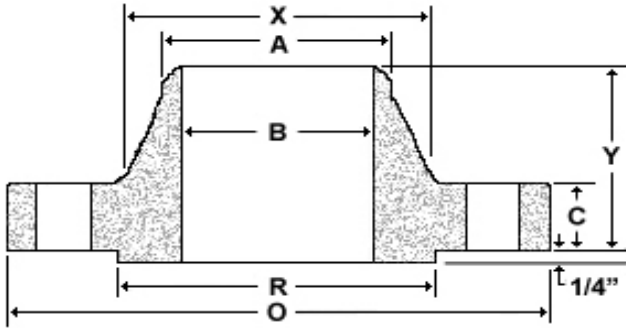

Weld Neck

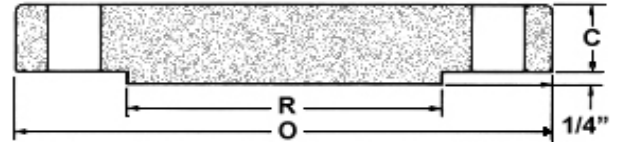

Blind

Nom Size	Thickness		OD of RF R	Dia at Base X	Bore B	Drilling						Weights	
	OD	Blind				LTH	Dia Bevel	Bolt Circle	Bolt Length	Hole Dia	# of Holes	Weld Neck	Blind
	O	C				Y	A		(1)	(2)			
26	40.25	5.31	30.00	29.25	To be specified by Purchaser.	10.19	26.00	35.50	17.75	2.62	20	1050	2184
28	43.50	5.81	32.25	31.38		10.88	28.00	38.25	19.50	2.88	20	1520	2762
30	46.50	6.12	34.50	33.50		11.38	30.00	40.75	20.50	3.12	20	1820	3334
32	48.75	6.31	36.50	35.75		11.94	32.00	43.00	21.00	3.12	20	2065	3865
34	51.75	6.75	39.00	37.88		12.56	34.00	45.50	22.50	3.12	20	2450	4576
36	53.00	6.81	40.50	40.00		12.81	36.00	47.25	22.25	3.12	24	2520	4963
38	57.50	7.50	43.25	42.25		13.88	38.00	50.75	24.50	3.62	20	3385	6253
40	59.50	7.75	45.75	44.38		14.31	40.00	52.75	25.00	3.62	24	3620	6940
42	61.50	8.12	47.75	46.31		14.62	42.00	54.75	25.75	3.62	24	3960	7675
44	64.88	8.44	50.00	48.62		15.38	44.00	57.62	27.00	3.88	24	4300	8954
46	68.25	8.88	52.50	50.88		16.18	46.00	60.50	28.50	4.12	24	4640	10,426
48	70.25	9.19	54.50	52.88		16.50	48.00	62.50	29.00	4.12	24	4980	11,398

Dimensions are in inches. Weights are in pounds.

- (1) Bolt lengths are calculated based on bolting one WN to one blind.
- (2) Bolt diameter should be 1/8" less than the bolt hole diameter.

Note:
 Larger sizes as well as intermediate sizes can be furnished.

Brew Quality Flanges

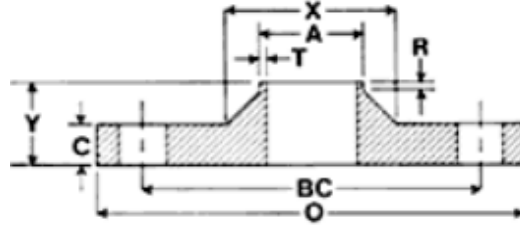

NOMINAL PIPE SIZES	O	C	Y	A	X	T	R	BC	DIA HOLES	QTY HOLES
1/2"	3.50	.38	.88	.84	1.19	.065	.25	2.38	.62	4.00
3/4"	3.88	.38	.88	1.05	1.50	.065	.25	2.75	.62	4.00
1"	4.25	.38	.88	1.32	1.94	.065	.25	3.12	.62	4.00
1 1/4"	4.62	.38	.88	1.66	2.31	.065	.25	3.50	.62	4.00
1 1/2"	5.00	.38	.88	1.90	2.56	.065	.25	3.88	.62	4.00
2"	6.00	.44	1.00	2.38	3.06	.065	.25	4.75	.75	4.00
2 1/2"	7.00	.44	1.00	2.88	3.56	.083	.31	5.50	.75	4.00
3"	7.50	.5	1.12	3.50	4.25	.083	.31	6.00	.75	4.00
4"	9.00	.5	1.12	4.50	5.31	.083	.31	7.50	.75	8.00
5"	10.00	.5	1.12	5.56	6.44	.109	.31	8.50	.88	8.00
6"	11.00	.56	1.25	6.62	7.56	.109	.31	9.50	.88	8.00
8"	13.50	.56	1.25	8.62	9.69	.109	.31	11.75	.88	8.00
10"	16.00	.69	1.38	10.75	12.00	.134	.38	14.25	1.00	12.00
12"	19.00	.69	1.38	12.75	14.38	.156	.38	17.00	1.00	12.00

Bolt and Stud Dimensions ASME B16.5

Nominal Pipe Size	150 LB. Flanges				300 LB. Flanges				600 LB. Flanges			
	# Bolts or Studs	Dia of Bolts or Studs	Length of Stud		# Bolts or Studs	Dia of Bolts or Studs	Length of Stud		# Bolts or Studs	Dia of Bolts or Studs	Length of Stud	
			1/16 RF	RTJ			1/16 RF	RTJ			1/4 RF	RTJ
1/2	4	0.50	2-1/4	-	4	0.50	2-1/2	3	4	0.50	3	3
3/4	4	0.50	2-1/2	-	4	0.63	3	3-1/2	4	0.63	3-1/2	3-1/2
1	4	0.50	2-1/2	3	4	0.63	3	3-1/2	4	0.63	3-1/2	3-1/2
1-1/4	4	0.50	2-3/4	3-1/4	4	0.63	3-1/4	3-3/4	4	0.63	3-3/4	3-3/4
1-1/2	4	0.50	2-3/4	3-1/4	4	0.75	3-1/2	4	4	0.75	4-1/4	4-1/4
2	4	0.63	3-1/4	3-3/4	8	0.63	3-1/2	4	8	0.63	4-1/4	4-1/4
2-1/2	4	0.63	3-1/2	4	8	0.75	4	4-1/2	8	0.75	4-3/4	4-3/4
3	4	0.63	3-1/2	4	8	0.75	4-1/4	4-3/4	8	0.75	5	5
3-1/2	8	0.63	3-1/2	4	8	0.75	4-1/4	5	8	0.88	5-1/2	5-1/2
4	8	0.63	3-1/2	4	8	0.75	4-1/2	5	8	0.88	5-3/4	5-3/4
5	8	0.75	3-3/4	4-1/4	8	0.75	4-3/4	5-1/4	8	1.00	6-1/2	6-1/2
6	8	0.75	4	4-1/2	12	0.75	4-3/4	5-1/2	12	1.00	6-3/4	6-3/4
8	8	0.75	4-1/4	4-3/4	12	0.88	5-1/2	6	12	1.13	7-1/2	7-3/4
10	12	0.88	4-1/2	5	16	1.00	6-1/4	6-3/4	16	1.25	8-1/2	8-1/2
12	12	0.88	4-3/4	5-1/4	16	1.13	6-3/4	7-1/4	20	1.25	8-3/4	8-3/4
14	12	1.00	5-1/4	5-3/4	20	1.13	7	7-1/2	20	1.38	9-1/4	9-1/4
16	16	1.00	5-1/4	5-3/4	20	1.25	7-1/2	8	20	1.50	10	10
18	16	1.13	5-3/4	6-1/4	24	1.25	7-3/4	8-1/4	20	1.63	10-3/4	10-3/4
20	20	1.13	6-1/4	6-3/4	24	1.25	8	8-3/4	24	1.63	11-1/4	11-1/2
24	20	1.25	6-3/4	7-1/4	24	1.50	9	10	24	1.88	13	13-1/4

Nominal Pipe Size	900 LB. Flanges				1500 LB. Flanges				2500 LB. Flanges			
	# Bolts or Studs	Dia of Bolts or Studs	Length of Stud		# Bolts or Studs	Dia of Bolts or Studs	Length of Stud		# Bolts or Studs	Dia of Bolts or Studs	Length of Stud	
			1/4 RF	RTJ			1/4 RF	RTJ			1/4 RF	RTJ
1/2	4	0.75	4-1/4	4-1/4	4	0.75	4-1/4	4-1/4	4	0.75	4-3/4	4-3/4
3/4	4	0.75	4-1/2	4-1/2	4	0.75	4-1/2	4-1/2	4	0.75	5	5
1	4	0.88	5	5	4	0.88	5	5	4	0.88	5-1/2	5-1/2
1-1/4	4	0.88	5	5	4	0.88	5	5	4	1.00	6	6
1-1/2	4	1.00	5-1/2	5-1/2	4	1.00	5-1/2	5-1/2	4	1.13	6-3/4	6-3/4
2	8	0.88	5-3/4	5-3/4	8	0.88	5-3/4	5-3/4	8	1.00	7	7
2-1/2	8	1.00	6-1/4	6-1/4	8	1.00	6-1/4	6-1/4	8	1.13	7-3/4	8
3	8	0.88	5-3/4	5-3/4	8	1.13	7	7	8	1.25	8-3/4	9
4	8	1.13	6-3/4	6-3/4	8	1.25	7-3/4	7-3/4	8	1.50	10	10-1/4
5	8	1.25	7-1/2	7-1/2	8	1.50	9-3/4	9-3/4	8	1.75	11-3/4	12-1/4
6	12	1.13	7-1/2	7-3/4	12	1.38	10-1/4	10-1/2	8	2.00	13-1/2	14
8	12	1.38	8-3/4	8-3/4	12	1.63	11-1/2	12-3/4	12	2.00	15	15-1/2
10	16	1.38	9-1/4	9-1/4	12	1.88	13-1/4	13-1/2	12	2.50	19-1/4	20
12	20	1.38	10	10	16	2.00	14-3/4	15-1/4	12	2.75	21-1/4	22
14	20	1.50	10-3/4	11	16	2.25	16	16-3/4	-	-	-	-
16	20	1.63	11-1/4	11-1/2	16	2.50	17-1/2	18-1/2	-	-	-	-
18	20	1.88	12-3/4	13-1/4	16	2.75	19-1/2	20-3/4	-	-	-	-
20	20	2.00	13-3/4	14-1/4	16	3.00	21-1/4	22-1/4	-	-	-	-
24	20	2.50	17-1/4	18	16	3.50	24-1/4	25-1/2	-	-	-	-

Dimensions are in inches.

Class 125LW (175-150 psi*) Same as AWWA Class D Hub

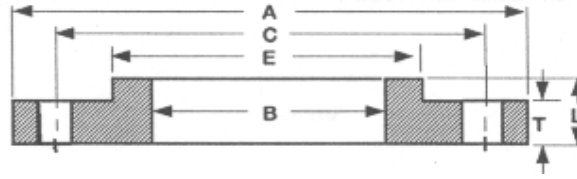

Nom Size						Drilling				Weight
	OD	Thickness	Dia at Base	Bore	LTH	Bolt Circle	Bolt Length	Hole Dia	# of Holes	
	A	T	E	B	L	C				
4	9	0.5	5.312	4.57	0.875	7.5	2.75	0.75	8	7
5	10	0.562	6.438	5.66	1.25	8.5	3.25	0.875	8	9
6	11	0.562	7.562	6.72	1.25	9.5	3.25	0.875	8	11
8	13.5	0.562	9.688	8.72	1.25	11.75	3.25	0.875	8	15
10	16	0.688	12	10.88	1.25	14.25	3.75	1	12	22
12	19	0.688	14.375	12.88	1.25	17	3.75	1	12	33
14	21	0.75	15.75	14.19	1.25	18.75	4	1.125	12	43
16	23.5	0.75	18	16.19	1.25	21.25	4	1.125	16	52
18	25	0.75	19.875	18.19	1.25	22.75	4.25	1.25	16	52
20	27.5	0.75	22	20.19	1.25	25	4.25	1.25	20	61
22	29.5	1	24	22.19	1.75	27.25	5	1.375	20	92
24	32	1	26.25	24.19	1.755	29.53	5	1.375	20	105
26	34.25	1	28.5	26.19	1.75	31.75	5	1.375	24	119
28	36.5	1	30.5	28.19	1.75	34	5	1.375	28	130
30	38.75	1	32.5	30.19	1.75	36	5	1.375	28	144
32	41.75	1.125	34.75	32.19	1.75	38.5	6	1.625	28	182
34	43.75	1.125	36.75	34.19	1.75	40.5	6	1.625	32	191
36	46	1.125	38.75	36.19	1.75	42.75	6	1.625	32	207
38	48.75	1.125	40.75	38.19	1.75	45.25	6	1.625	32	237
40	50.75	1.125	43	40.19	1.75	47.25	6	1.625	36	249
42	53	1.25	45	42.19	1.75	49.5	6.25	1.625	36	287
44	55.25	1.25	47	44.19	2.25	51.75	6.25	1.625	40	334
46	57.25	1.25	49	46.19	2.25	53.75	6.25	1.625	40	348
48	59.5	1.375	51	48.19	2.5	56	6.5	1.625	44	407
50	61.75	1.375	53	50.19	2.5	58.25	7	1.875	44	421
52	64	1.375	55	52.19	2.5	60.5	7	1.875	44	448
54	66.25	1.375	57	54.19	2.5	62.75	7	1.875	44	475
60	73	1.5	63	60.19	2.75	69.25	7.25	1.875	52	605
66	80	1.5	69	66.19	2.75	76	7.25	1.875	52	718
72	86.5	1.5	75	72.19	2.75	82.5	7.25	1.875	60	803
78	93	1.75	81.25	78.19	3	89	8.25	2.125	64	1010
84	99.75	1.75	87.5	84.19	3	95.5	8.25	2.125	64	1160
90	106.5	2	93.75	90.19	3.25	102	9.5	2.438	68	1430
96	113.25	2	100	96.19	3.25	108.5	9.5	2.438	68	1618

Dimensions are in inches. Weights are in pounds.

Notes: Hub flanges are to be used on pipe that has an OD equal to the nominal pipe size in the first column. *Pressure Ratings are from AWWA Table 3 Class D. Pressure rating at atmospheric temperature: sizes 4-12 in. inclusive, 175 psi; sizes larger than 12 in., 150 psi. These flanges have the same diameter and drilling as ANSI/ASME B16.1 class 125 cast-iron flanges. In sizes 24in. and smaller they also match up to ANSI/ASME B16.5 150-psi standard for steel flanges

Class 125 SO (275 psi*) Same as AWWA Table 4 Class E

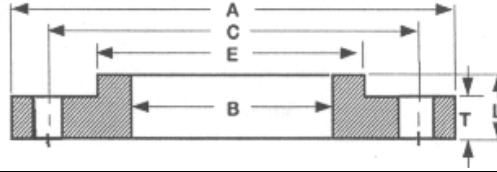

Nom Size						Drilling				Weight
	OD	Thickness	Dia at Base	Bore	LTH	Bolt Circle	Bolt Length	Hole Dia	# of Holes	
	A	T	E	B	L	C				
4	9.00	0.938	5.312	4.57	1.312	7.50	3.75	0.750	8	13
5	10.00	0.938	6.438	5.66	1.438	8.50	4.00	0.875	8	14
6	1.000	1.000	7.562	6.72	1.562	9.50	4.00	0.875	8	17
8	13.50	1.125	9.688	8.72	1.750	11.75	4.50	0.875	8	28
10	16.00	1.188	12.000	10.88	1.938	14.25	5.00	1.000	12	37
12	19.00	1.250	14.375	12.88	2.188	17.00	5.00	1.000	12	59
14	21.00	1.375	15.750	14.19	2.250	18.75	5.50	1.125	12	78
16	23.50	1.438	18.000	16.19	2.500	21.25	5.75	1.125	16	101
18	25.00	1.562	19.875	18.19	2.688	22.75	6.00	1.250	16	110
20	27.50	1.688	22.000	20.19	2.875	25.00	6.50	1.250	20	139
22	29.50	1.812	24.000	22.19	3.125	27.25	6.75	1.375	20	162
24	32.00	1.875	26.125	24.19	3.250	29.50	7.00	1.375	20	197
26	34.25	2.00	26.30	26.19	3.375	31.75	7.25	1.375	24	200
28	36.50	2.062	30.750	28.19	3.438	34.00	7.50	1.375	28	269
30	38.75	2.125	32.750	30.19	3.500	36.00	7.75	1.375	28	303
32	41.75	2.250	35.000	32.195	3.62	38.50	8.50	1.625	28	375
34	43.75	2.312	37.000	34.19	3.688	40.50	8.50	1.625	28	401
36	46.00	2.375	39.250	36.19	3.750	42.75	8.75	1.625	32	452
38	48.75	2.375	41.750	38.19	3.750	45.25	8.75	1.625	32	528
40	50.75	2.500	43.750	40.19	3.875	47.25	9.00	1.625	36	573
42	53.00	2.625	46.000	42.19	4.000	49.50	9.25	1.625	36	648
44	55.25	2.625	48.000	44.19	4.000	51.75	9.25	1.625	40	688
46	57.25	2.688	50.000	46.19	4.062	53.75	9.25	1.625	40	733
48	59.50	2.750	52.250	48.19	4.125	56.00	9.50	1.625	44	799
50	61.75	2.750	54.250	50.19	4.125	58.25	10.00	1.875	44	827
52	64.00	2.875	56.500	52.19	4.250	60.50	10.25	1.875	44	922
54	66.25	3.000	58.750	54.19	4.375	62.75	10.50	1.875	44	1024
60	73.00	3.125	65.250	60.19	4.500	69.25	11.00	1.875	52	1253
66	80.00	3.375	71.500	66.19	4.875	76.00	11.50	1.875	52	1623
72	86.50	3.500	78.500	72.19	5.000	82.50	11.75	1.875	60	1922
78	93.00	3.875	84.500	78.19	5.375	89.00	11.75	1.875	60	2279
84	99.75	3.875	90.500	84.19	5.375	95.50	13.00	2.125	64	2586
90	106.50	4.250	96.750	90.19	5.750	102.00	14.25	2.438	68	3061
96	113.25	4.250	102.750	96.19	5.750	108.50	14.25	2.438	68	3432

Dimensions are in inches. Weights are in pounds.

Notes: Commonly referred to as a class 150# in larger diameter. Can be furnished with a raised face. *Pressure ratings from AWWA table 4 Class E. Pressure rating at atmospheric temperature is 275 psi. These flanges have the same OD and drilling as ANSI/ASME B16.1 class 125 cast-iron flanges. In sizes 24 in. and smaller, they also match ANSI/ASME B16.5 150-psi standard for steel flanges

Class 125 WN

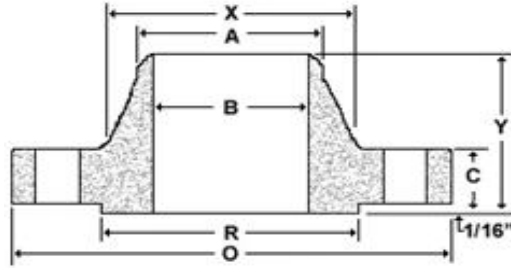

Nom Size	OD	Thickness	OD of RF	Dia at Base	Bore	Dia Bevel	LTH	Drilling				Weight
								Bolt Circle	Bolt Length	Hole Dia	# of Holes	
	O	C	R	X	B	A	Y					
6	11	1	8.5	7.56	To be specified by Purchaser.	6.63	3.5	9.5	4	0.88	8	24
8	13.5	1.13	10.63	9.69		8.63	4	11.75	4.5	0.88	8	39
10	16	1.19	12.75	12		10.75	4	14.25	5	1	12	52
12	19	1.25	15	14.38		12.75	4.5	17	5	1	12	80
14	21	1.38	16.25	15.75		14	5	18.75	5.5	1.13	12	110
16	23.5	1.44	18.5	18		16	5	21.25	5.75	1.13	16	140
18	25	1.56	21	19.88		18	5.5	22.75	6	1.25	16	150
20	27.5	1.69	23	22		20	5.69	25	6.5	1.25	20	180
22	29.5		25.25	24.25		22		27.25			20	225
24	32	1.88	27.25	26.13		24	6	29.5	7	1.38	20	255
26	34.25	2	29.5	28.5		26	5	31.75	7.25	1.38	24	265
28	36.5	2.06	31.5	30.75		28	5.06	34	7.5	1.38	28	295
30	38.75	2.13	33.75	32.75		30	5.13	36	7.75	1.38	28	340
32	41.75	2.25	36	35		32	5.25	38.5	8.5	1.63	28	410
34	43.75	2.31	38	37		34	5.31	40.5	8.5	1.63	32	440
36	46	2.38	40.25	39.25		36	5.38	42.75	8.75	1.63	32	495
38	48.75	2.38	42.25	41.75		38	5.38	45.25	8.75	1.63	32	570
40	50.75	2.5	44.25	43.75		40	5.5	47.25	9	1.63	36	620
42	53	2.63	47	46		42	5.63	49.5	9.25	1.63	36	710
44	55.25	2.63	49	48		44	5.63	51.75	9.25	1.63	40	750
46	57.25	2.69	51	50		46	5.68	53.75	9.25	1.63	40	800
48	59.5	2.75	53.5	52.25		48	5.75	56	9.5	1.63	44	870
50	61.75	2.75	55.5	54.25		50	5.75	58.25	10	1.88	44	900
52	64	2.88	57.5	56.5		52	5.88	60.5	10.25	1.88	44	1000
54	66.25	3	59.75	58.75	54	6	62.75	10.5	1.88	44	1100	
60	73	3.13	66	65.25	60	6.13	69.25	11	1.88	52	1350	
66	80	3.38	-	71.5	66	6.38	76	11.5	1.88	52	1775	
72	86.5	3.5	-	78.5	72	6.5	82.5	11.75	1.88	60	2100	
84	99.75	3.88	-	90.5	84	6.88	95.5	13	2.13	64	2825	
96	113.25	4.25	-	102.75	96	7.25	108.5	14.25	2.44	68	3800	

Dimensions are in inches. Weights are in pounds.

Notes: Can be furnished with a flat face. These flanges have the same OD and drilling as ANSI/ASME B16.1 class 125 cast-iron flanges.

Class 250 (300 psi*)

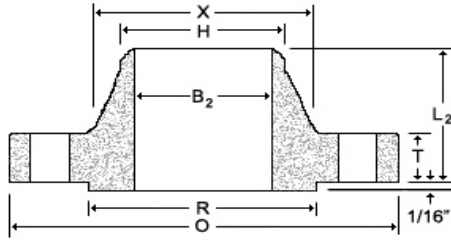

Weld Neck

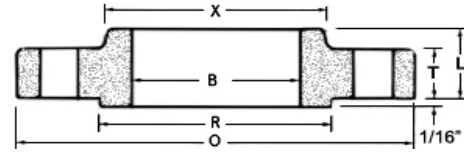

Slip-On

Nom. Size					Bore		LTH		Drilling				Weights		
	OD	Thickness	OD of RF	Dia at Base	WN	SO	Weld Neck	SO	Bolt Circle	Bolt Length	Hole Dia	# of Holes	Weld Neck	Slip-on	Blind
	O	T	R	X	B2	B	L2	L							
26	38.25	2.81	32.44	30.50	To be specified by Purchaser.	26.25	5.81	4.75	34.50	10.00	1.88	28	534	531	916
28	40.75	2.94	34.94	33.00		28.25	5.94	5.00	37.00	10.25	1.88	28	629	637	1095
30	43.00	3.00	37.19	35.25		30.25	6.00	5.00	39.25	10.50	1.88	28	702	707	1236
32	45.25	3.12	39.44	37.50		32.25	6.12	5.12	41.50	10.75	1.88	28	793	801	1424
34	47.50	3.25	41.44	39.50		34.25	6.25	5.25	43.50	11.25	1.88	28	882	889	1649
36	50.00	3.38	43.69	41.50		36.25	6.38	5.38	46.00	12.00	2.13	32	969	970	1884
38	52.25	3.44	45.69	43.50		38.25	6.44	5.50	48.00	12.00	2.13	32	1057	1062	2094
40	54.25	3.56	47.94	45.75		40.25	6.56	5.50	50.25	12.25	2.13	36	1158	1172	2336
42	57.00	3.69	50.44	47.75		42.25	6.94	5.62	52.75	12.50	2.13	36	1318	1288	2673
44	59.25	3.75	52.69	49.75		44.25	7.00	5.75	55.00	12.75	2.13	36	1423	1397	2935
46	61.50	3.88	54.94	51.75		46.25	7.12	5.88	57.25	13.00	2.13	40	1536	1510	3272
48	65.00	4.00	58.44	54.00		48.25	7.25	6.00	60.75	13.25	2.13	40	1824	1797	3768

Dimensions are in inches. Weights are in pounds.

Note: *AWWA Pressure rating at atmospheric temperature is 300 psi. These flanges have the same OD and drilling as ANSI/ASME B16.1 class 250 cast iron pipe and flanged fittings.

Industry Standard Class 75 Slip-On & Blind

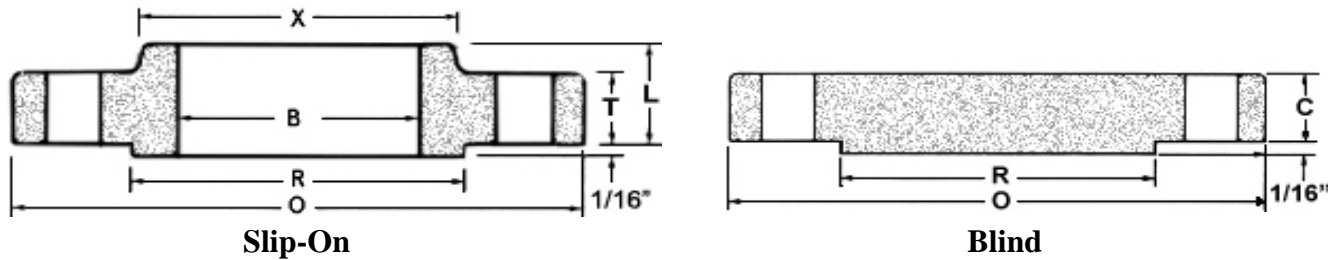

Nom Size	Thickness							Drilling				Weight	
	OD	Slip On	Blind	OD of RF	Dia at Base	Bore	LTH	Bolt Circle	Bolt Length	Hole Dia	# of Holes	Slip On	Blind
	O	T	C	R	X	B	L						
26	33.00	1.25	1.25	30.00	28.50	26.25	2.25	31.00	5.00	1.00	32	120	290
28	35.00	1.25	1.25	32.00	30.50	28.25	2.25	33.00	5.25	1.00	36	360	360
30	37.00	1.25	1.38	34.00	32.50	30.25	2.25	35.00	5.25	1.00	36	150	405
32	39.50	1.25	1.50	36.25	34.63	32.25	2.50	37.38	5.50	1.13	40	170	500
34	41.50	1.25	1.63	38.25	36.63	34.25	2.50	39.38	5.75	1.13	40	180	600
36	43.50	1.25	1.63	40.25	38.63	36.25	2.50	41.38	5.75	1.13	44	190	660
42	50.00	1.25	1.88	46.50	44.75	42.25	2.75	47.75	6.25	1.25	48	235	1000
48	56.00	1.25	2.13	52.50	50.75	48.25	2.88	53.75	6.50	1.25	56	270	1450
54	62.50	2.38	2.38	59.00	57.25	54.25	3.13	60.25	6.75	1.25	68	335	2000
60	68.50	1.63	2.63	65.00	63.25	60.25	3.63	66.25	7.25	1.25	72	450	2675
66	75.50	1.75	2.88	71.63	69.50	66.25	4.00	73.00	8.00	1.38	72	590	3550
72	81.50	2.00	3.13	77.63	75.50	72.25	4.50	79.00	8.50	1.38	80	730	4500

Dimensions are in inches. Weights are in pounds.

Note: Larger sizes as well as intermediate sizes can be furnished. When ordering Industry Standard Class 75 blinds specify if they are to be used with Weld Neck or Slip On flanges as the blinds differ between the two.

- (a) Bores listed are most common. They can be specified by customer were applicable.
- (b) Bolt lengths are calculated based on bolting one slip-on to one blind. Any other bolting combination will cause variance in bolt length.
- (c) Bolt hole diameter 1/8in. larger than bolt diameter.

Industry Standard Class 175

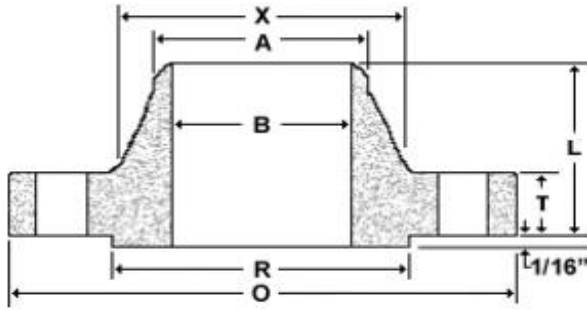

Weld Neck

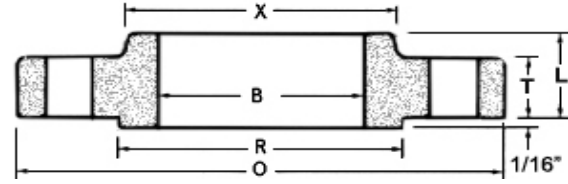

Slip-On

Nom Size	Thickness				OD of RF	Dia at Base	Bore		LTH		Dia Bevel
	OD	Weld Neck	Slip-On	Blind			Weld Neck	Slip-On	Weld Neck	Slip-On	
	O	T	T		R	X	B	B	L	L	A
26	31.50	1.38	1.38	1.78	29.00	27.63	To be specified by Purchaser.	26.25	3.38	2.75	To be established by design requirements.
28	33.50	1.38	1.38	2.00	31.00	29.63		28.25	3.38	2.75	
30	35.75	1.38	1.38	2.13	33.25	31.88		30.25	3.63	2.75	
32	37.75	1.38	1.38	2.25	35.25	33.88		32.25	3.63	2.75	
34	40.25	1.50	1.75	2.38	37.38	35.88		34.25	3.75	3.38	
36	42.25	1.50	1.75	2.50	39.38	37.88		36.25	3.75	3.38	
38	44.25	1.75	2.00	2.63	41.38	39.88		38.25	4.13	3.75	
40	46.25	1.75	2.00	2.75	43.38	41.88		40.25	4.13	4.00	
42	49.00	2.00	2.38	2.88	45.75	44.13		42.25	4.50	4.38	
44	51.00	2.00	2.38	3.00	47.75	46.13		44.25	4.50	4.38	
46	53.00	2.00	2.38	3.13	49.75	48.13		46.25	4.50	4.63	
48	55.00	2.25	2.63	3.38	51.75	50.13		48.25	4.88	4.88	
50	57.00	2.25	2.63	3.38	53.75	52.13		50.25	4.88	4.88	
52	59.50	2.63	3.00	3.63	56.00	54.25		52.25	5.38	5.38	
54	61.50	2.63	3.00	3.63	58.00	56.25		54.25	5.38	5.38	
60	67.50	2.75	3.13	4.00	64.00	62.25		60.25	5.75	5.88	
66	73.50	3.13	4.00	4.38	70.00	68.50	66.25	6.13	6.88		
72	80.00	3.63	5.00	4.75	76.50	74.50	72.25	6.63	8.00		
84	94.00	3.00	5.00	5.50	90.13	88.00	84.25	7.00	8.50		
96	106.00	3.50	5.00	6.12	102.13	100.00	96.25	7.50	9.00		

Dimensions are in inches. Weights are in pounds.

Continued on next page

Industry Standard Class 175

Continued

Nom Size	Drilling				Weight		
	Bolt Circle	Bolt Length a	Hole Dia b	# of Holes	Weld Neck	Slip On	Blind
26	29.88	5.50	0.88	28	120	105	405
28	31.88	5.75	0.88	28	130	115	490
30	34.13	5.75	0.88	36	150	130	590
32	36.13	6.00	0.88	36	160	140	700
34	38.38	6.75	1.00	36	195	200	840
36	40.38	6.75	1.00	36	205	210	970
38	42.38	7.25	1.00	36	245	250	1125
40	44.38	7.25	1.00	40	255	270	1300
42	46.88	8.00	1.13	40	340	365	1500
44	48.88	8.25	1.13	40	360	380	1700
46	50.88	8.25	1.13	40	375	410	1925
48	52.88	8.75	1.13	44	430	460	2225
50	54.88	8.75	1.13	44	450	480	2400
52	57.25	9.75	1.25	44	560	600	2800
54	59.25	9.75	1.25	44	580	620	3000
60	65.25	10.25	1.25	48	680	730	4000
66	71.25	11.50	1.25	56	830	1000	5175
72	77.75	12.75	1.25	64	1075	1400	6650
84	91.5	13.75	1.38	72	1550	2250	-
96	103.5	14.25	1.38	88	1950	2600	-

Dimensions are in inches. Weights are in pounds.

Note: Sizes are nominal inside diameters of pipe or shell used with Welding Neck flanges, and nominal OD of pipe or shell used with Slip-On flanges.

Larger sizes as well as intermediate sizes can be furnished.

- (a) Bolt lengths are calculated based on bolting one slip-on to one blind. Any other bolting combination will cause variance in bolt length.
- (b) Bolt hole diameter 1/8in. larger than bolt diameter.

Industry Standard Class 350

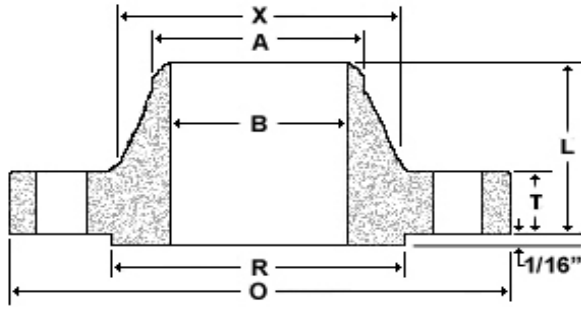

Weld Neck

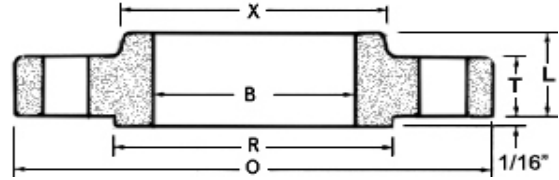

Slip-On

Nom Size	Thickness						Bore		LTH		Dia Bevel
	OD	Weld Neck	Slip-On	Blind	OD of RF	Dia at Base	Weld Neck	Slip-On	Weld Neck	Slip-On	
	O	T	T		R	X	B	B	L	L	
26	32.75	2.50	2.50	2.75	29.50	27.88	To be specified by purchaser.	26.25	5.00	4.50	To be established by design requirements.
28	34.75	2.50	2.50	2.88	31.50	29.88		28.25	5.00	4.50	
30	37.00	2.63	2.63	3.00	33.75	32.13		30.25	5.25	4.75	
32	39.00	2.75	2.75	3.25	35.75	34.13		32.25	5.50	5.00	
34	41.00	2.88	2.88	3.38	37.75	36.13		34.25	5.75	5.13	
36	43.75	3.13	3.13	3.63	40.25	38.50		36.25	6.13	5.63	
38	45.75	3.13	3.13	3.75	42.25	40.50		38.25	6.13	5.63	
40	47.75	3.25	3.25	4.00	44.25	42.50		40.25	6.25	5.88	
42	50.00	3.50	3.50	4.13	46.50	44.75		42.25	6.50	6.13	
44	52.75	3.75	3.75	4.38	48.88	46.75		44.25	6.75	6.75	
46	54.75	4.25	4.25	4.75	50.88	48.75		46.25	7.25	7.25	
48	56.75	4.25	4.25	4.75	52.88	50.75		48.25	7.25	7.25	
52	61.50	4.25	-	-	57.25	55.00		52.25	7.50	-	
54	63.50	4.50	4.75	-	59.25	57.00		54.25	7.75	8.25	
60	69.50	4.50	5.00	-	65.25	63.00		60.25	8.00	8.50	
66	77.00	4.00	-	-	72.38	70.00		66.25	8.50	-	
72	83.00	4.00	-	-	78.38	76.00	72.25	9.00	-		

Dimensions are in inches. Weights are in pounds.

Continued on next page

Industry Standard Class 350

Continued

Nom Size	Drilling				Weight		
	Bolt Circle	Bolt Length a	Hole Dia b	# of Holes	Weld Neck	Slip On	Blind
26	30.63	8.00	1.13	28	245	225	580
28	32.63	8.25	1.13	28	260	250	750
30	34.88	8.50	1.13	32	305	295	890
32	36.88	8.75	1.13	36	340	325	1050
34	38.88	9.00	1.13	40	375	355	1225
36	41.50	9.75	1.25	40	480	465	1500
38	43.50	10.00	1.25	40	510	490	1700
40	45.50	10.25	1.25	44	540	530	1975
42	47.75	10.75	1.25	48	640	620	2225
44	50.25	11.50	1.38	44	760	760	2625
46	52.25	12.25	1.38	48	880	880	2950
48	54.25	12.25	1.38	48	920	920	3300
52	58.75	-	1.50	52	1075	-	-
54	60.75	-	1.50	52	1200	1150	-
60	66.75	-	1.50	60	1325	1450	-
66	74.00	-	1.63	60	1675	-	-
72	80.00	-	1.63	72	1850	-	-

Dimensions are in inches. Weights are in pounds.

Flanges and nominal OD of pipe or shell used with Slip-On flanges. Larger sizes as well as intermediate sizes can be furnished.

*Bolt Length figured on Slip-On/Blind bolting combination. Other combinations may

1. Bolt lengths are calculated based on bolting one slip-on to one blind. Any other bolting combination will cause variance in bolt length.
2. Bolt hole diameter 1/8in. larger than bolt diameter.

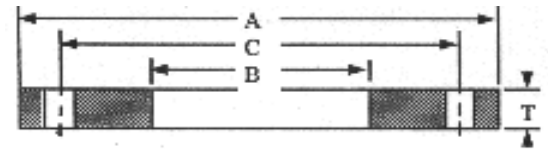

AWWA Standard Steel-Ring Flange (86 psi*), Table 2 Class B (Blinds from Table 7)

Nom Size	Thickness			Drilling			# of Holes	Weight	
	OD	Slip-On	Blind	Bore	Bolt Circle	Hole Dia		Slip-on	Blind
	A	T	T	B	C				
4	9.00	0.625	0.625	4.57	7.50	0.750	8	8	11
5	10.00	0.625	0.625	5.66	8.50	0.875	8	9	14
6	11.00	0.688	0.688	6.72	9.50	0.875	8	11	19
8	13.50	0.688	0.688	8.72	11.75	0.875	8	15	28
10	16.00	0.688	0.688	10.88	14.25	1.000	12	19	39
12	19.00	0.688	0.719	12.88	17.00	1.000	12	28	58
14	21.00	0.688	0.791	14.19	18.75	1.125	12	34	78
16	23.50	0.688	0.892	16.19	21.25	1.125	16	41	110
18	25.00	0.688	0.950	18.19	22.75	1.250	16	41	132
20	27.50	0.688	1.040	20.19	25.00	1.250	20	49	175
22	29.50	0.750	1.132	22.19	27.25	1.375	20	57	219
24	32.00	0.750	1.216	24.19	29.50	1.375	20	67	277
26	34.25	0.812	1.307	26.19	31.75	1.375	24	80	341
28	36.50	0.875	1.398	28.19	34.00	1.375	28	94	414
30	38.75	0.875	1.477	30.19	36.00	1.375	28	105	493
32	41.75	0.936	1.581	32.19	38.50	1.625	28	132	613
34	43.75	0.938	1.661	34.19	40.50	1.625	32	137	707
36	46.00	1.000	1.751	36.19	42.75	1.625	32	161	824
38	48.75	1.000	1.853	38.19	45.25	1.625	32	185	980
40	50.75	1.000	1.933	40.19	47.25	1.625	36	193	1108
42	53.00	1.125	2.023	42.19	49.50	1.625	36	234	1264
44	55.25	1.125	2.114	44.19	51.75	1.625	40	249	1436
46	57.25	1.125	2.194	46.19	53.75	1.625	40	260	1600
48	59.50	1.250	2.285	48.19	56.00	1.625	44	306	1800
50	61.75	1.250	2.377	50.19	58.25	1.875	44	317	2017
52	64.00	1.250	2.468	52.19	60.50	1.875	44	339	2249
54	66.25	1.375	2.559	54.19	62.75	1.875	44	397	2499
60	73.00	1.500	2.820	60.19	69.25	1.875	52	508	3344
66	80.00	1.625	3.092	66.19	76.00	1.875	52	664	4403
72	86.50	1.750	3.353	72.19	82.50	1.875	60	802	5582
78	93.00	2.000	78.19	89.00	2.125	64	1000
84	99.75	2.000	84.19	95.50	2.125	64	1145
90	106.50	2.250	90.19	102.00	2.438	68	1404
96	113.25	2.250	96.19	108.50	2.438	68	1586
102	120.00	2.500	102.19	114.50	2.688	72	1912
108	126.75	2.500	108.19	120.75	2.688	72	2136
114	133.50	2.750	114.19	126.75	2.938	76	2525
120	140.25	2.750	120.19	132.75	2.938	76	2795
126	147.00	3.000	126.19	139.25	3.188	80	3252
132	153.75	3.000	132.19	145.75	3.188	80	3572
138	160.50	3.250	138.19	152.00	3.438	84	4101
144	167.25	3.250	144.19	158.25	3.438	84	4475

Dimensions are in inches. Weights are in pounds.

Note: *Pressure rating at atmospheric temperature is 86 psi. These flanges have the same OD and drilling as ANSI/ASME B16.1 class 125 cast-iron flanges. In sizes 24in. and smaller, they also match ANSI/ASME B16.5 150-psi standard for steel flanges.

AWWA Standard Steel-Ring Flange (175-150 psi*), Table 2 Class D (Blinds from Table 7)

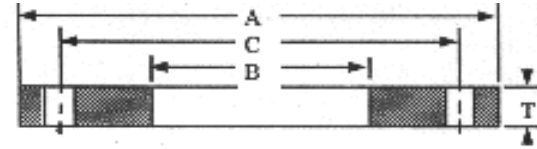

Nom Size	Thickness			Drilling			Weight		
	OD	Slip-On	Blind	Bore	Bolt Circle	Hole Dia	# of Holes	Slip-on	Blind
	A	T	T	B	C				
4	9.00	0.625	0.625	4.57	7.50	0.750	8	8	11
5	10.00	0.625	0.650	5.66	8.50	0.875	8	9	14
6	11.00	0.688	0.693	6.72	9.50	0.875	8	11	19
8	13.50	0.688	0.812	8.72	11.75	0.875	8	15	33
10	16.00	0.688	0.953	10.88	14.25	1.000	12	19	54
12	19.00	0.812	1.117	12.88	17.00	1.000	12	33	90
14	21.00	0.938	1.133	14.19	18.75	1.125	12	47	111
16	23.50	1.000	1.265	16.19	21.25	1.125	16	60	155
18	25.00	1.062	1.331	18.19	22.75	1.250	16	64	185
20	27.50	1.125	1.448	20.19	25.00	1.250	20	79	244
22	29.50	1.188	1.568	22.19	27.25	1.375	20	90	304
24	32.00	1.250	1.661	24.19	29.50	1.375	20	112	378
26	34.25	1.312	1.786	26.19	31.75	1.375	24	129	466
28	36.50	1.312	1.906	28.19	34.00	1.375	28	141	565
30	38.75	1.375	2.008	30.19	36.00	1.375	28	164	671
32	41.75	1.500	2.150	32.19	38.50	1.625	28	211	834
34	43.75	1.500	2.252	34.19	40.50	1.625	32	220	959
36	46.00	1.625	2.370	36.19	42.75	1.625	32	261	1116
38	48.75	1.625	2.506	38.19	45.25	1.625	32	301	1325
40	50.75	1.625	2.609	40.19	47.25	1.625	36	313	1438
42	53.00	1.750	2.729	42.19	49.50	1.625	36	364	1706
44	55.25	1.750	2.849	44.19	51.75	1.625	40	387	1935
46	57.25	1.750	2.952	46.19	53.75	1.625	40	404	2153
48	59.50	1.875	3.072	48.19	56.00	1.625	44	460	2420
50	61.75	2.000	3.196	50.19	58.25	1.875	44	507	2712
52	64.00	2.000	3.315	52.19	60.50	1.875	44	542	3021
54	66.25	2.125	3.435	54.19	62.75	1.875	44	614	3355
60	73.00	2.250	3.779	60.19	69.25	1.875	52	763	4481
66	80.00	2.500	4.136	66.19	76.00	1.875	52	1021	5890
72	86.50	2.625	4.480	72.19	82.50	1.875	60	1203	7458
78	93.00	2.750	78.19	89.00	2.125	64	1374
84	99.75	2.875	84.19	95.50	2.125	64	1646
90	106.50	3.000	90.19	102.00	2.438	68	1872
96	113.25	3.250	96.19	108.50	2.438	68	2291
102	120.00	3.250	102.19	114.50	2.688	72	2485
108	126.75	3.375	108.19	120.75	2.688	72	2884
114	133.50	3.500	114.19	126.75	2.938	76	3214
120	140.25	3.500	120.19	132.75	2.938	76	3558
126	147.00	3.750	126.19	139.25	3.188	80	4065
132	153.75	3.875	132.19	145.75	3.188	80	4614
138	160.50	4.000	138.19	152.00	3.438	84	5047
144	167.25	4.125	144.19	158.25	3.438	84	5680

Dimensions are in inches. Weights are in pounds.

Note: *Pressure rating at atmospheric temperature: sizes 4-12 in. inclusive, 175 psi; sizes larger than 12 in., 150 psi. These flanges have the same OD and drilling as ANSI/ASME B16.1 class 125 cast-iron flanges. In sizes 24in. and smaller, they also match ANSI/ASME B16.5 150-psi standard for steel flanges.

AWWA Standard Steel-Hub Flange (175-150 psi), Table 3 Class D

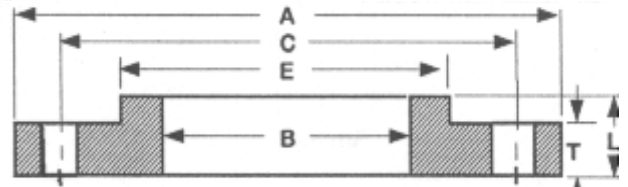

Nom Size	Drilling								
	OD	Thickness	Overall Thickness	Dia at Base	Bore	Bolt Circle	Hole Dia	# of Holes	Weight
	A	T	L	E	B	C			
4	9.00	0.500	0.875	5.312	4.57	7.50	0.750	8	7
5	10.00	0.562	1.250	6.312	5.66	8.50	0.875	8	9
6	11.00	0.562	1.250	7.562	6.72	9.50	0.875	8	11
8	13.50	0.562	1.250	9.688	8.72	11.75	0.875	8	15
10	16.00	0.688	1.250	12.000	10.88	14.25	1.000	12	22
12	19.00	0.688	1.250	14.375	12.88	17.00	1.000	12	33
14	21.00	0.750	1.250	15.750	14.19	18.75	1.125	12	43
16	23.50	0.750	1.250	18.000	16.19	21.25	1.125	16	52
18	25.00	0.750	1.250	19.875	18.19	22.75	1.250	16	52
20	27.50	0.750	1.250	22.000	20.19	25.00	1.250	20	61
22	29.50	1.000	1.750	24.250	22.19	27.25	1.375	20	92
24	32.00	1.000	1.750	26.125	24.19	29.50	1.375	20	105
26	34.25	1.000	1.750	28.500	26.19	31.75	1.375	24	119
28	36.50	1.000	1.750	30.500	28.19	34.00	1.375	28	130
30	38.75	1.000	1.750	32.500	30.19	36.00	1.375	28	144
32	41.75	1.125	1.750	34.750	32.19	38.50	1.625	28	182
34	43.75	1.125	1.750	36.750	34.19	40.50	1.625	32	191
36	46.00	1.125	1.750	38.750	36.19	42.75	1.625	32	207
38	48.75	1.125	1.750	40.750	38.19	45.25	1.625	32	237
40	50.75	1.125	1.750	43.000	40.19	47.25	1.625	36	249
42	53.00	1.250	1.750	45.000	42.19	49.50	1.625	36	287
44	55.25	1.250	2.250	47.000	44.19	51.75	1.625	40	334
46	57.25	1.250	2.250	49.000	46.19	53.75	1.625	40	348
48	59.50	1.375	2.500	51.000	48.19	56.00	1.625	44	407
50	61.75	1.375	2.500	53.000	50.19	58.25	1.875	44	421
52	64.00	1.375	2.500	55.000	52.19	60.50	1.875	44	448
54	66.25	1.375	2.500	57.000	54.19	62.75	1.875	44	475
60	73.00	1.500	2.750	63.000	60.19	69.25	1.875	52	605
66	80.00	1.500	2.750	69.000	66.19	76.00	1.875	52	718
72	86.50	1.500	2.750	75.000	72.19	82.50	1.875	60	803
78	93.00	1.750	3.000	81.250	78.19	89.00	2.125	64	1010
84	99.75	1.750	3.000	87.500	84.19	95.50	2.125	64	1160
90	106.50	2.000	3.250	93.750	90.19	102.00	2.438	68	1430
96	113.25	2.000	3.250	100.000	96.19	108.50	2.438	68	1618

Dimensions are in inches. Weights are in pounds.

Note: Hub flanges are to be used on pipe that has an OD equal to the nominal pipe size in the first column.

*Pressure rating at atmospheric temperature: sizes 4-12 in. inclusive, 175 psi; sizes larger than 12 in., 150 psi. These flanges have the same OD and drilling as ANSI/ASME B16.1 class 125 cast-iron flanges. In sizes 24in. and smaller, they also match ANSI/ASME B16.5 150-psi standard for steel flanges.

AWWA Standard Steel-Hub Flange (275 psi*), Table 4 Class E

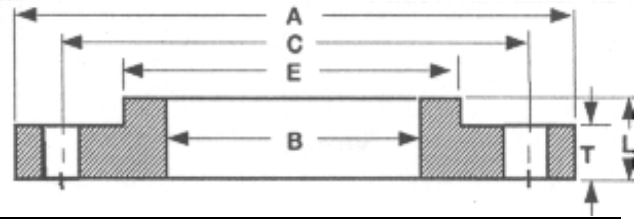

Nom Size	Drilling								
	OD	Thickness	Overall Thickness	Dia at Base	Bore	Bolt Circle	Hole Dia	# of Holes	Weight
	A	T	L	E	B	C			
4	9.00	0.938	1.312	5.312	4.57	7.50	0.750	8	13
5	10.00	0.938	1.438	6.438	5.66	8.50	0.875	8	14
6	11.00	1.000	1.562	7.562	6.72	9.50	0.875	8	17
8	13.50	1.125	1.750	9.688	8.72	11.75	0.875	8	28
10	16.00	1.188	1.938	12.000	10.88	14.25	1.000	12	37
12	19.00	1.250	2.188	14.375	12.88	17.00	1.000	12	59
14	21.00	1.375	2.250	15.750	14.19	18.75	1.125	12	78
16	23.50	1.438	2.500	18.000	16.19	21.25	1.125	16	101
18	25.00	1.562	2.688	19.875	18.19	22.75	1.250	16	110
20	27.50	1.688	2.875	22.000	20.19	25.00	1.250	20	139
22	29.00	1.812	3.125	24.000	22.19	27.25	1.375	20	1162
24	32.00	1.875	3.250	26.125	24.19	29.50	1.375	20	197
26	34.25	2.000	3.375	28.500	26.19	31.75	1.375	24	235
28	36.50	2.062	3.438	30.750	28.19	34.00	1.375	28	269
30	38.75	2.125	3.500	32.750	30.19	36.00	1.375	28	303
32	41.75	2.250	3.625	35.000	32.19	38.50	1.625	28	375
34	43.75	2.312	3.688	37.000	34.19	40.50	1.625	32	401
36	46.00	2.375	3.750	39.250	36.19	42.75	1.625	32	452
38	48.75	2.375	3.750	41.750	38.19	45.25	1.625	32	528
40	50.75	2.500	3.875	43.750	40.19	47.25	1.625	36	573
42	53.00	2.625	4.000	46.000	42.19	49.50	1.625	36	648
44	55.25	2.625	4.000	48.000	44.19	51.75	1.625	40	688
46	57.25	2.688	4.062	50.000	46.19	53.75	1.625	40	733
48	59.50	2.750	4.125	52.250	48.19	56.00	1.625	44	799
50	61.75	2.750	4.125	54.250	50.19	58.25	1.875	44	827
52	64.00	2.875	4.250	56.500	52.19	60.50	1.875	44	922
54	66.25	3.000	4.375	58.750	54.19	62.75	1.875	44	1024
60	73.00	3.125	4.500	65.250	60.19	69.25	1.875	52	1253
66	80.00	3.375	4.875	71.500	66.19	76.00	1.875	52	1623
72	86.50	3.500	5.000	78.500	72.19	82.50	1.875	60	1922
78	93.00	3.875	5.375	84.500	78.19	89.00	2.125	64	2279
84	99.75	3.875	5.375	90.500	84.19	95.50	2.125	64	2586
90	106.50	4.250	5.750	96.750	90.19	102.00	2.438	68	3061
96	113.25	4.250	5.750	102.750	96.19	108.50	2.438	68	3432

Dimensions are in inches. Weights are in pounds.

Note: Hub flanges are to be used on pipe that has an OD equal to the nominal pipe size in the first column.

*Pressure rating at atmospheric temperature is 275 psi. These flanges have the same OD and drilling as ANSI/ASME B16.1 class 125 cast-iron flanges. In sizes 24in. and smaller, they also match ANSI/ASME B16.5 class 150 standard for steel flanges. The thickness of a class 150 flange from which the raised face has been removed shall be no less than dimension T minus 0.06 in.

AWWA Standard Steel-Ring Flange (275 psi*), Table 5 Class E (Blinds from Table 7)

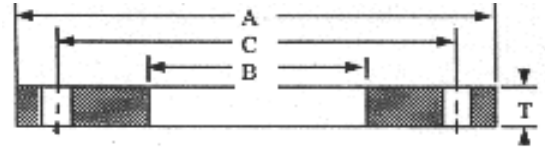

Nom Size	Thickness			Drilling			Weight		
	OD	Slip-On	Blind	Bore	Bolt Circle	Hole Dia	# of Holes	Slip-on	Blind
	A	T	T	B	C				
4	9.00	1.125	1.125	4.57	7.50	0.750	8	14	20
5	10.00	1.188	1.188	5.66	8.50	0.875	8	16	26
6	11.00	1.313	1.313	6.72	9.50	0.875	8	20	35
8	13.50	1.500	1.500	8.72	11.75	0.875	8	33	61
10	16.00	1.563	1.563	10.88	14.25	1.000	12	44	89
12	19.00	1.750	1.750	12.88	17.00	1.000	12	71	141
14	21.00	1.875	1.875	14.19	18.75	1.125	12	94	184
16	23.50	2.000	2.000	16.19	21.25	1.125	16	120	246
18	25.00	2.125	2.125	18.19	22.75	1.250	16	127	296
20	27.50	2.375	2.375	20.19	25.00	1.250	20	168	400
22	29.50	2.500	2.500	22.19	27.25	1.375	20	189	484
24	32.00	2.625	2.625	24.19	29.50	1.375	20	234	598
26	34.25	2.750	2.750	26.19	31.75	1.375	24	270	718
28	36.50	2.750	2.750	28.19	34.00	1.375	28	297	815
30	38.5	2.75	2.75	30.19	36.0	1.75	28	344	961
32	41.75	3.000	3.000	32.19	38.50	1.625	28	422	1163
34	43.75	3.000	3.050	34.19	40.50	1.625	32	441	1299
36	46.00	3.125	3.209	36.19	42.75	1.625	32	502	1511
38	48.75	3.125	3.394	38.19	45.25	1.625	32	580	1795
40	50.75	3.250	3.533	40.19	47.25	1.625	36	626	2025
42	53.00	3.375	3.695	42.19	49.50	1.625	36	701	2309
44	55.25	3.375	3.857	44.19	51.75	1.625	40	747	2715
46	57.25	3.438	3.997	46.19	53.75	1.625	40	794	2813
48	59.50	3.500	4.159	48.19	56.00	1.625	44	858	3276
50	61.75	3.500	4.327	50.19	58.25	1.875	44	887	3671
52	64.00	3.625	4.489	52.19	60.50	1.875	44	982	4091
54	66.25	3.750	4.651	54.19	62.75	1.875	44	1083	4542
60	73.00	3.875	5.116	60.19	69.25	1.875	52	1313	6066
66	80.00	4.250	5.601	66.19	76.00	1.875	52	1736	7976
72	86.50	4.375	6.066	72.19	82.50	1.875	60	2005	10099
78	93.00	4.750	78.19	89.00	2.125	64	2374
84	99.75	4.750	84.19	95.50	2.125	64	2719
90	106.50	5.125	90.19	102.00	2.438	68	3197
96	113.25	5.125	96.19	108.50	2.438	68	3613
102	120.00	5.500	102.19	114.50	2.688	72	4206
108	126.75	5.500	108.19	120.75	2.688	72	4700
114	133.50	5.875	114.19	126.75	2.938	76	5395
120	140.25	5.875	120.19	132.75	2.938	76	5972
126	147.00	6.250	126.19	139.25	3.188	80	6775
132	153.75	6.250	132.19	145.75	3.188	80	7442
138	160.50	6.750	138.19	152.00	3.438	84	8517
144	167.25	6.750	144.19	158.25	3.438	84	9295

Dimensions are in inches. Weights are in pounds.

Note: *Pressure rating at atmospheric temperature is 275 psi. These flanges have the same OD and drilling as ANSI/ASME B16.1 class 125 cast-iron flanges. In sizes 24in. and smaller, they also match ANSI/ASME B16.5 150-psi standard for steel flanges.

AWWA Standard Steel-Ring Flange (300 psi*), Table 6 Class F (Blinds from Table 7)

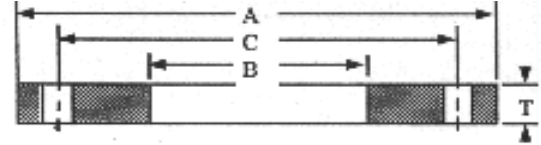

Nom Size	Thickness			Drilling			Weight		
	OD	Slip-On	Blind	Bore	Bolt Circle	Hole Dia	# of Holes	Slip-on	Blind
	A	T	T	B	C				
4	10.00	1.130	1.130	4.57	7.88	0.875	8	18	25
5	11.00	1.210	1.210	5.66	9.25	0.875	8	22	33
6	12.50	1.310	1.310	6.73	10.62	0.875	12	30	46
8	15.00	1.310	1.310	8.73	13.00	1.000	12	40	66
10	17.50	1.500	1.500	10.88	15.25	1.125	16	56	102
12	20.50	1.630	1.630	12.88	17.75	1.250	16	83	152
14	23.00	1.940	1.940	14.19	20.25	1.250	20	128	228
16	25.50	2.140	2.140	16.19	22.50	1.375	20	167	310
18	28.00	2.250	2.250	18.19	24.75	1.375	24	204	392
20	30.50	2.330	2.330	20.19	27.00	1.375	24	247	482
22	33.00	2.500	2.500	22.19	29.25	1.375	24	307	606
24	36.00	2.690	2.690	24.19	32.00	1.625	24	388	776
26	38.25	3.000	3.000	26.19	34.50	1.875	28	451	977
28	40.75	3.130	3.130	28.19	37.00	1.875	28	532	1156
30	43.00	3.150	3.166	30.19	39.25	1.875	28	586	1303
32	45.25	3.250	3.332	32.19	41.50	1.875	28	657	1518
34	47.50	3.380	3.475	34.19	43.50	1.875	28	741	1745
36	50.00	3.460	3.671	36.19	46.00	2.125	32	802	2042
38	52.25	3.500	3.815	38.19	48.00	2.125	32	874	2317
40	54.25	3.630	3.982	40.19	50.25	2.125	36	937	2608
42	57.00	3.810	4.171	42.19	52.75	2.125	36	1103	3015
44	59.25	4.000	4.338	44.19	55.00	2.125	36	1237	3388
46	61.50	4.130	4.505	46.19	57.25	2.125	40	1344	3791
48	65.00	4.500	4.781	48.19	60.75	2.125	40	1718	4494

Dimensions are in inches. Weights are in pounds.

Note: *Pressure rating at atmospheric temperature is 300 psi. These flanges have the same OD and drilling as ANSI/ASME B16.1 class 250 cast-iron pipe and flanged fittings.

Class 150 – Long Weld Neck

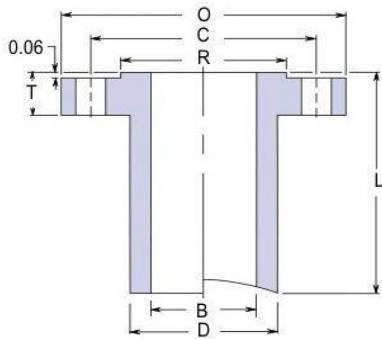

LONG WELD NECK "LWN"

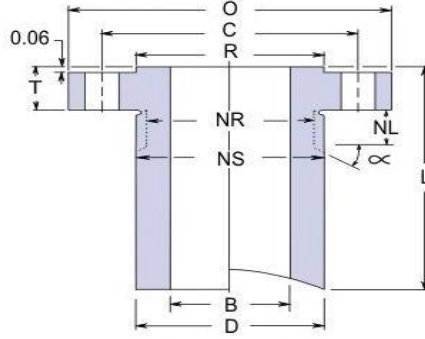

HEAVY BARREL "HB"

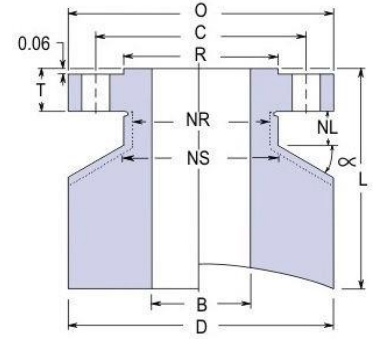

EQUAL BARREL "E"

Nom	Size		Flange			Barrel OD			Bolting			Nut			Stud Bolt			Weights						Length
	Bore LWN & E	Bore HB	OD	Thk	RF of OD	LWN	HB	E	# of Holes	Hole Size	Bolt Circle	Stop Dia	Relief Dia	Relief Length	Size	RF Length	RTJ Length	LWN		HB		E		Base
	B	B	O	T	R	D	D	D			C	NS	NR	NL				Base	Per 1"	Base	Per 1"	Base	Per 1"	L
1/2	0.50	0.55	3.50	0.44	1.38	1.25	1.50	3.50	4	0.62	2.38	1.50	1.25	0.75	1/2	2 1/4	2 3/4	3	0.3	5	0.4	21	2.7	9
3/4	0.75	0.74	3.88	0.50	1.69	1.62	1.88	3.88	4	0.62	2.75	1.88	1.62	0.75	1/2	2 1/2	3	5	0.5	7	0.7	27	3.2	9
1	1.00	0.96	4.25	0.56	2.00	2.00	2.25	4.25	4	0.62	3.12	2.25	2.00	0.75	1/2	2 1/2	3	7	0.7	10	0.9	30	3.8	9
1 1/4	1.25	1.28	4.62	0.62	2.50	2.38	2.62	4.62	4	0.62	3.50	2.62	2.38	0.75	1/2	2 3/4	3 1/4	10	0.9	12	1.2	36	4.4	9
1 1/2	1.50	1.50	5.00	0.69	2.88	2.62	3.00	5.00	4	0.62	3.88	3.00	2.62	0.75	1/2	2 3/4	3 1/4	12	1	16	1.5	41	5.1	9
2	2.00	1.94	6.00	0.75	3.62	3.06	3.69	6.00	4	0.75	4.75	3.69	3.06	0.88	5/8	3 1/4	3 3/4	15	1.2	23	2.2	57	7.1	9
2 1/2	2.50	2.32	7.00	0.88	4.12	3.75	4.44	7.00	4	0.75	5.50	4.44	3.75	0.88	5/8	3 1/2	4	22	1.7	34	3.2	79	10	9
3	3.00	2.90	7.50	0.94	5.00	4.25	4.94	7.50	4	0.75	6.00	4.94	4.25	0.88	5/8	3 1/2	4 1/4	25	2	38	3.6	86	11	9
3 1/2	3.50	3.36	8.50	0.94	5.50	4.88	5.94	8.50	8	0.75	7.00	5.94	4.88	0.88	5/8	3 1/2	4 1/4	32	2.6	55	5.3	110	13	9
4	4.00	3.83	9.00	0.94	6.19	5.50	6.44	9.00	8	0.75	7.50	6.44	5.50	0.88	5/8	3 1/2	4 1/4	47	3.2	78	6	164	14	12
5	5.00	4.81	10.00	0.94	7.31	6.50	7.25	10.00	8	0.88	8.50	7.25	6.50	1.00	3/4	3 3/4	4 1/2	57	3.8	87	6.5	189	17	12
6	6.00	5.76	11.00	1.00	8.50	7.75	8.25	11.00	8	0.88	9.50	8.25	7.75	1.00	3/4	4	4 1/2	75	5.4	103	7.8	216	19	12
8	8.00	7.62	13.50	1.12	10.62	9.75	10.50	13.50	8	0.88	11.75	10.50	9.75	1.00	3/4	4 1/4	4 3/4	102	6.9	157	11	292	26	12
10	10.00	9.56	16.00	1.19	12.75	12.00	12.81	16.00	12	1.00	14.25	12.81	12.00	1.12	7/8	4 3/4	5 1/4	143	9.8	214	16	382	35	12
12	12.00	11.38	19.00	1.25	15.00	14.38	15.56	19.00	12	1.00	17.00	15.56	14.38	1.12	7/8	4 3/4	5 1/2	205	14	329	25	535	48	12
14	14.00	14.00	21.00	1.38	16.25	16.00	17.12	21.00	12	1.12	18.75	17.12	16.00	1.25	1	5 1/4	6	211	13	296	22	585	55	12
16	16.00	16.00	23.50	1.44	18.50	18.00	19.62	23.50	16	1.12	21.25	19.62	18.00	1.25	1	5 1/2	6	246	15	388	29	714	66	12
18	18.00	18.00	25.00	1.56	21.00	20.00	20.94	25.00	16	1.25	22.75	20.94	20.00	1.38	1 1/8	6	6 1/2	270	17	362	25	711	67	12
20	20.00	20.00	27.50	1.69	23.00	22.00	23.19	27.50	20	1.25	25.00	23.19	22.00	1.38	1 1/8	6 1/4	7	311	19	434	31	840	79	12
24	24.00	24.00	32.00	1.88	27.25	26.25	27.50	32.00	20	1.38	29.50	27.50	26.25	1.50	1 1/4	7	7 3/4	423	25	574	40	1046	100	12

Dimensions are in inches. Weights are in pounds.

Class 300 – Long Weld Neck

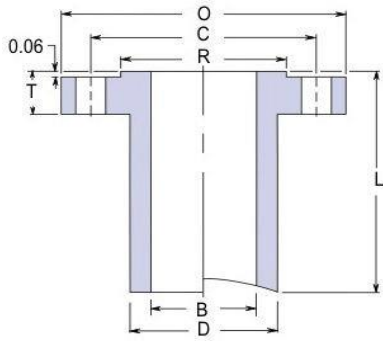

LONG WELD NECK "LWN"

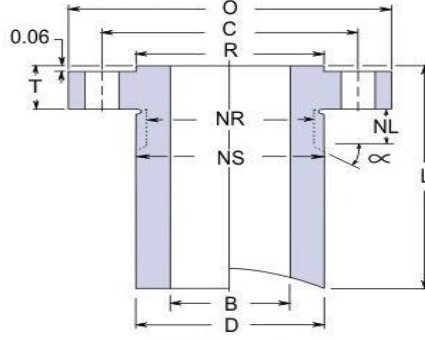

HEAVY BARREL "HB"

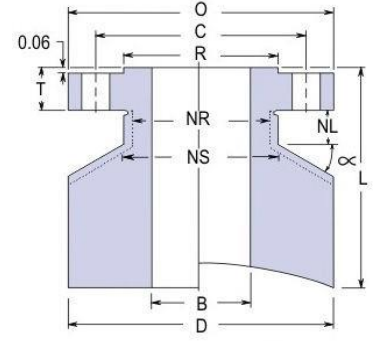

EQUAL BARREL "E"

Nom	Size		Flange			Barrel OD			Bolting			Nut			Stud Bolt			Weights						Length
	Bore LWN & E	Bore HB	OD	Thk	RF of OD	LWN	HB	E	# of Holes	Hole Size	Bolt Circle	Stop Dia	Relief Dia	Relief Length	Size	RF Length	RTJ Length	LWN		HB		E		Base
	B	B	O	T	R	D	D	D			C	NS	NR	NL				Base	Per 1"	Base	Per 1"	Base	Per 1"	L
1/2	0.50	0.55	3.75	0.56	1.38	1.50	1.75	3.75	4	0.62	2.62	1.75	1.50	0.75	1/2	2 1/2	3	5	0.4	7	0.6	24	3.1	9
3/4	0.75	0.74	4.62	0.62	1.69	1.88	2.19	4.62	4	0.75	3.25	2.19	1.88	0.88	5/8	3	3 1/2	9	0.7	11	0.9	37	4.6	9
1	1.00	0.96	4.88	0.69	2.00	2.12	2.44	4.88	4	0.75	3.50	2.44	2.12	0.88	5/8	3 1/4	3 1/2	9	0.8	12	1.1	40	5.1	9
1 1/4	1.25	1.28	5.25	0.75	2.50	2.50	2.81	5.25	4	0.75	3.88	2.81	2.50	0.88	5/8	3 1/4	3 3/4	13	1	15	1.4	45	5.8	9
1 1/2	1.50	1.50	6.12	0.81	2.88	2.75	3.25	6.12	4	0.88	4.50	3.25	2.75	1.00	3/4	3 1/2	4	15	1.2	21	1.9	61	7.8	9
2	2.00	1.94	6.50	0.88	3.62	3.31	3.94	6.50	8	0.75	5.00	3.94	3.31	0.88	5/8	3 1/2	4 1/4	20	1.5	28	2.6	68	8.5	9
2 1/2	2.50	2.32	7.50	1.00	4.12	3.94	4.62	7.50	8	0.88	5.88	4.62	3.94	1.00	3/4	4	4 1/2	25	2.1	38	3.6	89	11	9
3	3.00	2.90	8.25	1.12	5.00	4.62	5.38	8.25	8	0.88	6.62	5.38	4.62	1.00	3/4	4 1/4	5	35	2.7	49	4.6	106	13	9
3 1/2	3.50	3.36	9.00	1.19	5.50	5.25	6.00	9.00	8	0.88	7.25	6.00	5.25	1.00	3/4	4 1/4	5	42	3.4	59	5.5	122	15	9
4	4.00	3.83	10.00	1.25	6.19	5.75	6.62	10.00	8	0.88	7.88	6.62	5.75	1.00	3/4	4 1/2	5 1/4	62	3.8	91	6.5	207	19	12
5	5.00	4.81	11.00	1.38	7.31	7.00	8.00	11.00	8	0.88	9.25	8.00	7.00	1.00	3/4	4 3/4	5 1/4	84	5.3	124	9.1	241	21	12
6	6.00	5.76	12.50	1.44	8.50	8.12	9.38	12.50	12	0.88	10.62	9.38	8.12	1.00	3/4	4 3/4	5 3/4	105	6.7	165	12	303	27	12
8	8.00	7.62	15.00	1.62	10.62	10.25	11.56	15.00	12	1.00	13.00	11.56	10.25	1.12	7/8	5 1/2	6 1/4	148	9.1	228	17	405	36	12
10	10.00	9.56	17.50	1.88	12.75	12.62	13.62	17.50	16	1.12	15.25	13.62	12.62	1.25	1	6 1/4	7 1/4	210	13	291	21	499	46	12
12	12.00	11.38	20.50	2.00	15.00	14.75	15.94	20.50	16	1.25	17.75	15.94	14.75	1.38	1 1/8	6 3/4	7 1/2	275	16	392	28	651	61	12
14	14.00	14.00	23.00	2.12	16.25	16.75	18.44	23.00	20	1.25	20.25	18.44	16.75	1.38	1 1/8	7	7 3/4	324	19	456	32	785	74	12
16	16.00	16.00	25.50	2.25	18.50	19.00	20.50	25.50	20	1.38	22.50	20.50	19.00	1.50	1 1/4	7 1/2	8 1/2	404	23	529	37	914	88	12
18	18.00	18.00	28.00	2.38	21.00	21.00	22.75	28.00	24	1.38	24.75	22.75	21.00	1.50	1 1/4	7 3/4	8 1/4	465	26	630	43	1066	102	12
20	20.00	20.00	30.50	2.50	23.00	23.12	25.00	30.50	24	1.38	27.00	25.00	23.12	1.50	1 1/4	8 1/4	9 1/4	549	30	741	50	1228	118	12
24	24.00	24.00	36.00	2.75	27.25	27.62	29.62	36.00	24	1.62	32.00	29.62	27.62	1.75	1 1/2	9 1/4	10 1/4	778	42	1016	67	1627	160	12

Dimensions are in inches. Weights are in pounds.

Class 400 – Long Weld Neck

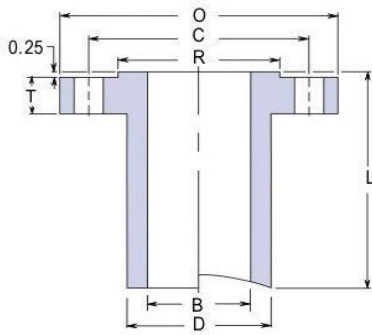

LONG WELD NECK "LWN"

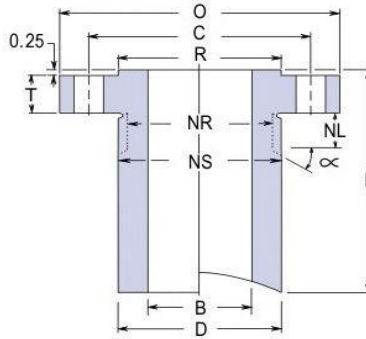

HEAVY BARREL "HB"

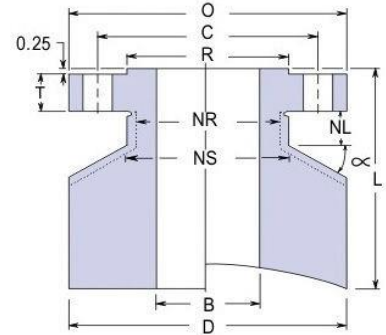

EQUAL BARREL "E"

Nom	Size		Flange			Barrel OD			Bolting			Nut			Stud Bolt			Weights						Length
	Bore LWN & E	Bore HB	OD	Thk	RF of OD	LWN	HB	E	# of Holes	Hole Size	Bolt Circle	Stop Dia	Relief Dia	Relief Length	Size	RF Length	RTJ Length	LWN		HB		E		Base
	B	B	O	T	R	D	D	D		C	NS	NR	NL					Base	Per 1"	Base	Per 1"	Base	Per 1"	L
1/2	0.50	0.55	3.75	0.56	1.38	1.50	1.75	3.75	4	0.62	2.62	1.75	1.50	0.75	1/2	3	3	5	0.4	7	0.6	24	3.1	9
3/4	0.75	0.74	4.62	0.62	1.69	1.88	2.19	4.62	4	0.75	3.25	2.19	1.88	0.88	5/8	3 1/2	3 1/2	8	0.7	11	0.9	37	4.6	9
1	1.00	0.96	4.88	0.69	2.00	2.12	2.44	4.88	4	0.75	3.50	2.44	2.12	0.88	5/8	3 1/2	3 1/2	9	0.8	12	1.1	40	5.1	9
1 1/4	1.25	1.28	5.25	0.81	2.50	2.50	2.81	5.25	4	0.75	3.88	2.81	2.50	0.88	5/8	3 3/4	3 3/4	13	1	15	1.4	45	5.8	9
1 1/2	1.50	1.50	6.12	0.88	2.88	2.75	3.25	6.12	4	0.88	4.50	3.25	2.75	1.00	3/4	4 1/4	4 1/4	16	1.2	21	1.9	61	7.8	9
2	2.00	1.94	6.50	1.00	3.62	3.31	3.94	6.50	8	0.75	5.00	3.94	3.31	0.88	5/8	4 1/4	4 1/4	20	1.5	29	2.6	68	8.5	9
2 1/2	2.50	2.32	7.50	1.12	4.12	3.94	4.63	7.50	8	0.88	5.88	4.63	3.94	1.00	3/4	4 3/4	4 3/4	27	2.1	39	3.6	88	11	9
3	3.00	2.90	8.25	1.25	5.00	4.62	5.38	8.25	8	0.88	6.62	5.38	4.62	1.00	3/4	5	5	36	2.7	50	4.6	104	13	9
3 1/2	3.50	3.36	9.00	1.38	5.50	5.25	5.81	9.00	8	1.00	7.25	5.81	5.25	1.12	7/8	5 1/2	5 1/2	45	3.4	61	5.5	116	15	9
4	4.00	3.83	10.00	1.38	6.19	5.75	6.44	10.00	8	1.00	7.88	6.44	5.75	1.12	7/8	5 1/2	5 1/2	65	3.8	93	6.5	197	19	12
5	5.00	4.81	11.00	1.50	7.31	7.00	7.81	11.00	8	1.00	9.25	7.81	7.00	1.12	7/8	5 3/4	5 3/4	88	5.3	127	9.1	229	22	12
6	6.00	5.76	12.50	1.62	8.50	8.12	9.19	12.50	12	1.00	10.62	9.19	8.12	1.12	7/8	6	6	110	6.7	169	12	286	27	12
8	8.00	7.62	15.00	1.88	10.62	10.25	11.38	15.00	12	1.12	13.00	11.38	10.25	1.25	1	6 3/4	6 3/4	154	9.1	233	17	379	36	12
10	10.00	9.56	17.50	2.12	12.75	12.62	13.44	17.50	16	1.25	15.25	13.44	12.62	1.38	1 1/8	7 1/2	7 1/2	218	13	298	21	475	46	12
12	12.00	11.38	20.50	2.25	15.00	14.75	15.75	20.50	16	1.38	17.75	15.75	14.75	1.50	1 1/4	8	8	285	16	401	28	627	62	12
14	14.00	14.00	23.00	2.38	16.25	16.75	18.25	23.00	20	1.38	20.25	18.25	16.75	1.50	1 1/4	8 1/4	8 1/4	336	19	467	32	758	74	12
16	16.00	16.00	25.50	2.50	18.50	19.00	20.31	25.50	20	1.50	22.50	20.31	19.00	1.62	1 3/8	8 3/4	8 3/4	418	23	542	37	884	88	12
18	18.00	18.00	28.00	2.62	21.00	21.00	22.56	28.00	24	1.50	24.75	22.56	21.00	1.62	1 3/8	9	9	482	26	645	43	1033	102	12
20	20.00	20.00	30.50	2.75	23.00	23.12	24.63	30.50	24	1.62	27.00	24.63	23.12	1.75	1 1/2	9 1/2	9 3/4	568	30	759	50	1165	118	12
24	24.00	24.00	36.00	3.00	27.25	27.62	29.25	36.00	24	1.88	32.00	29.25	27.62	2.00	1 3/4	10 1/2	11	804	42	1040	67	1540	160	12

Dimensions are in inches. Weights are in pounds.

Class 600 - Long Weld Neck

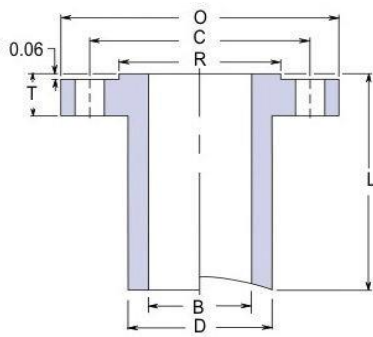

LONG WELD NECK "LWN"

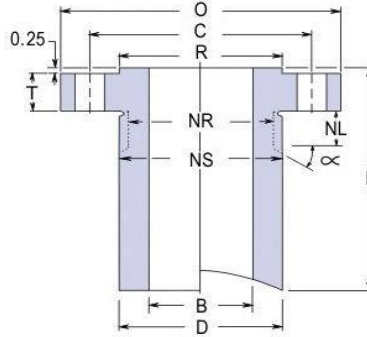

HEAVY BARREL "HB"

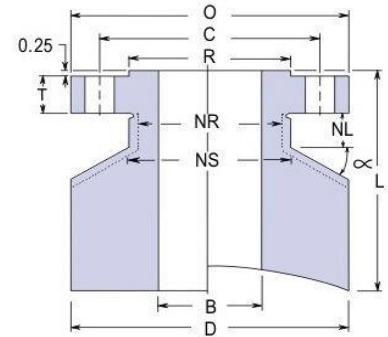

EQUAL BARREL "E"

Nom	Size		Flange			Barrel OD			Bolting			Nut			Stud Bolt			Weights						Length
	Bore LWN & E	Bore HB	OD	Thk	RF of OD	LWN	HB	E	# of Holes	Hole Size	Bolt Circle	Stop Dia	Relief Dia	Relief Length	Size	RF Length	RTJ Length	LWN		HB		E		Base
	B	B	O	T	R	D	D	D		C	NS	NR	NL				Base	Per 1"	Base	Per 1"	Base	Per 1"	Base	L
1/2	0.50	0.55	3.75	0.56	1.38	1.50	1.75	3.75	4	0.62	2.62	1.75	1.50	0.75	1/2	3	3	5	0.4	7	0.6	24	3.1	9
3/4	0.75	0.74	4.62	0.62	1.69	1.88	2.19	4.62	4	0.75	3.25	2.19	1.88	0.88	5/8	3 1/2	3 1/2	8	0.7	11	0.9	36	4.6	9
1	1.00	0.96	4.88	0.69	2.00	2.12	2.44	4.88	4	0.75	3.50	2.44	2.12	0.88	5/8	3 1/2	3 1/2	9	0.8	12	1.1	39	5.1	9
1 1/4	1.25	1.28	5.25	0.81	2.50	2.50	2.81	5.25	4	0.75	3.88	2.81	2.50	0.88	5/8	3 3/4	3 3/4	13	1	15	1.4	44	5.8	9
1 1/2	1.50	1.50	6.12	0.88	2.88	2.75	3.25	6.12	4	0.88	4.50	3.25	2.75	1.00	3/4	4 1/4	4 1/4	16	1.2	21	1.9	59	7.8	9
2	2.00	1.94	6.50	1.00	3.62	3.31	3.94	6.50	8	0.75	5.00	3.94	3.31	0.88	5/8	4 1/4	4 1/4	20	1.5	29	2.6	67	8.5	9
2 1/2	2.50	2.32	7.50	1.12	4.12	3.94	4.62	7.50	8	0.88	5.88	4.62	3.94	1.00	3/4	5	4 3/4	27	2.1	39	3.6	85	11	9
3	3.00	2.90	8.25	1.25	5.00	4.62	5.38	8.25	8	0.88	6.62	5.38	4.62	1.00	3/4	5	5 1/4	36	2.7	50	4.6	104	13	9
3 1/2	3.50	3.36	9.00	1.38	5.50	5.25	5.81	9.00	8	1.00	7.25	5.81	5.25	1.12	7/8	5 1/2	5 1/2	45	3.4	57	5	116	15	9
4	4.00	3.83	10.75	1.50	6.19	6.00	7.06	10.75	8	1.00	8.50	7.06	6.00	1.12	7/8	5 3/4	6	77	4.5	113	7.8	238	22	12
5	5.00	4.81	13.00	1.75	7.31	7.50	8.88	13.00	8	1.12	10.50	8.88	7.50	1.25	1	6 1/2	6 1/2	123	7	180	12	336	32	12
6	6.00	5.76	14.00	1.88	8.50	8.75	9.88	14.00	12	1.12	11.50	9.88	8.75	1.25	1	6 3/4	7	152	9	207	14	373	36	12
8	8.00	7.62	16.50	2.19	10.62	10.75	11.94	16.50	12	1.25	13.75	11.94	10.75	1.38	1 1/8	7 3/4	8	207	11	277	19	478	46	12
10	10.00	9.56	20.00	2.50	12.75	13.50	15.00	20.00	16	1.38	17.00	15.00	13.50	1.50	1 1/4	8 1/2	8 3/4	324	18	433	30	683	67	12
12	12.00	11.38	22.00	2.62	15.00	15.75	17.25	22.00	20	1.38	19.25	17.25	15.75	1.50	1 1/4	8 3/4	9	393	23	533	37	779	76	12
14	14.00	14.00	23.75	2.75	16.25	17.00	18.56	23.75	20	1.50	20.75	18.56	17.00	1.62	1 3/8	9 1/4	9 1/2	471	21	631	33	1149	82	16
16	16.00	16.00	27.00	3.00	18.50	19.50	21.38	27.00	20	1.62	23.75	21.38	19.50	1.75	1 1/2	10	10 1/4	638	28	856	45	1471	105	16
18	18.00	18.00	29.25	3.25	21.00	21.50	23.19	29.25	20	1.75	25.75	23.19	21.50	1.88	1 5/8	10 3/4	11	731	31	941	48	1628	118	16
20	20.00	20.00	32.00	3.50	23.00	24.00	25.94	32.00	24	1.75	28.50	25.94	24.00	1.88	1 5/8	11 1/2	11 3/4	916	39	1180	61	1920	139	16
24	24.00	24.00	37.00	4.00	27.25	28.25	30.06	37.00	24	2.00	33.00	30.06	28.25	2.12	1 7/8	13	13 1/2	1210	49	1486	73	2376	176	16

Dimensions are in inches. Weights are in pounds.

Class 900 - Long Weld Neck

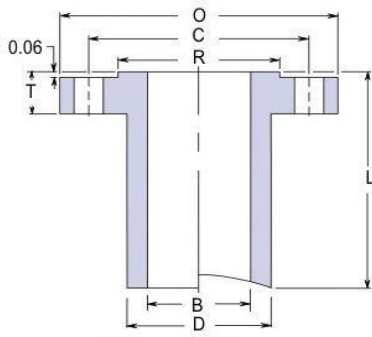

LONG WELD NECK "LWN"

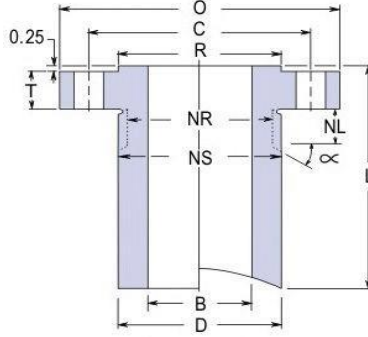

HEAVY BARREL "HB"

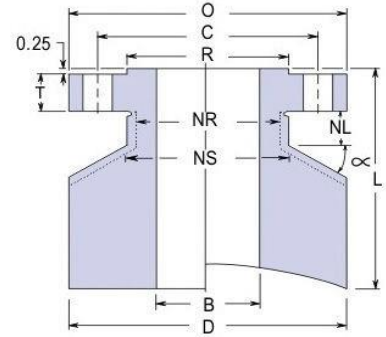

EQUAL BARREL "E"

Nom	Size		Flange			Barrel OD			Bolting			Nut			Stud Bolt			Weights					Length	
	Bore LWN & E	Bore HB	OD	Thk	RF of OD	LWN	HB	E	# of Holes	Hole Size	Bolt Circle	Stop Dia	Relief Dia	Relief Length	Size	RF Length	RTJ Length	LWN	HB		E		Base	
	B	B	O	T	R	D	D	D		C	NS	NR	NL				Base	Per 1"	Base	Per 1"	Base	Per 1"	L	
1/2	0.50	0.55	4.75	0.88	1.38	1.56	2.00	4.75	4	0.88	3.25	2.00	1.56	1.00	3/4	4 1/4	4 1/4	8	0.5	10	0.8	37	5	9
3/4	0.75	0.74	5.12	1.00	1.69	1.81	2.25	5.12	4	0.88	3.50	2.25	1.81	1.00	3/4	4 1/2	4 1/2	10	0.6	13	1	42	5.7	9
1	1.00	0.96	5.88	1.12	2.00	2.12	2.56	5.88	4	1.00	4.00	2.56	2.12	1.12	7/8	5	5	13	0.8	17	1.3	54	7.5	9
1 1/4	1.25	1.28	6.25	1.12	2.50	2.50	2.94	6.25	4	1.00	4.38	2.94	2.50	1.12	7/8	5	5	17	1	20	1.6	61	8.3	9
1 1/2	1.50	1.50	7.00	1.25	2.88	2.75	3.25	7.00	4	1.12	4.88	3.25	2.75	1.25	1	5 1/2	5 1/2	21	1.2	26	1.9	77	10	9
2	2.00	1.94	8.50	1.50	3.62	4.12	5.06	8.50	8	1.00	6.50	5.06	4.12	1.12	7/8	5 3/4	5 3/4	42	2.9	56	4.9	115	15	9
2 1/2	2.50	2.32	9.62	1.62	4.12	4.88	5.88	9.62	8	1.12	7.50	5.88	4.88	1.25	1	6 1/4	6 1/4	56	3.9	75	6.5	144	19	9
3	3.00	2.90	9.50	1.50	5.00	5.00	6.06	9.50	8	1.00	7.50	6.06	5.00	1.12	7/8	5 3/4	5 3/4	51	3.6	71	6.3	139	18	9
4	4.00	3.83	11.50	1.75	6.19	6.25	7.44	11.50	8	1.25	9.25	7.44	6.25	1.38	1 1/8	6 3/4	6 3/4	93	5.1	133	9.1	270	26	12
5	5.00	4.81	13.75	2.00	7.31	7.50	9.00	13.75	8	1.38	11.00	9.00	7.50	1.50	1 1/4	7 1/2	7 1/2	135	7	194	13	376	37	12
6	6.00	5.76	15.00	2.19	8.50	9.25	10.69	15.00	12	1.25	12.50	10.69	9.25	1.38	1 1/8	7 1/2	7 3/4	191	11	259	18	436	42	12
8	8.00	7.62	18.50	2.50	10.62	11.75	13.31	18.50	12	1.50	15.50	13.31	11.75	1.62	1 3/8	8 3/4	8 3/4	297	16	389	27	626	62	12
10	10.00	9.56	21.50	2.75	12.75	14.50	16.31	21.50	16	1.50	18.50	16.31	14.50	1.62	1 3/8	9 1/4	9 1/4	422	25	558	39	824	81	12
12	12.00	11.38	24.00	3.12	15.00	16.50	18.81	24.00	20	1.50	21.00	18.81	16.50	1.62	1 3/8	10	10	518	29	715	50	984	96	12
14	14.00	14.00	25.25	3.38	16.25	17.75	19.62	25.25	20	1.62	22.00	19.62	17.75	1.75	1 1/2	10 3/4	11	624	26	817	42	1368	98	16
16	16.00	16.00	27.75	3.50	18.50	20.00	21.69	27.75	20	1.75	24.25	21.69	20.00	1.88	1 5/8	11 1/4	11 1/2	750	32	942	48	1573	114	16
18	18.00	18.00	31.00	4.00	21.00	22.25	24.06	31.00	20	2.00	27.00	24.06	22.25	2.12	1 7/8	12 3/4	13 1/4	950	38	1169	57	1898	142	16
20	20.00	20.00	33.75	4.25	23.00	24.50	26.38	33.75	20	2.12	29.50	26.38	24.50	2.25	2	13 3/4	14 1/4	1121	43	1378	66	2182	164	16
24	24.00	24.00	41.00	5.50	27.25	29.50	31.62	41.00	20	2.62	35.50	31.62	29.50	2.75	2 1/2	17 1/4	18	1865	65	2160	94	3084	246	16

Dimensions are in inches. Weights are in pounds.

Class 1500 - Long Weld Neck

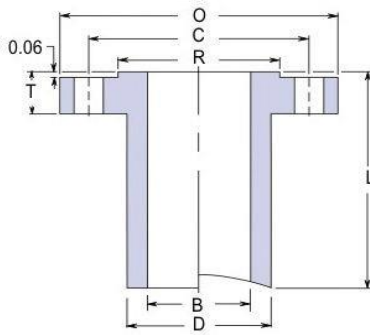

LONG WELD NECK "LWN"

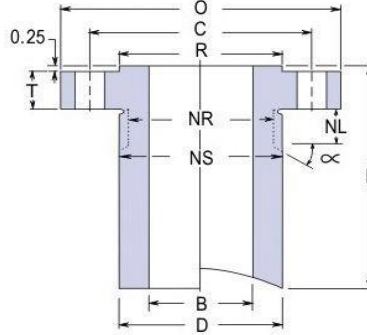

HEAVY BARREL "HB"

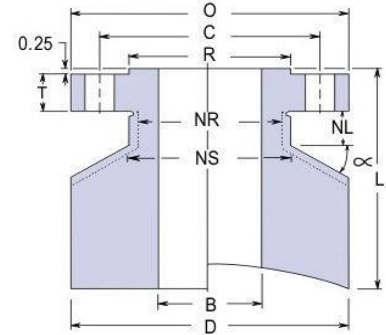

EQUAL BARREL "E"

Nom	Size		Flange			Barrel OD			Bolting			Nut			Stud Bolt			Weights					Length	
	Bore LWN & E	Bore HB	OD	Thk	RF of OD	LWN	HB	E	# of Holes	Hole Size	Bolt Circle	Stop Dia	Relief Dia	Relief Length	Size	RF Length	RTJ Length	LWN	HB		E		Base	
	B	B	O	T	R	D	D	D		C	NS	NR	NL				Base	Per 1"	Base	Per 1"	Base	Per 1"	L	
1/2	0.50	0.55	4.75	0.88	1.38	1.56	2.00	4.75	4	0.88	3.25	2.00	1.56	1.00	3/4	4 1/4	4 1/4	8	0.5	10	0.8	37	5	9
3/4	0.75	0.74	5.12	1.00	1.69	1.81	2.25	5.12	4	0.88	3.50	2.25	1.81	1.00	3/4	4 1/2	4 1/2	10	0.6	13	1	42	5.7	9
1	1.00	0.96	5.88	1.12	2.00	2.12	2.56	5.88	4	1.00	4.00	2.56	2.12	1.12	7/8	5	5	13	0.8	17	1.3	54	7.5	9
1 1/4	1.25	1.28	6.25	1.12	2.50	2.50	2.94	6.25	4	1.00	4.38	2.94	2.50	1.12	7/8	5	5	17	1	20	1.6	61	8.3	9
1 1/2	1.50	1.50	7.00	1.25	2.88	2.75	3.25	7.00	4	1.12	4.88	3.25	2.75	1.25	1	5 1/2	5 1/2	21	1.2	26	1.9	77	10	9
2	2.00	1.94	8.50	1.50	3.62	4.12	5.06	8.50	8	1.00	6.50	5.06	4.12	1.12	7/8	5 3/4	5 3/4	42	2.9	56	4.9	115	15	9
2 1/2	2.50	2.32	9.62	1.62	4.12	4.88	5.88	9.62	8	1.12	7.50	5.88	4.88	1.25	1	6 1/4	6 1/4	56	3.9	75	6.5	144	19	9
3	3.00	2.90	10.50	1.88	5.00	5.25	6.19	10.50	8	1.25	8.00	6.19	5.25	1.38	1 1/8	7	7	67	4.1	84	6.7	161	23	9
4	4.00	3.83	12.25	2.12	6.19	6.38	7.50	12.25	8	1.38	9.50	7.50	6.38	1.50	1 1/4	7 3/4	7 3/4	110	5.5	147	9.3	302	30	12
5	5.00	4.81	14.75	2.88	7.31	7.75	9.12	14.75	8	1.62	11.50	9.12	7.75	1.75	1 1/2	9 3/4	9 3/4	181	7.8	233	13	414	43	12
6	6.00	5.76	15.50	3.25	8.50	9.00	10.31	15.50	12	1.50	12.50	10.31	9.00	1.62	1 3/8	10 1/4	10 1/2	215	10	272	16	445	46	12
8	8.00	7.62	19.00	3.62	10.62	11.50	12.94	19.00	12	1.75	15.50	12.94	11.50	1.88	1 5/8	11 1/2	12 3/4	337	15	417	24	629	67	12
10	10.00	9.56	23.00	4.25	12.75	14.50	16.06	23.00	12	2.00	19.00	16.06	14.50	2.12	1 7/8	13 1/4	13 1/2	546	25	651	37	888	97	12
12	12.00	11.38	26.50	4.88	15.00	17.75	19.38	26.50	16	2.12	22.50	19.38	17.75	2.25	2	14 3/4	15 1/4	946	38	1148	55	1683	127	16
14	14.00	14.00	29.50	5.25	16.25	19.50	21.50	29.50	16	2.38	25.00	21.50	19.50	2.50	2 1/4	16	16 3/4	1116	41	1308	59	1929	150	16
16	16.00	16.00	32.50	5.75	18.50	21.75	23.88	32.50	16	2.62	27.75	23.88	21.75	2.75	2 1/2	17 1/2	18 1/2	1371	48	1588	70	2238	178	16
18	18.00	18.00	36.00	6.38	21.00	23.50	26.25	36.00	16	2.88	30.50	26.25	23.50	3.00	2 3/4	19 1/2	20 3/4	1674	51	1959	81	2629	216	16
20	20.00	20.00	38.75	7.00	23.00	25.25	28.12	38.75	16	3.12	32.75	28.12	25.25	3.25	3	21 1/4	22 1/4	1943	53	2241	87	2868	245	16
24	24.00	24.00	46.00	8.00	27.25	30.00	33.62	46.00	16	3.62	39.00	33.62	30.00	3.75	3 1/2	24 1/4	25 1/2	2936	72	3334	123	3819	343	16

Dimensions are in inches. Weights are in pounds.

Class 2500 - Long Weld Neck

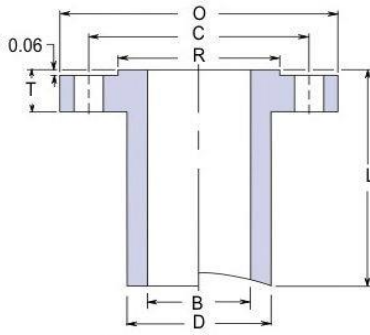

LONG WELD NECK "LWN"

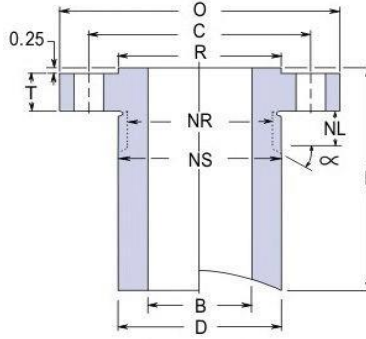

HEAVY BARREL "HB"

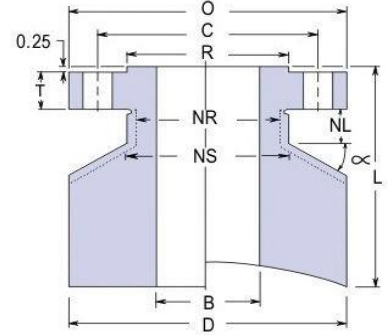

EQUAL BARREL "E"

Nom	Size		Flange			Barrel OD			Bolting			Nut			Stud Bolt			Weights						Length
	Bore LWN & E	Bore HB	OD	Thk	RF of OD	LWN	HB	E	# of Holes	Hole Size	Bolt Circle	Stop Dia	Relief Dia	Relief Length	Size	RF Length	RTJ Length	LWN	HB		E		Base	
	B	B	O	T	R	D	D	D		C	NS	NR	NL				Base	Per 1"	Base	Per 1"	Base	Per 1"	L	
1/2	0.50	0.55	5.25	1.19	1.38	1.81	2.25	5.25	4	0.88	3.50	2.25	1.81	1.00	3/4	4 3/4	4 3/4	11	0.7	14	1.1	45	6.1	9
3/4	0.75	0.74	5.50	1.25	1.69	2.06	2.50	5.50	4	0.88	3.75	2.50	2.06	1.00	3/4	5	5	13	0.8	17	1.3	49	6.6	9
1	1.00	0.96	6.25	1.38	2.00	2.25	2.81	6.25	4	1.00	4.25	2.81	2.25	1.12	7/8	5 1/2	5 1/2	18	0.9	22	1.6	62	8.5	9
1 1/4	1.25	1.28	7.25	1.50	2.50	2.88	3.50	7.25	4	1.12	5.12	3.50	2.88	1.25	1	6	6	27	1.5	32	2.4	84	11	9
1 1/2	1.50	1.50	8.00	1.75	2.88	3.12	3.94	8.00	4	1.25	5.75	3.94	3.12	1.38	1 1/8	6 3/4	6 3/4	33	1.7	42	3	94	14	9
2	2.00	1.94	9.25	2.00	3.62	3.75	5.12	9.25	8	1.12	6.75	5.12	3.75	1.25	1	7	7	48	2.2	66	5	131	18	9
2 1/2	2.50	2.32	10.50	2.25	4.12	4.50	5.94	10.50	8	1.25	7.75	5.94	4.50	1.38	1 1/8	7 3/4	8	66	3.1	90	6.7	165	23	9
3	3.00	2.90	12.00	2.62	5.00	5.25	7.00	12.00	8	1.38	9.00	7.00	5.25	1.50	1 1/4	8 3/4	9	97	4.1	127	9	210	30	9
4	4.00	3.83	14.00	3.00	6.19	6.50	8.38	14.00	8	1.62	10.75	8.38	6.50	1.75	1 1/2	10	10 1/4	159	5.8	218	12	391	40	12
5	5.00	4.81	16.50	3.62	7.31	8.00	10.00	16.50	8	1.88	12.75	10.00	8.00	2.00	1 3/4	11 3/4	12 1/4	248	8.7	319	17	518	55	12
6	6.00	5.76	19.00	4.25	8.50	9.25	11.38	19.00	8	2.12	14.50	11.38	9.25	2.25	2	13 1/2	14	358	11	441	21	641	73	12
8	8.00	7.62	21.75	5.00	10.62	12.00	14.12	21.75	12	2.12	17.25	14.12	12.00	2.25	2	15	15 1/2	589	18	743	31	1167	92	16
10	10.00	9.56	26.50	6.50	12.75	14.75	17.38	26.50	12	2.62	21.25	17.38	14.75	2.75	2 1/2	19 1/4	20	997	26	1202	47	1625	134	16
12	12.00	11.38	30.00	7.25	15.00	17.38	20.12	30.00	12	2.88	24.38	20.12	17.38	3.00	2 3/4	21 1/4	22	1363	35	1609	61	1995	168	16

Dimensions are in inches. Weights are in pounds.

Class 150 Studding Outlets

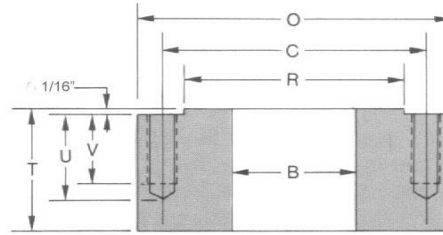

Flat Bottom

Bore B	OD O	Thickness T	OD of RF R	Stud Circle C	Hole Dia	# of Holes	Hole Depth U	Tap Size	Tap Depth V	Flat Bottom Weight	
										Base	per 1"
1/2	3.50	1.25	1.38	2.38	27/64	4	0.88	1/2	0.56	3	2.7
3/4	3.88	1.25	1.69	2.75	27/64	4	0.88	1/2	0.56	3.7	3.2
1	4.25	1.25	2.00	3.12	27/64	4	0.88	1/2	0.56	4.3	3.8
1 1/4	4.62	1.25	2.50	3.50	27/64	4	0.88	1/2	0.56	5.1	4.4
1 1/2	5.00	1.25	2.88	3.88	27/64	4	1.12	1/2	0.56	5.9	5.1
2	6.00	1.50	3.62	4.75	17/32	4	1.12	5/8	0.75	10.2	7.1
2 1/2	7.00	1.50	4.12	5.50	17/32	4	1.12	5/8	0.75	14	9.5
3	7.50	1.50	5.00	6.00	17/32	4	1.12	5/8	0.75	15	11
3 1/2	8.50	1.50	5.50	7.00	17/32	8	1.12	5/8	0.75	19	13
4	9.00	1.50	6.19	7.50	17/32	8	1.31	5/8	0.75	20	14
5	10.00	1.75	7.31	8.50	21/32	8	1.31	3/4	0.88	28	17
6	11.00	1.75	8.53	9.50	21/32	8	1.31	3/4	0.88	31	19
8	13.50	1.75	10.62	11.75	21/32	8	1.31	3/4	0.88	46	26
10	16.00	1.81	12.75	14.25	49/64	12	1.44	7/8	1.00	58	35
12	19.00	1.81	15.00	17.00	49/64	12	1.44	7/8	1.00	83	48
14	21.00	2.00	16.25	18.75	7/8	12	1.56	1	1.12	102	55
16	23.50	2.00	18.50	21.25	7/8	16	1.56	1	1.12	123	66
18	25.00	2.25	21.00	22.75	1	16	1.81	1 1/8	1.25	140	67
20	27.50	2.25	23.00	25.00	1	20	1.81	1 1/8	1.25	166	79
24	32.00	2.50	27.25	29.50	1 1/8	20	2.12	1 1/4	1.44	231	100

Dimensions are in inches. Weights are in pounds.

Material: Studding Outlets are most commonly provided in SA-105. They can also be made from a full range of stainless and alloy materials.

Thickness: The standard thickness shown above for all studding outlets is the minimum required per ASME Section VIII Division I Paragraph UG-43(d) for thread engagement and an ID mount. It is important to note that each individual application should be analyzed for proper thickness.

Facing: The Studding Outlet minimum thickness "T" includes proper raised face per ANSI B16.5. Outlets can be supplied with any special facing as needed upon request.

Drilling and Tapping: Studding Outlets are furnished to ANSI B16.5 specifications unless otherwise specified. Thread depth is in accordance with ASME Section VIII Division I Para. UG-43(g) for a design temperature not to exceed 650°F, a base metal stress of 17,500 psi (g), and a stud stress of 25,000 psi (g). All other materials exceeding these stresses should be checked for UG-43 compliance.

Bore: Bore sizes shown above are standard. Other sizes can be furnished upon request.

Class 300 Studding Outlets

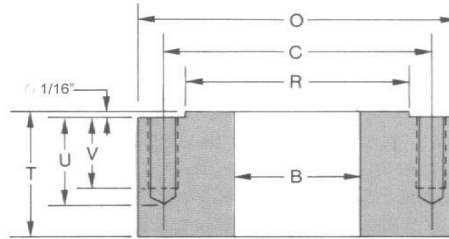

Flat Bottom

Bore	OD	Thickness	OD of RF	Stud Circle	Hole Dia	# of Holes	Hole Depth	Tap Size	Tap Depth	Flat Bottom Weight	
										Base	per 1"
B	O	T	R	C			U		V		
1/2	3.75	1.25	1.38	2.62	27/64	4	0.88	1/2	0.56	3.5	3.1
3/4	4.62	1.50	1.69	3.25	17/32	4	1.12	5/8	0.75	6.4	4.6
1	4.88	1.50	2.00	3.50	17/32	4	1.12	5/8	0.75	7	5.1
1 1/4	5.25	1.50	2.50	3.88	17/32	4	1.12	5/8	0.75	8	5.8
1 1/2	6.12	1.75	2.88	4.50	21/32	4	1.31	3/4	0.88	13	7.8
2	6.50	1.50	3.62	5.00	17/32	8	1.12	3/4	0.75	12	8.5
2 1/2	7.50	1.75	4.12	5.88	21/32	8	1.31	3/4	0.88	18	11
3	8.25	1.75	5.00	6.62	21/32	8	1.31	3/4	0.88	22	14
3 1/2	9.00	1.75	5.50	7.25	21/32	8	1.31	3/4	0.88	25	15
4	10.00	1.75	6.19	7.88	21/32	8	1.31	3/4	0.88	30	19
5	11.00	1.75	7.31	9.25	21/32	8	1.31	3/4	0.88	36	21
6	12.50	1.75	8.50	10.62	21/32	12	1.31	3/4	0.88	44	27
8	15.00	1.88	10.62	13.33	49/64	12	1.44	7/8	1.00	63	36
10	17.50	2.12	12.75	15.25	7/8	16	1.56	1	1.12	90	46
12	20.50	2.25	15.00	17.75	1	16	1.81	1 1/8	1.25	127	61
14	23.00	2.25	16.25	20.25	1	20	1.81	1 1/8	1.25	153	74
16	25.50	2.50	18.50	22.50	1 1/8	220	2.12	1 1/4	1.44	201	88
18	28.00	2.50	21.00	24.75	1 1/8	24	2.12	1 1/4	1.44	235	102
20	30.50	2.50	23.00	27.00	1 1/8	24	2.12	1 1/4	1.44	273	118
24	36.00	2.88	27.25	32.00	1 3/8	24	2.38	1 1/2	1.69	425	160

Dimensions are in inches. Weights are in pounds.

Material: Studding Outlets are most commonly provided in SA-105. They can also be made from a full range of stainless and alloy materials.

Thickness: The standard thickness shown above for all studding outlets is the minimum required per ASME Section VIII Division I Paragraph UG-43(d) for thread engagement and an ID mount. It is important to note that each individual application should be analyzed for proper thickness.

Facing: The Studding Outlet minimum thickness "T" includes proper raised face per ANSIB16.5. Outlets can be supplied with any special facing as needed upon request.

Drilling and Tapping: Studding Outlets are furnished to ANSIB16.5 specifications unless otherwise specified. Thread depth is in accordance with ASME Section VIII Division I Para. UG-43(g) for a design temperature not to exceed 650°F, a base metal stress of 17,500 psi (g), and a stud stress of 25,000 psi (g). All other materials exceeding these stresses should be checked for UG-43 compliance.

Bore: Bore sizes shown above are standard. Other sizes can be furnished upon request.

Curving: All connections can be furnished contoured to fit any shell, head, or cone at an additional cost. Specify diameter to be mounted.

Class 600 Studding Outlets

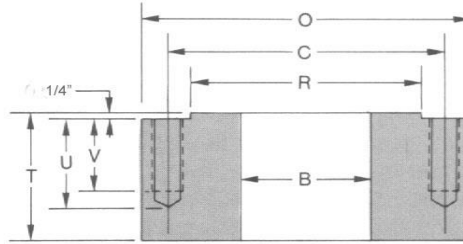

Flat Bottom

Bore	OD	Thickness	OD of RF	Stud Circle	Hole Dia	# of Holes	Hole Depth	Tap Size	Tap Depth	Flat Bottom Weight	
B	O	T	R	C			U		V	Base	per 1"
1/2	3.75	1.50	1.38	2.62	27/64	4	0.88	1/2	0.56	3.8	3.1
3/4	4.62	1.75	1.69	3.25	17/32	4	1.12	5/8	0.75	6.7	4.6
1	4.88	1.75	2.00	3.50	17/32	4	1.12	5/8	0.75	7.4	5.1
1 1/4	5.25	1.75	2.50	3.88	17/32	4	1.12	5/8	0.75	8.6	5.8
1 1/2	6.12	1.94	2.88	4.50	21/32	4	1.31	3/4	0.88	13	7.8
2	6.50	1.75	3.62	5.00	17/32	8	1.12	5/8	0.75	12	8.5
2 1/2	7.50	2.00	4.12	5.88	21/32	8	1.31	3/4	0.88	19	11
3	8.25	2.00	5.00	6.62	21/32	8	1.31	3/4	0.88	23	13
3 1/2	9.00	2.12	5.50	7.25	49/64	8	1.44	7/8	1.00	28	15
4	10.75	2.12	6.19	8.50	49/64	8	1.44	7/8	1.00	41	22
5	13.00	2.25	7.31	10.50	7/8	8	1.56	1	1.12	63	31
6	14.00	2.25	8.50	11.50	7/8	12	1.56	1	1.12	68	36
8	16.50	2.50	10.62	13.75	1	12	1.81	1 1/8	1.25	101	46
10	20.00	2.75	12.75	17.00	1 1/8	16	2.12	1 1/4	1.44	160	67
12	22.00	2.75	15.00	19.25	1 1/8	20	2.12	1 1/4	1.44	180	76
14	23.75	2.88	16.25	20.75	1 1/4	20	2.25	1 3/8	1.56	201	82
16	27.00	3.00	18.50	23.75	1 3/8	20	2.38	1 1/2	1.69	271	105
18	29.25	3.25	21.00	25.75	1 1/2	20	2.56	1 5/8	1.88	331	118
20	32.00	3.25	23.00	28.50	1 1/2	24	2.56	1 5/8	1.88	387	139
24	37.00	3.75	27.25	33.00	1 3/4	24	3.00	1 7/8	2.12	571	176

Dimensions are in inches. Weights are in pounds.

Material: Studding Outlets are most commonly provided in SA-105. They can also be made from a full range of stainless and alloy materials.

Thickness: The standard thickness shown above for all studding outlets is the minimum required per ASME Section VIII Division I Paragraph UG-43(d) for thread engagement and an ID mount. It is important to note that each individual application should be analyzed for proper thickness.

Facing: The Studding Outlet minimum thickness "T" includes proper raised face per ANSI B16.5. Outlets can be supplied with any special facing as needed upon request.

Drilling and Tapping: Studding Outlets are furnished to ANSI B16.5 specifications unless otherwise specified. Thread depth is in accordance with ASME Section VIII Division I Para. UG-43(g) for a design temperature not to exceed 650°F, a base metal stress of 17,500 psi (g), and a stud stress of 25,000 psi (g). All other materials exceeding these stresses should be checked for UG-43 compliance.

Bore: Bore sizes shown above are standard. Other sizes can be furnished upon request.

Curving: All connections can be furnished contoured to fit any shell, head, or cone at an additional cost. Specify diameter to be mounted.

Class 900 Studding Outlets

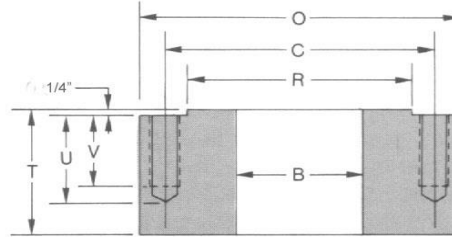

Flat Bottom

Bore	OD	Thickness	OD of RF	Stud Circle	Hole Dia	# of Holes	Hole Depth	Tap Size	Tap Depth	Flat Bottom Weight	
B	O	T	R	C			U		V	Base	per 1"
1/2	4.75	2.00	1.38	3.25	21/32	4	1.31	3/4	0.88	8.2	5
3/4	5.12	2.00	1.69	3.50	21/32	4	1.31	3/4	0.88	10	5.7
1	5.88	2.12	2.00	4.00	49/64	4	1.44	7/8	1.00	14	7.5
1 1/4	6.25	2.12	2.50	4.38	49/64	4	1.44	7/8	1.00	15	8.3
1 1/2	7.00	2.25	2.88	4.88	7/8	4	1.56	1	1.12	20	10
2	8.50	2.12	3.62	6.50	49/64	8	1.44	7/8	1.00	27	15
2 1/2	9.62	2.25	4.12	7.50	7/8	8	1.56	1	1.12	37	19
3	9.50	2.12	5.00	7.50	49/64	8	1.44	7/8	1.00	33	18
4	11.50	2.50	6.19	9.25	1	8	1.81	1 1/8	1.25	56	26
5	13.75	2.75	7.31	11.00	1 1/8	8	2.12	1 1/4	1.44	87	37
6	15.00	2.50	8.50	12.50	1	12	1.81	1 1/8	1.25	91	42
8	18.50	3.00	10.62	15.50	1 1/4	12	2.25	1 3/8	1.56	162	62
10	21.50	3.00	12.75	18.50	1 1/4	16	2.25	1 3/8	1.56	210	81
12	24.00	3.00	15.00	21.00	1 1/4	20	2.25	1 3/8	1.56	251	96
14	25.25	3.25	16.25	22.00	1 3/8	20	2.38	1 1/2	1.69	275	98
16	27.75	3.50	18.50	24.25	1 1/2	20	2.56	1 5/8	1.88	348	114
18	31.00	3.88	21.00	27.00	1 3/4	20	3.00	1 7/8	2.12	473	142
20	33.75	4.25	23.00	29.50	1 7/8	20	3.31	2	2.25	608	164
24	41.00	5.12	27.25	35.50	2 3/8	20	4.00	2 1/2	2.81	1096	246

Dimensions are in inches. Weights are in pounds.

Material: Studding Outlets are most commonly provided in SA-105. They can also be made from a full range of stainless and alloy materials.

Thickness: The standard thickness shown above for all studding outlets is the minimum required per ASME Section VIII Division I Paragraph UG-43(d) for thread engagement and an ID mount. It is important to note that each individual application should be analyzed for proper thickness.

Facing: The Studding Outlet minimum thickness "T" includes proper raised face per ANSI B16.5. Outlets can be supplied with any special facing as needed upon request.

Drilling and Tapping: Studding Outlets are furnished to ANSI B16.5 specifications unless otherwise specified. Thread depth is in accordance with ASME Section VIII Division I Para. UG-43(g) for a design temperature not to exceed 650°F, a base metal stress of 17,500 psi (g), and a stud stress of 25,000 psi (g). All other materials exceeding these stresses should be checked for UG-43 compliance.

Bore: Bore sizes shown above are standard. Other sizes can be furnished upon request.

Curving: All connections can be furnished contoured to fit any shell, head, or cone at an additional cost. Specify diameter to be mounted.

Class 1500 Studding Outlets

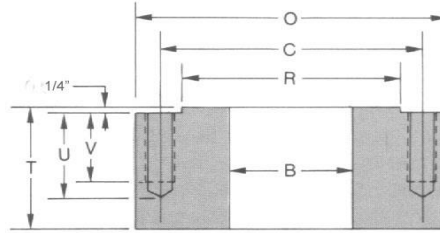

Flat Bottom

Bore Size	OD	Thickness	OD of RF	Stud Circle	Stud Length	Hole Dia	# of Holes	Hole Depth	Tap Size	T.P.I.	Tap Depth	Flat Bottom Weight	
												Base	per 1"
B	O	T	R	C				U			V		
1/2	4.75	2.00	1.38	3.25	4.25	21/32	4	1.31	3/4	10	0.88	8.2	5
3/4	5.12	2.00	1.69	3.5	4.38	21/32	4	1.31	3/4	10	0.88	10	5.7
1	5.88	2.12	2.00	4.00	4.88	49/64	4	1.44	7/8	9	1.00	14	7.5
1 1/4	6.25	2.12	2.50	4.38	4.88	49/64	4	1.44	7/8	9	1.00	15	8.3
1 1/2	7.00	2.25	2.88	4.88	5.38	7/8	4	1.56	1	8	1.12	20	10
2	8.50	2.12	3.62	6.50	5.25	49/64	8	1.44	7/8	9	1.00	27	15
2 1/2	9.62	2.25	4.12	7.50	5.75	7/8	8	1.56	1	8	1.12	3	19
3	10.50	2.50	5.00	8.00	6.38	1	8	1.81	1 1/8	8	1.25	48	23
4	12.25	2.75	6.19	9.50	7.00	1 1/8	8	2.12	1 1/4	8	1.44	70	30
5	14.75	3.12	7.31	11.50	8.50	1 3/8	8	2.38	1 1/2	8	1.69	114	43
6	15.50	3.00	8.50	12.50	8.50	1 1/4	12	2.25	1 3/8	8	1.56	116	45
8	19.00	3.50	10.62	15.50	9.62	1 1/2	12	2.56	1 5/8	8	1.88	224	66
10	23.00	3.88	12.75	19.00	11.12	1 3/4	12	3.00	1 7/8	8	2.12	345	95
12	26.50	4.12	15.00	22.50	12.12	1 7/8	16	3.31	2	8	2.25	456	124
14	29.50	4.25	16.25	25.00	13.25	2 1/8	16	3.56	2 1/4	8	2.56	540	150
16	32.50	5.00	18.50	27.75	14.62	2 3/8	16	4.00	2 1/2	8	2.81	762	178
18	36.00	5.50	21.00	30.50	16.00	2 5/8	16	4.38	2 3/4	8	3.12	1024	216
20	38.75	5.88	23.00	32.75	17.62	2 7/8	16	4.62	3	8	3.44	1234	245
24	46.00	6.75	27.25	39.00	20.12	3 3/8	16	5.38	3 1/2	8	4.00	1992	343

Dimensions are in inches. Weights are in pounds.

Material: Studding Outlets are most commonly provided in SA-105. They can also be made from a full range of stainless and alloy materials.

Thickness: The standard thickness shown above for all studding outlets is the minimum required per ASME Section VIII Division I Paragraph UG- 43(d) for thread engagement and an ID mount. It is important to note that each individual application should be analyzed for proper thickness. See general notes for more details.

Facing: The Studding Outlet minimum thickness "T" includes proper raised face per ANSI B16.5. Outlets can be supplied with any special facing as needed upon request.

Drilling and Tapping: Studding Outlets are furnished to ANSI B16.5 specifications unless otherwise specified. Thread depth is in accordance with ASME Section VIII Division I Para. UG-43(g) for a design temperature not to exceed 650°F, a base metal stress of 17,500 psi (g), and a stud stress of 25,000 psi (g). All other materials exceeding these stresses should be checked for UG-43 compliance.

Bore: Bore sizes shown above are standard. Other sizes can be furnished upon request.

Curving: All connections can be furnished contoured to fit any shell, head, or cone at an additional cost. Specify diameter to be mounted.

Class 2500 Studding Outlets

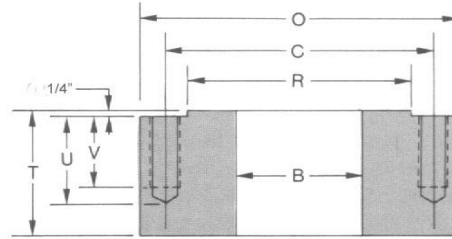

Flat Bottom

Bore Size	OD	Thickness	OD of RF	Stud Circle	Hole Dia	# of Holes	Hole Depth	Tap Size	T.P.I.	Tap Depth	Flat Bottom Weight	
											Base	per 1"
B	O	T	R	C			U			V		
1/2	5.25	2.00	1.38	3.50	21/32	4	1.31	3/4	10	0.88	10	6.1
3/4	5.50	2.00	1.69	3.75	21/32	4	1.31	3/4	10	0.88	11	6.6
1	6.25	2.12	2.00	4.25	49/64	4	1.44	7/8	9	1.00	15	8.5
1 1/4	7.25	2.25	2.50	5.12	7/8	4	1.56	1	8	1.12	22	11
1 1/2	8.00	2.50	2.88	5.75	1	4	1.81	1 1/8	8	1.25	29	14
2	9.25	2.25	3.62	6.75	7/8	8	1.56	1	8	1.12	34	18
2 1/2	10.50	2.50	4.12	7.75	1	8	1.81	1 1/8	8	1.25	49	23
3	12.00	2.75	5.00	9.00	1 1/8	8	2.12	1 1/4	8	1.44	71	30
4	14.00	3.25	6.19	10.75	1 3/8	8	2.38	1 1/2	8	1.69	112	40
5	16.50	3.75	7.31	12.75	1 5/8	8	2.81	1 3/4	8	2.00	179	55
6	19.00	4.12	8.50	14.50	1 7/8	8	3.31	2	8	2.25	259	72
8	21.75	4.38	10.62	17.25	1 7/8	12	3.31	2	8	2.25	345	91
10	26.50	5.12	12.75	21.25	2 3/8	12	4.00	2 1/2	8	2.81	590	134
12	30.00	5.50	15.00	24.38	2 5/8	12	4.38	2 3/4	8	3.12	799	168

Dimensions are in inches. Weights are in pounds.

Material: Studding Outlets are most commonly provided in SA-105. They can also be made from a full range of stainless and alloy materials.

Thickness: The standard thickness shown above for all studding outlets is the minimum required per ASME Section VIII Division I Paragraph UG-43(d) for thread engagement and an ID mount. It is important to note that each individual application should be analyzed for proper thickness.

Facing: The Studding Outlet minimum thickness "T" includes proper raised face per ANSI B16.5. Outlets can be supplied with any special facing as needed upon request.

Drilling and Tapping: Studding Outlets are furnished to ANSI B16.5 specifications unless otherwise specified. Thread depth is in accordance with ASME Section VIII Division I Para. UG-43(g) for a design temperature not to exceed 650°F, a base metal stress of 17,500 psi (g), and a stud stress of 25,000 psi (g). All other materials exceeding these stresses should be checked for UG-43 compliance.

Bore: Bore sizes shown above are standard. Other sizes can be furnished upon request.

Curving: All connections can be furnished contoured to fit any shell, head, or cone at an additional cost. Specify diameter to be mounted.

Wall Thicknesses

Nom Pipe Size	OD	NOMINAL WALL THICKNESS												
		Sch 10	Sch 20	Sch 30	STD Wall	Sch 40	Sch 60	EXT Hvy	Sch 80	Sch 100	Sch 120	Sch 140	Sch 160	XX Hvy
½	0.840	0.083	0.109	0.109	0.147	0.147	0.188	0.294
¾	1.050	0.083	0.113	0.113	0.154	0.154	0.219	0.308
1	1.315	0.109	0.133	0.133	0.179	0.179	0.250	0.358
1 ¼	1.660	0.109	0.140	0.140	0.191	0.191	0.250	0.382
1 ½	1.900	0.109	0.145	0.145	0.200	0.200	0.281	0.400
2	2.375	0.109	0.154	0.154	0.218	0.218	0.344	0.436
2 ½	2.875	0.120	0.203	0.203	0.276	0.276	0.375	0.552
3	3.500	0.120	0.216	0.216	0.300	0.300	0.438	0.600
3 ½	4.000	0.120	0.226	0.226	0.318	0.318	0.636
4	4.500	0.120	0.237	0.237	0.337	0.337	0.438	0.531	0.674
5	5.563	0.134	0.258	0.258	0.375	0.375	0.500	0.625	0.750
6	6.625	0.134	0.280	0.280	0.432	0.432	0.562	0.719	0.864
8	8.625	0.148	0.250	0.277	0.322	0.322	0.406	0.500	0.500	0.594	0.719	0.812	0.906	0.875
10	10.750	0.165	0.250	0.307	0.365	0.365	0.500	0.500	0.594	0.719	0.844	1.000	1.125	1.000
12	12.750	0.180	0.250	0.330	0.375	0.406	0.562	0.500	0.688	0.844	1.000	1.125	1.312	1.000
14	14.000	0.250	0.312	0.375	0.375	0.438	0.594	0.500	0.750	0.938	1.094	1.250	1.406
16	16.000	0.250	0.312	0.375	0.375	0.500	0.656	0.500	0.844	1.031	1.219	1.438	1.594
18	18.000	0.250	0.312	0.438	0.375	0.562	0.750	0.500	0.938	1.156	1.375	1.562	1.781
20	20.000	0.250	0.375	0.500	0.375	0.594	0.812	0.500	1.031	1.281	1.500	1.750	1.969
22	22.000	0.250	0.375	0.500
24	24.000	0.250	0.375	0.562	0.375	0.688	0.969	0.500	1.219	1.531	1.812	2.062	2.344
26	26.000	0.375	0.500
30	30.000	0.312	0.500	0.625	0.375	0.500
36	36.000	0.312	0.500	0.625	0.375	0.750	0.500
40	40.000	0.375	0.500
42	42.000	0.375	0.500
48	48.000	0.375	0.500

Dimensions are in inches.

1. Light Wall thicknesses are identical to stainless steel Schedule 10S in sizes through 12", and to Schedule 10 sizes 14", and larger.
2. Standard Wall thicknesses are identical to stainless steel Schedule 40S in sizes through 10".
3. Extra Heavy Wall thicknesses are identical to stainless steel Schedule 80S in sizes through 8".
4. Other types, sizes, and thicknesses of flanges can be provided to meet application.
5. Stocked and manufactured in carbon steel, stainless steel, and variety of other metals and alloy.
6. Inside pipe diameters are provide on the following page.

Weld Neck Flange Bores

Nom Pipe Size	OD	NOMINAL BORE												
		Sch 10	Sch 20	Sch 30	STD Wall	Sch 40	Sch 60	EXT Hvy	Sch 80	Sch 100	Sch 120	Sch 140	Sch 160	XX Hvy
½	0.840	0.674	0.622	0.622	0.546	0.546	0.464	0.252
¾	1.050	0.884	0.824	0.824	0.742	0.742	0.612	0.434
1	1.315	1.097	1.049	1.049	0.957	0.957	0.815	0.599
1 ¼	1.660	1.442	1.380	1.380	1.278	1.278	1.160	0.896
1 ½	1.900	1.682	1.610	1.610	1.500	1.500	1.338	1.100
2	2.375	2.157	2.067	2.067	1.939	1.939	1.687	1.503
2 ½	2.875	2.635	2.469	2.469	2.323	2.323	2.125	1.771
3	3.500	3.260	3.068	3.068	2.900	2.900	2.624	2.300
3 ½	4.000	3.760	3.548	3.548	3.364	3.364	2.728
4	4.500	4.260	4.026	4.026	3.826	3.826	3.624	3.438	3.152
5	5.563	5.295	5.047	5.047	4.813	4.813	4.563	4.313	4.063
6	6.625	6.357	6.065	6.065	5.761	5.761	5.501	5.187	4.897
8	8.625	8.329	8.125	8.071	7.981	7.981	7.813	7.625	7.625	7.437	7.187	7.001	6.813	6.875
10	10.750	10.420	10.250	10.136	10.020	10.020	9.750	9.750	9.562	9.312	9.062	8.750	8.500	8.750
12	12.750	12.390	12.250	12.090	12.000	11.938	11.626	11.750	11.374	11.062	10.750	10.500	10.126	10.750
14	14.000	13.500	13.376	13.250	13.250	13.124	12.812	13.000	12.500	12.124	11.812	11.500	11.188
16	16.000	15.500	15.376	15.250	15.250	15.000	14.688	15.000	14.312	13.938	13.562	13.124	12.812
18	18.000	17.500	17.376	17.124	17.250	16.876	16.500	17.000	16.124	15.688	15.250	14.876	14.438
20	20.000	19.500	19.250	19.000	19.250	18.812	18.376	19.000	17.938	17.438	17.000	16.500	16.062
22	22.000	21.500	21.250	21.000
24	24.000	23.500	23.250	22.876	23.250	22.624	22.062	23.000	21.562	20.938	20.376	19.876	19.312
26	26.000	25.250	25.000
30	30.000	29.376	29.000	28.750	29.250	29.000
36	36.000	35.376	35.000	34.750	35.250	34.500	35.000
40	40.000	39.250	39.000
42	42.000	41.250	41.000
48	48.000	47.250	47.000

Dimensions are in inches.

1. Source: ANSI B36.10
2. These dimensions are the same for inside pipe diameter. **ALWAYS** specify bore when ordering.
3. Other types, sizes, and thicknesses of flanges can be provided to meet application.
4. Stocked and manufactured in carbon steel, stainless steel, and a variety of other metals and alloys.
5. Wall thicknesses are provided on the previous page.

DIMENSIONS OF RING-JOINT FACINGS



Tolerances

E (depth)	+0.016 -0
F (Width)	±0.008
P (pitch diam)	±0.005
R (radius at bottom)	Max
23° (angle)	±1/2°

Nominal Pipe Size							Groove Dimensions					Diameter of Raised Portion K					
150 PSI	300 PSI	400 PSI	600 PSI	900 PSI	1500 PSI	2500 PSI	Groove #	Pitch Dia	Depth	Width	Radius at Bottom	150 PSI	300 400 600 PSI	900 PSI	1500 PSI	2500 PSI	Depth
								P	E	F	R						E
.....	1/2	1/2	R11	1-11/32	7/32	9/32	1/32	2	7/32
.....	1/2	12	1-9/16	1/4	11/32	1/32	2-3/8	2-3/8	1/4
.....	3/4	3/4	1/2	13	1-11/16	1/4	11/32	1/32	2-1/2	2-9/16	1/4
.....	3/4	14	1-3/4	1/4	11/32	1/32	2-5/8	2-5/8	1/4
1	15	1-7/8	1/4	11/32	1/32	2-1/2	1/4
.....	1	1	1	3/4	16	2	1/4	11/32	1/32	2-3/4	2-13/16	2-13/16	2-7/8	1/4
1-1/4	17	2-1/4	1/4	11/32	1/32	2-7/8	1/4
.....	1-1/4	1-1/4	1-1/4	1	18	2-3/8	1/4	11/32	1/32	3-1/8	3-3/16	3-3/16	3-1/4	1/4
1-1/2	19	2-9/16	1/4	11/32	1/32	3-1/4	1/4
.....	1-1/2	1-1/2	1-1/2	20	2-11/16	1/4	11/32	1/32	3-9/16	3-5/8	3-5/8	1/4
.....	1-1/4	21	2-27/32	5/16	15/32	1/32	4	5/16
2	22	3-1/4	1/4	11/32	1/32	4	1/4
.....	2	2	1-1/2	23	3-1/4	5/16	15/32	1/32	4-1/4	4-1/2	5/16
.....	2	24	3-3/4	5/16	15/32	1/32	4-7/8	4-7/8	5/16
2-1/2	25	4	1/4	11/32	1/32	4-3/4	1/4
.....	2-1/2	2-1/2	2	26	4	5/16	15/32	1/32	5	5-1/4	5/16
.....	2-1/2	27	4-1/4	5/16	15/32	1/32	5-3/8	5/16
.....	2-1/2	28	4-3/8	3/8	17/32	1/16	5-7/8	3/8
3	29	4-1/2	1/4	11/32	1/32	5-1/4	1/4
.....	30	4-5/8	5/16	15/32	1/32	5/16
.....	3	3	3	31	4-7/8	5/16	15/32	1/32	5-3/4	6-1/8	5/16
.....	3	32	5	3/8	17/32	1/16	6-5/8	3/8
3-1/2	33	5-3/16	1/4	11/32	1/32	6-1/16	1/4
.....	3-1/2	3-1/2	34	5-3/16	5/16	15/32	1/32	6-1/4	5/16
.....	3	35	5-3/8	5/16	15/32	1/32	6-5/8	5/16
4	36	5-7/8	1/4	11/32	1/32	6-3/4	1/4
.....	4	4	4	4	37	5-7/8	5/16	15/32	1/32	6-7/8	7-1/8	5/16
.....	4	38	6-3/16	7/16	21/32	1/16	8	7/16
.....	4	39	6-3/8	5/16	15/32	1/32	7-5/8	5/16
5	40	6-3/4	1/4	11/32	1/32	7-5/8	1/4
.....	5	5	5	5	41	7-1/8	5/16	15/32	1/32	8-1/4	8-1/2	5/16
.....	5	42	7-1/2	1/2	25/32	1/16	9-1/2	1/2
6	43	7-5/8	1/4	11/32	1/32	8-5/8	1/4
.....	5	44	7-5/8	5/16	15/32	1/32	9	5/16
.....	6	6	6	6	45	8-5/16	5/16	15/32	1/32	9-1/2	9-1/2	5/16

Dimensions in inches. RF height matches depth of groove.

DIMENSIONS OF RING-JOINT FACINGS

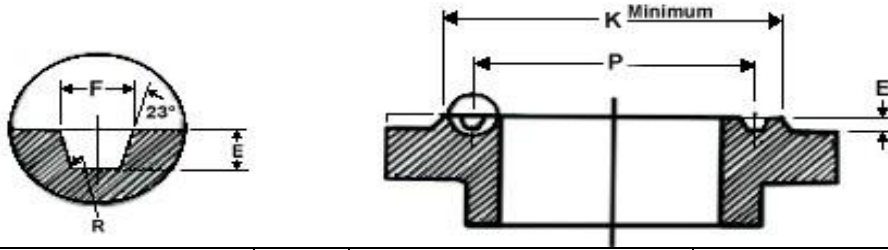

Nominal Pipe Size							Groove #	Groove Dimensions				Diameter of Raised Portion K					
150 PSI	300 PSI	400 PSI	600 PSI	900 PSI	1500 PSI	2500 PSI		Pitch Dia	Depth	Width	Radius at Bottom	150 PSI	300 PSI 400 PSI 600 PSI	900 PSI	1500 PSI	2500 PSI	Depth
							P	E	F	R							E
					6		R46	8-5/16	3/8	17/32	1/16				9-3/4		3/8
						6	47	9	1/2	25/32	1/16					11	1/2
8							48	9-3/4	1/4	11/32	1/32	10-3/4					1/4
	8	8	8	8			49	10-5/8	5/16	15/32	1/32	11-7/8	12-1/8				5/16
					8		50	10-5/8	7/16	21/32	1/16				12-1/2		7/16
						8	51	11	9/16	29/32	1/16					13-3/8	9/16
10							52	12	1/4	11/32	1/32	13					1/4
	10	10	10	10			53	12-3/4	5/16	15/32	1/32		14	14-1/4			5/16
					10		54	12-3/4	7/16	21/32	1/16				14-5/8		7/16
						10	55	13-1/2	11/16	1-3/16	3/32					16-3/4	11/16
12							56	15	1/4	11/32	1/32	16					1/4
	12	12	12	12			57	15	5/16	15/32	1/32		16-1/4	16-1/2			5/16
					12		58	15	9/16	29/32	1/16				17-1/4		9/16
14							59	15-5/8	1/4	11/32	1/32	16-3/4					1/4
						12	60	16	11/16	1-5/16	3/32					19-1/2	11/16
	14	14	14				61	16-1/2	5/16	15/32	1/32		18				5/16
				14			62	16-1/2	7/16	21/32	1/16			18-3/8			7/16
					14		63	16-1/2	5/8	1-1/16	3/32				19-1/4		5/8
16							64	17-7/8	1/4	11/32	1/32	19					1/4
	16	16	16				65	18-1/2	5/16	15/32	1/32		20				5/16
					16		66	18-1/2	7/16	21/32	1/16			20-5/8			7/16
						16	67	18-1/2	11/16	1-3/16	3/32				21-1/2		11/16
18							68	20-3/8	1/4	11/32	1/32	21-1/2					1/4
	18	18	18				69	21	5/16	15/32	1/32		22-5/8				5/16
					18		70	21	1/2	25/32	1/16			23-3/8			1/2
						18	71	21	11/16	1-3/16	3/32				24-1/8		11/16
20							72	22	1/4	11/32	1/32	23-1/2					1/4
	20	20	20				73	23	3/8	17/32	1/16		25				3/8
					20		74	23	1/2	25/32	1/16			25-1/2			1/2
						20	75	23	11/16	1-5/16	3/32			—	26-1/2		11/16
24							76	26-1/2	1/4	11/32	1/32	28					1/4
	24	24	24				77	27-1/4	7/16	21/32	1/16		29-1/2				7/16
					24		78	27-1/4	5/8	1-1/16	3/32			30-3/8			5/8
						24	79	27-1/4	13/16	17/16	3/32				31-1/4		13/16

Dimensions in inches. Raised face height matches depth of groove

TOLERANCES: ASME B16.5

7.1 General

For the purpose of determining conformance with this Standard, the convention for fixing significant digits where limits, maximum or minimum values are specified, shall be rounded as defined in ASTM Practice E 29. This requires that an observed or calculated value shall be rounded to the nearest unit in the last right hand digit used for expressing the limit. The listing of decimal tolerances does not imply a particular method of measurement.

7.2 Center-to-contact surfaces and Center-to-End Tolerances.

Required tolerances for various flanges and flanged fitting elements are as follows:

(a) Center-to-Contact Surface Other Than Ring Joint:

NPS < 10	:t1.0mm (t0.03 in)
NPS > 12	:t1.5mm (t0.06 in)

(b) Center-to-End (Ring Joint):

NPS < 10	t1.0 mm (i0.03 in.)
NPS > 12	±1.5 mm (i0.06 in.)

(c) Contact Surfaces-to -Contact Surface Other Than Ring Joint:

NPS < 10	±2.0 mm (:t0.06 in.)
NPS > 12	±3.0 mm (:t0.12 in.)

(d) End-to-End (Ring Joint)

NPS < 10	±2.0 mm (±0.06 in.)
NPS > 12	±3.0 mm (±0.12 in.)

7.3 Facings

Required tolerances for various flange and flanged fitting facings are as follows:

(a) Inside and outside diameter of large and small tongue and groove and female, t0.5 mm (:t0.02 in).

(b) Outside diameter, 2.0 mm (0.06 in.) raised face: t1.0 mm (:t0.03 in.)

(c) Outside diameter, 7.0 mm (0.25 in.) raised face: t0.5 mm (±0.02 in.)

(d) Ring joint groove tolerances are shown in Table 5 (Table F5 of Annex F).

7.4 Flange Thickness

Required tolerances for flange thickness are as follows.

NPS < 18,	+ 3.0, -0.0 mm (+0.12,-0.0in.)
NPS > 20,	+ 5.0, -0.0 mm (+0.19, -0.0 in.)

The plus tolerance is applicable to bolting bearing surfaces whether as-forged, as-cast, spot-faced or back-faced. See para.6, 6.

7.5 Welding End Flange Ends and Hubs

7.5.1 Outside Diameter. Required tolerances for the nominal outside diameter dimension A of Figs' 8 and 9 (Figs. F8 and F9 of Annex F) of welding ends of welding neck flanges are as follows:

NPS < 5	+2.0, -1.0 mm (+0.09, -0.03 in.)
NPS > 6	+4.0, -1.0 mm (+0.16, -0.03 in.)

7.5.2 Inside Diameter. Required tolerances for the nominal inside diameter of welding ends of welding neck flanges and smaller bore of socket welding flanges (dimension B in the referenced figures) are as follows: For Figs. 8 and 9 (Figs. F8 and F9 of Annex F) the tolerances are

NPS < 10	±1.0 mm (±0.03 in.)
12 < NPS < 18	:t1.5 mm (i0.06 in.)
NPS > 20,	±3.0, -1.5 mm (+0.12,-0.06 in.)

For Figs. 10 (Figs. F10 of Annex F) the tolerances are

NPS < 10	+ 0.0, -1.0 mm (+0.0,-0.03in.)
NPS > 12	+ 0.0, -1.5 mm (+0.0,-0.06 in.)

7.5.3 Backing Ring Contact Surface. Required tolerances for the bore of the backing ring contact surface of welding neck flanges dimension C of Figs. 10 and 11 (Figs. F10 and F11 of Annex F) are as follows.

2 < NPS < 24	+ 0.25,-0.0 mm (+0.01,-0.00in.)
--------------	---------------------------------

7.5.4 Hub Thickness, despite the tolerances specified for dimensions A and B, the thickness of the hub at the welding end shall not be less than 87 1/2% of the nominal thickness of the pipe, having an under tolerance of 12.5% for the pipe wall thickness to which the flange is to be attached, or the minimum wall thickness as specified by the purchaser

7.6 Length Through Hub on Welding Neck Flanges.

Flange Weights

		1/2	3/4	1	1 1/4	1 1/2	2	2 1/2	3	3 1/2	4	5	6	8	10	12	14	16	18	20	22	24
150#	SO	1	2	2	3	3	5	8	9	11	13	15	19	30	43	64	90	106	130	165	185	220
	THRD	1	2	2	3	3	5	8	9	12	13	15	19	30	43	64	90	98	130	165	185	220
	SW	2	2	2	3	3	5	8	9	11	13	15	19	30	43	64	90	98	130	165	185	220
	LJ	1	2	2	3	3	5	8	9	11	13	15	19	30	43	64	105	140	160	195	245	275
	BLD	2	2	2	3	4	5	7	9	13	17	20	27	47	70	123	140	180	220	285	355	430
	WN	2	2	3	3	4	6	10	11.5	12	16.5	21	26	42	54	88	114	140	165	197	225	268
300#	SO	2	3	3	4.5	6.5	7	10	13	17	23.5	29	39	58	81	115	165	210	253	315	370	490
	THRD	2	3	3	4.5	6.5	7	10	14	17	24	31	39	58	81	115	165	220	280	325	370	490
	SW	3	3	3	4	6	7	10	13	17	22	28	39	58	81	115	165	190	250	315	370	475
	LJ	2	3	3	4.5	6.5	7	10	14.5	17	24	28	39	58	91	140	190	234	305	375	435	550
	BLD	2	3	4	6	7	8	12	16	21	28	37	50	81	124	185	250	315	414	515	640	800
	WN	2	3	4	5	7	9	12	18	20	26.5	36	45	69	100	142	206	250	320	400	465	580
400#	SO	2	3	3.5	4.5	6.5	8	12	15	21	26	31	44	67	91	130	191	253	310	378	405	539
	THRD	2	3	3.5	4.5	6.5	8	12	15	21	26	31	44	67	91	130	191	253	310	378	405	539
	SW	2	3	3.5	4.5	6.5	8	12	15	21	26	31	44	67	91	130	191	253	310	378	405	539
	LJ	2	3	3.5	4.5	6.5	8	11	14	20	25	29	40	64	110	152	210	280	345	420	455	615
	BLD	2	3	4	6	8	10	15	20	29	33	44	61	100	155	226	310	398	502	621	720	936
	WN	3	3.5	4	4.5	8	10	14	18	26	35	43	57	89	125	175	233	295	360	445	505	640
600#	SO	2	3	4	5	7	9	13	16	21	37	63	80	115	177	215	259	366	476	612	590	876
	THRD	2	3	4	5	7	9	13	16	21	37	63	80	115	177	215	259	366	476	612	590	876
	SW	2	3	4	5	7	9	13	16	21	37	63	80	115	177	215	259	366	476	612	590	876
	LJ	2	3	4	5	7	9	12	15	20	36	63	78	112	195	240	290	400	469	604	670	866
	BLD	3	4	4	6	8	10	15	20	29	41	68	86	140	231	295	378	527	665	855	1000	1250
	WN	3	4	4	6	8	12	18	23	26	42	68	81	120	190	226	347	481	555	690	720	977
900#	SO	6	6	7.5	10	14	22	31	36	-	53	83	110	172	245	326	400	459	647	792	-	1480
	THRD	6	6	7.5	10	14	22	31	36	-	53	83	110	172	245	326	400	459	647	792	-	1480
	SW	6	6	7.5	10	14	22	31	36	-	53	83	110	172	245	326	400	459	647	792	-	1480
	LJ	6	6	7.5	10	14	21	25	29	-	51	81	105	190	277	371	415	488	670	868	-	1659
	BLD	4	6	9	10	14	25	32	35	-	54	87	115	200	290	415	520	619	880	1107	-	2099
	WN	7	7	8.5	10	14	24	31	36	-	53	86	110	187	268	372	562	685	924	1164	-	2107
1500#	SO	6	6	8	10	14	25	36	48	-	73	132	165	260	436	667	940	1250	1625	2050	-	2825
	THRD	6	6	8	10	14	25	36	48	-	73	132	165	260	436	667	940	1520	1625	2050	-	2825
	SW	6	6	8	10	14	25	36	48	-	73	132	165	260	436	667	940	1520	1625	2050	-	2825
	LJ	6	6	8	10	14	25	35	47	-	75	140	170	286	485	749	890	1520	1475	1775	-	2825
	BLD	4	6	9	10	14	25	35	48	-	73	140	160	302	510	755	975	1300	1750	2225	-	3625
	WN	7	7	9	10	14	25	36	48	-	73	132	165	275	455	690	940	1250	1625	2050	-	3325
2500#	THRD	7	9	12	18	25	38	55	83	-	127	210	323	485	925	1300	-	-	-	-	-	-
	LJ	7	8	12	17	24	37	53	80	-	122	204	314	471	897	1262	-	-	-	-	-	-
	BLD	7	10	12	18	25	39	56	86	-	133	223	345	533	1025	1464	-	-	-	-	-	-
	WN	8	9	13	20	28	42	52	94	-	146	244	378	576	1068	1608	-	-	-	-	-	-