



Blue Carbon
蓝晶易碳

**POTENCIA
VERDE®**

WIND • SOLAR & CONTRACTORS



Carbon Free

BCT-CF1.0

PV Energy Storage System

It is a portable power generation/storage/lighting device, designed for areas without electricity or less electricity. Can be used for home, outdoor activities, commercial places, tourism, camping, farms, plantations, night markets, restaurants, farmhouses, etc. Can be used as a necessary power backup for survival activities. This product needs no wires and installation. It has the strengths of DC low-voltage output, high safety, no consumption of electricity, and a long life, and is energy saving and environmental friendly.

Product Introduction

**Press the switch to start work,
short press to turn on control panel light,**

Short press to switch in turn flood light, high beam light, SOS light.

long press to shut down.

- Switch
- DC Output
- Type-C Output
- USB Output
- DC Input

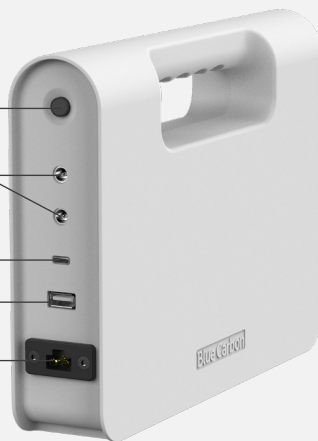

- High Beam
- Power indicator
- Flood Light
- SOS Light



Blue Carbon, no need electricity bill at all.



Blue Carbon
蓝晶易碳

**POTENCIA
 VERDE®**

WIND • SOLAR & CONTRACTORS

Technical Parameters

Model	BCT-CF1.0
DC output	Two circuits DC output 3.2V
USB output	One circuit output 5V/2A
Type-C output	One circuit output 5V/2A
Battery electric	LiFePO4 battery 80W · h
Solar panel	5V/15W
Built-in lamp	High Beam(Common 9W LED), Press the switch to control
	Flood Light (Common 9W LED), Press the switch to control
	SOS Light (Common 3W LED), Press the switch to control
External lamp	Common 6W LED × 2pcs; External lamp cable length 3m
Lighting time	One external lamp works 13 hrs; Two external lamps work 6 hrs; For the built-in lamp, high beam works 8 hrs, flood light works 8 hrs and SOS light works 26 hrs.
Warranty	Battery warranty 5 years

Standard Accessories



Carbon Free



External Lamps



USB Electric Charging Wire

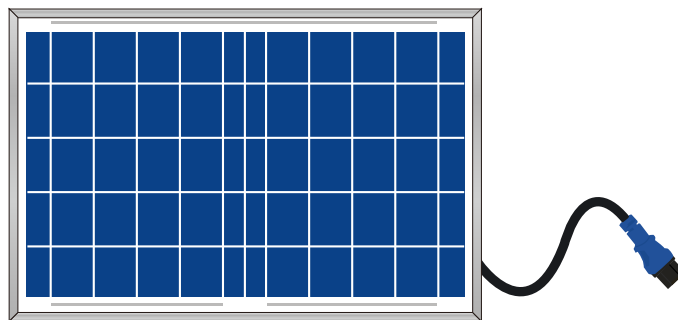

Solar Panel



Blue Carbon
蓝晶易碳

**POTENCIA
VERDE®**

WIND • SOLAR & CONTRACTORS

Product Size

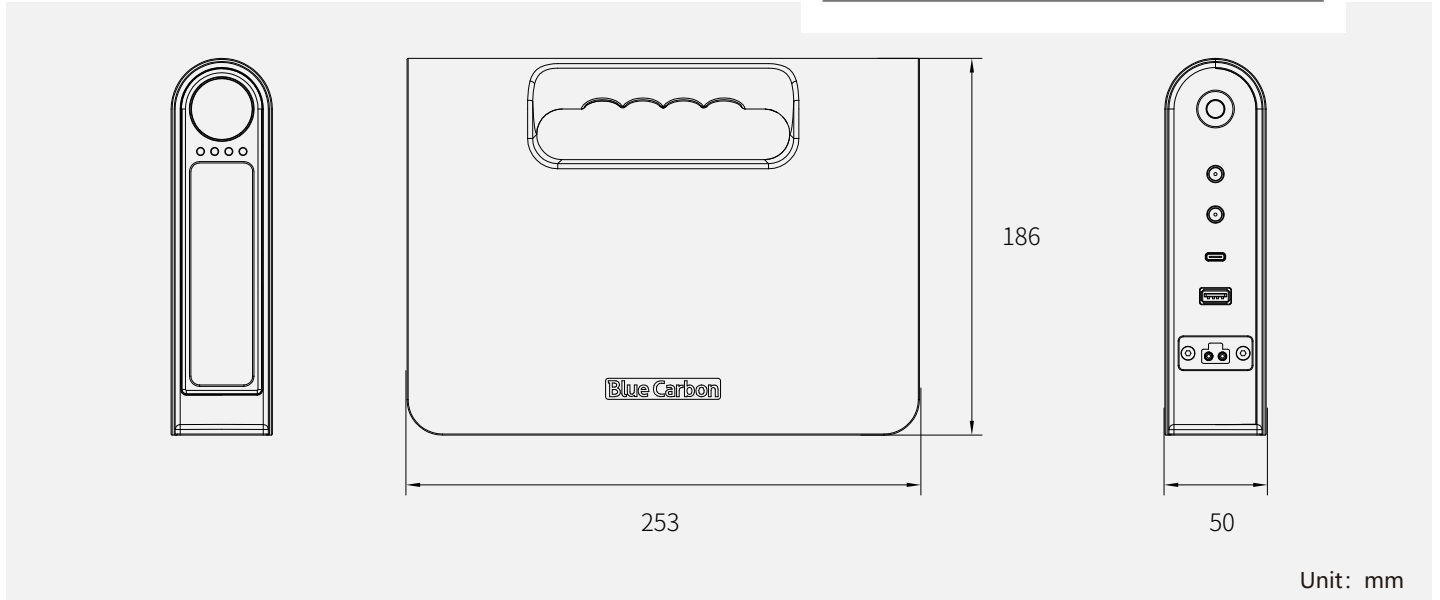

Advantages

- Compact design, small size, convenient to carry.
- Using LiFePO₄ battery, the life span is more than 12 years.
- The shell is made of high-quality PC material, with self extinguishing, excellent electrical insulation, elongation, dimensional stability, chemical resistance, high strength, flame retardant, non-toxic and excellent performance;
- Built-in led and outer led all can meet, apply for many places and different environment.
- Integrated design, mould production, easy installation.
- Anti-dust design, DC output, safe and reliable.
- Integrated packing, easy transportation.

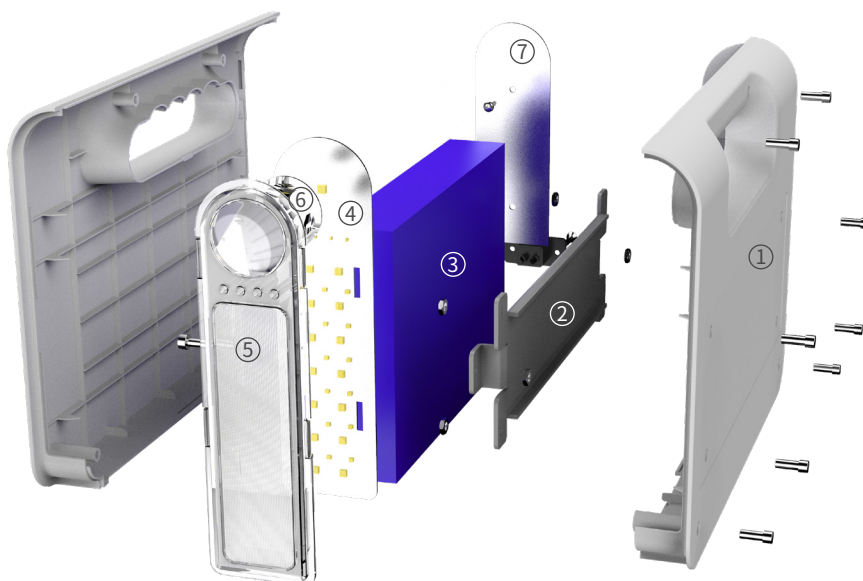

Tel: +507 394-6696

Cel: +507 6618-2630

E-mail: singh@potenciaverde.com



Blue Carbon
蓝晶易碳

BCT

Application Places



www.potenciaverde.com



Tel: +507 394-6696

Cel: +507 6618-2630

E-mail: singh@potenciaverde.com