



WIRE EDM INC.

LASER CUTTING, SCANNING & WIRE CUTTING AT ITS BEST

1380 Matheson Blvd. East, Unit #11,

Mississauga, ON. L4W 4P8

Tel: 905-629-7233, 905-629-8725

E-mail: wiredm@bellnet.ca

www.wiredminc.ca

Sample tube

Shawn S.

December 6, 2021



E-mail: wiredm@bellnet.ca

Workspace:

Project:

Drawing #:

Job #:

PO #:

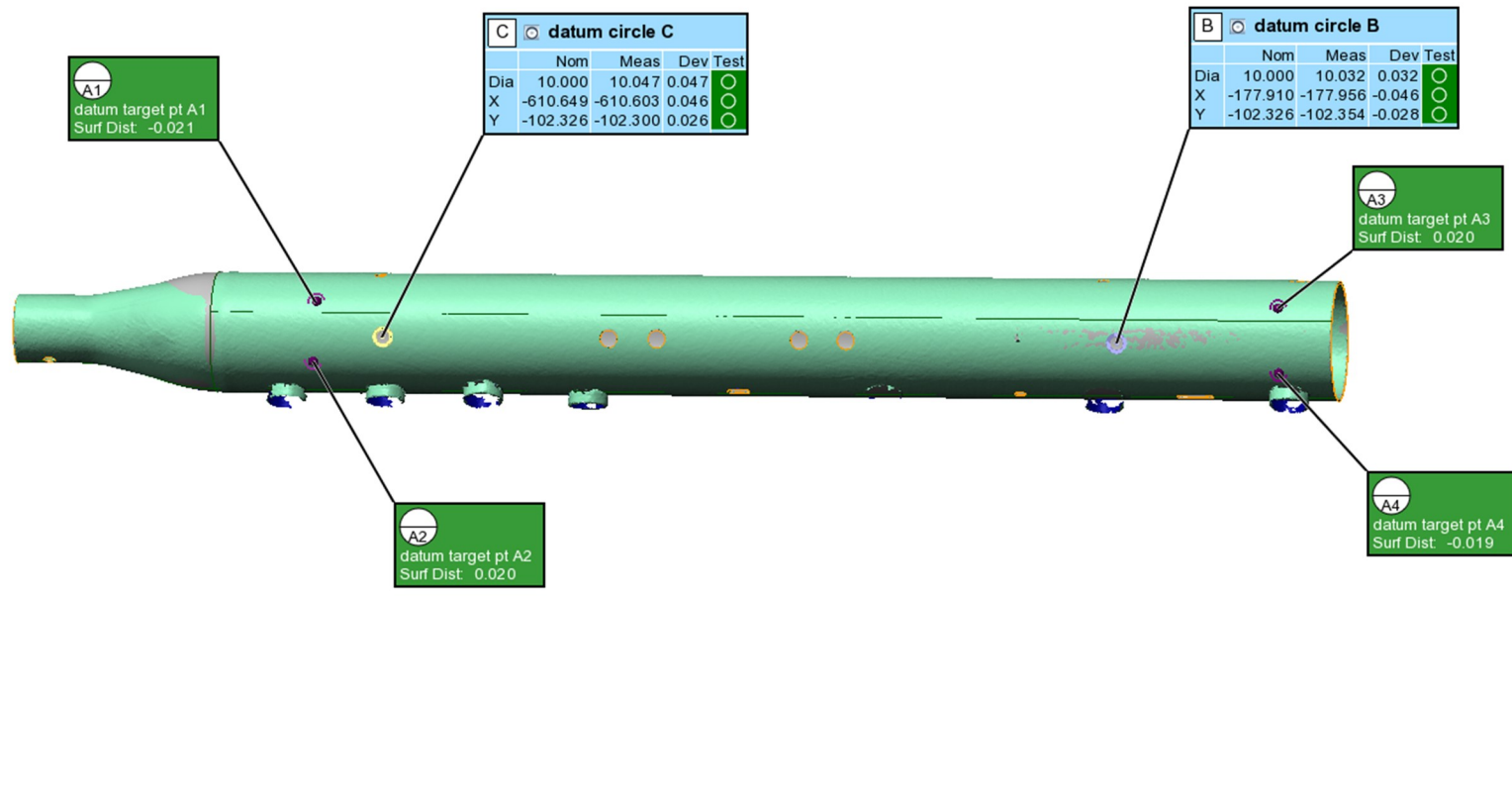

Organization:

WIRE EDM INC.

Part name:

Operator:

Part number:

E-mail:



wireedm@bellnet.ca

Piece:

piece 2

Feature Table

Units Millimeters
Coordinate System world
Data Alignments reference targets 1

Name	Control	Nom	Meas	Tol	Dev	Test	Out Tol
 datum circle B	Diameter	10.000	10.032	±0.100	0.032	Pass	
	X	-177.910	-177.956	±0.100	-0.046	Pass	
	Y	-102.326	-102.354	±0.100	-0.028	Pass	
 datum circle C	Diameter	10.000	10.047	±0.100	0.047	Pass	
	X	-610.649	-610.603	±0.100	0.046	Pass	
	Y	-102.326	-102.300	±0.100	0.026	Pass	

Organization: WIRE EDM INC.
Operator:
E-mail: wireedm@bellnet.ca

Part name:
Part number:
Piece: piece 2

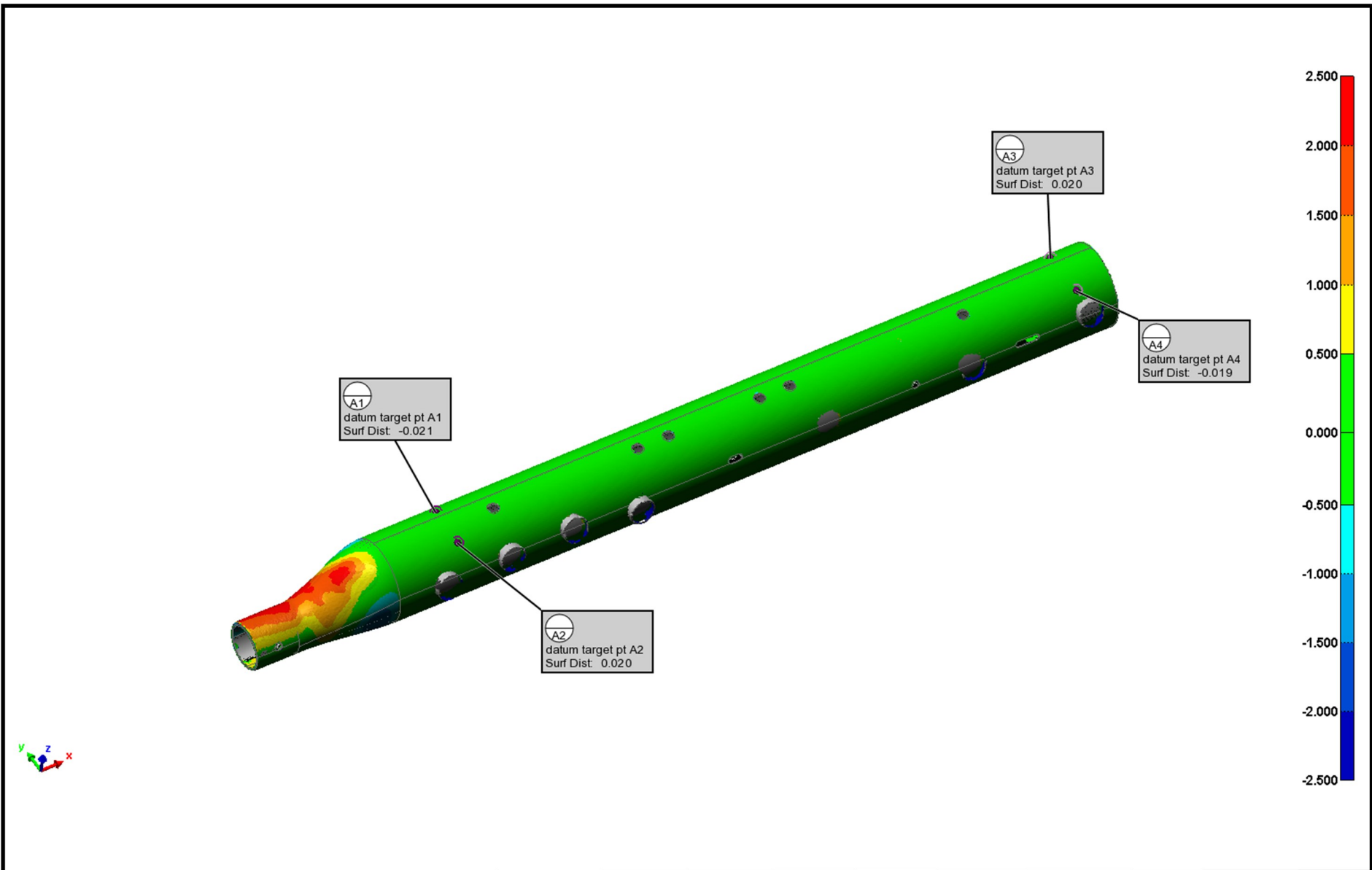

Organization: WIRE EDM INC.
Operator:
E-mail: wireedm@bellnet.ca

Part name:
Part number:
Piece: piece 2

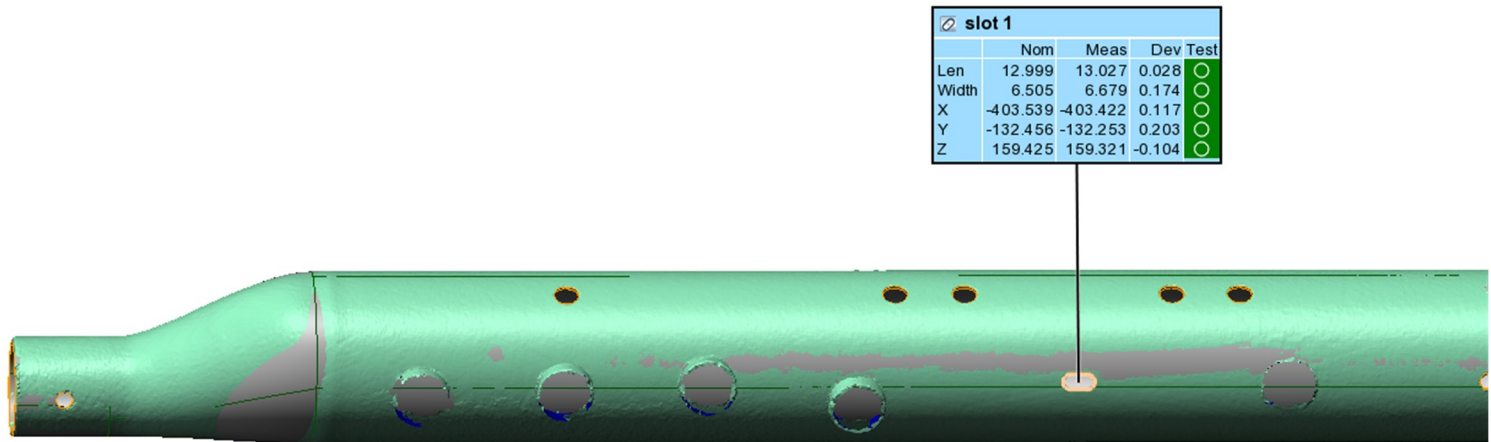

Organization:

WIRE EDM INC.

Part name:

Operator:

Part number:

E-mail:

wireedm@bellnet.ca

Piece:

piece 2

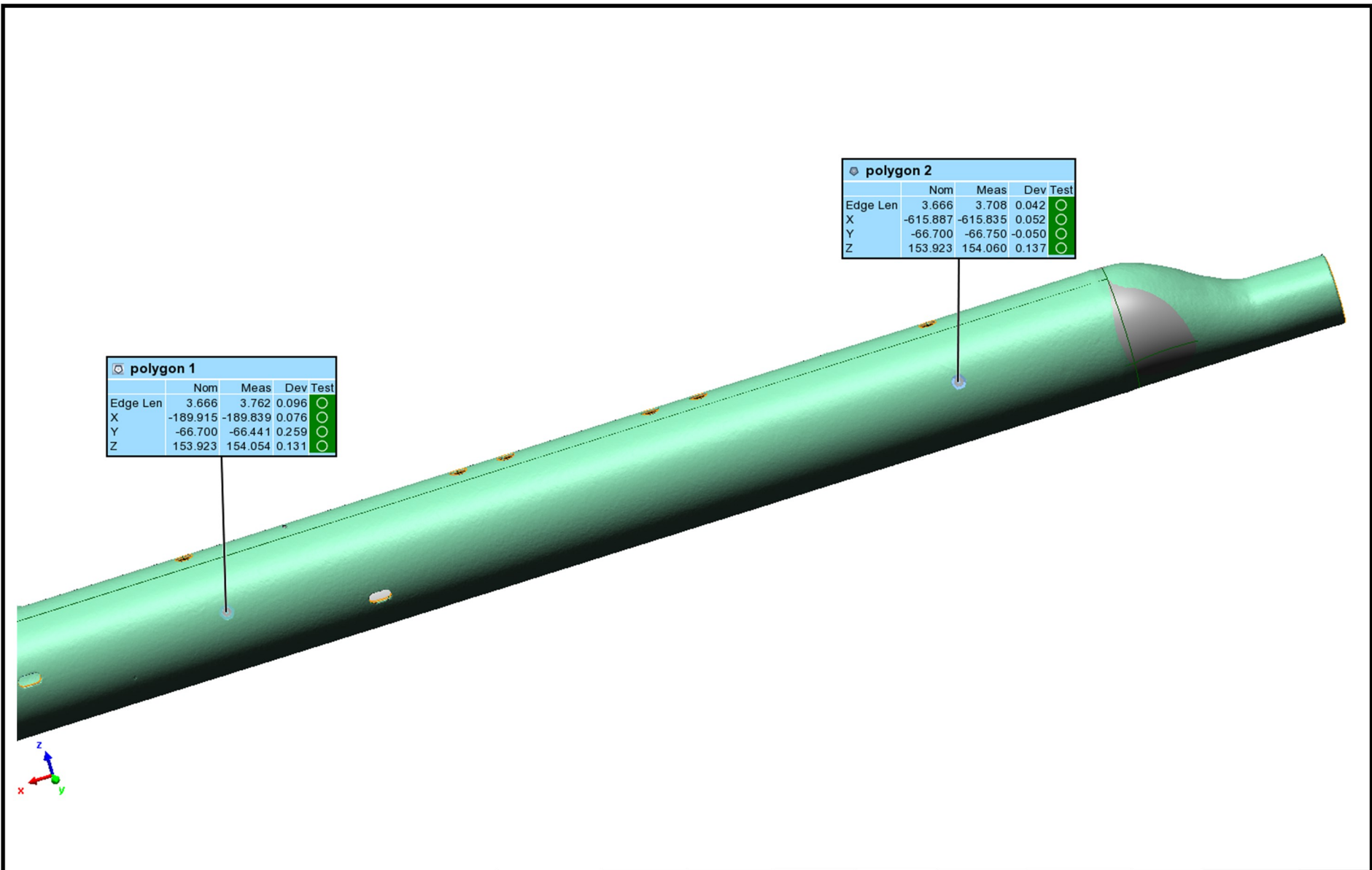

polygon 1				
	Nom	Meas	Dev	Test
Edge Len	3.666	3.762	0.096	○
X	-189.915	-189.839	0.076	○
Y	-66.700	-66.441	0.259	○
Z	153.923	154.054	0.131	○

polygon 2				
	Nom	Meas	Dev	Test
Edge Len	3.666	3.708	0.042	○
X	-615.887	-615.835	0.052	○
Y	-66.700	-66.750	-0.050	○
Z	153.923	154.060	0.137	○

Organization: WIRE EDM INC.
Operator:
E-mail: wireedm@bellnet.ca

Part name:
Part number:
Piece: piece 2

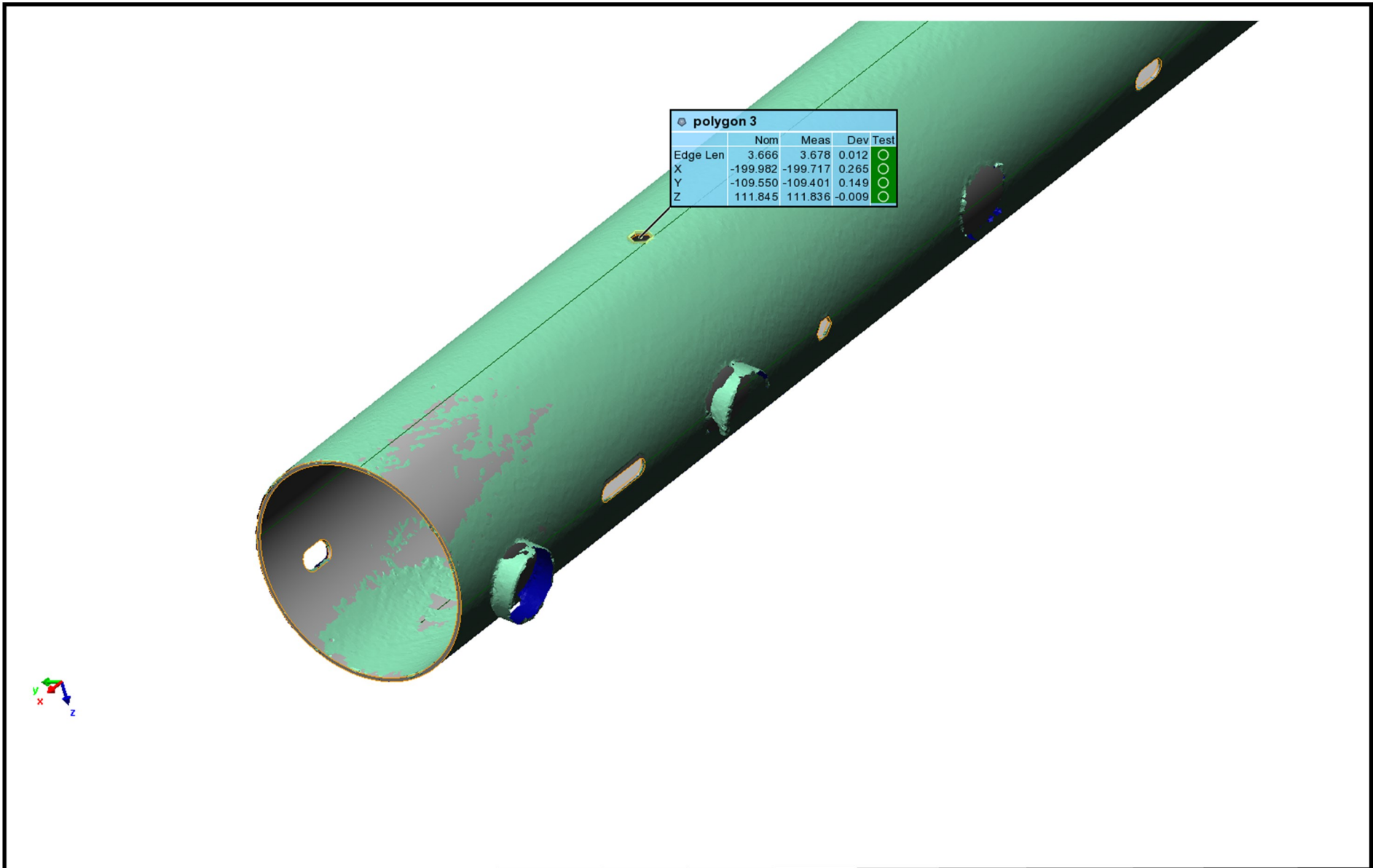

Organization:

WIRE EDM INC.

Part name:

Operator:

Part number:

E-mail:





wireedm@bellnet.ca

Piece:

piece 2

Feature Table

Units Millimeters
 Coordinate System world
 Data Alignments reference targets 1

Name	Control	Nom	Meas	Tol	Dev	Test	Out Tol
 polygon 1	Edge Length	3.666	3.762	+0.150/0.000	0.096	Pass	
	X	-189.915	-189.839	±0.500	0.076	Pass	
	Y	-66.700	-66.441	±0.500	0.259	Pass	
	Z	153.923	154.054	±0.500	0.131	Pass	
 polygon 2	Edge Length	3.666	3.708	+0.150/0.000	0.042	Pass	
	X	-615.887	-615.835	±0.500	0.052	Pass	
	Y	-66.700	-66.750	±0.500	-0.050	Pass	
	Z	153.923	154.060	±0.500	0.137	Pass	
 polygon 3	Edge Length	3.666	3.678	+0.150/0.000	0.012	Pass	
	X	-199.982	-199.717	±0.500	0.265	Pass	
	Y	-109.550	-109.401	±0.500	0.149	Pass	
	Z	111.845	111.836	±0.500	-0.009	Pass	
 slot 1	Length	12.999	13.027	±0.250	0.028	Pass	
	Width	6.505	6.679	±0.250	0.174	Pass	
	X	-403.539	-403.422	±0.500	0.117	Pass	
	Y	-132.456	-132.253	±0.500	0.203	Pass	
	Z	159.425	159.321	±0.500	-0.104	Pass	

Organization: WIRE EDM INC.
Operator:
E-mail: wireedm@bellnet.ca

Part name:
Part number:
Piece: piece 2