

Scenario:

At 8:30 am this morning, a freight train accident resulted in a derailment of 11 railcars. The derailment occurred in your local community. Responders have secured the immediate area, and have obtained some limited information on the materials contained in the 11 railcars. While the materials involved present a number of hazards, responders are particularly concerned about the materials in the following railcars:

UN # 1789
UN # 2428
Acetone
CAS # 108-91-8

At present, none of the railcars appear to be leaking any material. However, the four railcars listed above have sustained noticeable damage.

The forecast is calling for the following weather conditions at noon:

Wind: from the West; 12 mph with gusts to 22 mph (obtained from NWS)	
Ground Roughness: open country	Cloud Cover: Clear Skies
Air Temperature: 55° F	Stability Class: D
No Inversion Height	Relative Humidity: 33%

The forecast for 3:00 pm is

Wind: from the SE; 4 mph (obtained from NWS)	
Ground Roughness: open country	Cloud Cover: Partly Cloudy
Air Temperature: 65° F	Stability Class: D
No Inversion Height	Relative Humidity: 27%

You are directed to operate CAMEO and supply information to Incident Command for the duration of this event.

CAMEO Chemicals

1. Use CAMEO Chemicals to gather information for the various chemicals. (CAMEO Companion pages 31-34)
 - a. Are these materials liquid, solid, or gas?
 - b. Is it likely that these materials are carried in Liquid Tankers or Pressurized Tankers?
 - c. What are the primary hazards associated with these materials?
2. Use the CAMEO Chemicals “Predict Reactivity” module to evaluate the potential reactive hazards for this incident. (CAMEO Companion pages 34-35)
3. Determine the Initial Isolation Zone and Evacuation distances appropriate for this scenario. (CAMEO Companion pages 31-34)

MARPLOT

1. Launch MARPLOT
2. Select a location in your area to use as the incident site
3. Navigate to the incident location (CAMEO Companion pages 57-62)
4. Mark the incident location using the “Extras / Marked Point / Mark Click Point” menu (CAMEO Companion pages 65-66)
5. Use the “Circle” drawing tool to display the Immediate Isolation Zone on the map (CAMEO Companion pages 74, 81)
6. Use the “Polygon” drawing tool to display the largest ERG-suggestion downwind evacuation area
7. Copy and paste a screenshot of the mapped area from MARPLOT to WORD. (CAMEO Companion pages 85)

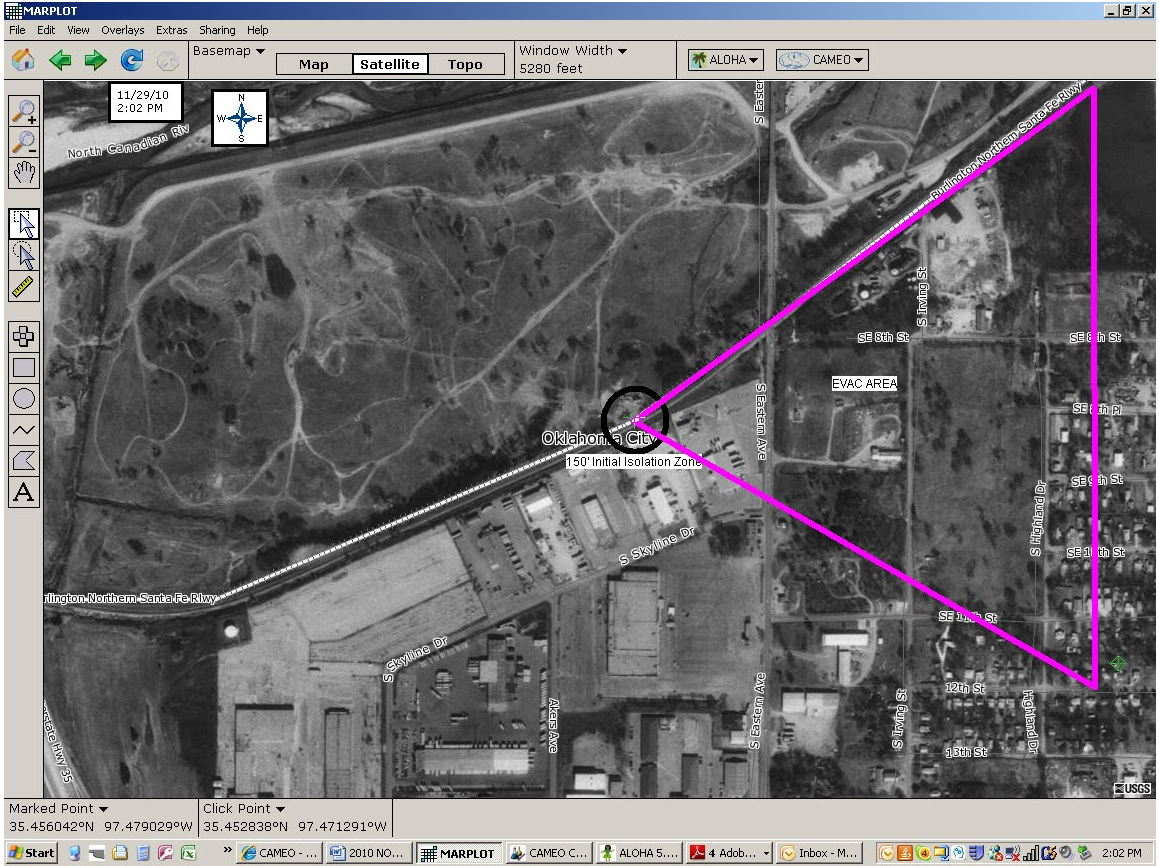

ALOHA

1. Determine which, if any, of these materials can be modeled using ALOHA.
 - a. For the first ALOHA scenario, use Acetone
 - b. Model for the Toxic, Vapor Cloud Explosion, and BLEVE zones
 - c. Repeat for the other substances
2. Use the following weather data:

Wind: 16 miles/hour from SW at 10 meters
Ground Roughness: open country Cloud Cover: 0 tenths
Air Temperature: 35° F Stability Class: D
No Inversion Height Relative Humidity: 22%

Use "Tank" for your Source option. (Consult http://worldtraderref.com/WTR_site/Rail_Cars/Guide_to_Rail_Cars.asp to determine the estimated Tank dimensions)

Dimensions

Length over couplers	59' 9"	18.21 m
Length over strikers	57' 1 ¹ / ₂ "	17.41 m
Truck centers	46' 3 ¹ / ₄ "	14.10 m
Height, extreme	15' 5"	4.70 m
Width, extreme	10' 7 ¹ / ₂ "	3.24 m

Weight/Capacity

Light weight	65,700 lbs.	29,801 kg
Gross rail load	263,000 lbs.	119,295 kg
Shell full capacity	30,000 gallons	113,562 liters

Tank

Inside diameter	9'11 ¹ / ₈ "	3.03 m
Length over tank heads	53' 10 ¹³ / ₁₆ "	16.43 m
Tank slope	¹ / ₄ " per foot	-
Plate thickness	⁷ / ₁₆ "	1.11 cm
Manway nozzle	20"	50.8 cm

NOTE: *from the above railcar guide, I input a 30,000-gallon tank capacity and 54 feet tank length to ALOHA; ALOHA then determined a Tank Diameter of 9.72 feet.*

SITE DATA:

Location: OKLAHOMA CITY, OKLAHOMA

Building Air Exchanges Per Hour: 1.26 (unsheltered single storied)
Time: December 1, 2010 0630 hours CST (user specified)

CHEMICAL DATA:

Chemical Name: ACETONE Molecular Weight: 58.08 g/mol
TEEL-1: 200 ppm TEEL-2: 3200 ppm TEEL-3: 5700 ppm
LEL: 26000 ppm UEL: 128000 ppm
Ambient Boiling Point: 130.7° F
Vapor Pressure at Ambient Temperature: 0.10 atm
Ambient Saturation Concentration: 105,579 ppm or 10.6%

ATMOSPHERIC DATA: (MANUAL INPUT OF DATA)

Wind: 16 miles/hour from SW at 10 meters
Ground Roughness: open country Cloud Cover: 0 tenths
Air Temperature: 35° F Stability Class: D
No Inversion Height Relative Humidity: 22%

SOURCE STRENGTH:

BLEVE of flammable liquid in horizontal cylindrical tank
Tank Diameter: 9.72 feet Tank Length: 54 feet
Tank Volume: 30000 gallons
Tank contains liquid
Internal Storage Temperature: 35° F
Chemical Mass in Tank: 172,918 pounds
Tank is 85% full
Percentage of Tank Mass in Fireball: 100%
Fireball Diameter: 272 yards Burn Duration: 15 seconds

Estimating BLEVE, VCE, and Toxic Threat Zone data: ACETONE

1. Enter the Tank dimensions as given above

Tank Size and Orientation

Select tank type and orientation:

Horizontal cylinder Vertical cylinder Sphere

Enter two of three values:

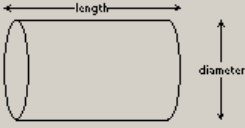
 diameter feet meters
length gallons cu feet
volume

2. Enter Chemical State and Temperature as “Liquid” and “Ambient”

Chemical State and Temperature

Enter state of the chemical:

Tank contains liquid
 Tank contains gas only
 Unknown

Enter the temperature within the tank:

Chemical stored at ambient temperature
 Chemical stored at degrees F C

3. Assume the railcar is essentially completely full at the time of the derailment and enter “85” % full by volume

Liquid Mass or Volume

Enter the mass in the tank OR volume of the liquid

The mass in the tank is:

pounds
 tons(2,000 lbs)
 kilograms

OR

Enter liquid level OR volume

The liquid volume is:

gallons
 cubic feet
 liters
 cubic meters

% full by volume

4. Select “BLEVE” as the Type of Tank Failure

Type of Tank Failure

Scenario:
Tank containing an unpressurized flammable liquid.

Type of Tank Failure:

Leaking tank, chemical is not burning and forms an evaporating puddle
 Leaking tank, chemical is burning and forms a pool fire
 BLEVE, tank explodes and chemical burns in a fireball

Potential hazards from BLEVE:

- Thermal radiation from fireball and pool fire
- Hazardous fragments and blast force from explosion
[cannot be modeled by ALOHA]
- Downwind toxic effects of fire byproducts
[cannot be modeled by ALOHA]

5. Accept the ALOHA default values for the BLEVE

BLEVE Percent Mass in Fireball

BLEVE / Fireball Scenario:
The higher the internal tank pressure [or tank temperature] at the time of tank failure, the larger the fireball. Any liquid not consumed by the fireball will form a pool fire.

Enter one of the following:

Percentage of mass in the fireball: [0 % - 100%]
100 %

Pressure inside the tank at time of failure:
86.0 psia mmHg
 atm Pa

Temperature inside the tank at time of failure:
246.1 degrees F C

OK Cancel Help

BLEVE AREA Threat Zone

Select the Display / Threat Zone menu

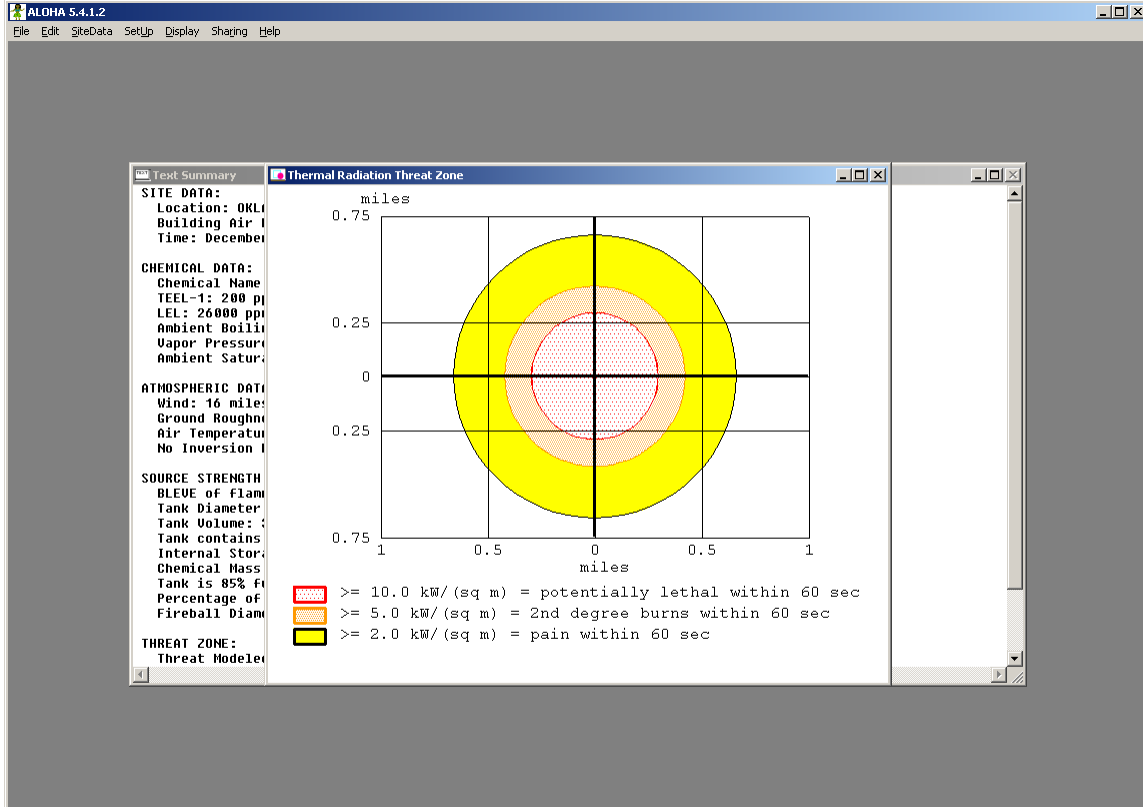

SOURCE STRENGTH:

BLEVE of flammable liquid in horizontal cylindrical tank
Tank Diameter: 9.72 feet Tank Length: 54 feet
Tank Volume: 30000 gallons
Tank contains liquid
Internal Storage Temperature: 35° F
Chemical Mass in Tank: 172,918 pounds
Tank is 85% full
Percentage of Tank Mass in Fireball: 100%
Fireball Diameter: 272 yards Burn Duration: 15 seconds

THREAT ZONE:

Threat Modeled: Thermal radiation from fireball
Red: 520 yards --- (10.0 kW/ (sq m) = potentially lethal within 60 sec)
Orange: 741 yards --- (5.0 kW/ (sq m) = 2nd degree burns within 60 sec)
Yellow: 1164 yards --- (2.0 kW/ (sq m) = pain within 60 sec)

VAPOR CLOUD EXPLOSION AREA

Using a 3-inch short pipe or valve located at the bottom of the tank

1. Use the same Tank Dimensions, Chemical State, and Liquid Volume as above
2. Select “Leaking tank, chemical is not burning and forms an evaporating puddle” as the Type of Tank Failure

The screenshot shows a dialog box titled "Type of Tank Failure" with a blue header. The "Scenario:" field contains the text "Tank containing an unpressurized flammable liquid." Below this, the "Type of Tank Failure:" section has three radio button options: "Leaking tank, chemical is not burning and forms an evaporating puddle" (which is selected), "Leaking tank, chemical is burning and forms a pool fire", and "BLEVE, tank explodes and chemical burns in a fireball". A text box below lists "Potential hazards from flammable chemical which is not burning as it leaks from tank:" with three bullet points: "- Downwind toxic effects", "- Vapor cloud flash fire", and "- Overpressure (blast force) from vapor cloud explosion". At the bottom are three buttons: "OK", "Cancel", and "Help".

3. Enter “Circular opening”, “3” inches; and “Short pipe or valve”

Area and Type of Leak

Select the shape that best represents the shape of the opening through which the pollutant is exiting



Circular opening Rectangular opening

Opening diameter: inches
 feet
 centimeters
 meters

Is leak through a hole or short pipe/valve?
 Hole Short pipe/valve

4. Enter “0” for the bottom of the leak is value

Height of the Tank Opening



The bottom of the leak is:
 in ft cm m
above the bottom of the tank

_____ OR _____

% of the way to the top of the tank

5. Select “Default soil”; “Use air temperature”; and “Unknown” for the Puddle Parameters

Puddle Parameters

Select ground type

- Default soil (select this if unknown)
- Concrete
- Sandy dry soil
- Moist sandy soil
- Water

Input ground temperature

- Use air temperature (select this if unknown)
- Ground temperature is deg. F C

Input maximum puddle diameter or area

- Unknown
- Maximum diameter is
- Maximum area is

ft
 yds
 meters

6. Select “Blast Area of Vapor Cloud” as the Hazard to Analyze

Hazard To Analyze

Scenario:
Flammable chemical escaping from tank.
Chemical is NOT on fire.

Choose Hazard to Analyze:

- Toxic Area of Vapor Cloud
- Flammable Area of Vapor Cloud
- Blast Area of Vapor Cloud Explosion

7. Select “unknown”; “ignited by spark or flame”; and “uncongested” for the Vapor Cloud Explosion Parameters

The screenshot shows a dialog box titled "Vapor Cloud Explosion Parameters". It contains three sections, each with a "Help" button:

- Time of vapor cloud ignition:** A radio button is selected for "unknown [show composite threat zone from all possible ignition times]".
- Type of vapor cloud ignition:** A radio button is selected for "ignited by spark or flame".
- Level of congestion :** (in the flammable part of the vapor cloud) A radio button is selected for "uncongested, easy to walk through (e.g. residential neighborhood)".

At the bottom are "OK" and "Cancel" buttons.

8. Accept the ALOHA defaults for the Level of Concern values

The screenshot shows a dialog box titled "Overpressure Level of Concern". It contains three sections for selecting the Level of Concern (LOC) for different threat zones:

- Red Threat Zone:** The LOC is set to "8.0 psi = destruction of buildings".
- Orange Threat Zone:** The LOC is set to "3.5 psi = serious injury likely".
- Yellow Threat Zone:** The LOC is set to "1.0 psi = shatters glass".

At the bottom, there is a "Show confidence lines:" section with two radio buttons: "only for longest threat zone" (selected) and "for each threat zone". Below this are "OK", "Cancel", and "Help" buttons.

9. Select the Display / Threat Zone menu

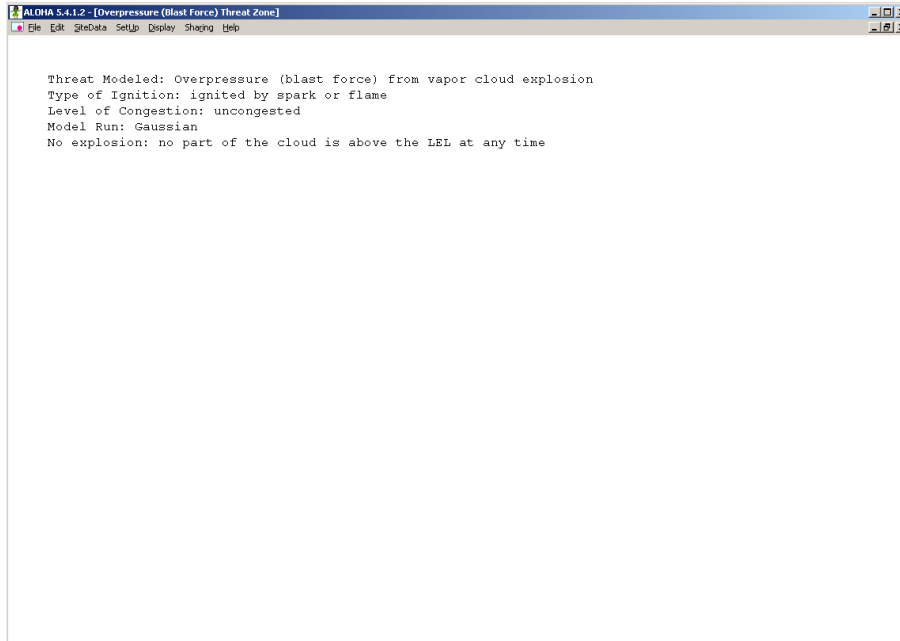

Note: ALOHA predicts there will not be any explosion from an ACETONE release with these conditions because the LEL for Acetone is never exceeded.

SOURCE STRENGTH:

Leak from short pipe or valve in horizontal cylindrical tank

Flammable chemical escaping from tank (not burning)

Tank Diameter: 9.72 feet Tank Length: 54 feet

Tank Volume: 30000 gallons

Tank contains liquid Internal Temperature: 35° F

Chemical Mass in Tank: 172,918 pounds

Tank is 85% full

Circular Opening Diameter: 3 inches

Opening is 0 feet from tank bottom

Ground Type: Default soil

Ground Temperature: equal to ambient

Max Puddle Diameter: Unknown

Release Duration: ALOHA limited the duration to 1 hour

Max Average Sustained Release Rate: 327 pounds/min

(averaged over a minute or more)

Total Amount Released: 13,653 pounds

Note: The chemical escaped as a liquid and formed an evaporating puddle.

The puddle spread to a diameter of 50 yards.

THREAT ZONE:

Threat Modeled: Overpressure (blast force) from vapor cloud explosion

Type of Ignition: ignited by spark or flame

Level of Congestion: uncongested

Model Run: Gaussian

No explosion: no part of the cloud is above the LEL at any time

TOXIC THREAT ZONE AREA

Using a 3-inch short pipe or valve located at the bottom of the tank

1. Select the Display / Threat Zone menu
2. Select “Toxic Area of Vapor Cloud” as the Hazard to Analyze

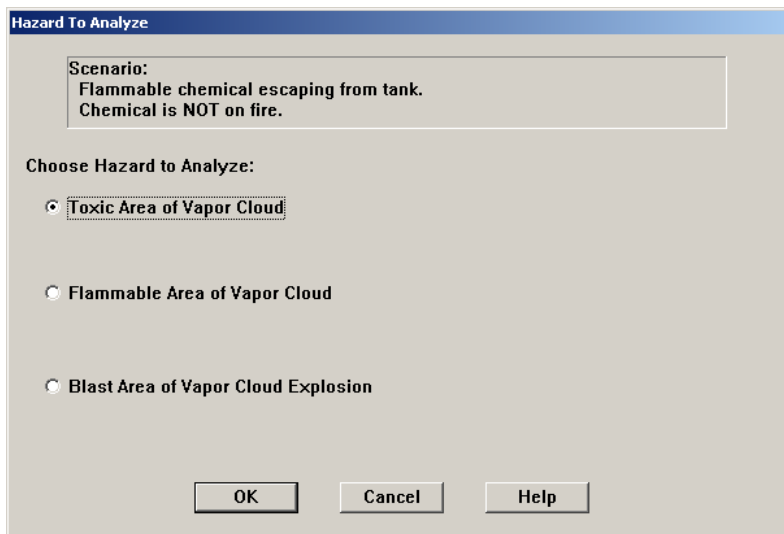

3. Accept the ALOHA default values for the Level of Concern

Toxic Level of Concern

Select Toxic Level of Concern:

Red Threat Zone
LOC: **TEEL-3: 5700 ppm**

Orange Threat Zone
LOC: **TEEL-2: 3200 ppm**

Yellow Threat Zone
LOC: **TEEL-1: 200 ppm**

Show confidence lines:
 only for longest threat zone
 for each threat zone

OK Cancel Help

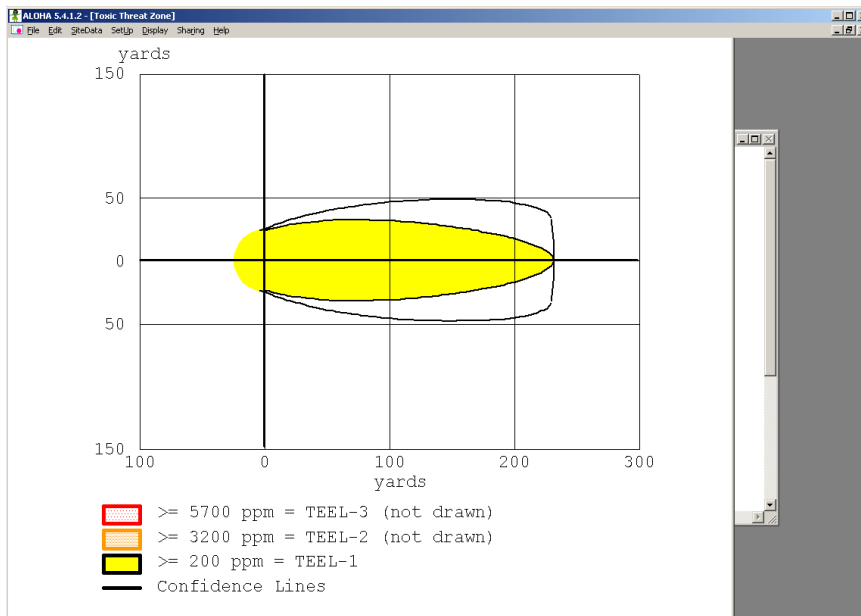

SOURCE STRENGTH:

Leak from short pipe or valve in horizontal cylindrical tank
Flammable chemical escaping from tank (not burning)
Tank Diameter: 9.72 feet Tank Length: 54 feet
Tank Volume: 30000 gallons
Tank contains liquid Internal Temperature: 35° F
Chemical Mass in Tank: 172,918 pounds
Tank is 85% full
Circular Opening Diameter: 3 inches
Opening is 0 feet from tank bottom
Ground Type: Default soil
Ground Temperature: equal to ambient
Max Puddle Diameter: Unknown
Release Duration: ALOHA limited the duration to 1 hour
Max Average Sustained Release Rate: 327 pounds/min
(averaged over a minute or more)
Total Amount Released: 13,653 pounds
Note: The chemical escaped as a liquid and formed an evaporating puddle.
The puddle spread to a diameter of 50 yards.

THREAT ZONE:

Model Run: Gaussian
Red : 24 yards --- (5700 ppm = TEEL-3)
Note: Threat zone was not drawn because effects of near-field patchiness
make dispersion predictions less reliable for short distances.
Orange: 29 yards --- (3200 ppm = TEEL-2)
Note: Threat zone was not drawn because effects of near-field patchiness
make dispersion predictions less reliable for short distances.
Yellow: 232 yards --- (200 ppm = TEEL-1)

REPEAT THE ABOVE STEPS USING CHEMICAL "CYCLOHEXYLAMINE"

BLEVE THREAT ZONE: CYCLOHEXYLAMINE

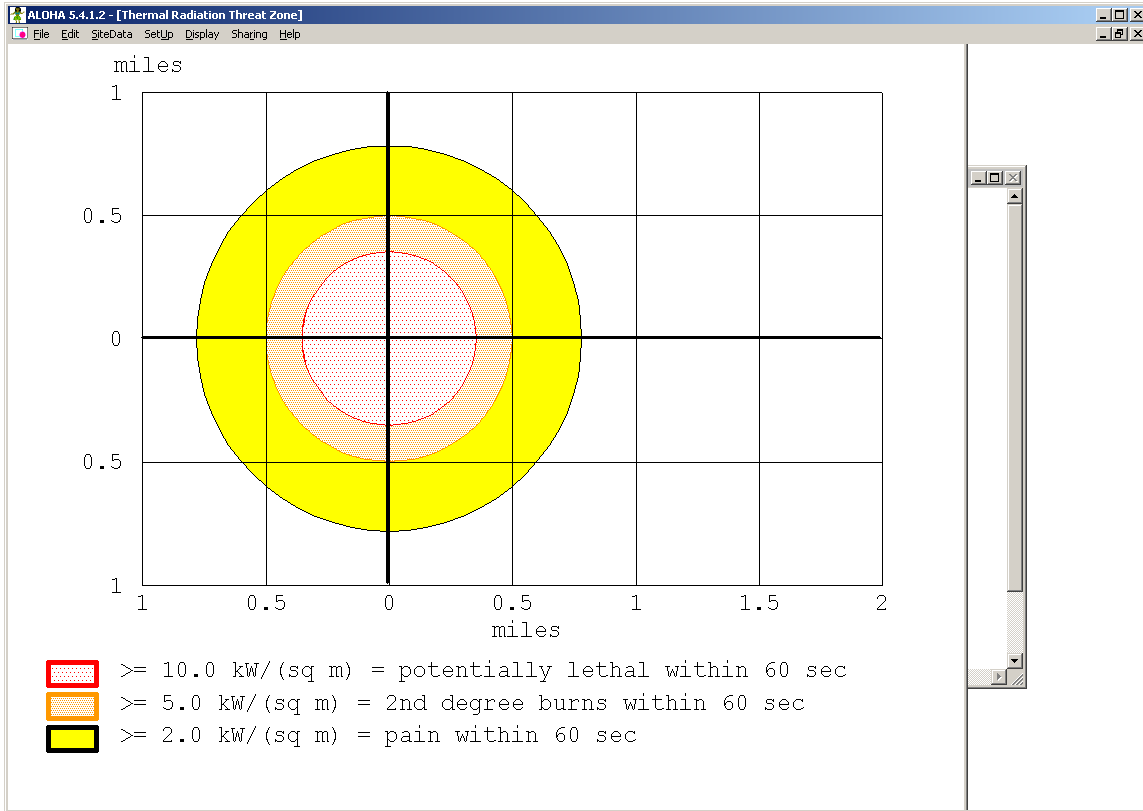

SITE DATA:

Location: OKLAHOMA CITY, OKLAHOMA

Building Air Exchanges Per Hour: 1.26 (unsheltered single storied)

Time: December 1, 2010 0630 hours CST (user specified)

CHEMICAL DATA:

Chemical Name: CYCLOHEXYLAMINE Molecular Weight: 99.17 g/mol

AEGL-1(60 min): 1.8 ppm AEGL-2(60 min): 8.6 ppm AEGL-3(60 min): 30 ppm

LEL: 6600 ppm UEL: 93000 ppm

Ambient Boiling Point: 270.7° F

Vapor Pressure at Ambient Temperature: 0.0030 atm

Ambient Saturation Concentration: 3,130 ppm or 0.31%

ATMOSPHERIC DATA: (MANUAL INPUT OF DATA)

Wind: 16 miles/hour from sw at 10 meters

Ground Roughness: open country Cloud Cover: 0 tenths

Air Temperature: 35° F Stability Class: D

No Inversion Height Relative Humidity: 22%

SOURCE STRENGTH:

BLEVE of flammable liquid in horizontal cylindrical tank

Tank Diameter: 9.72 feet Tank Length: 54 feet

Tank Volume: 30000 gallons

Tank contains liquid
Internal Storage Temperature: 35° F
Chemical Mass in Tank: 187,668 pounds
Tank is 85% full
Percentage of Tank Mass in Fireball: 100%
Fireball Diameter: 279 yards Burn Duration: 15 seconds

THREAT ZONE:

Threat Modeled: Thermal radiation from fireball
Red: 620 yards --- (10.0 kW/(sq m) = potentially lethal within 60 sec)
Orange: 878 yards --- (5.0 kW/ (sq m) = 2nd degree burns within 60 sec)
Yellow: 1375 yards --- (2.0 kW/ (sq m) = pain within 60 sec)

VAPOR CLOUD EXPLOSION THREAT ZONE: CYCLOHEXYLAMINE

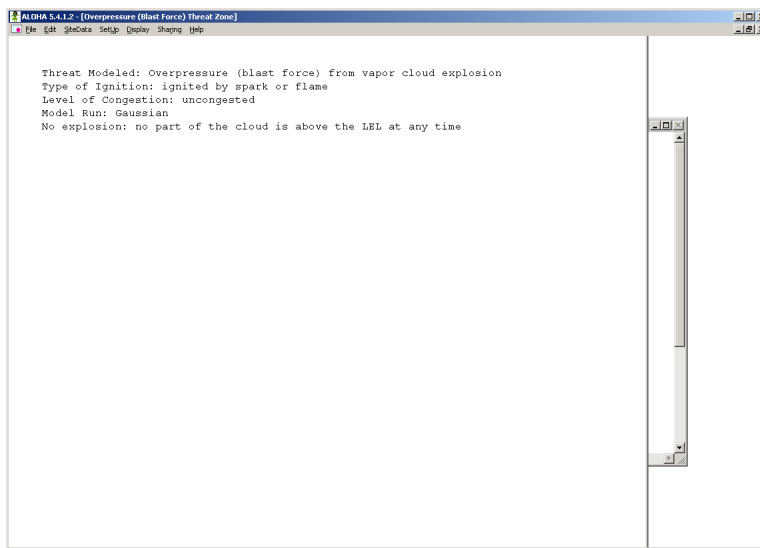

TOXIC AREA THREAT ZONE: CYCLOHEXYLAMINE

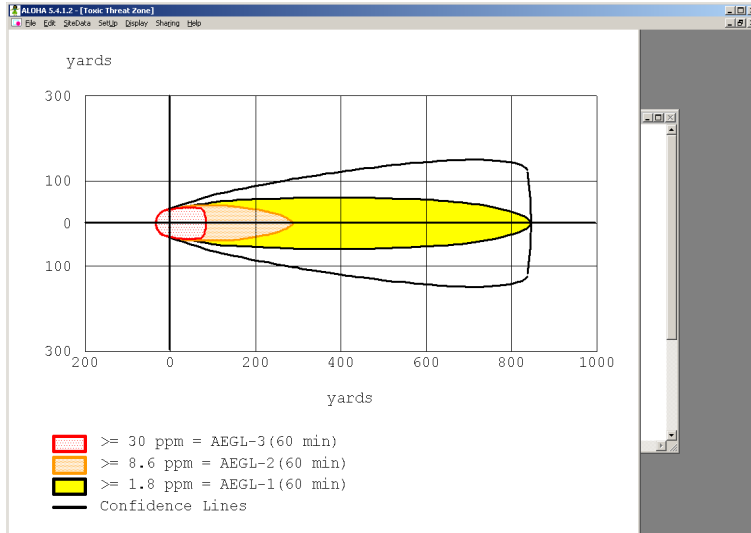

SITE DATA:

Location: OKLAHOMA CITY, OKLAHOMA
Building Air Exchanges Per Hour: 1.26 (unsheltered single storied)
Time: December 1, 2010 0630 hours CST (user specified)

CHEMICAL DATA:

Chemical Name: CYCLOHEXYLAMINE Molecular Weight: 99.17 g/mol
AEGL-1(60 min): 1.8 ppm AEGL-2(60 min): 8.6 ppm AEGL-3(60 min): 30 ppm
LEL: 6600 ppm UEL: 93000 ppm
Ambient Boiling Point: 270.7° F
Vapor Pressure at Ambient Temperature: 0.0030 atm
Ambient Saturation Concentration: 3,130 ppm or 0.31%

ATMOSPHERIC DATA: (MANUAL INPUT OF DATA)

Wind: 16 miles/hour from SW at 10 meters
Ground Roughness: open country Cloud Cover: 0 tenths
Air Temperature: 35° F Stability Class: D
No Inversion Height Relative Humidity: 22%

SOURCE STRENGTH:

Leak from short pipe or valve in horizontal cylindrical tank
Flammable chemical escaping from tank (not burning)
Tank Diameter: 9.72 feet Tank Length: 54 feet
Tank Volume: 30000 gallons
Tank contains liquid Internal Temperature: 35° F
Chemical Mass in Tank: 187,668 pounds
Tank is 85% full
Circular Opening Diameter: 3 inches
Opening is 0 feet from tank bottom

Ground Type: Default soil
Ground Temperature: equal to ambient
Max Puddle Diameter: Unknown
Release Duration: ALOHA limited the duration to 1 hour
Max Average Sustained Release Rate: 37.3 pounds/min
(averaged over a minute or more)
Total Amount Released: 1,285 pounds
Note: The chemical escaped as a liquid and formed an evaporating puddle.
The puddle spread to a diameter of 66 yards.

THREAT ZONE:

Model Run: Gaussian
Red: 84 yards --- (30 ppm = AEGL-3(60 min))
Orange: 288 yards --- (8.6 ppm = AEGL-2(60 min))
Yellow: 847 yards --- (1.8 ppm = AEGL-1(60 min))

REPEAT THE ABOVE STEPS USING CHEMICAL “HYDROCHLORIC ACID, SOLUTION”

1. Select the Setup / Chemical menu
2. Select “Solutions”

Chemical Information

View: Pure Chemicals
 Solutions

AQUEOUS AMMONIA
HYDROCHLORIC ACID
HYDROFLUORIC ACID
NITRIC ACID
OLEUM

Solution Strength: % (by Weight)

The percentage of ammonia in solution.
Allowable range is 0 to 30 percent.

Select
Cancel
Help

3. Select “Hydrochloric Acid” and enter “42” % (by Weight)

Chemical Information

View: Pure Chemicals
 Solutions

AQUEOUS AMMONIA
HYDROCHLORIC ACID
HYDROFLUORIC ACID
NITRIC ACID
OLEUM

Solution Strength: 42 % (by Weight)

The percentage of hydrogen chloride in
solution. Allowable range is 20 to 42 percent.

Select
Cancel
Help

4. Select the Setup / Source / Puddle menu
5. Enter diameter = 170 yards and Volume = 25,500 gallons (which is 85% of the 30,000-gallon tank capacity)

Puddle Input

Puddle area diameter is: feet yards meters

Select one and enter appropriate data

Volume of puddle
 Average depth of puddle
 Mass of puddle

Volume is: gallons liters
 cubic feet cubic meters

6. Select “Default”; “Air Temp”; and “Ground Temp”

Ground Type, Ground and Puddle Temperature

Select ground type

Default soil [select this if unknown]
 Concrete
 Sandy dry soil
 Moist sandy soil
 Water [ALOHA does not model solutions on water]

Input ground temperature

Use air temperature [select this if unknown]
 Ground temperature is F C

Input initial puddle temperature

Use ground temperature [select this if unknown]
 Use air temperature
 Initial puddle temperature is F C

7. Select the Display / Threat Zone menu

Toxic Level of Concern

Select Toxic Level of Concern:

Red Threat Zone
LOC: **AEGL-3(60 min): 100 ppm**

Orange Threat Zone
LOC: **AEGL-2(60 min): 22 ppm**

Yellow Threat Zone
LOC: **AEGL-1(60 min): 1.8 ppm**

Show confidence lines:
 only for longest threat zone
 for each threat zone

OK Cancel Help

8. Accept the ALOHA default values for the Level of Concern

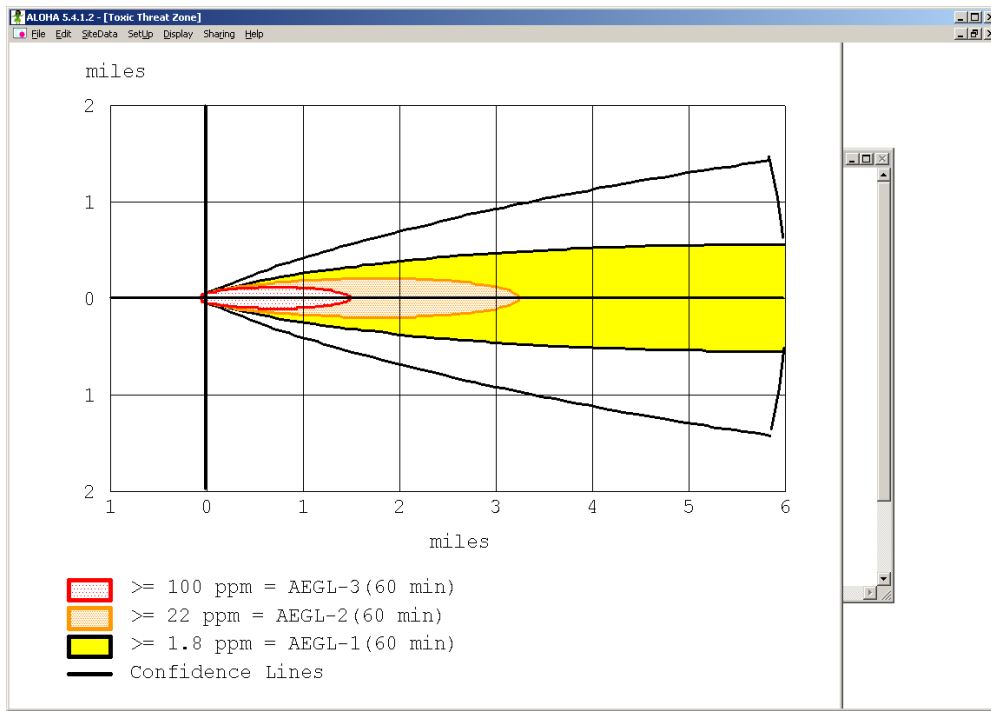

SITE DATA:

Location: OKLAHOMA CITY, OKLAHOMA
Building Air Exchanges Per Hour: 1.26 (unsheltered single storied)
Time: December 1, 2010 0630 hours CST (user specified)

CHEMICAL DATA:

Chemical Name: HYDROCHLORIC ACID
Solution Strength: 42% (by weight)
Ambient Boiling Point: 68.9° F
Partial Pressure at Ambient Temperature: 0.36 atm
Ambient Saturation Concentration: 381,055 ppm or 38.1%
Hazardous Component: HYDROGEN CHLORIDE
Molecular Weight: 36.46 g/mol
AEGL-1(60 min): 1.8 ppm AEGL-2(60 min): 22 ppm AEGL-3(60 min): 100 ppm
IDLH: 50 ppm

ATMOSPHERIC DATA: (MANUAL INPUT OF DATA)

Wind: 16 miles/hour from sw at 10 meters
Ground Roughness: open country Cloud Cover: 0 tenths
Air Temperature: 35° F Stability Class: D
No Inversion Height Relative Humidity: 22%

SOURCE STRENGTH:

Evaporating Puddle
Puddle Diameter: 170 yards Puddle Volume: 25500 gallons
Ground Type: Default soil Ground Temperature: 35° F
Initial Puddle Temperature: Ground temperature
Release Duration: ALOHA limited the duration to 1 hour
Max Average Sustained Release Rate: 8,090 pounds/min
(averaged over a minute or more)
Total Amount Hazardous Component Released: 42,025 pounds

THREAT ZONE:

Model Run: Gaussian
Red: 1.5 miles --- (100 ppm = AEGL-3(60 min))
Orange: 3.3 miles --- (22 ppm = AEGL-2(60 min))
Yellow: greater than 6 miles --- (1.8 ppm = AEGL-1(60 min))

Notice ALOHA does not offer either "BLEVE" or "Vapor Cloud Explosion" as hazard to Analyze choices for the Hydrochloric Acid. However, the Toxic Threat Zone Area for the Hydrochloric is very large when compared to the Threat Zones for Cyclohexylamine and Acetone.

Notice that for all three chemicals, ALOHA predicts the length of time for the liquid to completely volatilize is greater than one hour. You can find this by reviewing the SOURCE STRENGTH part of the ALOHA Text Summary.

ACETONE:

SOURCE STRENGTH:

Leak from short pipe or valve in horizontal cylindrical tank

Flammable chemical escaping from tank (not burning)

Tank Diameter: 9.72 feet Tank Length: 54 feet

Tank Volume: 30000 gallons

Tank contains liquid Internal Temperature: 35° F

Chemical Mass in Tank: 172,918 pounds

Tank is 85% full

Circular Opening Diameter: 3 inches

Opening is 0 feet from tank bottom

Ground Type: Default soil

Ground Temperature: equal to ambient

Max Puddle Diameter: Unknown

Release Duration: **ALOHA limited the duration to 1 hour**

Max Average Sustained Release Rate: 327 pounds/min

(averaged over a minute or more)

Total Amount Released: **13,653 pounds**

Note: The chemical escaped as a liquid and formed an evaporating puddle.

The puddle spread to a diameter of 50 yards.

CYCLOHEXYLAMINE:

SOURCE STRENGTH:

Leak from short pipe or valve in horizontal cylindrical tank

Flammable chemical escaping from tank (not burning)

Tank Diameter: 9.72 feet Tank Length: 54 feet

Tank Volume: 30000 gallons

Tank contains liquid Internal Temperature: 35° F

Chemical Mass in Tank: 187,668 pounds

Tank is 85% full

Circular Opening Diameter: 3 inches

Opening is 0 feet from tank bottom

Ground Type: Default soil

Ground Temperature: equal to ambient

Max Puddle Diameter: Unknown

Release Duration: **ALOHA limited the duration to 1 hour**

Max Average Sustained Release Rate: 37.3 pounds/min

(averaged over a minute or more)

Total Amount Released: **1,285 pounds**

Note: The chemical escaped as a liquid and formed an evaporating puddle.

The puddle spread to a diameter of 66 yards.

HYDROCHLORIC ACID:

SOURCE STRENGTH:

Evaporating Puddle

Puddle Diameter: 170 yards

Puddle Volume: 25500 gallons

Ground Type: Default soil

Ground Temperature: 35° F

Initial Puddle Temperature: Ground temperature

Release Duration: ALOHA **limited the duration to 1 hour**

Max Average Sustained Release Rate: 8,090 pounds/min

(averaged over a minute or more)

Total Amount Hazardous Component Released: **42,025 pounds**

Notice the amount of Hydrochloric Acid release during the first hour compared to the Cyclohexylamine and the Acetone

ACETONE:

Total Amount Released: 13,653 pounds

CYCLOHEXYLAMNE:

Total Amount Released: 1,285 pounds

HYDROCHLORIC ACID:

Total Amount Hazardous Component Released: 42,025 pounds

Notice ALOHA does not allow us to use the “tank” source model for any of the chemical “solutions”. Thus, the amount of time needed for the Hydrochloric to exit the railcar is not considered by ALOHA. ALOHA modeled the Hydrochloric as if it were as instantaneously formed “puddle” that is 170 yards in diameter.

To effectively compare the volatilization rate of the Acetone and the Cyclohexylamine to the Hydrochloric Acid, users would need to use the “puddle” model for all three materials. However, using the puddle model ignores the time necessary for the material to vacate the tanker via a 3” valve leak. Thus, the ALOHA results for the Acetone and the Cyclohexylamine will likely be more accurate using the Tank course model.

In any case, ALOHA provides additional information that may be critical to a safe and effective response to this derailment event. Incident Command should be appraised of the potential BLEVE area and the Toxic Threat Zone areas. The ERG-suggested Isolation Zone of 150 feet may not offer sufficient protective distances in this case.

Additionally, one should consider modeling all the above release scenarios using the forecasted weather. The fact that the temperature is going to be 55 degrees rather than 35 degrees may significantly alter the ALOHA Threat Zone predictions. And the wind direction and speed will be changing, too. Remember, no chemical release is occurring at 6:30 am, and we are using ALOHA to evaluate what might happen. As such, we should consider future weather conditions in our ALOHA analyses.

ANSWERS:

UN # 1789	Hydrochloric Acid, Solution
UN # 2428	Sodium Chlorate, Aqueous Solution
Acetone	Acetone
CAS # 108-91-8	Cyclohexylamine

CAMEO Chemicals

1. Use CAMEO Chemicals to gather information for the various chemicals. (CAMEO Companion pages 31-34)
 - a. Are these materials liquid, solid, or gas? **ALL ARE LIQUIDS**
 - b. Is it likely that these materials are carried in Liquid Tankers or Pressurized Tankers? **ALL WOULD LIKELY SHIP IN LIQUID TANKERS**
 - c. What are the primary hazards associated with these materials?
ACETONE: FLAMMABLE
HYDROCHLORIC ACID: REACTIVE AND TOXIC
CYCLOHEXYLAMINE: TOXIC AND FLAMMABLE
SODIUM CHLORATE: OXIDIZER

2. Use the CAMEO Chemicals “Predict Reactivity” module to evaluate the potential reactive hazards for this incident. (CAMEO Companion pages 34-35)

	CYCLOHEXYLAMINE		
HYDROCHLORIC ACID, SOLUTION	Corrosive Heat generation Intense reaction Toxic gas	HYDROCHLORIC ACID, SOLUTION	
SODIUM CHLORATE, AQUEOUS SOLUTION	Corrosive Explosive Flammable Flammable gas Heat generation Toxic gas	Combustion-enhancing gas Corrosive Explosive Flammable Heat generation Intense reaction Toxic gas	SODIUM CHLORATE, AQUEOUS SOLUTION
ACETONE	Flammable gas	Heat generation	Explosive Flammable Heat generation Intense reaction Toxic Toxic gas

3. Determine the Initial Isolation Zone and Evacuation distances appropriate for this scenario. (CAMEO Companion pages 31-34) ERG **SUGGESTS 150 IMMEDIATE ISOLATION ZONE FOR ALL FOUR OF THESE SUBSTANCES. EVACUATION DISTANCES VARY FROM 100 FEET TO 1000 FEET (NON-FIRE); AND ½ MILE (FIRE)**