

- 8¹ BZ Hand Tools for Blind Rivets**
- 8² VNG Hand Tools for Blind Rivet Nuts and Blind Rivet Bolts**
- 8³ MULTI Hand Tools for Blind Rivets, Blind Rivet Nuts and Blind Rivet Bolts**
- 8⁴ Miscellaneous Tools**



8 1

BZ 2

Hand Tool for Blind Rivets
with opening spring

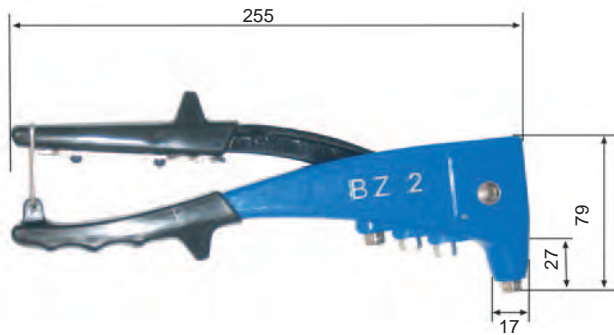

Good Ergonomics, Brilliant Transformation

	2,4	3,0	3,2	4,0	4,8	5,0	6,0	6,4	8,0
	Aluminium								
	Steel								
	Stainless steel								
	Copper alloys								
	0,56 kg		STROKE 8 mm		Blister		Incl. 4 nosepieces		
Special nosepieces ▶ page138									

No. 310.002.000.000

BZ 44

Hand Tool for Blind Rivets
with opening spring

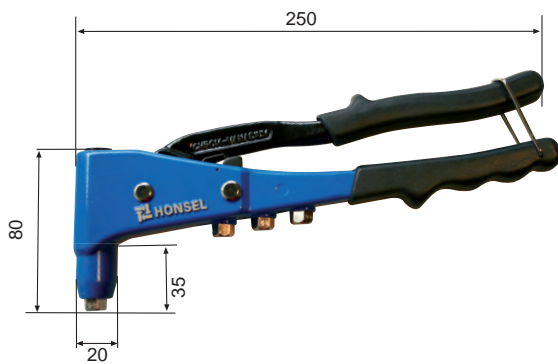

Classic Tool - Robust and Reliable

	2,4	3,0	3,2	4,0	4,8	5,0	6,0	6,4	8,0
	optional Aluminium								
	Steel								
	Stainless steel								
	Copper alloys								
	0,63 kg		STROKE 9,5mm		Blister		Incl. 3 nosepieces		
Special nosepieces ▶ page138									

No. 310.044.000.000





Hand Tools for Blind Rivets

NEW + OPTIMIZED
Available from ab September 2011

BZ 70 Lever Tool

	2,4	3,0	3,2	4,0	4,8	5,0	6,0	6,4	8,0
	Aluminium								
	Steel								
	Stainless steel								
	Copper alloys								
	1,5 kg		STROKE 14,5mm		plastic case		Incl. 4 nosepieces		
	Special nosepieces on request						max. mandrel- \varnothing 3,2 mm		

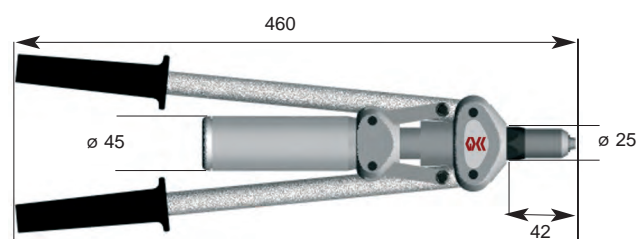

No. 310.070.000.000

Illustration similar to original product

NEW + OPTIMIZED
Available from ab September 2011

BZ 72 Lever Tool

	2,4	3,0	3,2	4,0	4,8	5,0	6,0	6,4	8,0
	Aluminium								
	Steel								
	Stainless steel								
	Copper alloys								
	1,65 kg		STROKE 14,5mm		plastic case		Incl. 5 nosepieces		
	Special nosepieces on request						max. mandrel- \varnothing 4,0 mm		

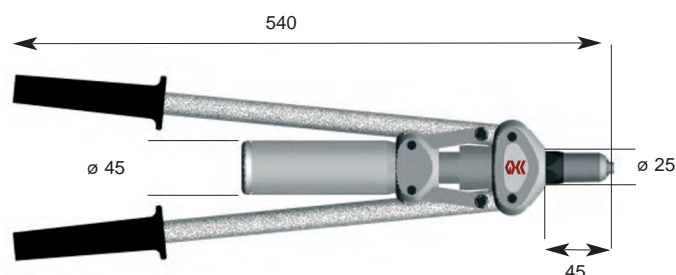

No. 310.072.000.000

Illustration similar to original product

Manual handling of high strength rivets on request.

	2,4	3,0	3,2	4,0	4,8	5,0	6,0	6,4	8,0
	Aluminium								
	Steel								
	Stainless steel								
	Copper alloys								
	2,0 kg		STROKE 11 mm		carton		Incl. 4 nosepieces		
	Special nosepieces on request						max. mandrel \varnothing 3,8 mm		

BZ 58 Sheare Tool

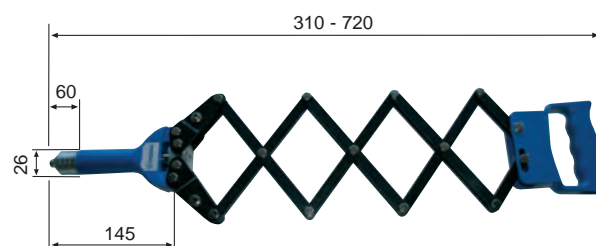

No. 310.058.000.000



8 2

VNG 255

Hand Tool with Assortment

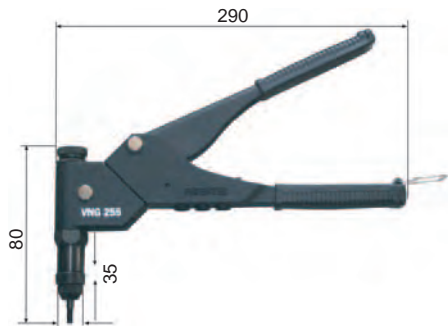

	M3	M4	M5	M6	M8	M10	M12	
		Aluminium						
		Steel						
		Stainless steel						
		Steel						
	0,9 kg		plastic case		case size 325 x 250 x 50 mm			
content				assortment				
<ul style="list-style-type: none"> • each with 1 piece conversation kit for blind rivet nuts M4, M5, M6; • each with 1 piece threaded sleeve for blind rivet bolts M4, M5, • each with 1 piece jaw wrench AF 22, AF 24, • 1 piece hex head wrench AF 6 				<ul style="list-style-type: none"> • 25 pieces each blind rivet nuts Universal M4, M5; • 50 pieces blind rivet nuts Universal M6; • 25 pieces each blind rivet bolts M4x2010 and M5x2010 				
continuous pivotable about 360°								

No. 310.255.000.000

Possible positions to work

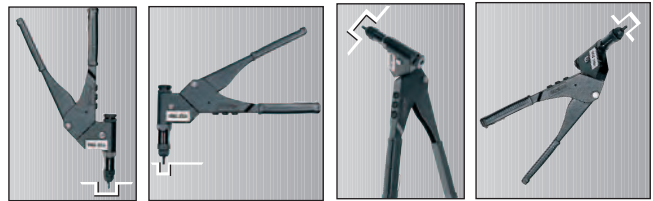

VNG 371

Lever tool

NEW + OPTIMIZED
Available from ab September 2011

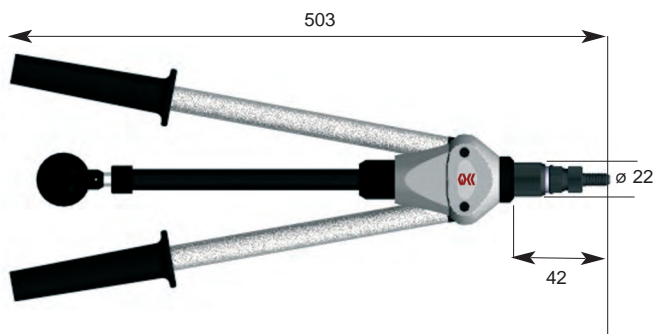

Illustration similar to original product

	M3	M4	M5	M6	M8	M10	M12	
			Aluminium					
			Steel					
			Stainless steel					
			Steel					
	1,2 kg		plastic case					
content								
<ul style="list-style-type: none"> • each with 1 piece conversation kit for blind rivet nuts M5 - M 10 • each with 1 piece threaded sleeve for blind rivet bolts M5 - M8 • each with 1 piece jaw wrench AF 10, AF 14, • 1 piece hex head wrench AF 6 								

No. 310.371.000.000



VNG 612 Hand Tool

	M3	M4	M5	M6	M8	M10	M12
		optional		Aluminium			
		optional		Steel			
		optional		Stainless steel			
			Steel				
	1,1 kg		case in aluminium optics		Case size 370 x 290 x 70 mm		
content each with 1 piece conversation kit for blind rivet nuts M6-M12; each with 1 piece threaded sleeve for blind rivet bolts M5-M8,				Conversation kit available separately ▶ page 137			

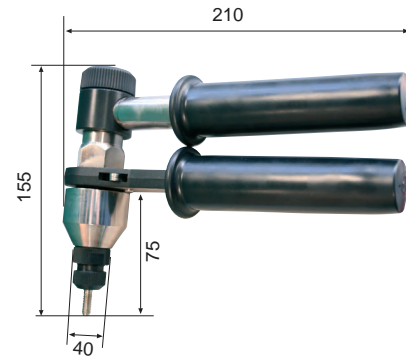

No. 310.612.000.000



Available from September 2011

	M3	M4	M5	M6	M8	M10	M12
	Aluminium						
	Steel						
	Stainless steel						
		Steel					
	plastic case			case size 290 x 195 x 54 mm			
	0,6 kg		with hydraulic component				
Content • each with 1 piece conversation kit for blind rivet nuts M3-M8 • each with 1 piece conversation kit for blind rivet bolts M4-M8,							

VNG 152 Hand Tool with hydraulic assistance

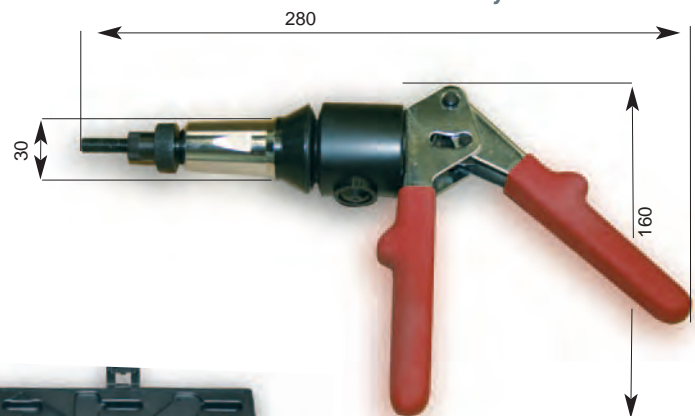

VNG hand tools

No. 310.152.000.000





8 3

Multi 1

Hand Tool for Blind Rivets, Blind Rivet Nuts and Blind Rivet Bolts

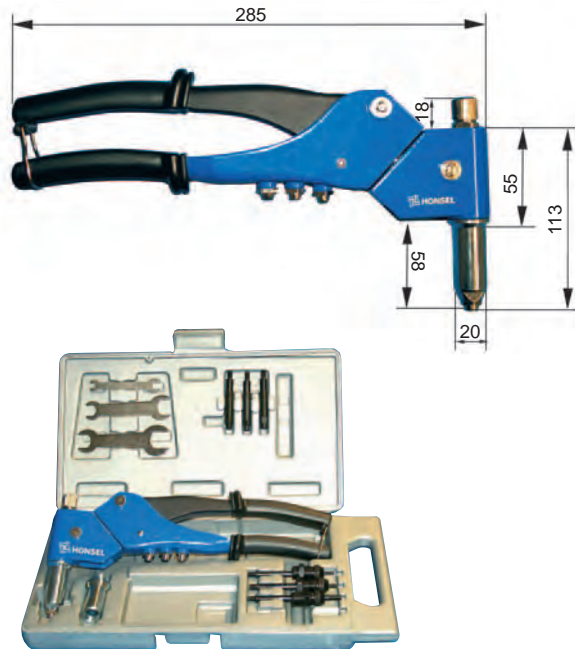

	2,4	3,0	3,2	4,0	4,8	5,0	6,0	6,4
	Aluminium							
	Steel							
	Stainless steel							
	Copper alloys							

	M3	M4	M5	M6	M8	M10	M12
	Aluminium						
	Steel						
		Steel					

plastic case case size 360 x 185 x 50 mm
 0,56 kg continuous pivotable about 360°
Content
 • each with 1 nosepiece for blind rivets 2,4; 3,0/3,2mm; 4,0 mm; 4,8/5,0mm
 • each with 1 piece conversation kit for blind rivet nuts M3-M6
 • each with 1 piece threaded sleeve for blind rivet bolts M4-M6,
 • each with 1 piece jaw wrench AF 15/19, AF 21/17.AF 58

No. 310.100.000.000

Multi 5

Lever Tool for Blind Rivets, Blind Rivet Nuts and Blind Rivet Bolts

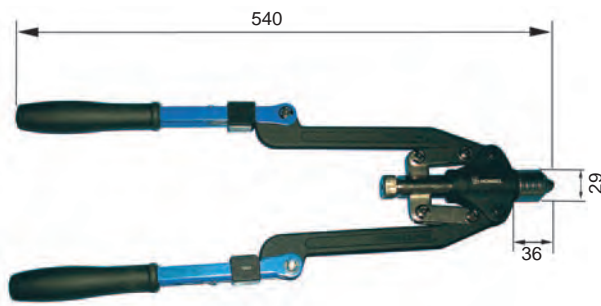

	2,4	3,0	3,2	4,0	4,8	5,0	6,0	6,4
	Aluminium							
	Steel							
	Stainless steel							
	Copper alloys							

	M3	M4	M5	M6	M8	M10	M12
	Aluminium						
	Steel						
		Steel					

plastic case case size 385x 240 x 55 mm
 1,9 kg fold-away handle bars
Content
 • each with 1 nosepiece for blind rivets 3,0/3,2mm; 4,0mm; 4,8/5,0mm; 6,0mm; 6,4mm
 • each with 1 piece conversation kit for blind rivet nuts M4-M10
 • each with 1 piece threaded sleeve for blind rivet bolts M4-M8,
 • each with 1 piece jaw wrench AF 15/19, AF 21/17.AF 58

No. 310.500.000.000

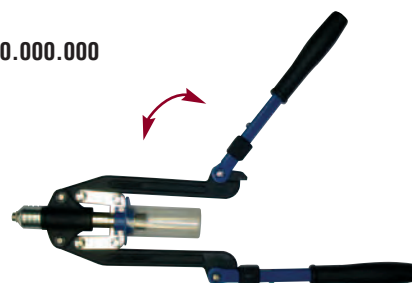

MULTI Hand Tools



VNG 150 is now MULTI 151.
 Besides its outstanding positive properties in setting blind rivet nuts, this tool is able to operate blind rivets as well.

	2,4	3,0	3,2	4,0	4,8	5,0	6,0	6,4
	Aluminium							
	Steel							
	Stainless steel							
	Copper alloys							

	M3	M4	M5	M6	M8	M10	M12	
	Aluminium							
	Steel							
	Stainless steel							
	Steel							

plastic case **case size** 290 x 195 x 54 mm
 0,6 kg **with hydraulic component**

Content
 • each with 1 nosepiece for blind rivets 3,0/3,2mm; 4,0mm; 4,8/5,0mm; 6,0mm; 6,4mm
 • each with 1 piece conversation kit for blind rivet nuts M3-M8
 • each with 1 piece conversation kit for blind rivet bolts M4-M8,

No. 310.151.000.000

Multi 151 Hand Tool for Blind Rivet Nuts, Blind Rivet Bolts and Blind Rivets with hydraulic assistance

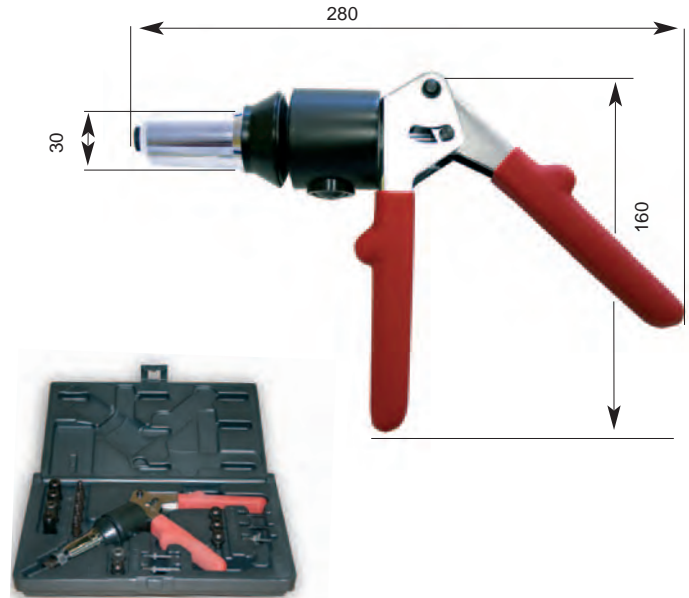

Rivet Cracker



Do not try to open rivets by screwing or carving any longer.
 This tool "bites" off the rivet heads after removing the mandrel without damaging the component.

	2,4	3,0	3,2	4,0	4,8	5,0	6,0	6,4
	Aluminium							
	Steel							

	M3	M4	M5	M6	M8	M10	M12	
	Aluminium							
	Steel							
Length 360 mm		Cutting hardness: 58 Rockwell						

	2,4	3,0	3,2	4,0	4,8	5,0	6,0	6,4
	Aluminium							

	M3	M4	M5	M6	M8	M10	M12	
	Aluminium							
	Steel							
Length 200 mm		Cutting hardness: 58 Rockwell						

Removal of Rivet Heads Easy Release of Blind Rivets and Blind Rivet Nuts



No. 310.880.100.000



No. 310.881.300.000

MULTI Tools / Rivet Cracker



8 4

Setting of Industrial Rivets

There are many different possibilities to handle industrial rivets.

- manual deformation by using riveting dies
- hand tools or toggle presses
- special machines according to customers request

DIN 6435 made from hexagon steel savy tempering, shaft equally hardened; delivered in plastic holder



Set for rivet head setting
No.18.509.000.002

Set for rivet head pulling
No. 18.509.000.001

Scope of delivery each : 5 rivet-dies 2,0 - 3,0 - 4,0 - 5,0 and 6,0 mm ø

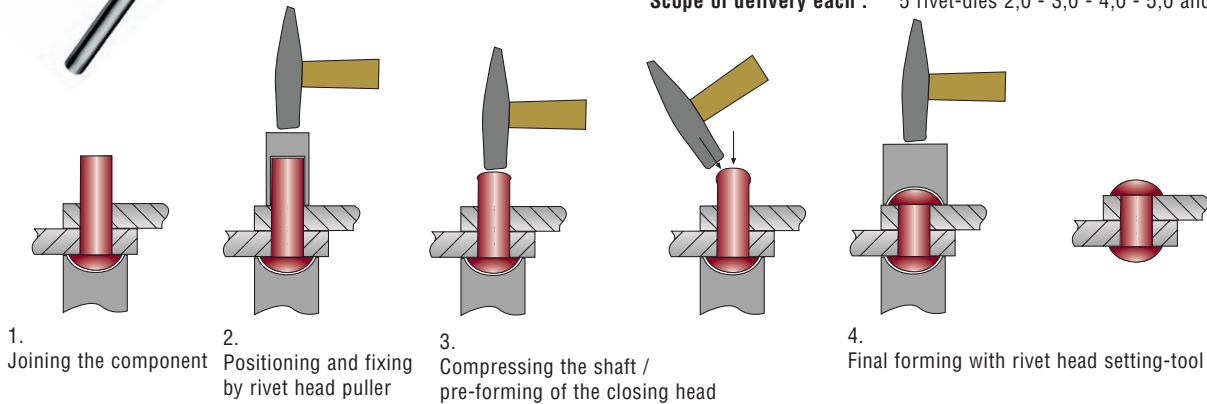

8 3

Setting of Axial Clamps

Fix our axial clamps with this compatible tool – quick and safe.

Misc. Tools

FOR AXIAL CLAMP RINGS

outside-ø	No.
15,0 mm	18.509.000.150
18,0 mm	18.509.000.180
25,0 mm	18.509.000.250

FOR AXIAL CLAMP CAPS

Outside-ø	No.
12,0 mm	18.509.000.120
16,0 mm	18.509.000.160
20,0 mm	18.509.000.200
27,0 mm	18.509.000.270
30,0 mm	18.509.000.300





The **experience of decades** and **continuous improvement** made the successful HONSEL/VVG tools of the BZ- and VNG-series become reliable utilities for industrial volume productions as well as for specialist shops and handcraft.

The **sturdy construction** and **complete equipment** with all necessary conversation parts plus **comprehensive accessories** up to **process controlled automation systems** leave nothing to be desired.

Latest development “**designed by Honsel**” is the modern type battery tool “**Rivdom**” on ► [page 129](#).

9 ¹ **Pneumatic-Hydraulic Tools for Blind Rivets (BZ-Series)**

9 ² **Battery Tool for Blind Rivets (Rivdom)**

9 ³ **Pneumatic-Hydraulic tools for Blind Rivet Nuts and Blind Rivet Bolts (VNG-Series)**



9 1

Pneumatic-Hydraulic Tools for Blind Rivets

BZ 103 A

Pneumatic-Hydraulic Tool
with permanent and intervall
mandrel exhaustion



Thousandfold Approved – the latest
version of the standard tool for
reliable processing of blind rivets



- noise reduced
- optimized ergonomics
- new package
- all necessary spare parts included
- new instruction manual

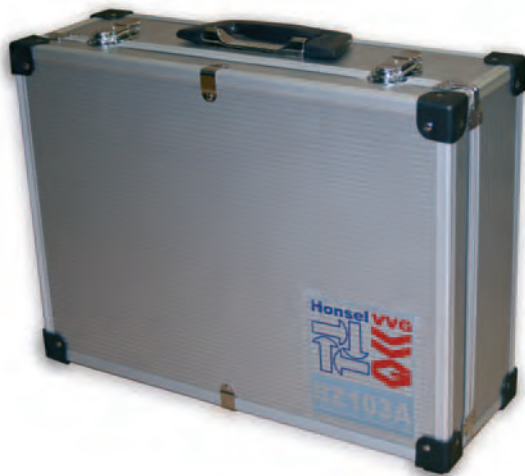

	2,4	3,0	3,2	4,0	4,8	5,0	6,0	6,4	8,0
Aluminium									
Steel									
Stainless steel									
Copper alloys									
Content	<ul style="list-style-type: none"> • 4 nosepieces • 1 set of clamping jaws • 1 bottle hydraulic oil / incl. re-fill unit • 2 mandrel collectors 						pressure: 5-7 bar	max. mandrel-ø: 3,8 mm	
							stroke : 18 mm	air consumption: 2,4 L	
							noise: < 75 dB(A) _(68,32)	working power at 7 bar: 11700 N	
							1,8 kg	hose connection: G 1/4 inside, installation on left or right side	
special accessory	▶ page 138						CE		

No. 320.103.000.000

For useful air pressure accessory take a look on ▶ page 128.

For an optimized processing of our structural FERRO®-BULB blind rivets on pages 40+41 the pneumatic-hydraulic tool BZ 133A is available on request.

This tool offers a **perfect adjustment** of the stroke (18 mm) and the working power (24.000 N) combined with adapted clamping jaws to the grooves of the mandrel. This guarantees powerful handling with reduced abrasion.





The Strong Tool - even suitable for high strength blind rivets



BZ 123 A
Pneumatic-Hydraulic Tool
with permanent and intervall
mandrel exhaustion



- noise reduced
- optimized ergonomics
- new package
- all necessary spare parts included
- new instruction manual



2,4	3,0	3,2	4,0	4,8	5,0	6,0	6,4	8,0
			Aluminium					
			Steel					
			Stainless steel					
			Copper alloys					
Content			pressure: 5-7 bar		max. mandrel-ø: 4,8 mm			
• 4 nosepieces			stroke: 25 mm		air consumption: 3,5 L			
• 1 set of clamping jaws			noise: < 75 dB(A) _(68,32)		working power at 7 bar: 18700N			
• 1 bottle hydraulic oil / incl. re-fill unit			2,34 kg		hose connection: G 1/4 inside, installation left or right side			
• 2 mandrel collectors			CE					
special accessory ▶ page 138								

No. 320.123.000.000



▶ The BZ 123A handles **high strength blind rivets** of the Honsel/ VVG series FER0-BULB and FER0-BOLT (pages 42-45) perfectly.

BZ-Series



BZ 102 / 103 Axial Pneumatic-Hydraulic Tool with permanent and intervall mandrel exhaustion



	2,4	3,0	3,2	4,0	4,8	5,0	6,0	6,4	8,0
Aluminium									
Steel									
Stainless steel									
Copper alloys									
weight	2,1 kg								
height		365 mm							
stroke			18 mm						
max. mandrel-ø				3,8 mm					
tensile force at 7 bar	11700 N								
noise			< 75 dB(A) ^(68,32)						
pressure			5-7 bar						
air consumption				2,4 litre					
content	4 nosepieces 1 re-fill unit			1 set of clamping jaws 1 mandrel collector					1 bottle hydraulic oil
hose connection	ø 1/4" inside, installation left or right side								
options	<ul style="list-style-type: none"> • balancer • mandrel conduction hose • mandrel conduction adapter • mandrel conduction box 								

The new option for axial handling with the approved pneumatic-hydraulic tools of the Honsel/VVG BZ-series.

No. 320.102.000.000/5

Rivet Angle Head for BZ Blind Rivet Tools

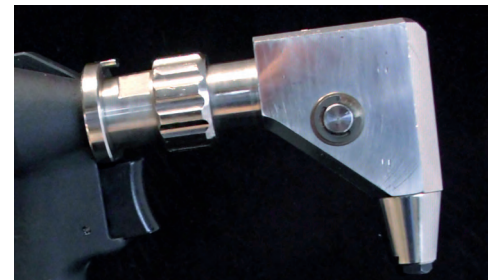
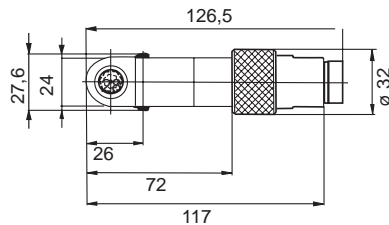

Rivet angle heads for difficult to reach positions are available on request.

No. 321.102.000.600

For optimized handling we suggest the following accessory for all HONSEL-/VVG-Tools:

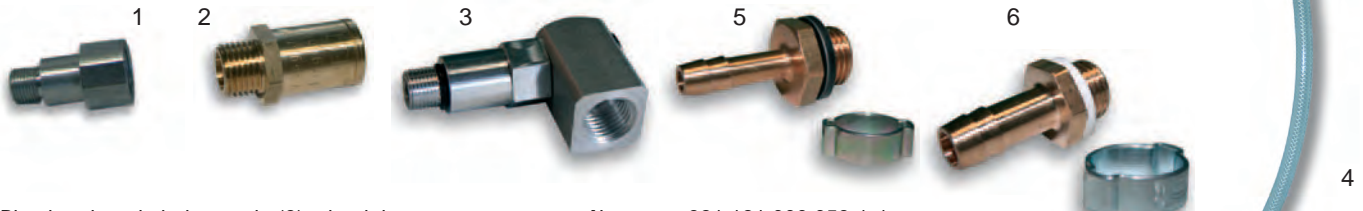

- Pivoting threaded pipe angle (3), aluminium No.: 321.121.000.053 1-1
- Pivoting threaded pipe angle (3), stainless steel No.: 321.121.000.053 2-1
- Valve extension (1) No.: 321.121.000.052 1-1
- Pressure reducing valve (2) No.: 321.000.141.360 1-1
- Pivoting threaded pipe angle (3) including fabric tube with 1/4" external thread and hose coupling (4) No.: 321.121.000.053 3-1
- Screw-in hose connector -set- G 1/4" 6 mm (5) No.: 321.121.000.057 1-1
- Screw-in hose connector -set- G 1/4" 9 mm (6) No.: 321.101.000.058 1-1

Additional connections for compressed-air available on request



For undisturbed operation Honsel-/VVG-Tools need a continuous, periodic maintenance. Make sure that for BZ-Tools clean and dry, for VVG-Tools clean and lubricated compressed air is available. We advise the use of filter pressure reducers (BZ) or compressed-air service units (VVG).

- Compressed-air service unit (Pressure reducer/ oil fog lubricator (VVG-Serie) No.: 320 847 000 000
- Pressure reducer (BZ-Series) No.: 320 848 000 000

Additional accessory as for example balancer, spiral coiled tubes or compressors are available on request. Spare parts, special nosepieces or useful special attachments are shown in ► chapter 10, pages 135 et sqq.



RIVDOM Battery Tool for Blind Rivets

THE NEW DIMENSION OF INDEPENDENT BLIND RIVET HANDLING



Note: Picture above shows Rivdom with LI-ION battery -large- (321.400.000.021)



Sturdy plastic case with metal locks in an attractive sales packaging

Battery -large-
14,4V / 3,0 Ah



Battery -standard-
14,4V / 1,5 Ah



Premium, compact
quick-charger



- LI-ION battery -standard- (14,4V / 1,5 Ah)
No. 321.400.000.020
- LI-ION battery -large- (14,4V / 3,0 Ah)
No. 321.400.000.021
- Rivdom quick-charger
No. 321.400.000.001

	2,4	3,0	3,2	4,0	4,8	5,0	6,0	6,4	8,0
Aluminium	[Color bar]								
Steel	[Color bar]								
Stainless steel	[Color bar]								
Copper alloys	[Color bar]								
content	<ul style="list-style-type: none"> • 4 nosepieces • 1 mandrel collector • 1 battery 14,4V / 1,5 Ah • 1 quick-charger 14,4V 					 1,54 kg		max. mandrel-ø: 3,4 mm	
optional	<ul style="list-style-type: none"> • battery 14,4V / 3,0 Ah 					 0,33 kg 1,5 Ah		working power: 9000 N	
						 0,53 kg 3,0 Ah		stroke: 21 mm charging time 1,5 Ah: < 1 hour	



No. 320.400.000.000

RIVDOM