

Comprehension Paper - The Book of Time

SAMPLE PAPER 1 hour 15 minutes

This is a workbook all about TIME.

You will find a collection of passages, drawings and diagrams.

There are questions in each section; please answer them in the order set.

Work at a steady pace, answering questions as fully as you can.

If you find something tricky, leave it and go on to the next question.

Do not worry if you do not finish the paper.

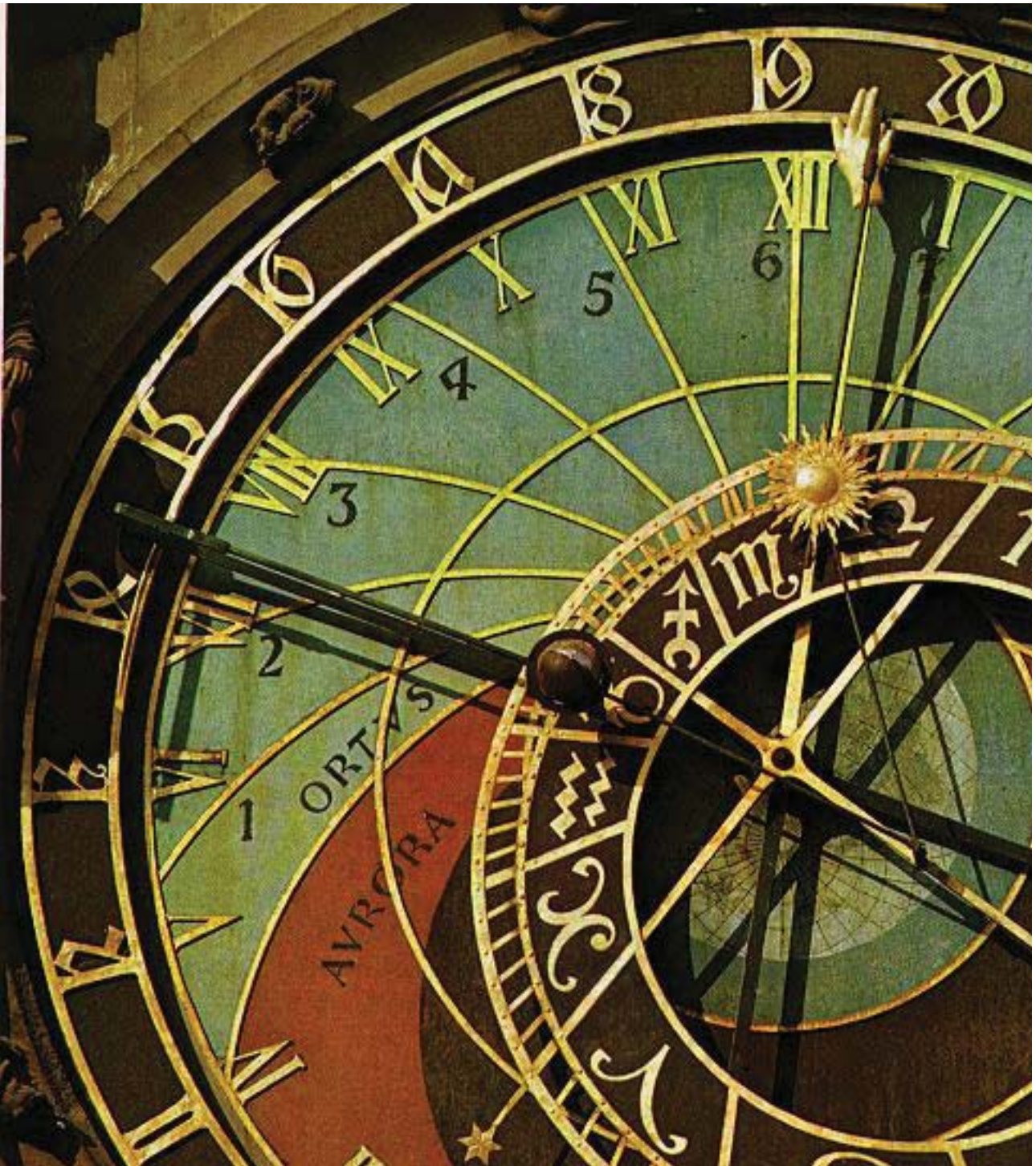

Question one

Read the passage below and answer the questions which follow:

It is hard to imagine a world in which there was no way to tell the time. And yet, compared with the history of humankind, time measurement as we know it is comparatively recent. However, observing and marking the passage of time in some way or other goes back to the dawn of the human race. How might early humans have viewed their world? It is entirely believable that they saw themselves as a part of their environment, rather than somehow superior to it as we have come to think of ourselves. It is not altogether odd that the apparent harm we are doing to our environment in so many ways has at last turned us back to seeing ourselves as part of, and custodian of, our planet. So in the days of which we are thinking, humans were at one with nature. We are surrounded by cycles of birth, growth and death. People and animals live and die. So do plants, some on a shorter time scale, some on a longer. Who can fail to marvel at the great oak growing from the acorn? Without the benefit of our lofty understanding, early people would have seen the sun born and dying each day; the Moon doing the same in a different way over a longer period; the earth herself repeating the seasons over and over and over again. All these cycles - animal, solar, lunar and seasonal - have different characteristics, but the common theme is birth, growth and death. Exercising their reasoning power, early people must have seen themselves as having an increasing control over themselves and their environment, a control which they might - wittingly or otherwise - think could be extended from the real (making fire, growing crops, harnessing animals) to the pretend (making rain, calling up eclipses, conciliating the spirits).



a) Circle the word or phrase which gives the best explanation of the underlined word or phrase as it is used in the passage. The first has been done for you.

Custodian	guardian	servant	master
Marvel at	see	admire	reflect on
Lofty	high up	advanced	terrific
Characteristics	features	characters	markers
Reasoning power	senses	exertion	rational thought
Wittingly	deliberately	sensibly	funnily
Conciliating	communicating with	pacifying	damaging

[6]

(b) What can you learn from this source about the different ways ancient and modern people viewed their environment? Use your own words to explain your answer.

[2]

(c) The passage describes how the common theme of all life cycles is “birth, growth and death”. Explain in your own words how this is shown in the cycle of the seasons. Answer the question fully.

[4]

Question two

As far as we know, it was about 5,000 to 6,000 years ago that the great civilisations in the Middle East and North Africa began to use instruments to show the passage of time each day, and also began to devise calendars to calculate and record more extensive periods of time. The Egyptians, as early as 3500BCE, divided their days into parts something like our hours, observing the shadows cast by obelisks (slender, tapering, four-sided monuments up to 30 metres high) and the ways in which these shadows moved across the ground as the sun moved across the sky. The ancient culture of Babylonians is credited by the Greek historian Herodotus (480-420 BCE) with producing the first sundial, and the earliest existing sundial we have today dates to about 1500 BCE. The Greeks developed the design and accuracy of sundials, and the Romans made popular the use of such devices. The first sundial set up in Rome in 260 BCE was captured by a victorious Roman general in Sicily and erected in a public square for all to see; it stood over an inscription in which the people of Rome recorded their military conquest and then claimed to have tamed time itself in the 490th year after the foundation of their city by Romulus. A century later another sundial was brought to Rome, again as a war trophy, to record the fact that the Roman army, a mere thirty years after occupying Greece, had now taken over the neighbouring kingdom of Macedonia, having practically annihilated the Macedonian army at the battle of Pydna. Later Roman generals followed the same pattern, but on a grander scale. Thus the emperor Augustus brought a great obelisk all the way from Egypt to Rome to serve as a monument to his defeat of the Egyptian queen Cleopatra in the sea battle at Actium in 30BCE, and seventy years later his great-grandson, the emperor Caligula, set up a yet greater obelisk in his newly-built stadium to honour his father, Germanicus, who had died twenty years before.

BCE is also written as BC; CE is also written as AD

a) Approximately how old was Herodotus when he died? _____ [1]

b) In what year did the Romans think Rome was founded? _____ [1]

c) What disadvantages do you think the Babylonians would have found with sundials as a means of telling the time? Try to think of at least two, and explain your answer.

d) Plot the following events on the timeline below. The first has been done for you:

- A First sundial in Rome
- B Death of Herodotus
- C Death of Germanicus
- D Opening of Caligula's stadium
- E Foundation of Rome
- F Battle of Actium
- G Roman occupation of Greece

[6]

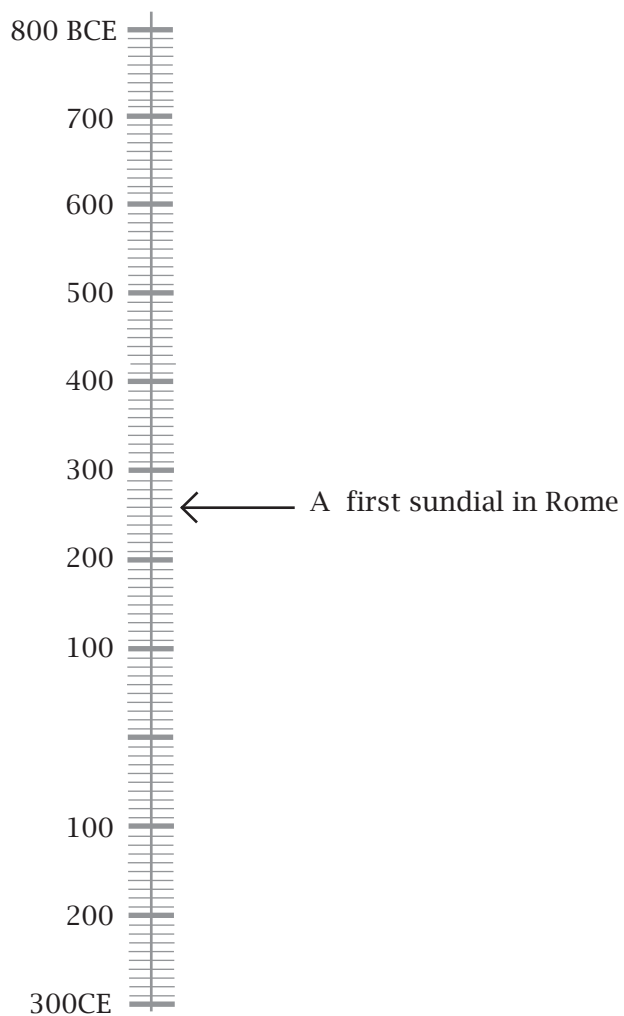

Obelisk in Karnak, Egypt,
set up around 1470 BCE

Question three

Alongside sundials, the Romans also used the originally Greek system of the water clock or clepsydra to observe the passage of time. These were among the earliest timekeepers that didn't depend on the observation of the sun and the moon and were simply bowls which allowed water to drip out at a constant rate through a small hole into containers. These devices were first used to mark a specific period of time – for example, to time speeches in law courts and prevent things going on too long. To convert this from a mere timer to something more like an actual clock at first involved catching the water that flowed out in another container which had markings on the inner surface, and measuring how far the water level reached.

More complex and impressive mechanised water clocks were developed between 100BCE and 500CE by Greek and Roman scientists. These were aimed at producing more elaborate and precise displays of the passage of time, using the rising and falling of water levels in various containers to move cogs and wheels in increasingly complicated machinery. As time went on, such water clocks could ring bells and gongs, open doors and windows to show little figures of people, or move pointers, dials and astrological models of the universe.

The Roman writer Vitruvius describes below how Ctesibius of Alexandria in the first century BCE developed a prototype of a waterclock which was altogether more useful as a public timepiece:

First he created a raised container (A) fed by a steady inflow of water(B) and with an overflow(C), and an aperture (D), made of gold or a perforated gem, because these are not worn down by the impact of the water, and not being susceptible to corrosion they will not become blocked. Now water flowing evenly from the first container(A) through this aperture(D) through a pipe into a second container(E), raises an inverted bowl, or float, called a psellos (F). A bar (G) is fixed to this float with teeth on its other end that engage with teeth on a revolving drum (H), and so create small rotations and movement in a pointer (I). When the water level in the second container (E) reaches a certain point, it drains away through an outflow (J) and so the whole process may be repeated as a constant cycle, and the time thus registered.

(a) Below is a diagram of Ctesibius' waterclock. Label the key elements of its mechanism (A to J) clearly, using the lines provided. The first (A) has been done for you.

[5]

Diagram of waterclock

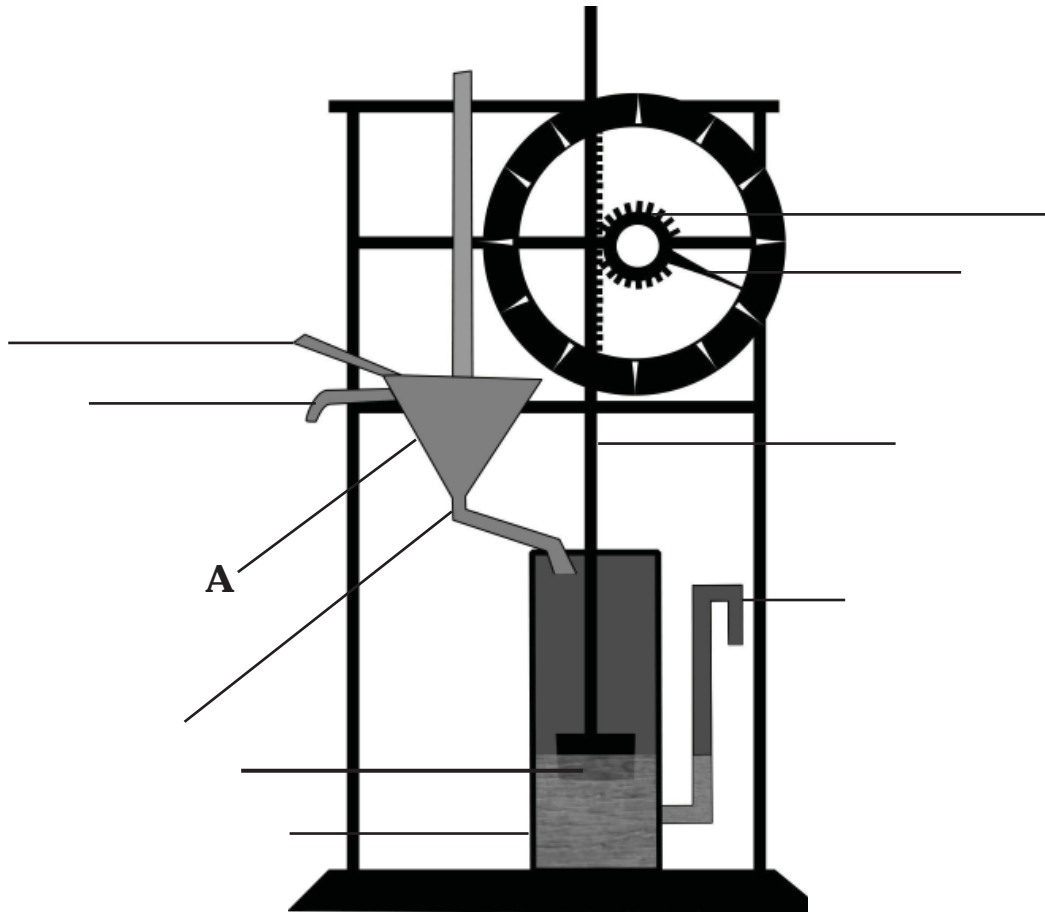

(b) In what ways do you think Ctesibius' waterclock was more 'useful as a public timepiece' than the more simple clepsydra described in the first paragraph?

Give at least two ways and explain your answer.

[5]

c) Read the information about the Romans in Questions 2 and 3 again.

What do you learn about the Romans from these passages?

Think of at least two ideas.

Give reasons for your answers.

[6]



Obelisk in Piazza del Popolo
erected by Roman general in a square in the centre of Rome

Question four

The type of mechanised water clock developed by Ctesibius was just one of the timekeeping devices made available to the citizens of Athens in the so-called Tower of the Winds, which was built in one of the main market places in Athens in around 50BCE. This is a 12 metre tall octagonal structure visible to this day, with a diameter of about 8 metres and topped in antiquity by a weathervane that indicated wind direction. On each of its eight sides was a sundial, and inside there was a water clock driven by water held in a reservoir on the slopes of the adjoining hill. Above the sundials was a frieze depicting the winds from the eight points of the compass. As you can see in the picture below and the more detailed pictures over the page, the winds were given a human form and showed in their clothing and what they carried the type of weather which they brought.

Tower of the Winds

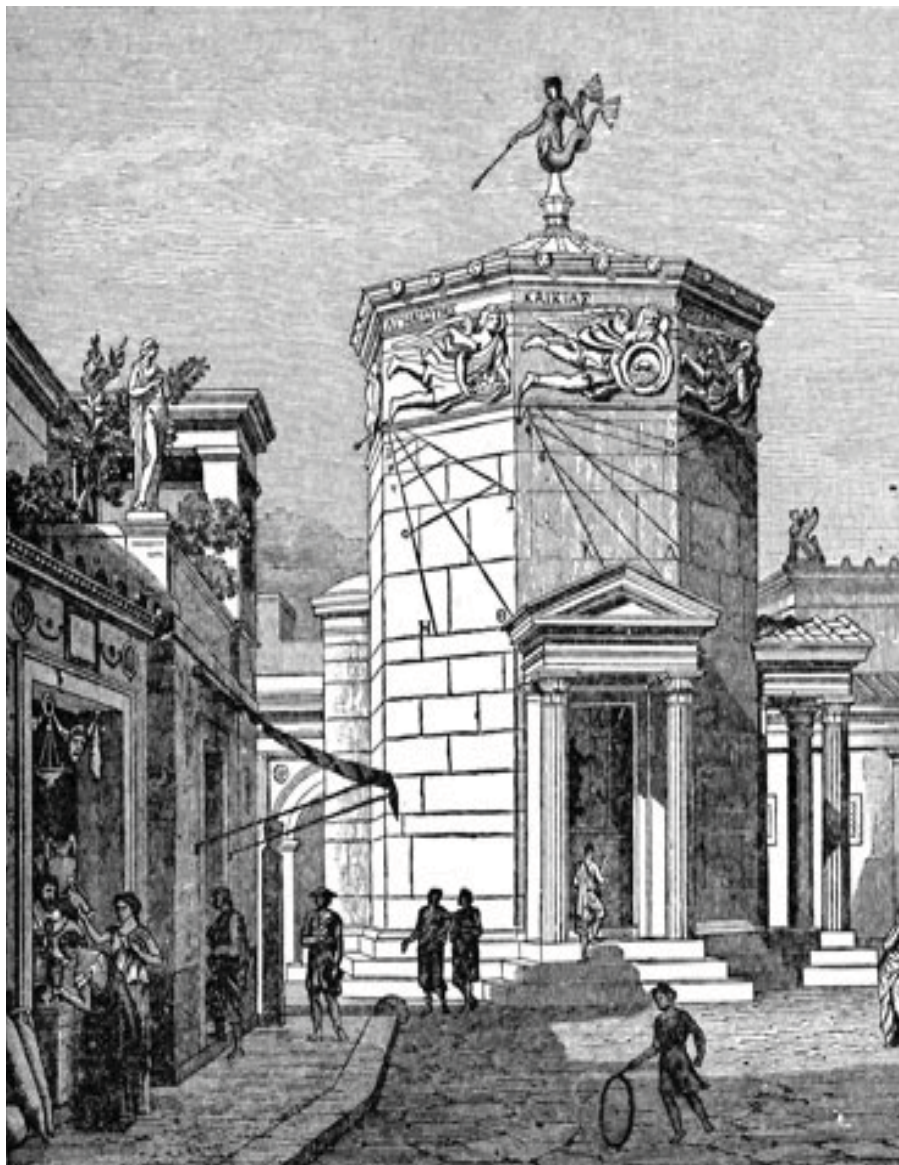



A



E



B



F



C



G



D



H

(a) In the table below, using the evidence from the pictures, identify the winds A to H. One has already been done for you.

Letter	Name of wind	Wind direction	Description of sculpted character
	Boreas	North	Old man wearing a heavy cloak, blowing through a twisted shell
	Kalkias	North East	Man carrying and emptying a shield of hailstones
	Apeliotes	East	Man holding a cloak full of fruit and grain
	Euros	South East	Old man tightly wrapped in a cloak against the elements
	Notos	South	Man emptying a container of water
D	Lips	South West	Boy pushing the stern of a ship
	Zephyros	West	Youth carrying flowers
	Skiron	North West	Bearded man with a bronze pot full of hot ashes

[7]

(b) Look at the details of the sculpted figures, and then sort the eight winds into the following categories. Use each wind only once.

i) List the four winds by name which were associated with cold weather:

_____ [4]

ii) Which wind was regarded as rain-bearing? _____ [1]

iii) Which wind blew in September? _____ [1]

iv) Which two winds blew in the Spring? _____ [2]

v) Describe how the sculptor has chosen to show the two Spring winds. Why do you think he has chosen these details? Explain your answer.

i)

ii)

_____ [4]

Question five

Below are two passages describing how a new method of marking time was developed. Read them both and then answer the questions which follow.

Passage 1

The discovery that led to the invention of a mechanical clock was made in the 16th Century by the Italian scientist Galileo Galilei. One day, when he was attending a service in the cathedral at Pisa, he watched the swinging of a big chandelier that hung from the ceiling. Then he noticed that each swing of the chandelier took the same amount of time. Sometimes it made big swings quickly; sometimes it made small swings slowly but it always took the same time to travel from one side to the other. Many years later, Galileo did some experiments to learn more about how a hanging weight or 'pendulum' swings. He found that the size and weight of the pendulum doesn't affect the time it takes to make its swing. The time depends only on the length of the string that the weight is hanging on.

Passage 2

Here's Galileo at a Sunday service in the cathedral. He's bored rotten and begins to day-dream. He looks up and sees that one of the lanterns is swinging backwards and forwards. As he watches, he realises something.

"It always takes the same time for the lantern to swing backwards and forwards".

Excited, Galileo runs home and experiments with weights on long pieces of string. He's right - the weight always takes the same time to swing. He has invented the pendulum! He thinks that this might be a good way to measure time. Unfortunately, Galileo doesn't get to use his pendulum to make a clock because he gets more interested in space - a big mistake for him.

a) In what ways are these two descriptions similar in their description of Galileo's findings? Explain your answer.

[4]

b) In what ways are the two accounts different?

[4]

c) Why do you think the second description is written in the style it is?

[3]

d) Which passage do you think is more useful for finding out about Galileo? Give reasons for your answer.

[3]

e) Find an example of a FACT and an OPINION in the second passage.

FACT

OPINION

[2]

Question six

A pendulum is any mass which swings back and forth on a rope, string or chain. You can repeat Galileo's pendulum experiments by releasing a mass or bob swinging on the end of a string. The size of the swing is changed by pulling the pendulum back and releasing it from different angles. The time it takes for each full swing back and forth is timed using a stop clock although Galileo used his pulse as a timing device!

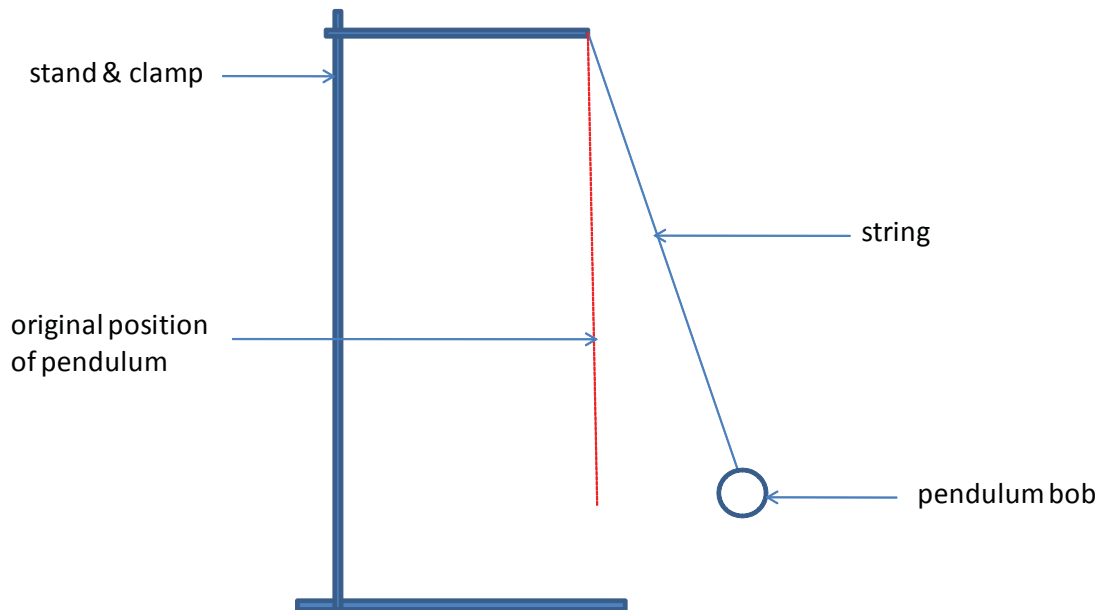

a) What is the aim of this experiment? Choose one of the following:

- i) to find out if the angle of the pendulum affects the number of complete swings
- ii) to find out if the time taken by each swing affects the angle of the pendulum
- iii) to find out if the angle of the pendulum affects the time taken to complete one swing

[1]

b) Describe how you would use the apparatus above to investigate Galileo's claims. You can use extra items that are not shown in the diagram too. Set out your instructions so that someone else could follow them to do the experiment.

[5]

c) Whilst carrying out the experiment you would need to keep some things the same (variables) in order to make it a fair test. Suggest two things that you would keep the same and describe how you would do this. Explain how they could affect your findings if they were not kept the same.

[4]

Some science teachers also decided to copy Galileo's experiment. Their results are below.

Angle (°)	Time taken for 10 swings (s)
5	7.0
15	6.9
30	7.0
45	7.0
60	7.5

[4]

d) On the graph paper draw a graph to display the results of the experiment.



e) Do the teachers have enough evidence to support Galileo's claim? Explain your answer.

[2]

Question seven

You are shipwrecked on a remote desert island. You have searched all the cargo containers which were washed up from the wreck but you cannot find a watch, clock or calendar of any kind. Your task is to devise a method to enable you to keep track of time until you are rescued.

The items you did find in the cargo are as follows:

Ball of string

Plastic sandwich bags

Chalk

Pen Knife

Ruler

Axe

1000 cm³ measuring cylinder

Plastic bucket

Permanent marker pen

2 polystyrene cubes (10 cm x10cm x10cm)

Mathematical compass

Saw

Mirror

Reel of strong wire

1m length of rubber tubing

Devise a timepiece which will tell the time as accurately as possible. You do not need to use all the items listed above. You can describe it and draw diagrams

