



"Doing the Lord's Work ....One Cup At A Time"

# Water Purifier Operating Manual



[www.airmobile.org](http://www.airmobile.org)

Rev. 2024

P.O. Box 406

Sneedville, TN 37869

Office 321-544-7757



# Table of Contents

## Contents

<b>Quick Start Guide</b> .....	<b>2</b>
<b>Limited Warranty</b> .....	<b>4</b>
<b>Water Purification Operational Notes</b> .....	<b>5</b>
<b>Cleaning Venturi Orifice</b> .....	<b>8</b>
<b>Emergency Parts Kit</b> .....	<b>11</b>
<b>Frequently Asked Questions–FAQ’s</b> .....	<b>13</b>
<b>Technical Data</b> .....	<b>17</b>
Operating Characteristics.....	<b>17</b>
System Specs.....	<b>18</b>
System Operating Claims.....	<b>18</b>
Contamination Production Claims.....	<b>18</b>
UV Lamp Bacterial Kill Table.....	<b>19</b>
UV Lamp Mold Kill Table.....	<b>19</b>
UV Lamp Protozoa Kill Table.....	<b>20</b>
UV Lamp Virus Kill Table.....	<b>20</b>
UV Lamp Yeast Kill Table.....	<b>20</b>
Ceramic Filter Filtration Data.....	<b>21</b>
<b>Cleaning Procedures</b> .....	<b>22</b>
<b>Contents of Unit</b> .....	<b>23</b>
<b>Exploded Diagram &amp; Parts Lists</b> .....	<b>25</b>



# QUICK START GUIDE

**Step 1- Remove the water purifier from the carrying case and inspect for transportation damage. DO NOT USE the unit if any of the plastic filtration housings are cracked or electrical wires have been disconnected.**

**Step 2- Remove the red intake port cap at location (2) and attach clear plastic intake hose (3) to the intake port (2) on the front of the unit.**

**Step 3- Connect wall outlet power cord to the side connector port at location (4) OR portable power supply at front location Red to Red (positive pole +) and Black to Black (negative pole -) (5)**

**Step 4- Attach the waterspout (9) to the top of the UV module by pressing the chrome end into the center hole on the top of the module at the location (6).**

**Step 5- submerge the suction end of the clear plastic hose (7) into a water supply.**

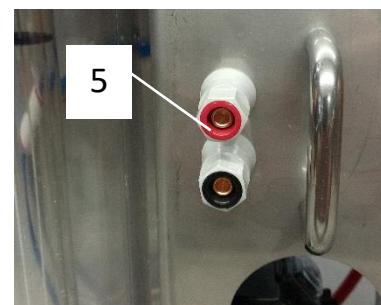
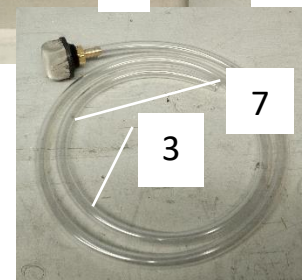
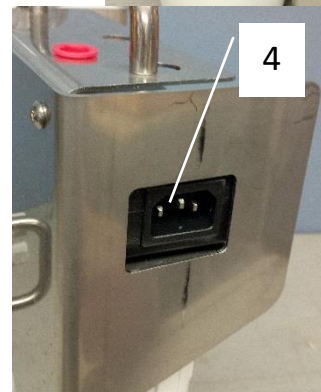
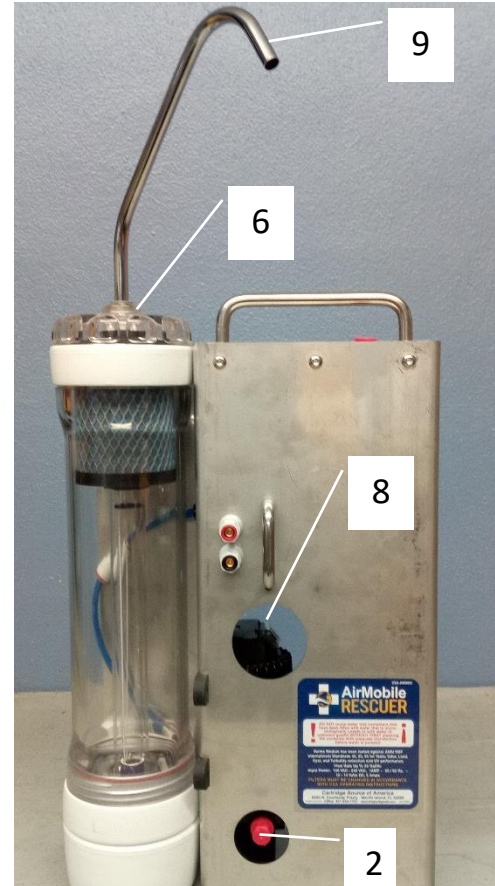

# QUICK START GUIDE

**Step 6-** position the outlet end of the spout as not to drop water on the unit. Place a bucket under the spout to collect the clean water.

**Step 7-** Place the white feet (12) on three locations on the unit. One on the front near the intake valve, one on the right side, and one on the back of the unit under the ceramic filter housing.

**Step 8-** Turn on the water purifier by pressing the on/off toggle switch at location (8).

**Step 9-** After the unit starts to pump and the UV light Turns on, clean water will start to emit from the spout (9). Let water flow for one minute before collecting for drinking. The water purifier combines several proven technologies that work together to eliminate the threat of waterborne disease.

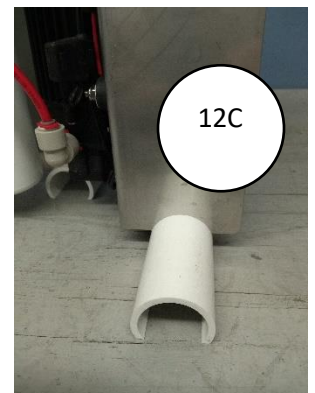
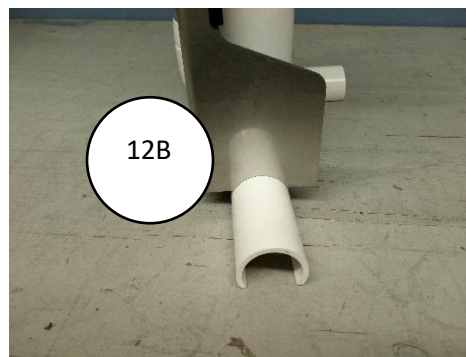
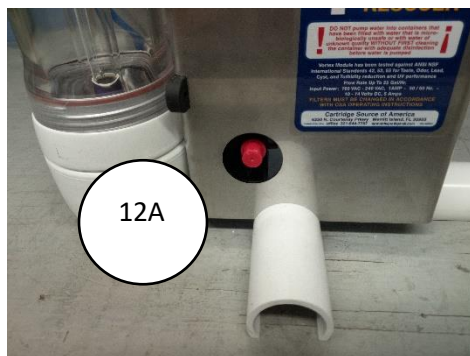

# LIMITED WARRANTY



www.airmobile.org



**P.O. Box 406 Sneedville, TN 37869**

**LIMITED WARRANTY CLAUSE** For a period of one year from the date of original purchase, CSA will replace or repair any part of the water purification and filtrations systems that we find to be defective in operation due to faulty materials or workmanship with the exception of the replaceable ceramic and activated carbon filters. This warranty clause does not apply to those systems that have been donated to humanitarian relief operations.

**WARRANTY TERMS AND CONDITIONS** Damage to any part of this system because of misuse; misapplication; negligence; alteration; accident; installation; or operation contrary to the operating instructions, or damage caused by freezing, rain, flood, or fire, is not covered by this warranty. In all such cases, regular repair charges will apply. This limited warranty does not include survice to diagnose a claimed malfunction in this unit. This warranty is void if the claimer is not the original purchaser of the unit or if the unit is not operated under normal municipal water or well water conditions.

We assume no warranty liability in connection with this System other than that specified herein. This warranty is in lieu of all other warranties, expressed or implied, including warranties of fitness for a particular purpose. We do not authorized any person or representative to assume for us any other obligations on the sale of this system. This warranty purification and filtration system has been both independently tested and tested a CSA prior to sale. Before returning any water purification and filtration for warranty repair, the original purchaser must contact CSA and request a "Return Authorization Number (RMA)". Contact CAS by Calling [airmobilejoe@gmail.com](mailto:airmobilejoe@gmail.com).



# WATER PURIFIER OPERATIONAL NOTES



## Installing Base Stabilizers

For additional stability, install the white PVC Base Stabilizers by placing the metal case over the slotted area, as indicated in this figure and press down with the metal casing unit fully seated.

**CAUTION:** Avoid unnecessary force on the plastic “Water circulation / Ultraviolet Light” assembly during this step.



## Electrical Power Connection Options

The water purifier can operate on 12volts DC power or ac power from 90-250 volts, 50 or 60 cycle. The electrical kit components include wiring for 12 VDC connection or ac power cord and adapters to suit various international applications. Spare electrical fuses are also included in the delivery.



## Overall Operational View

Water purifier operational set-up is shown on left. This example demonstrates use of a 12 VDC car battery as the source of the electrical power. Note: This configuration as shown, using the battery connector parts provided in this delivery, has two electrical power switches “in-line” and both switches must be “ON” to operate the filter. The main switch is on the Rescuer unit, but the additional switch, in the battery wire-harness itself, may be difficult to locate.

# WATER PURIFIER OPERATIONAL NOTES

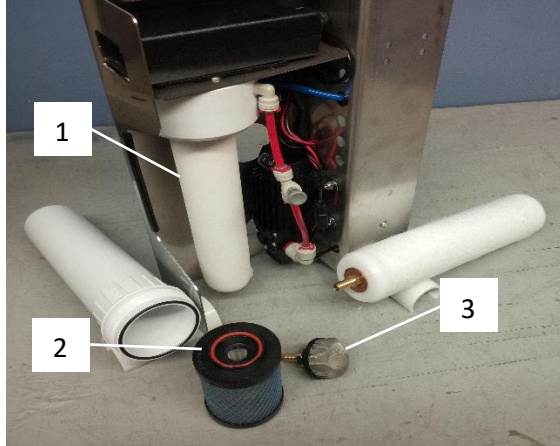

## Included System Water Filters

- (1) 0.9 Micron Absolute Ceramic Filter
- (2) Activated Carbon Filter Large
- (3) Coarse Particle Pre-Filtration

Note: See “Frequently Asked Questions FAQ’s” provided in this Documentation for filter details/specification.

## Access to the Ceramic Filter

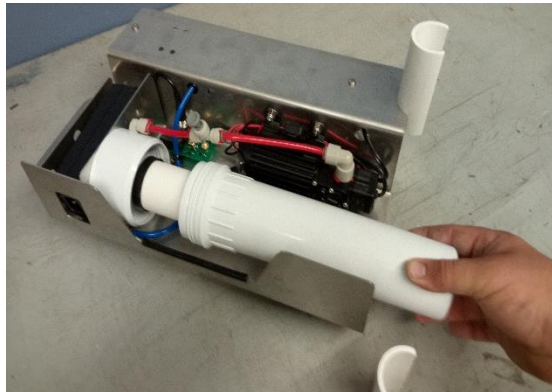

When it is necessary to clean the ceramic filter due to low water flow, while the unit is upright, remove the white outer case and drain any residual water. Then lay the unit down and remove the threaded ceramic filter. When reinstalling the filter and case after cleaning, as shown in the picture, DO NOT over-tighten, use only enough force to seat the “O” Rings. Use Latex gloves as necessary for personal Protection for Biological Hazards.

## Ceramic Filter “Cleaning”



**Be Gentle** when handling the ceramic filter. When cleaning the ceramic filter, use the latex gloves provided as Personal protection for biological hazards. Use the cleaning pad provided by Air Mobile Rescuer and rinse/ wipe away any filtered residue until the ceramic surface is exposed. Be gentle when cleaning the exposed ceramic material, as a portion of the actual ceramic surface will erode in the cleaning process. For this reason, after extensive operation with the internal filter, the replacement filter, provided in the delivery, can be installed.



# WATER PURIFIER OPERATIONAL NOTES



**WARNING!!!** Removing Ultraviolet Light chamber cap with electrical power ON will expose Ultraviolet Light source. To protect against eye damage, **always unplug** electrical power before servicing.

**\*\*\*SEE OWNERS MANUAL\*\*\***

## **Access to Carbon Filter**



To remove and replace the carbon filter, disconnect all electrical power to avoid direct UV light exposure. Gently rotate the filter (as if it were threaded) as you pull gently upward. This is best done if the system has been wetted and the lower red-colored "O" Ring seal that touches the glass tube is moist. Replace the cartridge with a slight rotation while pushing downward until fully seated.

## **To Clear "Vapor Lock"**



When the intake hose is removed from the water during operation and the water pump intakes air, a "Vapor Lock" may occur in the pump and water will not flow. To clear a "Vapor Lock" (1) place the intake hose underwater and, (2) locate the pressure release fitting, depress the upper ring of this fitting with your thumb-nail as shown in picture at left, thereby releasing air pressure.

# CLEANING VENTURI ORIFICE



First, empty water from the unit by removing top cap and tipping. Placing fingers in front so that the water washes by will allow the sealing O-ring to be caught without being washed away.



Pour 1 Inch of CLR or white vinegar into the uv chamber.



Using Needle nose pliers remove red lock ring from the top of the fitting on the side of the unit. (blue tube)

# CLEANING VENTURI ORIFICE



Using the John Guest wrench press down on the top of fitting and pull out the blue tube.



From the tool kit retrieve the syringe and the small blue tube. Press the blue tube on to the end of the syringe. Then fill the syringe with CLR or Vinger.



Insert the blue tube in to the fitting on the side of the unit thus connecting the syringe to the unit and squeeze the liquid through the blue tube and into the bottom of the UV chamber. Retract the syringe plunger effectively pumping the liquid back and forth through the venturi and cleaning it. Continue to pump the liquid for about a minute or until the liquid flows freely.

# CLEANING VENTURI ORIFICE



Retract the syringe plunger completely and using the John Guest wrench. Press the locking ring with the wrench and pull the blue syringe tube out of the fitting. Dispose of the used liquid in the syringe.



Tipping the unit inverted and pour out the cleaning liquid.



Reinstall the blue tube by pressing the tube securely into the fitting.



Reinstall Red retainer ring in to the fitting. Run the unit for a minimum of 10 minutes to flush out any residual cleaning liquid. **DO NOT** consume the water that is purified during the 10 minutes of flushing.

# EMERGENCY PARTS KIT



**John Guest Fitting Wrench**  
(Used to push down lock ring of fitting to remove tubing for plug)



**Small O-Ring**  
(For carbon filter)

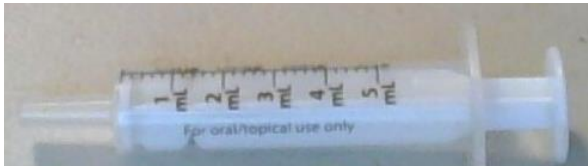

**Venturi Orifice Cleaner**  
(With hose used to inject cleaner of calcium buildup)



**Large "Slimmer" O-Ring**  
(For ceramic filter housing)



**Connector and  
Emergency Spout**  
(Used to extend length of clear tubes)



**Large "Fatter" O-Ring**  
(For reactor top)

# EMERGENCY PARTS KIT

## Replacement Fuses



### 10 Amp Fuse

(For Cigarette Lighter Plug)



### 2 Amp Fuse

(For ballast board located under  
Bottom cap of Reactor Module)

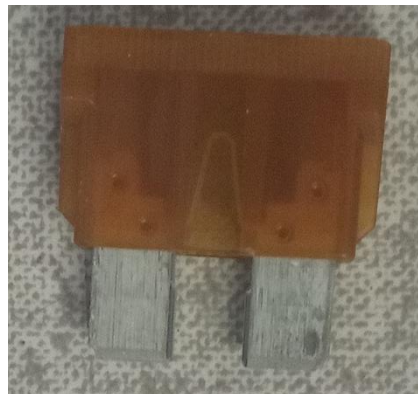

### 5 Amp Fuse

(For Water Pump)

# Frequently Asked Questions–FAQ's



P.O. Box 406  
Sneedville, TN 37869  
321-544-7757

## **How long can the water purifier run?**

A good duty cycle is eight hours.

## **What does the water purifier do?**

The water purifier is a seven stage, self-contained electromechanical water filtration and purification system that can provide fresh drinking water. The system has been designed to remove sediment, and destroy bacteria and viruses from untreated water sources such as rivers, streams, lakes, ponds, springs, reservoirs and wells.

## **What are the seven stages and what do they do to purify the water?**

Stage 1 – Large particle pre-filtration.

Stage 2 – Sub micron particle pre-filtration and water clarification.

Stage 3 – Ozonation.

Stage 4 – Ultraviolet (UV) light exposure.

Stage 5 – Photo–Oxidation.

Stage 6 – Activated Carbon Post Filtration.

Stage 7 – Post filtration UV.

For more detailed information on the processes above please see Technical Data Sheet

## **What is photo-oxidation?**

Photo oxidation is a process generated in nature by lightning. We simulate it within the unit. The process, when coupled with the UV light, creates a powerful cleaning process that is unsurpassed by any other water purification unit..

## **What does the UV light do and is it harmful to humans?**

UV light is the same light that comes from the sun. When the UV light couples with the ozone it creates photo oxidation. This process can be up to 30,000 times more powerful than chlorine. The water in the UV chamber is exposed to this natural cleaning agent twice during the purification process. And unscreened UV light can be very dangerous. The UV exposure intensity is in excess of 22,500  $\mu\text{W}$  seconds per square centimeter. Within the system it is safe due to the protective clear housing that surrounds it. If that glass ever breaks, the light can be harmful to the eyes.

## **How much water does the purifier produce?**

The unit is rated for up to 25 gallons per hour. The water flow will generally depend upon the amount of debris in the water as well as the cleanliness of the ceramic and carbon filters.



# TECHNICAL DATA SHEET

(SYSTEM SPECIFICATION, OPERATING CHARACTERISTICS,  
AND CLAIMS)

## **How much power does the unit draw?**

The unit uses approximately 55 Watts per and can be operated by 12 Volts DC power or by 100 – 250 Volts AC power.

## **How does the output spout release?**

The unit uses a John Guest fitting. These must be depressed at the base in order to remove the spout. The same fitting is attached in the bleeding vapor lock line.

## **The machine is not pulling water/there is no suction. How do I fix this?**

The most common reason is due to a vapor lock that is caused by air getting into the suction tube. To break the vapor lock: turn the unit off, depressed the John Guest fitting in the red tube in the back and remove the pin. This will break the seal and you will hear the air bubble being released. Replaced the pin in back in the fitting and continue pumping. If this does not solve the problem please contact us at [airmobilejoe@gmail.com](mailto:airmobilejoe@gmail.com)

## **There is water coming out of the top or bottom of the unit. How do I fix this?**

This is commonly caused by a missing blue/orange O ring in the top. Unscrew the unit and inspect for a blue/orange O ring that Seals the cap. If it is missing, use one of the replacement loop/orange O rings provided in your case.

## **The unit seems to be functioning properly but the water has changed flavor. Why has this happened?**

It could be that the carbon filter needs to be changed. It could also be that the small quartz size O ring, from above or below the carbon filter that is resting on the UV light, is missing or is not sitting tightly. Either fix the position of the O-ring or use the small orange replacement O-ring provided in your carrying case.

## **The unit is pulling water and I can see that ozone bubbles but there is no UV light. How do I fix this?**

**DO NOT DRINK THE WATER!!** Even though it has been run through the 1 µm ceramic filter, it has not been purified by the UV light. It is possible that the fuse for the UV light is blown. Carefully flip the unit over and unscrew the two screws at the bottom part of the unit that contains the UV light there is a replacement fuse in the bag of extra parts. Remove the old fuse and place the new one in its place. If this does not fix the problem please contact us at [airmobilejoe@gmail.com](mailto:airmobilejoe@gmail.com).



# TECHNICAL DATA SHEET

(SYSTEM SPECIFICATION, OPERATING CHARACTERISTICS,  
AND CLAIMS)

**The unit is pulling water but the UV light has shut down and the ozone bubbles are not present. What happened?**

**DO NOT DRINK THE WATER!!** Even though it has been run through the 1 µm ceramic filter, it has not been purified by the UV light or ozone. The most common reason for the lack of UV and ozone is that your filters are clogged. The filter life generally depends upon the amount of debris in the water. The ceramic filter is rated for approximately 10,000 gallons and needs to be cleaned approximately every 100 gallons. You will know when it is time to clean the ceramic filter when the water source slows down or when the ozone and/or light turnoff.

**How do I clean the ceramic filter?**

The ceramic filter is located in the back of the unit inside of its white protective cover. If you are not sure which one contains the ceramic filter, please see the instruction manual. Remove the white ceramic filter housing and, with protective gloves preferably, unscrew the filter. It should not be screwed in very tightly. Use a scrubber, like the one provided with the unit, to softly and evenly wipe the outer layer of the filter. You should see a color change, more of a white color as the next layer is revealed. Carefully replace the ceramic filter back in its place. Again, it does not need to be overly tight. We provide one new ceramic filter with each unit. If you need another filter please contact us at [airmobilejoe@gmail.com](mailto:airmobilejoe@gmail.com).

**What does the carbon filter do and how long does it last?**

The carbon filter is there for taste and for removing heavy metals. It should be changed approximately every year.

**Does the water still have the necessary minerals in it that my body requires?**

Yes. Through the process of purification all the harmful contaminants are removed but all of the quality minerals that naturally come in water remain. This is essential for good health.

**How long can the unit be stored?**

The unit can be stored drive for up to 10 years. When the unit has water in it, it is best to completely remove all water from the UV housing as well as the ceramic filter housing and let it dry out. Leave the ceramic filter and carbon filter out of the unit and store it in a safe area as they are delicate and can be damaged.

**What is the life expectancy of the UV lamp?**

The lamp life is 10,000+ on/off cycles – approximately two years of normal use.





# TECHNICAL DATA SHEET

(SYSTEM SPECIFICATION, OPERATING CHARACTERISTICS,  
AND CLAIMS)

## **When do the components need to be serviced or replaced?**

- Suction screen: no replacement needed
- Suction Filter Replaced after 1000 gallons. Actual replacement depends on the quality of water being filtered.
- 0.9 Micron Absolute Ceramic Prefilter: Filter can be cleaned multiple times before replacement.
- Purification Post Filtration Module (PFM) Lamp: lamp life 10,000 on/off cycles.
- Purification Post Filtration Activated Carbon Filter: filter style formed radio – flow activated carbon w/Engelhard ATS™ for lead removal – filter life 10,000 gallons or water starts to taste bad or smell.

# TECHNICAL DATA SHEET

(SYSTEM SPECIFICATION, OPERATING CHARACTERISTICS,  
AND CLAIMS)

**P.O. Box 406**

**Sneedville, TN 37869**

**321-544-7757**

The water purifier is a seven stage, self-contained electromechanical water filtration and purification system that can provide fresh drinking water. The system has been designed to remove sediment, and destroy bacteria and viruses from untreated water sources such as rivers, streams, lakes, ponds, springs, reservoirs and wells.

## OPERATING CHARACTERISTICS

- **Stage 1 – Large particle pre-filtration.** A stainless steel suction screen wrapped inside of a spun wound filter is used at the point of entry to remove any large particles.
- **Stage 2 – Sub Micron Particle Pre-Filtration and Water Clarification.** A 1 micron ceramic prefilter that has been impregnated with silver is used to remove sediment and improve clarity prior to the water purification process.
- **Stage 3 – Ozonation.** Ozone is generated within the unit and is mixed with the water that has passed stage 2. Like Lorene, ozone is a powerful oxidizer. Unlike Lorene, ozone leaves no chemical residue. Ozonation improves water taste by destroying contaminants.
- **Stage 4 – Ultraviolet (UV) Light Exposure.** That ozone saturated water is flooded with ultraviolet light.
- **Stage 5 – Photo–Oxidation.** A Ozone/UV Photo–Oxidation process takes place. Photo – oxidation is what makes the purification process unique, combining the ozone and UV light. Like a catalytic converter in your car the UV “catalysts” the ozone to process a rapid and effective reaction in a compact space.
- **Stage 6 – Activated Carbon Post Filtration.** Water is filtered through an activated carbon filter. The purification process uses a high-performance, 2 micron cartridge with a special lead-absorbent media. This filter is designed to trap dissolved lead and chlorine, and very small particles.
- **Stage 7 – Post Filtration UV.** As further protection against micro-organisms, the filtered water is again exposed to high density UV light.





# TECHNICAL DATA SHEET

(SYSTEM SPECIFICATION, OPERATING CHARACTERISTICS,  
AND CLAIMS)

**P.O. Box 406**  
**Sneedville, TN 37869**  
**321-544-7757**

## **System Specifications**

- DC model physical dimensions: 6.5" x 18.5" x 14"
- DC model dry weight: 27 pounds, including transportation case
- Power requirements: 12-18 V DC, 60 Watts maximum
- Power source-12v DC power supply or 120-240v AC 56-60hz
- UV exposure intensity: in excess of 22,500 microWatt seconds per square centimeter.
- Flow rate: up to ½ gallons per minute continuous
- Purification Post filtration model has been tested against ANSI/NSF standards 42, 53, and 55 for lead, cyst, chlorine and turbidity reduction, and for microbial reduction.

## **System operating claims**

- Suction screen: no replacement needed
- Suction Filter Replaced after 1000 gallons. Actual replacement depends on the quality of water being filtered.
- 0.9 Micron Absolute Ceramic Prefilter: Filter can be cleaned multiple times before replacement.
- Purification Post Filtration Module (PFM) Lamp: lamp life 10,000 on/off cycles.
- Purification Post Filtration Activated Carbon Filter: filter style formed radio – flow activated carbon w/Engelhard ATS™ for lead removal – filter life 10,000 gallons or water starts to taste bad or smell.

## **Contamination production claims**

- lead – greater than 99%
- cysts – greater than 99.95%
- turbidity – greater than 99%
- microbial, bacteria/viruses, reduction
- E-Coli-99.999%

## **Warranty**

- Material and Workmanship – one (1) year – See warranty certificate for full explanation

# TECHNICAL DATA SHEET

(SYSTEM SPECIFICATION, OPERATING CHARACTERISTICS,  
AND CLAIMS)

**Sneedville, TN 37869**

**321-544-7757**

The following is a UV industrial standard table showing the kill factor of the UV germicidal lamp contained in the airmobile rescuer emits a 22,500 energy dose. According to this table the lamp kills 100% 53 known bacteria, viruses, protozoa, yeast, and molds.

Organisms	Energy dosage of ultraviolet radiation in $\mu\text{W}/\text{cm}$ need to kill factor	
	90%	100%
<b>Bacteria</b>		
Bacillus anthracis-Anthrax	4520	8700
Bacillus anthracis spores-Anthrax spors	24,320	46,200
Bacillus magaterium sp. (spors)	2730	5200
Bacillus magaterium sp. (veg.)	1300	2500
Bacillus paratyphusus	3200	6100
Bacillus subtilis spores	11,600	22,000
Bacillus subtilis	5800	11,000
Clostridium Tetani	13,000	22,000
Corynebacterium Diphtheriae	3370	6510
Ebertelia typhosa	2140	4100
Escherichia coli	3000	6600
Legionella bozemanil	3500	7000
Legionella dumoffii	5500	11,000
Legionella gormanii	4900	9800
Legionella micdadei	3100	3100
Legionella longbeachee	2900	5800
Legionella pneumophila	3800	7600
Leptospiraicanicola-Infectious Jaundice	3150	6000
Micrococcus candidus	6050	12,300
Micrococcus sphaeroides	1000	15,400
Mycobacterium tuberculosis	6200	10,000
Neisseria catarrhalis	4400	8500
Phytomonas tumefaciens	4400	8000
Proteus vulgaris	3000	6600
Pseudomonas aeruginosa	5500	10,500
Pseudomonas Fluorescens	3500	6600
Salmonella enteritidis	4000	7600
Salmonella paratyphi – Enteric Fever	3200	6100
Salmonella typhosa- Typhoid Fever	2150	4100
Salmonella typhimurium	8000	15,200
Sarcina Lutea	19,700	26,400
Serratia Marcesens	2420	6160
Shigella Dyseteriae-Dysentery	2200	4200
Shigella flexneri- Dysentery	1700	3400

# TECHNICAL DATA SHEET

(SYSTEM SPECIFICATION, OPERATING CHARACTERISTICS,  
AND CLAIMS)

Shigella paradysenteriae	1680	3400
Spirillum rubrum	4400	6160
Staphylococcus Albus	1840	5720
Staphylococcus Aerius	2600	6600
Staphylococcus Hemolyticus	2160	5500
Staphylococcus Lactis	6150	8800
Staphylococcus Viridans	2000	3800
Vibrio Comma - Cholera	3375	6500
<b>Molds</b>	<b>90%</b>	<b>100%</b>
Aspergillius Flavus	60,000	99,000
Aspergillius Glaucus	44,000	88,000
Aspergillius niger	132,000	330,000
Mucor racemosus A	17,000	35,200
Mucor racemosus B	17,000	35,200
Oospora lactis	5000	11,000
Penicillium Expansum	13,000	22,000
Penicillium Roqueforti	13,000	26,400
Penicillium Digitatum	44,000	88,000
Rhisopus Nigricans	111,000	220,000
<b>Protozoa</b>	<b>90%</b>	<b>100%</b>
Chlorella Vulgaris	13,000	22,000
Nematode Eggs	4,000	92,000
Paramecium	11,000	20,000
<b>Virus</b>	<b>90%</b>	<b>100%</b>
Bacteriophage-E.Coli	2600	6600
Infectious Hepatitis	5800	8000
Influenza	3400	6600
Polivirus – Poliomyelitis	3150	6600
Tobacco Mosaic	240000	440000
<b>Yeast</b>	<b>90%</b>	<b>100%</b>
Brewers Yeast	3300	6600
Common Yeast Cake	6000	13200
Saccharomyces Carevisiae	6000	13200
Saccharomyces Ellipsoideus	6000	13200
Saccharomyces spores	8000	17600



# TECHNICAL DATA SHEET

(SYSTEM SPECIFICATION, OPERATING CHARACTERISTICS,  
AND CLAIMS)

## Ceramic Filter Specifications

American, British and Hong Kong laboratories have tested the Dalton Sterasyl Cartridge (Stage 2 Function) with the following results.

- NSF 42 – exceeds 85% particle 0.05 through 1.0 Micron reduction
- NSF 53- meets 99.5% cysts and 1.0 NTU turbidity reduction
- Bacteria Reduction – 99.99%
- Removed 100% Shigella Dypenteriae, Salmonella Typhi, and Vibrio Cholerae
- Heavy Metals Reduction 99.5% – 99.9%

Visit the Doulton Water Filter website at [www.DoultonUSA.com](http://www.DoultonUSA.com) for additional technical information and claims.



# Attention:

## Cleaning Procedures for the your Water Purifier

- **Important: always use personal protective equipment when following these procedures. (Examples of equipment are as follows but are not limited to: waterproof gloves, mask/face shield, protective eyewear, etc.)**
- Remove the housing that the ceramic filter is encased in (being careful not to lose the O-ring) and remove the ceramic filter. Clean ceramic filter with certain scoring pad that was furnished with your machine. Rinse the ceramic filter and a certain scoring pad with clean water. Let air dry.
- Drain the UV unit by removing the black, under the spout. Poor excess water out. (Be careful not to lose the O-ring) leave the cap off and let unit air dry.
- Remove the intake hose and pick up the filter/screen from the water purifier and rents in clean water and let air dry.
- White exterior housing with a soft rag dampened and let air dry. (Do not get electronic components wet)
- after all components are dry you can reinstall all parts, put scoring pad in plastic bag in place in case for storage.
- For technical assistance please call 321-544-7757. 8 AM- 5 PM Monday through Friday Eastern standard Time.  
Email support: [airmobilejoe@gmail.com](mailto:airmobilejoe@gmail.com)



# Contents of Units

<b>CONTENTS OF CASE</b>			
<b>Part #</b>		<b>Part discription</b>	<b># of Parts</b>
AMMR-	984	BLACK CASE PLUCKED AND GLUED	1
<b>or</b>			
AMMR-	985	YELLOW CASE PLUCKED AND GLUED	1
AMMR-	999	AIR MOBILE RESCUER TESTED	1
AMMR-	986	BLACK TOOL KIT	1
<b>or</b>			
AMMR-	987	YELLOW TOOL KIT	1
AMMR-	902	AIR MOBILE MINISTRIES RESCUER MANUAL	1
AMMR-	904	INTERNATIONAL TRAVEL PLUG ADAPTER KIT	1
AMMR-	905	STABILIZING FEET	3
AMMR-	600C	CERAMIC FILTER (ONE INSTALLED IN UNIT)	3
AMMR-	605	MUSHROOM FILTER	1
AMMR-	515	AC POWER CORD	1
AMMR-	520	FEMALE 12V ACCESSORY PLUG	1
AMMR-	521	MALE 12V ACCESSORY PLUG ASSEMBLY	1
AMMR-	330	CLEAR TUBING 5 FT	1
AMMR-	327	SILVER IMPREGNATED TUBING (SLIGHT TINT) 5FT	1
AMMR-	324	CHROME PLATED SPOUT PROCESSED	1
AMMR-	810	GLOVE AND CLEANING PAD	1

<b>CONTENTS OF TOOL KIT</b>			
<b>Part #</b>		<b>Part discription</b>	<b># of Parts</b>
AMMR-	901B	BLACK TOOL KIT BOX	1
<b>or</b>			
AMMR-	901Y	YELLOW TOOL KIT BOX	1
AMMR-	801	6" WRENCH	1
AMMR-	802	PLIERS	1
AMMR-	803	SCREWDRIVER SET	1
AMMR-	804	JG TOOL	1
AMMR-	805	CRINGE	1
AMMR-	811	USB BAG	1
AMMR-	525	FUSE BAG	1
AMMR-	499	O-RING BAG SUB	1

# Contents of Units

<b>CONTENTS OF FUSE BAG</b>			
<b>Part #</b>		<b>Part discription</b>	<b># of Parts</b>
AMMR-	511	FUSE 2.5 AMP	2
AMMR-	512	FUSE 5 AMP (CAR STILE)	1
AMMR-	513	FUSE 10 AMP	1

<b>CONTENTS OF O-RING BAG</b>			
<b>Part #</b>		<b>Part discription</b>	<b># of Parts</b>
AMMR-	400	O-RING REACTOR MAIN SEAL	1
AMMR-	404	O-RING CERAMIC FILTER HOUSING	2
AMMR-	406	O-RING SMALL CARBON FILTER SEAL	1
AMMR-	319	GRAY CONNECTOR TUBING	1

# Exploded Diagrams

## AIR MOBILE RESCURE CHASSIS ASSEMBLY AND PARTS LIST

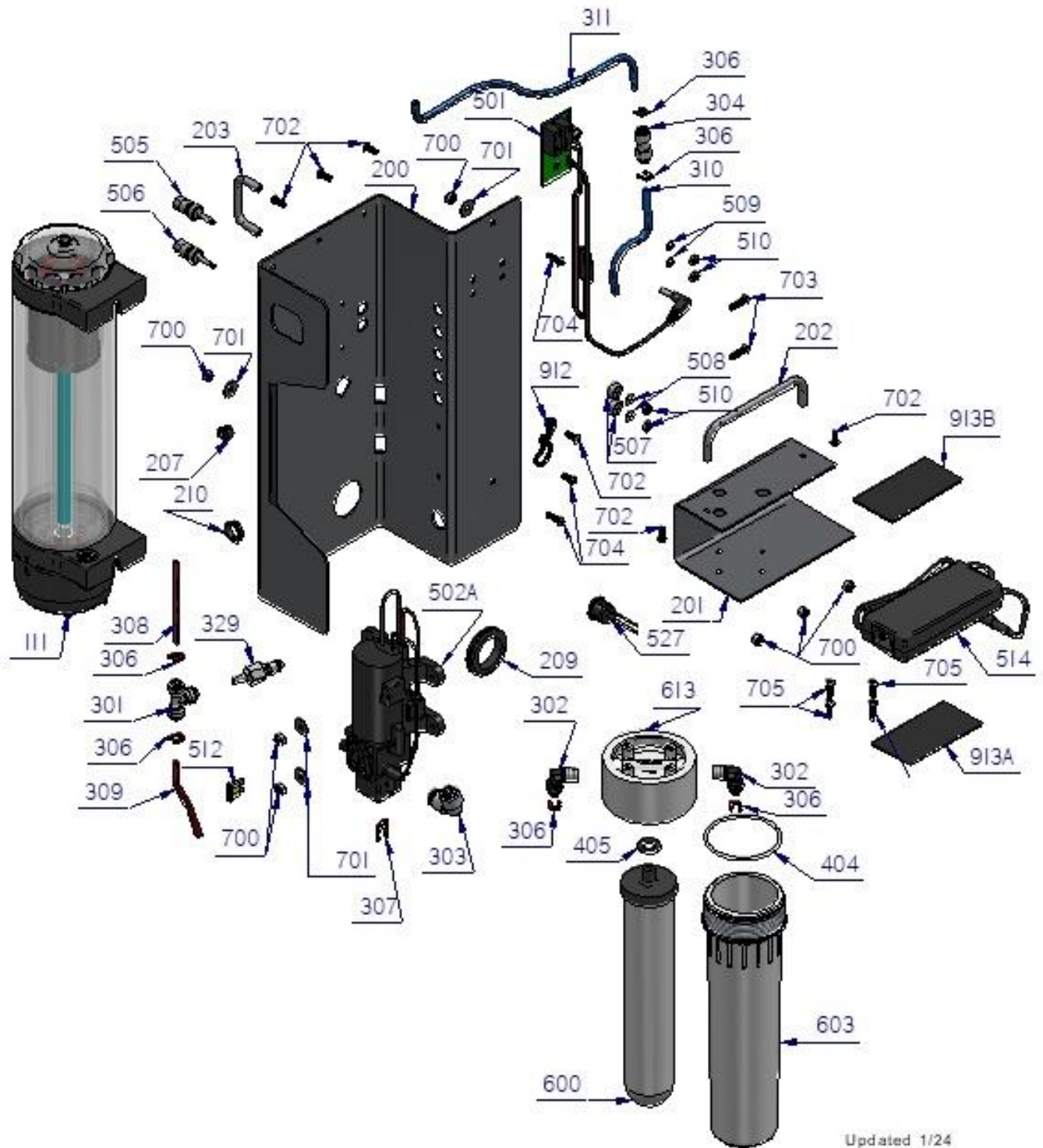

# Exploded Diagrams

AMMR-111	REACTOR ASSEMBLY	AMMR-507	BINDING POST SPACER
AMMR-200	CHASSE MAIN	AMMR-508	BINDING POST FLAT WASHER
AMMR-201	CHASSE POWER SHELF	AMMR-509	BINDING POST LOCK WASHER
AMMR-202	BIG HANDLE	AMMR-510	BINDING POST NUT
AMMR-203	SMALL HANDLE	AMMR-512	5 AMP FUSE
AMMR-207	TUBING PROTECTOR	AMMR-514	POWER SUPPLY
AMMR-209	FINGER PROTECTOR INLET TUBE	AMMR-527	POWER SWITCH
AMMR-210	POWER PROTECTOR	AMMR-600	CERAMIC FILTER
AMMR-301	.25 T-FITTING	AMMR-603	CERAMIC FILTER HOUSING CYLINDER
AMMR-302	.25-.25 NPTF 90°	AMMR-613	CERAMIC FILTER HOUSING CAP
AMMR-303	.25-.375 90° FEMALE TO FEMALE	AMMR-700	10-32 NYLOCK NUT
AMMR-304	.25-.25 STRAIGHT CONNECTOR	AMMR-701	16-8 FLAT WASHER
AMMR-306	.25 RED C-CLIP	AMMR-702	CHASSIS SCREW
AMMR-307	.375 RED C-CLIP	AMMR-703	PUMP MOUNT SCREW
AMMR-308	.25 SHORT RED TUBE	AMMR-704	REACTOR MOUNT SCREW
AMMR-309	.25 LONG RED TUBE	AMMR-705	CERAMIC FILTER HOUSING MOUNT SCREW
AMMR-310	.25 SHORT BLUE TUBE	AMMR-912	ZIP TIE TUBE GUIDE
AMMR-311	.25 LONG BLUE TUBE	AMMR-913A	POWER SUPPLY HOOK VELCRO
AMMR-329	BURP VALVE	AMMR-913B	POWER SUPPLY LOOP VELCRO
AMMR-404	CERAMIC FILTER HOUSING O-RING		
AMMR-405	CERAMIC FILTER O-RING		
AMMR-501	SWITCH BOARD		
AMMR-502A	PUMP		
AMMR-505	RED BINDING POST		
AMMR-506	BLACK BINDING POST		

# Exploded Diagrams

## AIR MOBILE RESCUER REACTOR EXPLODED DIAGRAM AND PARTS LIST

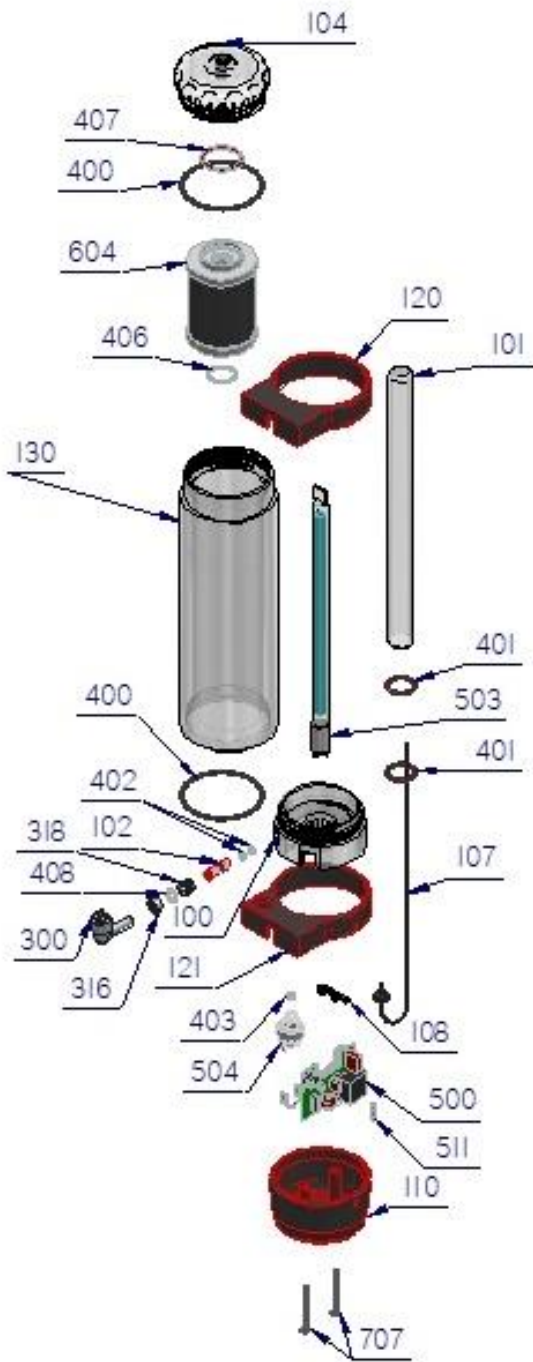

- AMMR-100 BOTTOM CAP
- AMMR-101 QUARTS SLEEVE
- AMMR-104 TOP CAP
- AMMR-107 O-ZONE CHECK VALVE
- AMMR-108 UV BULB RETAINER
- AMMR-109 VENTURI ASSEMBLY
- AMMR-102 VENTURI
- AMMR-402 VENTURI O-RING
- AMMR-110 BOTTOM COVER
- AMMR-120 TOP RING MOUNT
- AMMR-121 BOTTOM RING MOUNT
- AMMR-130 CYLINDER
- AMMR-300 .375-.25 90° MALE TO FEMALE
- AMMR-316 .375 PRESS IN RING
- AMMR-318 .375 RETAINER RING CLIP
- AMMR-400 REACTOR O-RING
- AMMR-401 QUARTS SLEEVE O-RING
- AMMR-403 PRESSURE SWITCH O-RING
- AMMR-406 CARBON FILTER-QUARTS SLEEVE O-RING
- AMMR-407 CARBON FILTER -CAP O-RING
- AMMR-408 .375 JOHN GUEST O-RING
- AMMR-500 BALLAST BOARD
- AMMR-503 UV BULB
- AMMR-504 PRESSURE SWITCH
- AMMR-511 2 AMP FUSE
- AMMR-604 CARBON FILTER
- AMMR-706 UV BULB RETAINER SCREW
- AMMR-707 BOTTOM COVER MOUNT SCREW

V3.0



# Notes



**Serial Number**

**Please Print Legibly- Important Records**

**Received by:** \_\_\_\_\_

**Organization:** \_\_\_\_\_

**Address:** \_\_\_\_\_

\_\_\_\_\_

\_\_\_\_\_

\_\_\_\_\_

**Phone:** \_\_\_\_\_

**Mobile:** \_\_\_\_\_

**Fax:** \_\_\_\_\_

**Email:** \_\_\_\_\_

**Signature:** \_\_\_\_\_

**Date:** \_\_\_\_\_

Air Mobile Ministries  
P.O. Box 406 Sneedville, TN 37869  
321-544-7757  
Website-[airmobile.org](http://airmobile.org)  
E-Mail-[airmobilejoe@gmail.com](mailto:airmobilejoe@gmail.com)

