

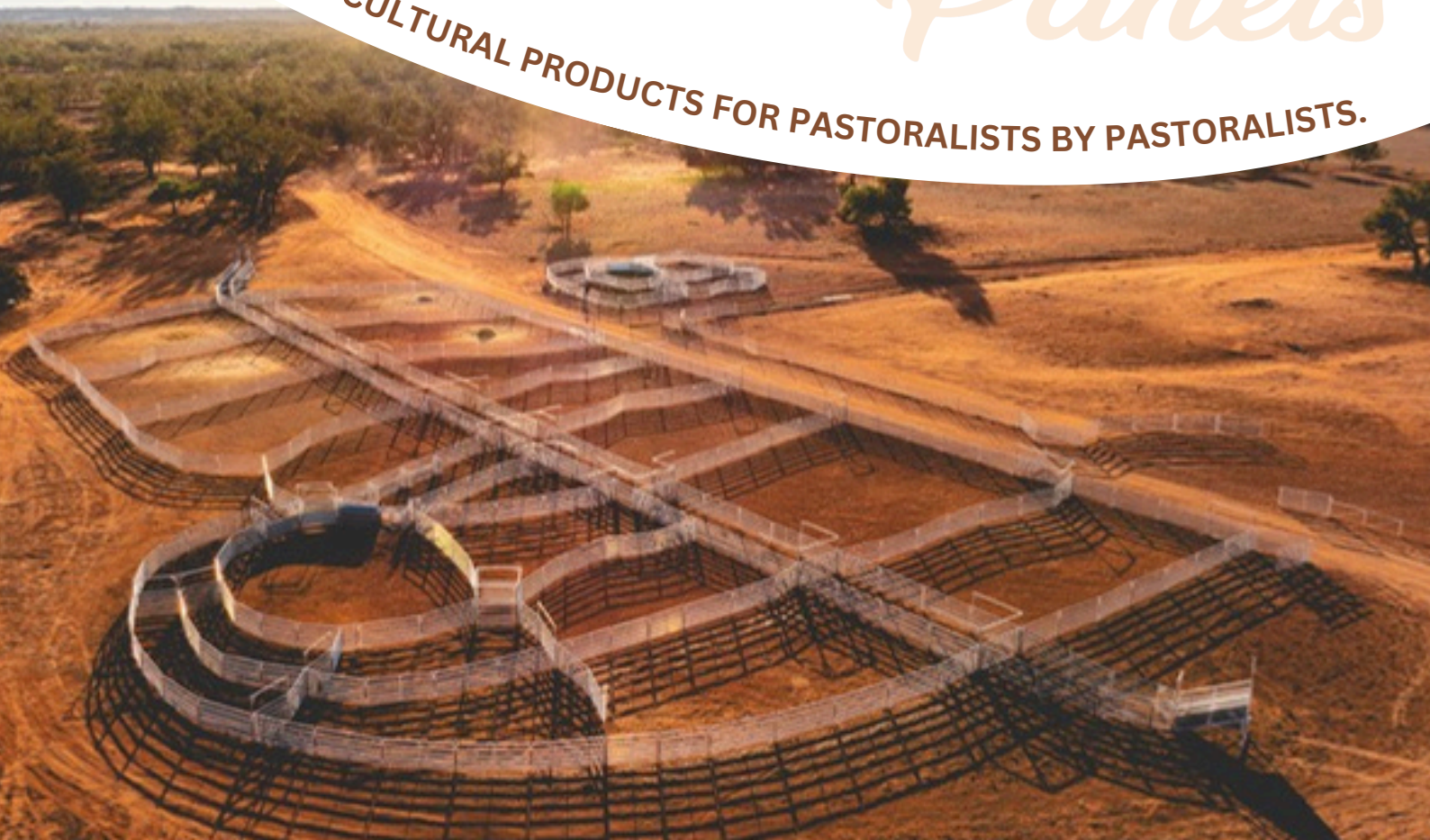

YARD KITS · LOADING RAMPS · FEEDERS

# PASTORAL PANELS PRODUCT GUIDE

AGRICULTURAL PRODUCTS FOR PASTORALISTS BY PASTORALISTS.





# CONTENTS

About Pastoral Panels.....	2
Key Features.....	4
Sheep and Goat Products.....	7
Sheep And Goat Yard Kits.....	9
Base Yard Kit Layouts.....	11
Custom Yard Kits.....	26
Heavy Duty Products.....	29
Standard, Economy and Portable.....	34
Drafting and Handling Modules.....	36
Heavy Duty Grain And Hay Feeders.....	39
Grain Feeders.....	40
Hay Feeders.....	41
Cattle Products.....	43
Cattle Yard Kits.....	44
Base Yard Kit Layouts.....	47
Heavy Duty Cattle Panels.....	54
Cattle Handling Products.....	55
Loading Ramps.....	58
Horse Round Yards.....	62
Delivery and Stockists.....	65

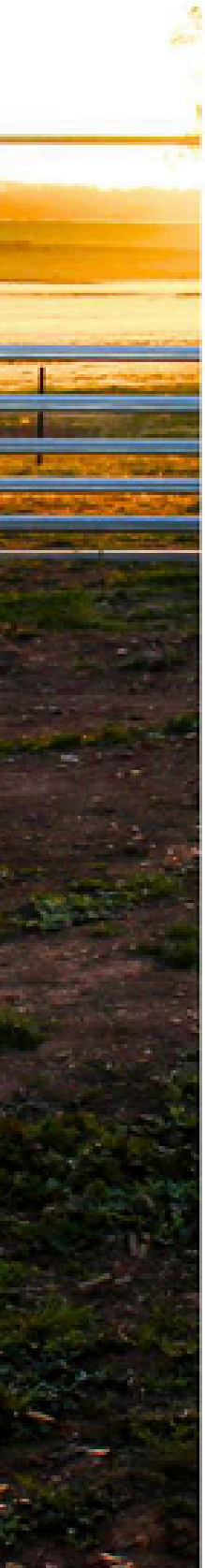

## About Pastoral Panels

Based in Mildura, Victoria, Pastoral Panels is 100% Australian owned and operated. Pastoral Panels designs and supplies permanent and semi-permanent stock yard kits, feeders and loading ramps for all sizes of stock operations.

Designed, tested and refined by pastoralists, we understand the importance of reliable, safe and efficient yard designs. Our products are created with user ease and efficient stock flow in mind, while being fast and simple to assemble with no welding or concreting required for our semi-permanent range. Built to last in the harshest of Australian environments, only the toughest heavy-duty materials have been selected to construct our products.

At Pastoral Panels, we strive to provide farmers with high-quality, cost-effective stock yard kits. Whether you need a small or large yard kit, with our flexible options, we have you covered. We strive to meet the needs of our clients, with custom-made designs and the ability to integrate any of our heavy-duty products into a layout that works for you.

With delivery available and distributors located strategically through Queensland, Victoria, South Australia, and New South Wales, it's never been easier to get your ideal yard kit installed.



## KEY FEATURES

### Sliding Latches

Our gates are fitted with easy-to-use sliding latches that allow quick and safe access. The latches sit flush against the gate for operator convenience and enhanced stock protection. Designed as cam locks, they are stock-proof and remain firmly secured unless deliberately lifted and twisted. Unlike traditional slam latches, they won't spring open under pressure from stock, ensuring dependable performance at all times.

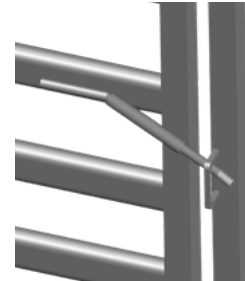

### Foot Plates

The unique hot dipped galvanised foot plate on our panels keeps the bottom rail up and out of the mud, keeping your yards clean and maintaining the longevity of the steel.

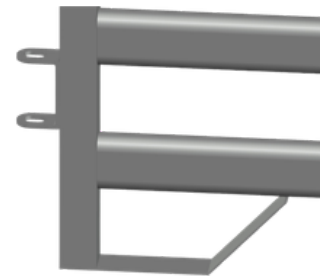

### Diamond Yards

Incorporating diamond yards into all our yard kit designs greatly improves the efficiency of livestock handling. Their versatile layout allows for smooth, controlled movement of animals, minimising the need for constant reshuffling.

This efficiency not only saves time but also reduces stress on the stock.

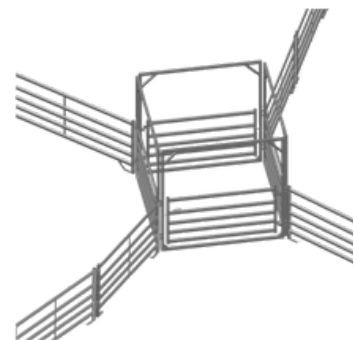







SHEEP AND GOAT PRODUCTS



## SHEEP AND GOAT YARD KITS

As Pastoralists, we understand the importance of efficient stock flow and a safe yard layout. We offer fully customisable sheep and goat yard kits that can be tailored to your specific needs. With the capacity to handle anywhere from 50 to 30,000 head of stock, our yard kits can be configured as permanent or semi-permanent systems to suit your operation.

Our easy-to-assemble yard kits are made from heavy-duty galvanised steel, providing exceptional durability against all breeds and sizes of sheep and goats. The oval rails are highly visible to stock, promoting smooth movement through the yards and reducing the risk of animals running into the rails.

All high-use gates are fitted with sliding latches that require no chains, allowing quick and safe access. Optional man gates can also be included at key access points for added convenience. Our three- and four-way drafts are designed to accommodate all sizes of sheep and goats, including full-wool Merinos.

Custom layouts can be created on request, enabling your yard kit to be perfectly suited to your flock and operational requirements. The result is a stock handling system that is safe, efficient, and reliable, designed to simplify your day-to-day livestock management.



## BASE KIT YARD LAYOUTS

Base yard kits are the perfect starting point for any livestock operation, designed to prioritise both operator safety and smooth stock movement.

Each kit can be supplied with either our semi-permanent heavy-duty panels and gates or our standard range, giving you flexibility to suit your needs.

For a long-term solution, base yard kits are also available in a fully permanent configuration. Contact us today to discuss installation options.



**200 HEAD SEMI-PERMANENT**  
Approx Area: 133.9m<sup>2</sup>

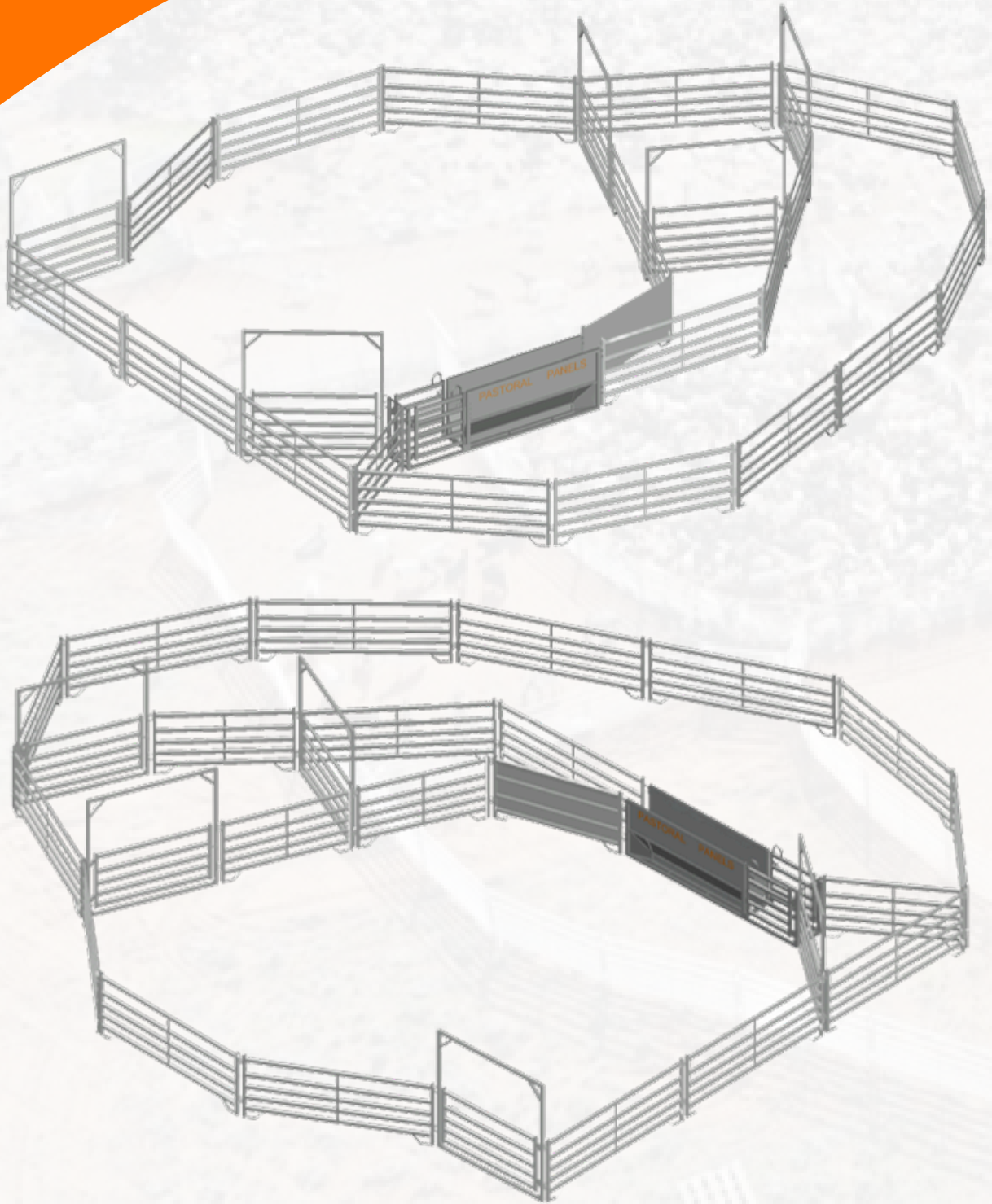

**280 HEAD SEMI-PERMANENT**  
Approx Area: 140.2m<sup>2</sup>

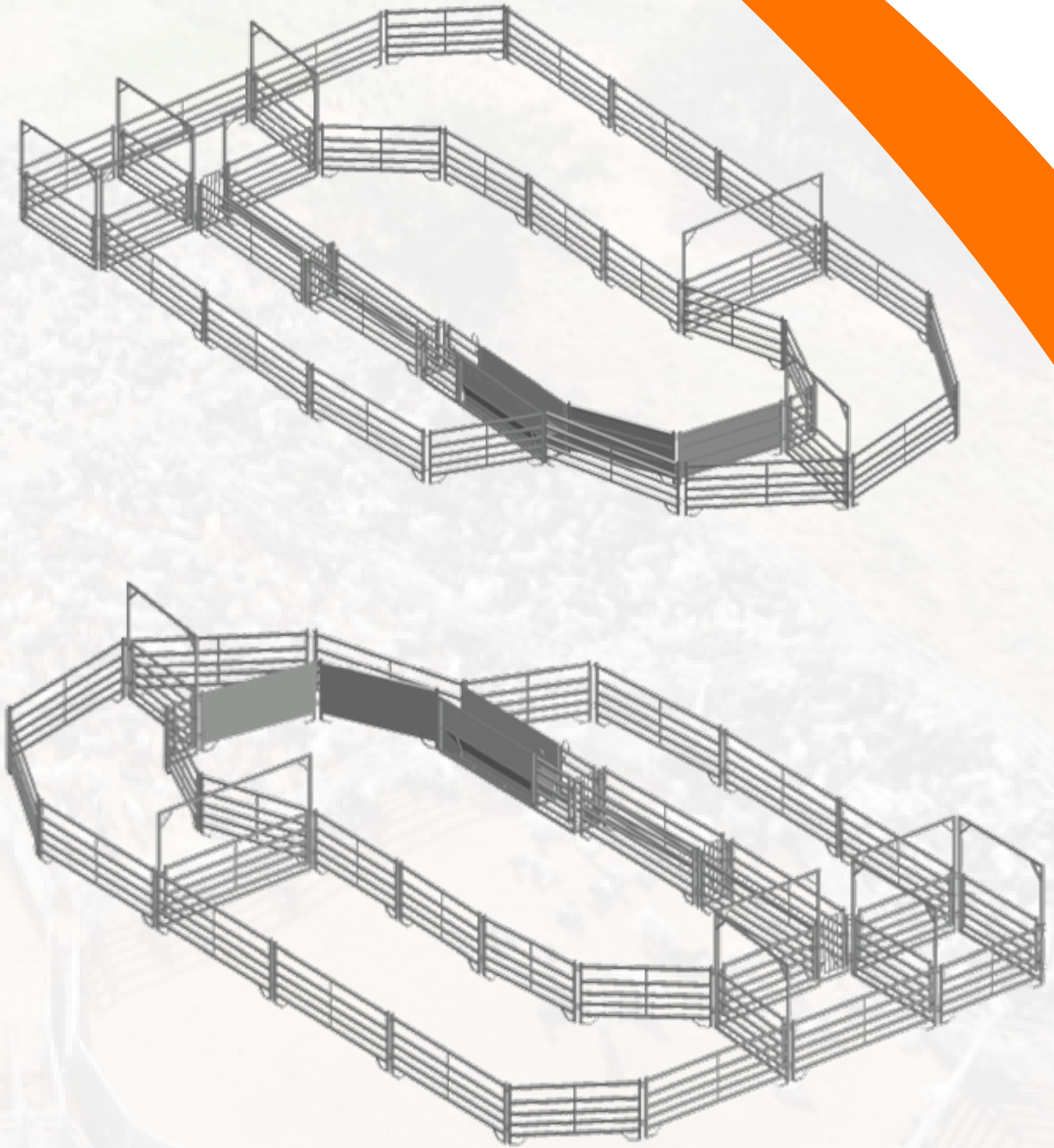

**500 HEAD SEMI-PERMANENT**  
Approx Area: 243m<sup>2</sup>

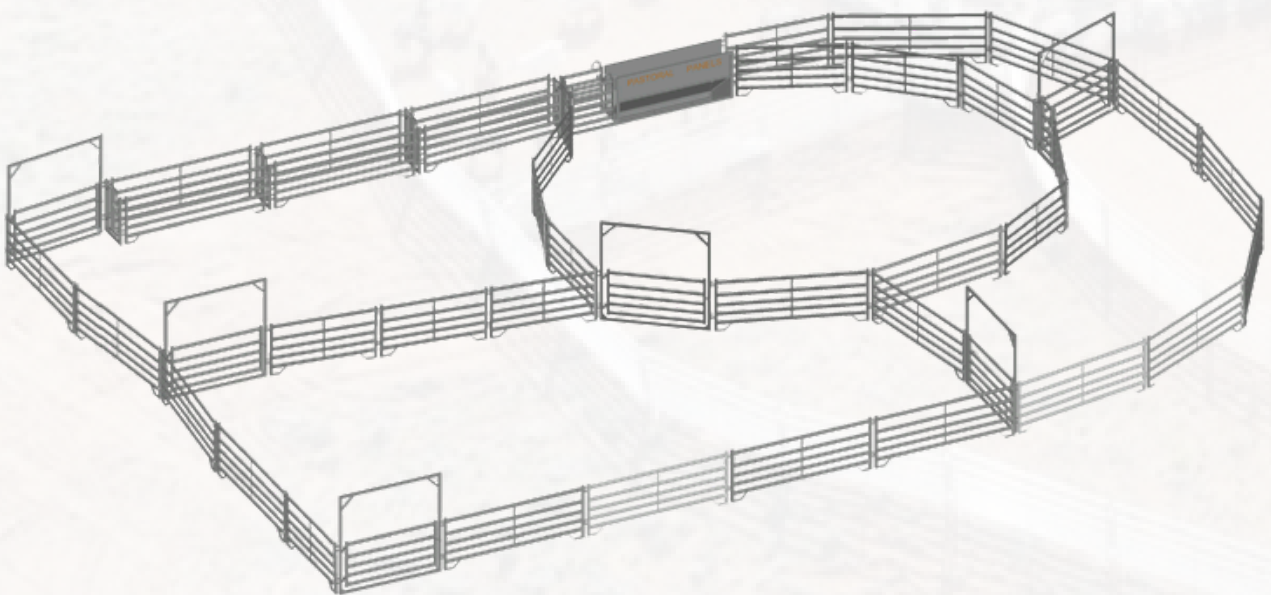
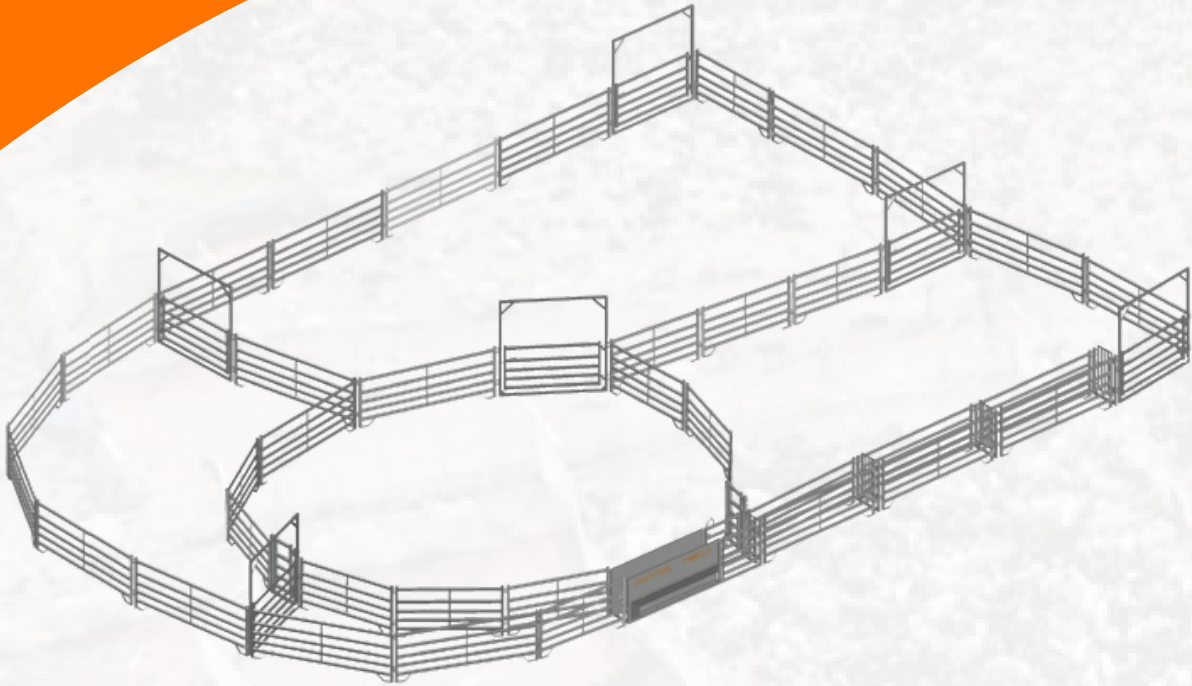

**600 HEAD SEMI-PERMANENT**  
Approx Area: 300m<sup>2</sup>

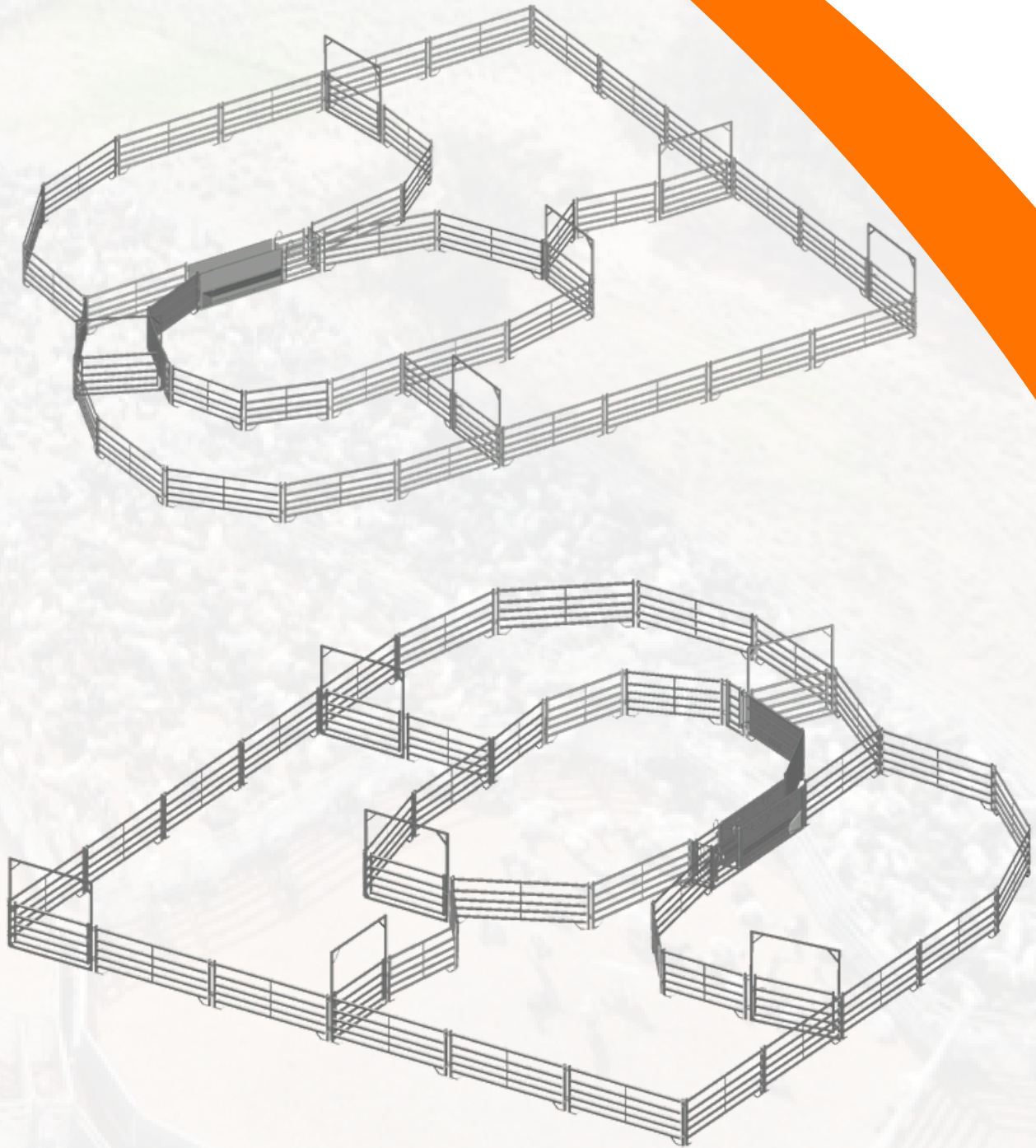

**1100 HEAD SEMI-PERMANENT**  
Approx Area: 557m<sup>2</sup>

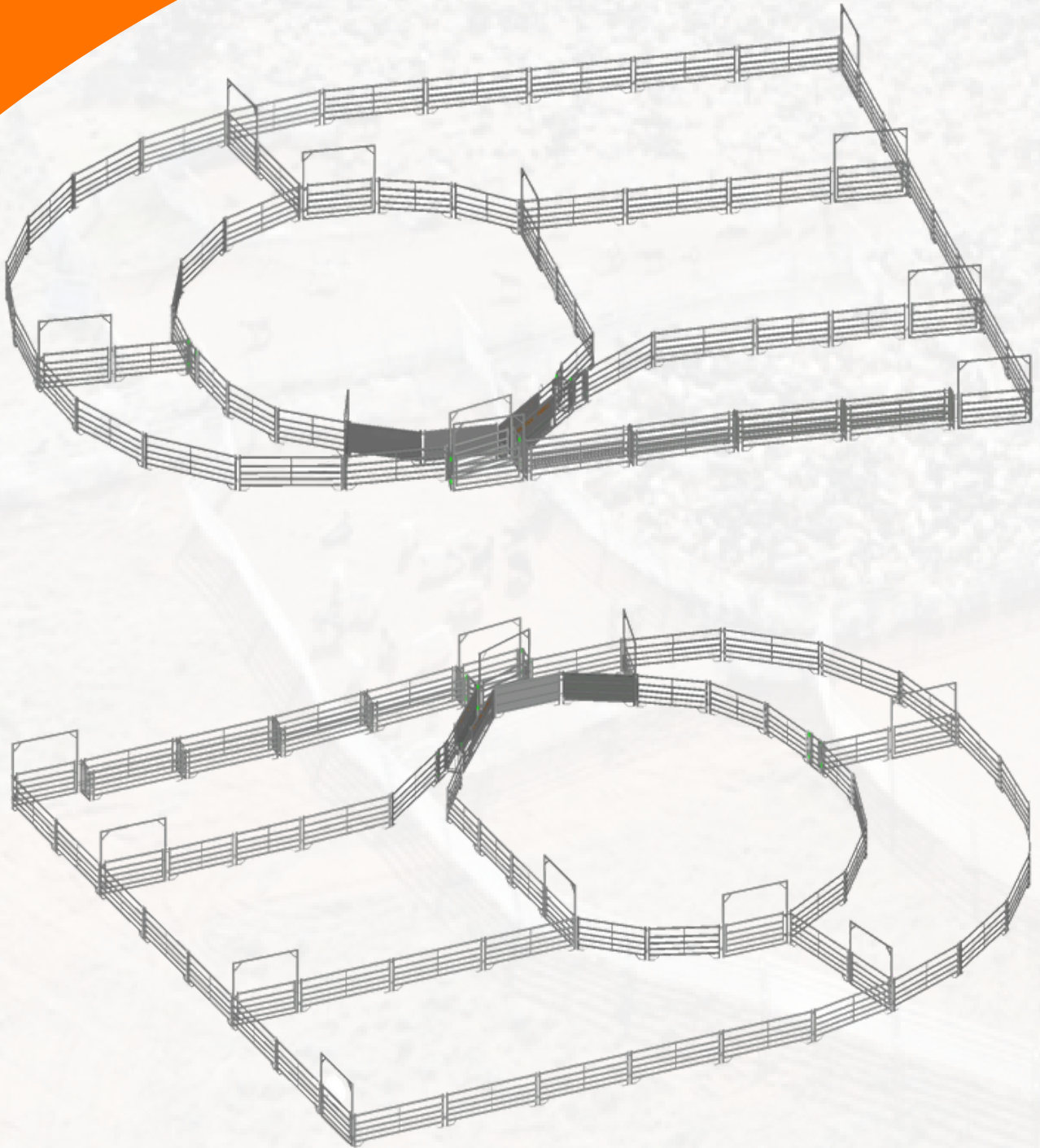

**1100 HEAD PREMIUM SEMI-PERMANENT**  
Approx Area: 577m<sup>2</sup>

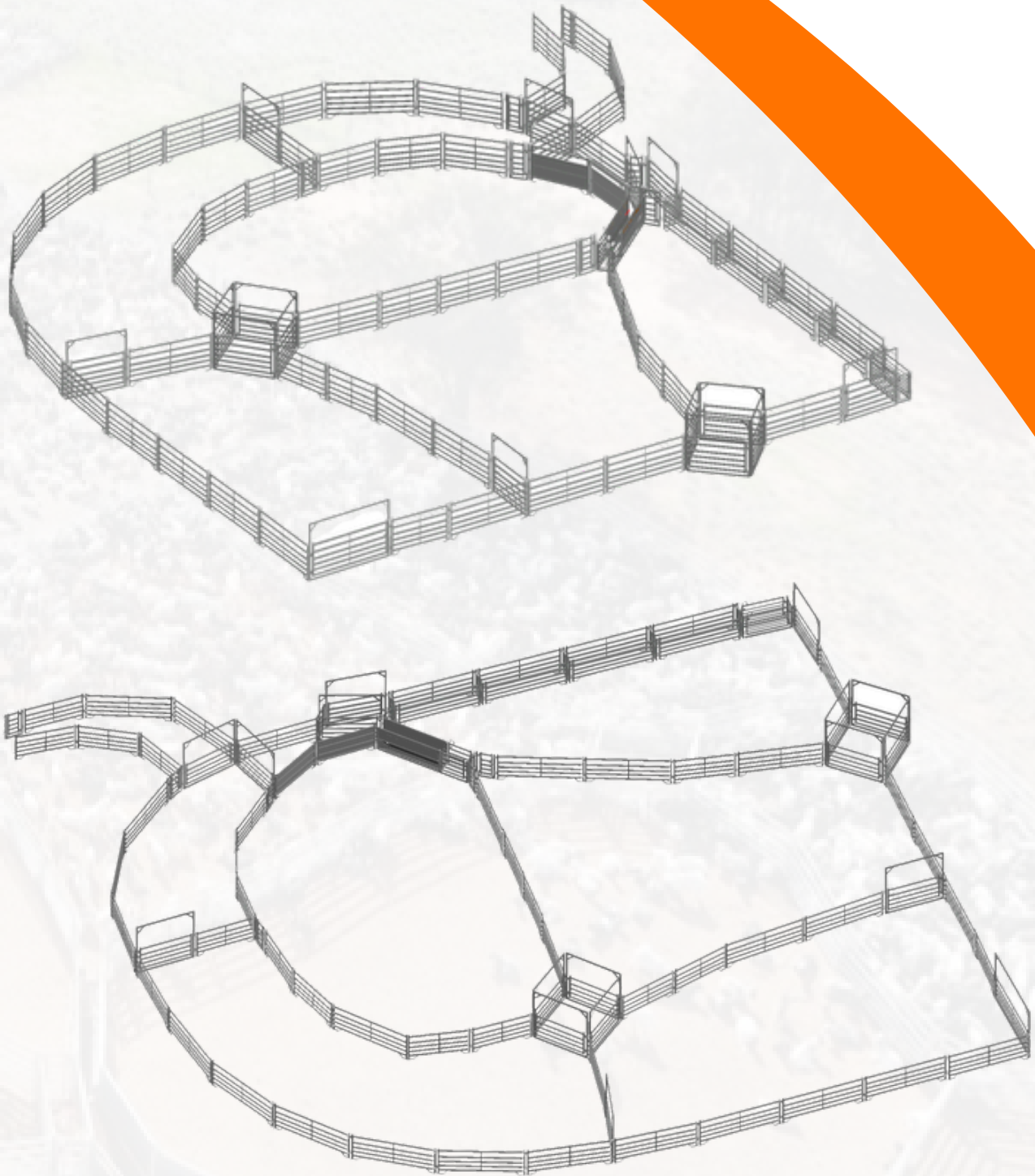

**1500 HEAD SEMI-PERMANENT  
COMBO YARD KIT**  
Approx Area: 708m<sup>2</sup>

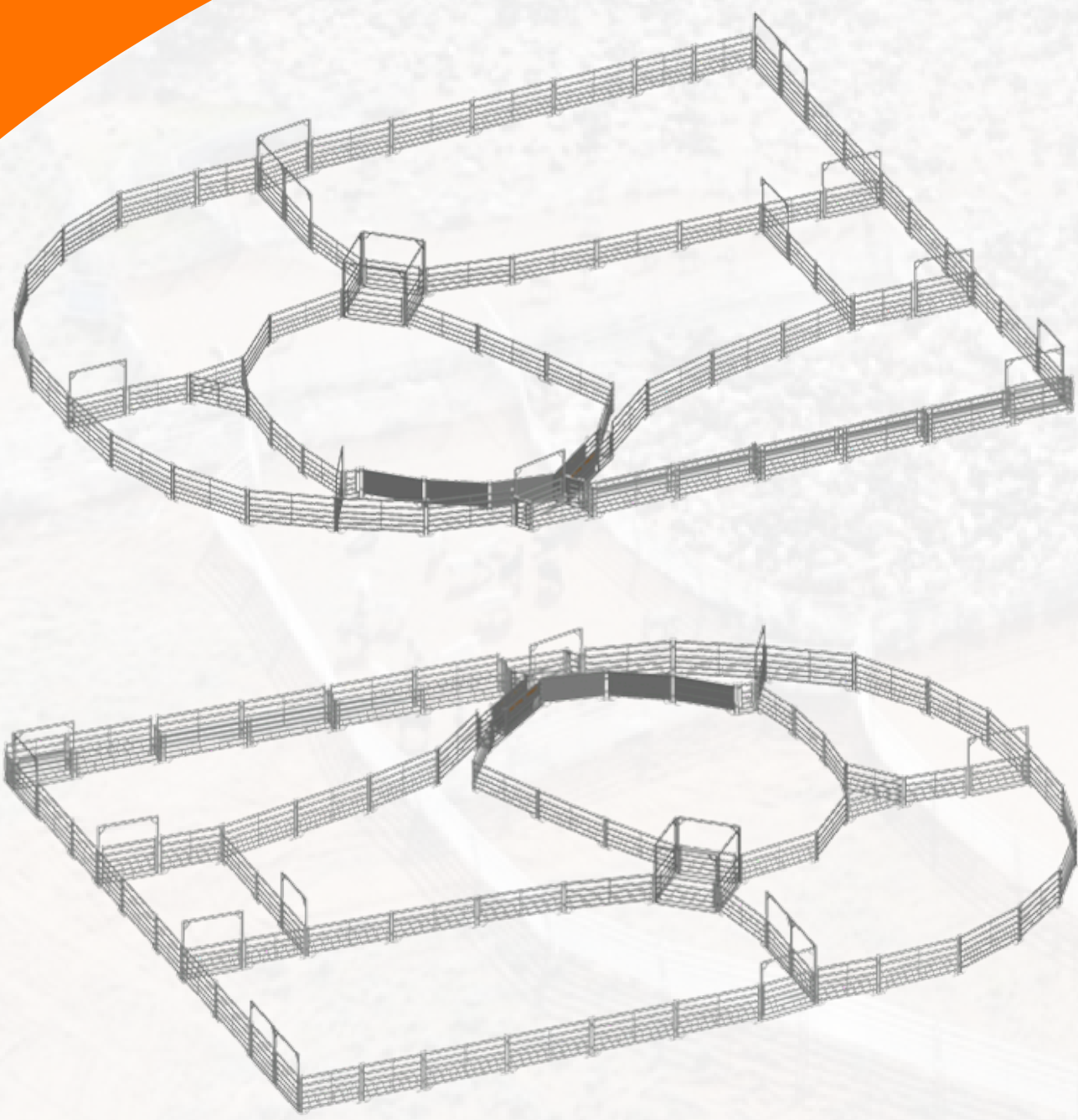

**1800 HEAD SEMI-PERMANENT**  
Approx Area: 904m<sup>2</sup>

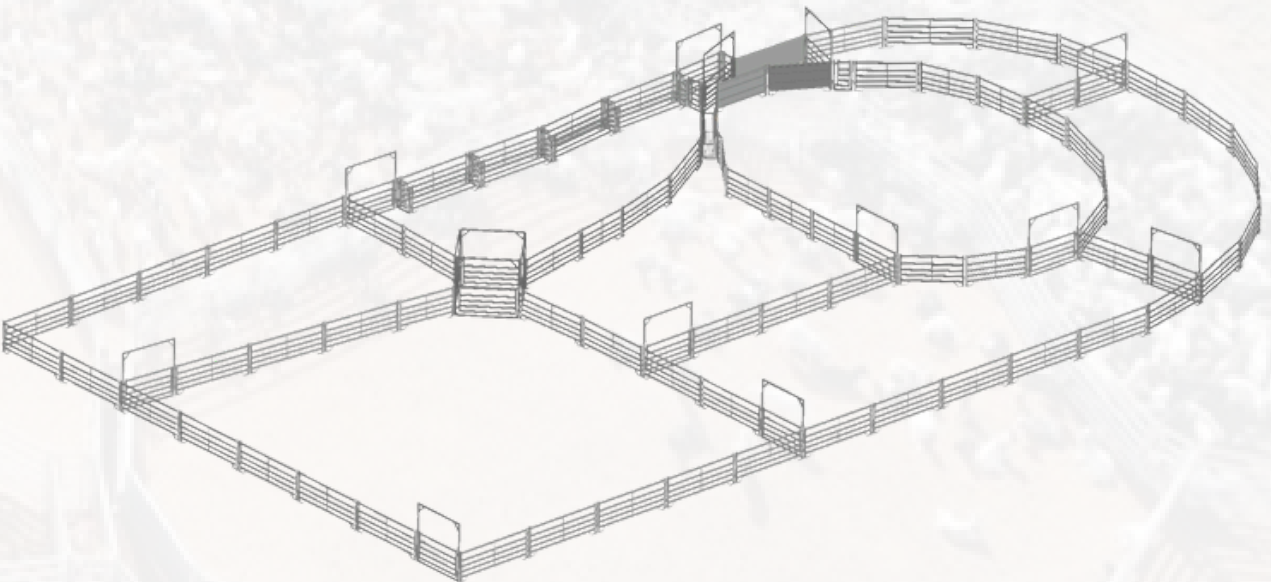

**1800 HEAD PREMIUM**  
**SEMI-PERMANENT**  
Approx Area: 918m<sup>2</sup>

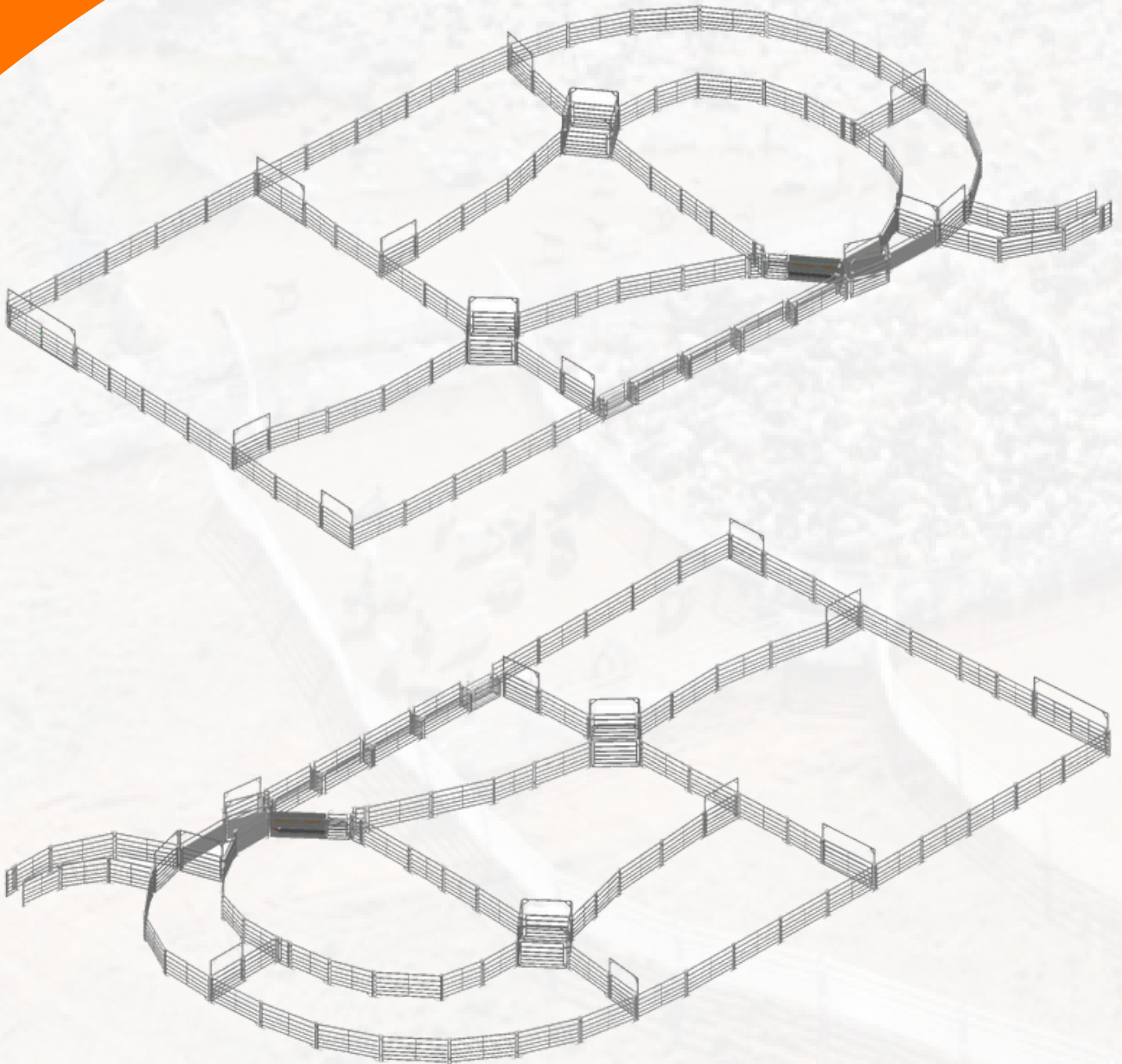

**2200 HEAD SEMI-PERMANENT**  
Approx Area: 1149m<sup>2</sup>

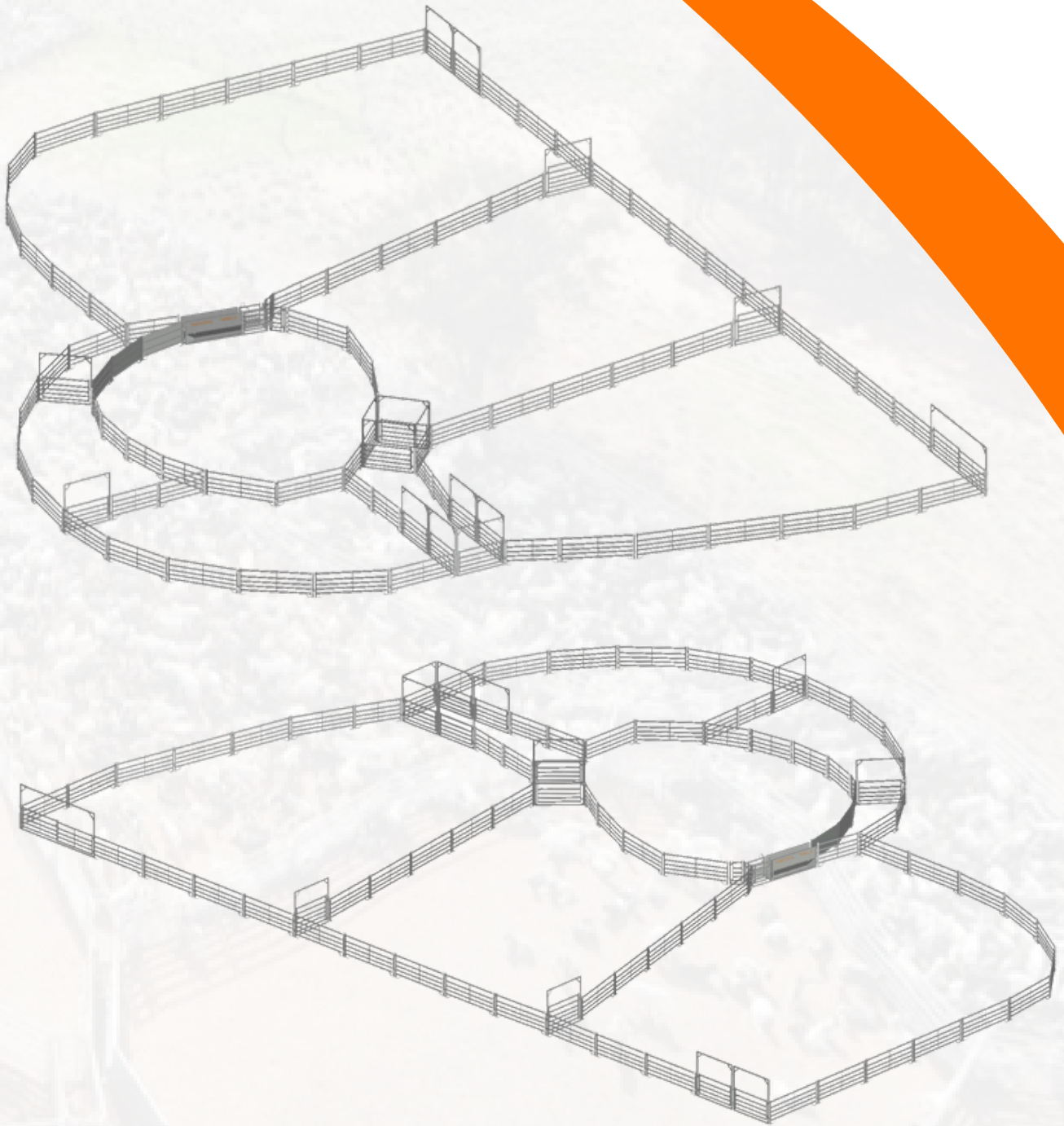

**3800 HEAD SEMI-PERMANENT**  
Approx Area: 1826m<sup>2</sup>

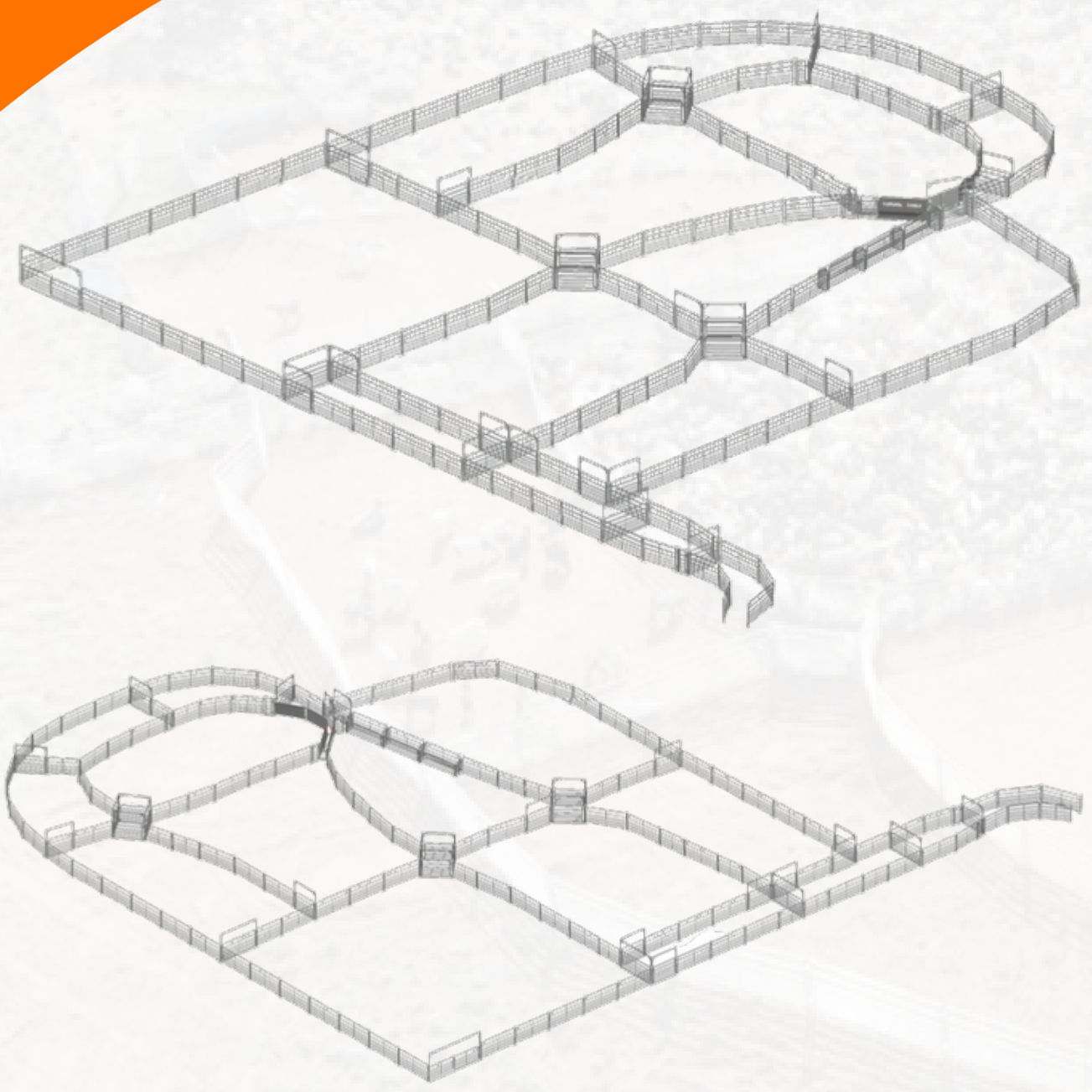

**4000 HEAD SEMI-PERMANENT**  
Approx Area: 1983m<sup>2</sup>

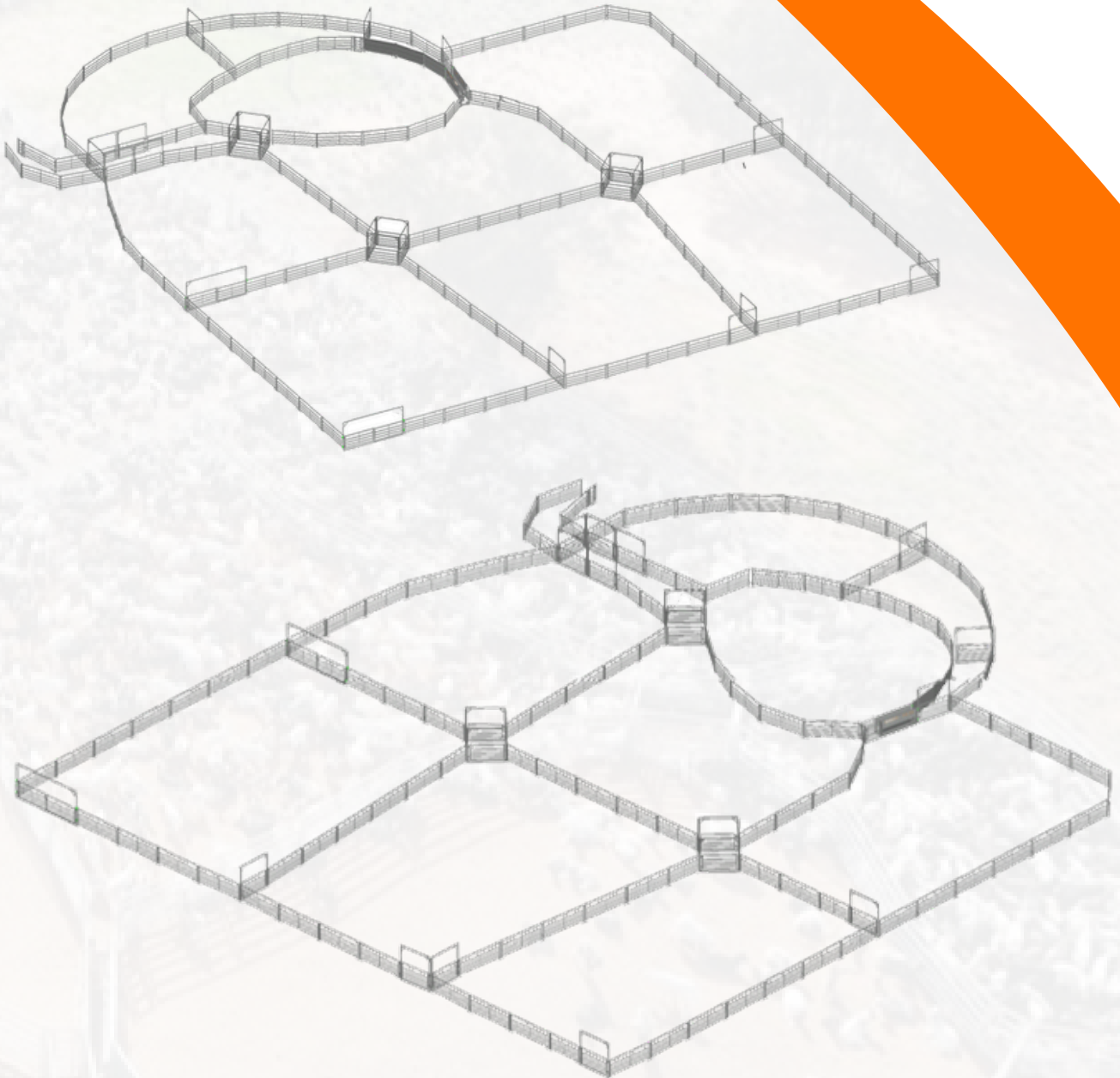





## CUSTOM YARD KITS

At Pastoral Panels, we recognise that every sheep and goat operation is unique, with specific requirements and operational challenges. That is why we offer fully custom-designed yard solutions, tailored to meet the precise needs of your operation.

Whether you require permanent, semi-permanent, or portable yards, our experienced yard design team will develop a solution that integrates seamlessly with your operation. Using advanced CAD drawings, we provide a detailed visualisation of your proposed yard layout, ensuring every aspect is planned to optimise stock flow, safety, and efficiency.

Our design process takes into account flock size, breed, and any operational factors that may influence stock management, enabling us to create a yard that is both practical and durable. With a Pastoral Panels custom-designed yard, you can have confidence that your infrastructure will meet your specific requirements while fitting harmoniously within your existing setup.

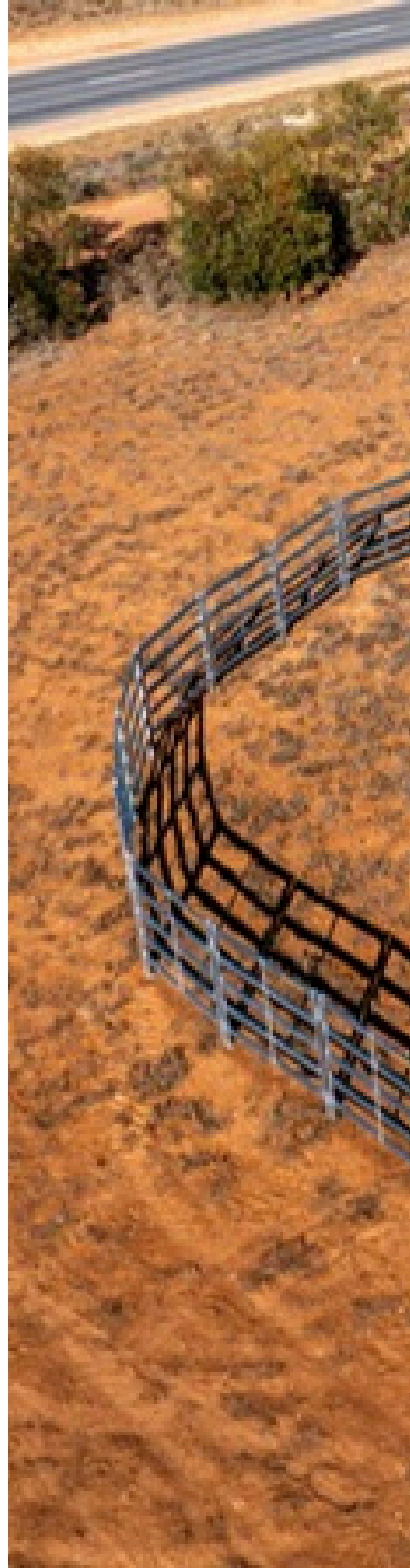





## HEAVY DUTY SHEEP AND GOAT PRODUCTS

Our heavy-duty panels are constructed with 50×50mm vertical posts and 40×80mm oval cattle rails, providing enhanced visibility for livestock and supporting safer stock handling. Each panel features a substantial 200mm hot dipped galvanised foot plate at either end, preventing sinkage in sand or mud and ensuring stability in all conditions.

Pastoral Panels gate frames are engineered for superior strength and durability. Incorporating an overhead frame and corner brackets at all four corners, they provide double the strength of standard sheep or goat yard gates, ensuring livestock remain secure.

We offer a comprehensive range of yard components that can be integrated into your kit design, including in-frame gates, handling races, drafts, and man gates. Alternatively, these items can be purchased individually. Whatever your requirements, our expertise and experience allow us to deliver high-quality, durable, and practical solutions tailored to your operation.



## HEAVY DUTY SHEEP AND GOAT PANELS

### Heavy Duty Goat Panels

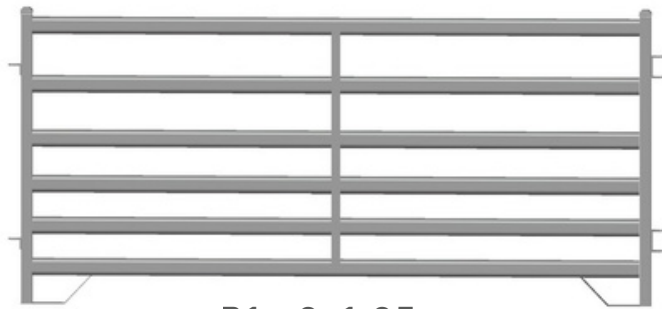

P1 - 3x1.35m

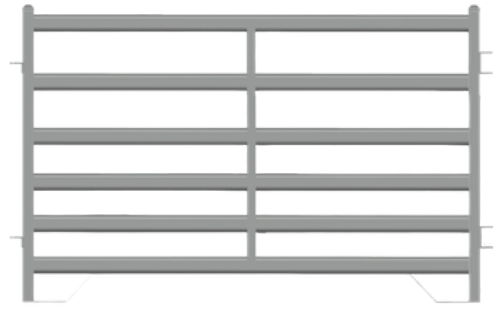

P2 - 2.2x1.35m

### Heavy Duty Sheep Panel

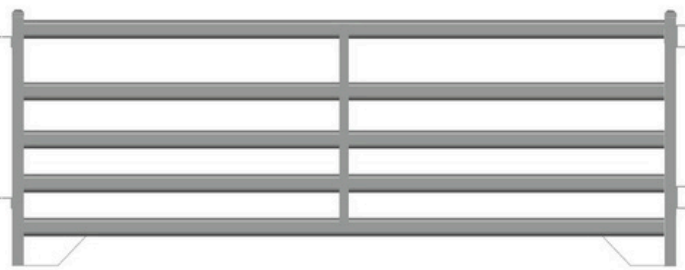

S1 - 3x1.1m

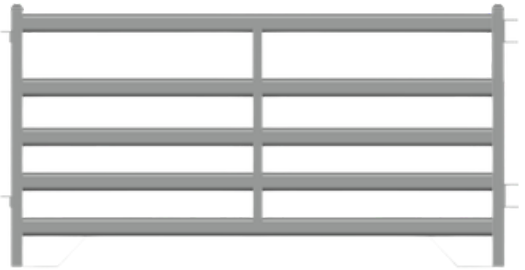

S2 - 2.2x1.1m

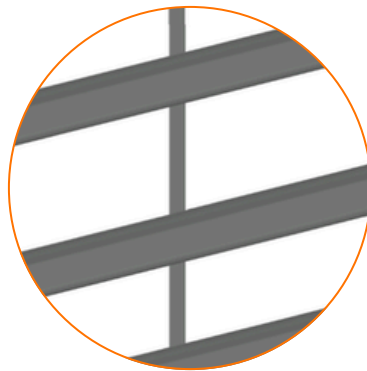
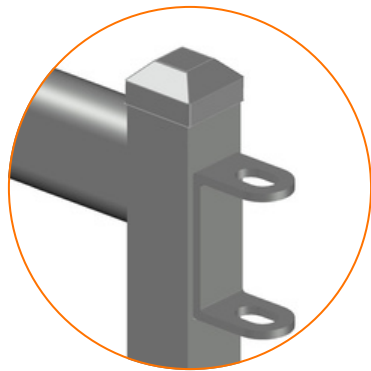

### Handling Race Panel



SRP1 - 3x1m

# HEAVY DUTY SHEEP AND GOAT GATES

## Heavy Duty In Frame Goat Gates

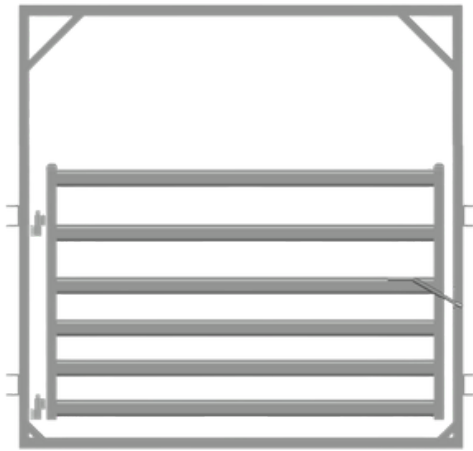

G1 - 2.2x1.35m

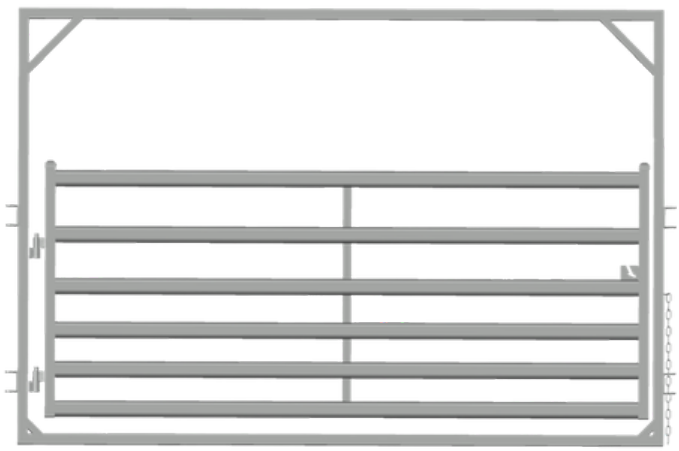

G2 - 3.0x1.35m

## Heavy Duty In Frame Sheep Gate

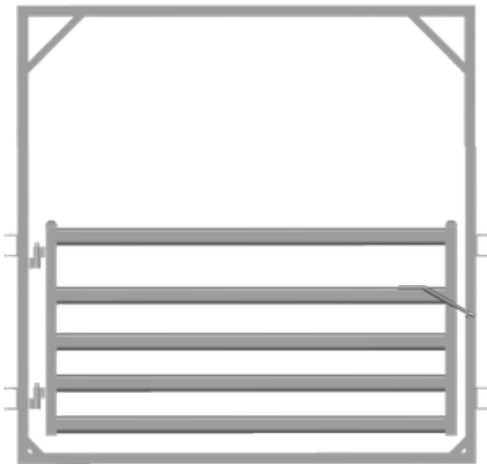

SG1 - 2.2x1.1m

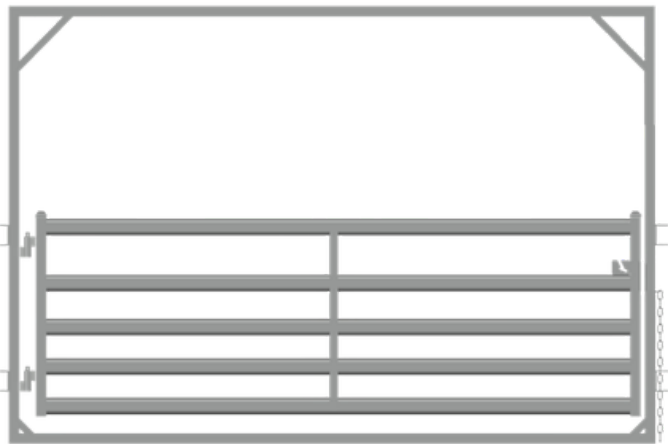

SG2 - 3.0x1.1m

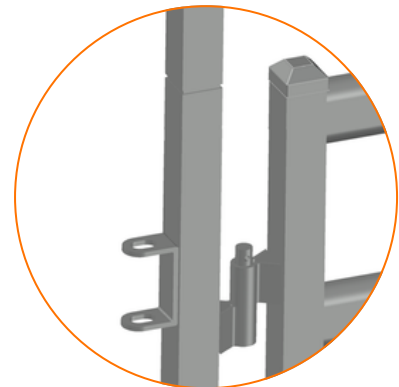
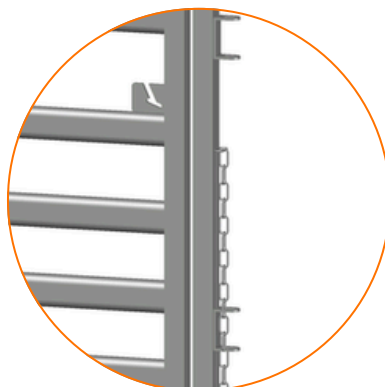
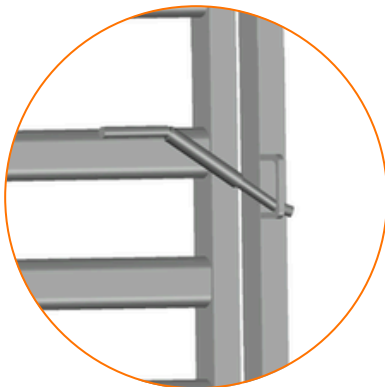

## HEAVY DUTY DOUBLE GATES

Double In Frame Goat Gate

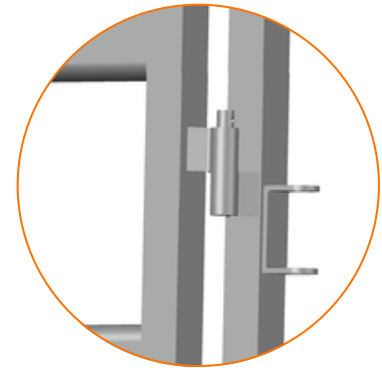

G3 - 4.4x1.35m

Double In Frame Sheep Gate

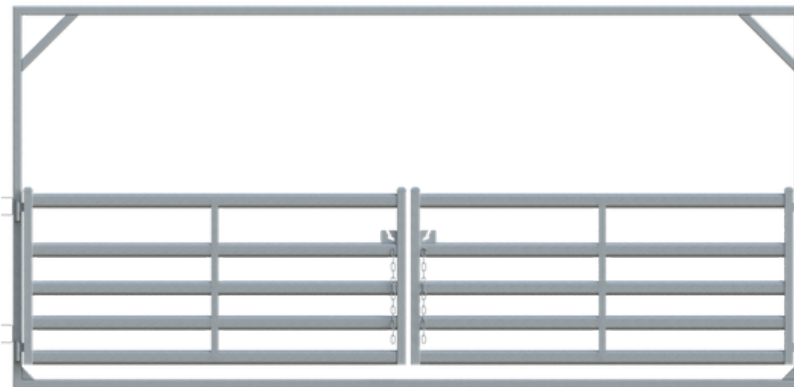

SG3 - 4.4x1.1m

Heavy Duty Double Cattle Gate

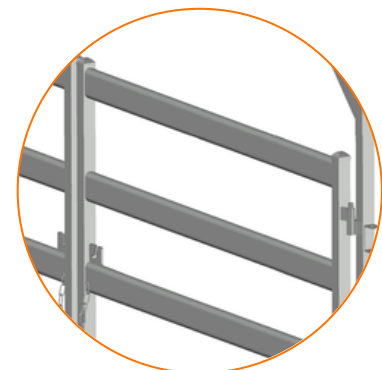
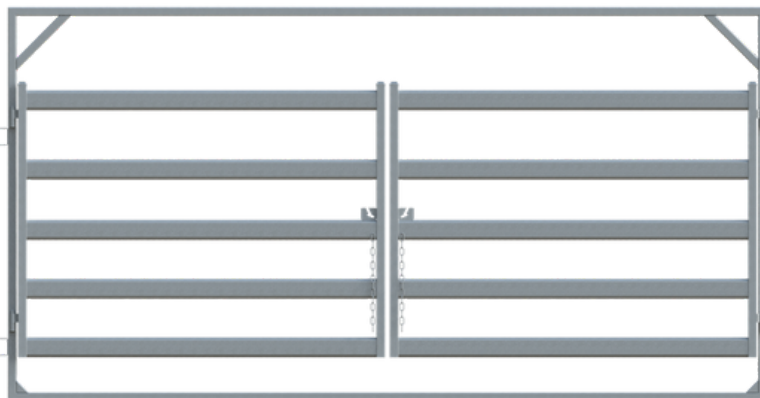

HDCG3 - 4.4x1.8m

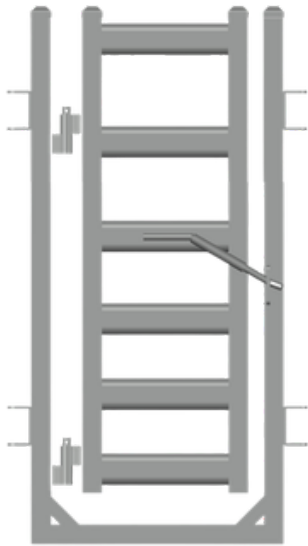

MG1 - Man Gate Goat

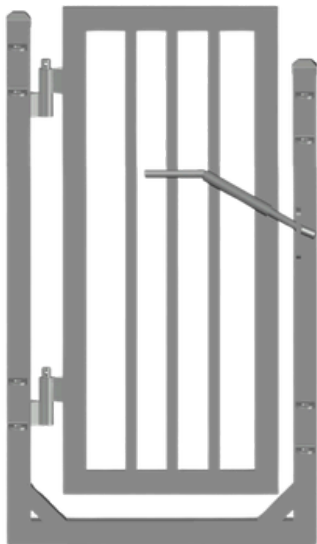
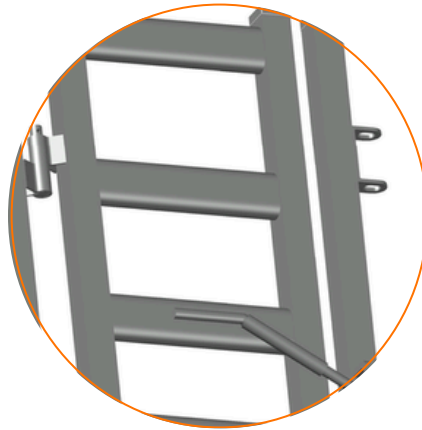

SRG1 - Sheep Race Gate Narrow

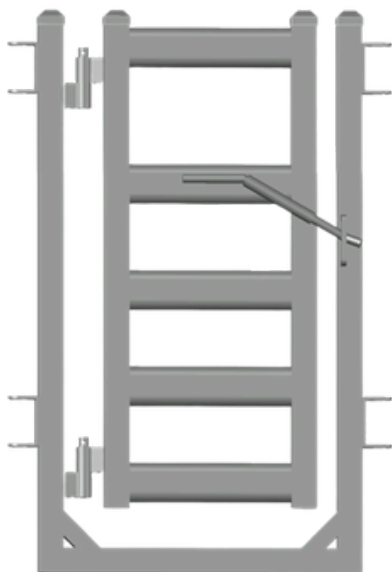

MG2 - Man Gate Sheep

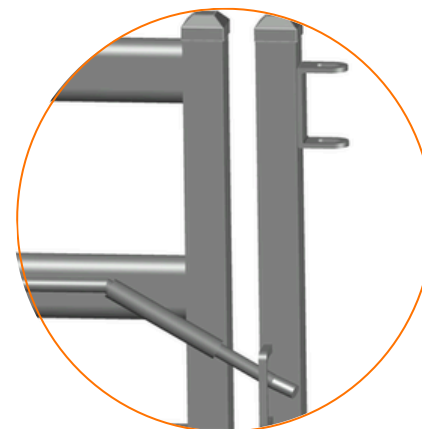

## STANDARD, ECONOMY AND PORTABLE PANELS

Economy Sheep Panel

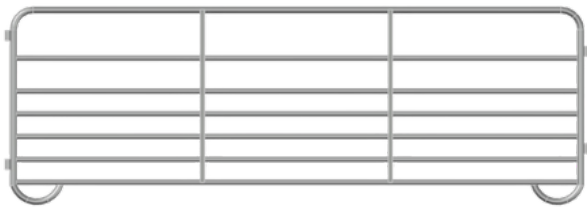

ESP1 - 2.9m x 1m

Standard Sheep Panel



SSP1 - 3x1m

Economy Goat Panel

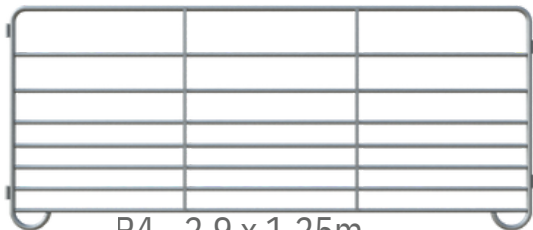

P4 - 2.9 x 1.25m

Standard Goat Panel

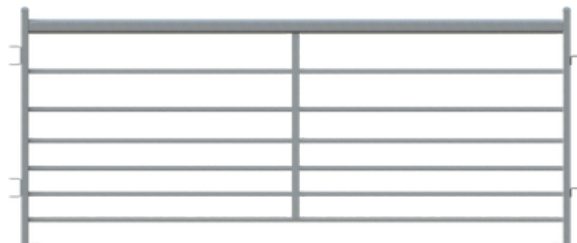

P5 - 3 x 1.25m

Portable Goat Panel

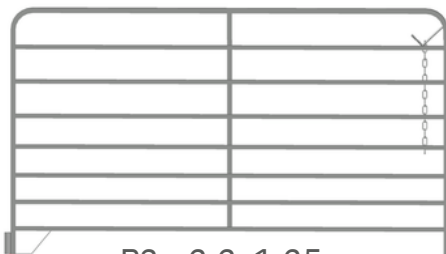

P3 - 2.2x1.25m

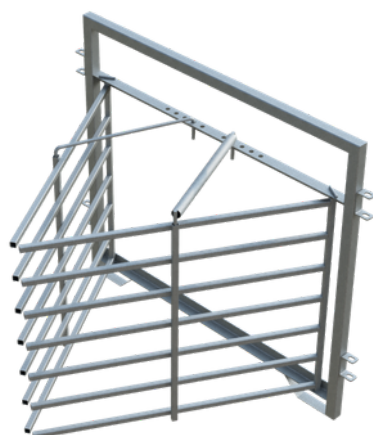
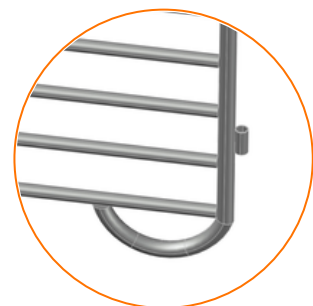

Portable Goat Trap  
GT1 - 1.7m x 1.35m

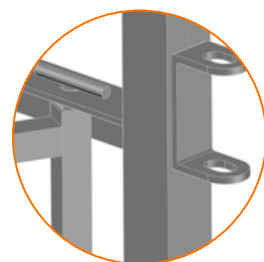
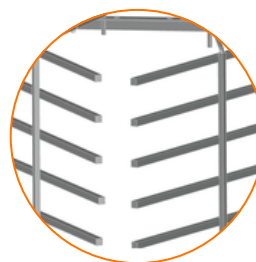



# SHEEP AND GOAT DRAFTING AND HANDLING MODULES

D1 - 3.6m 3-Way Standard Draft

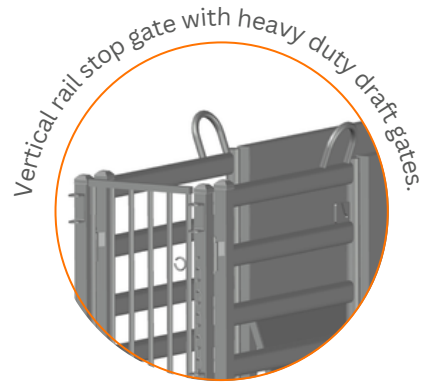

D4 - 4.2m 3-Way Long Draft



D6 - 4.2m 4-Way Draft

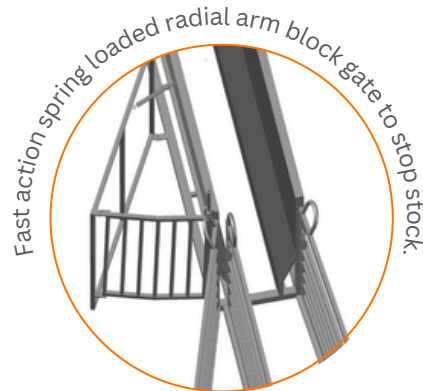
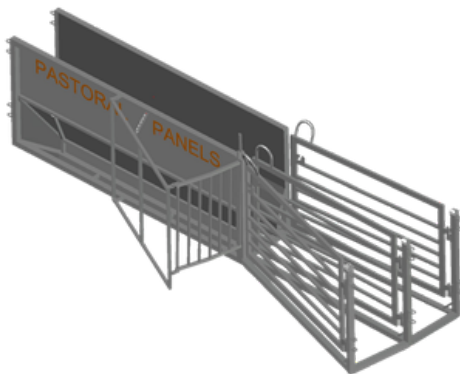

Handling Race

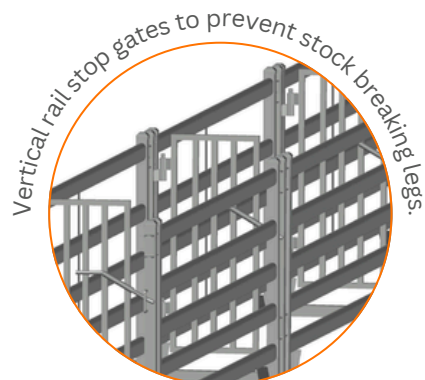
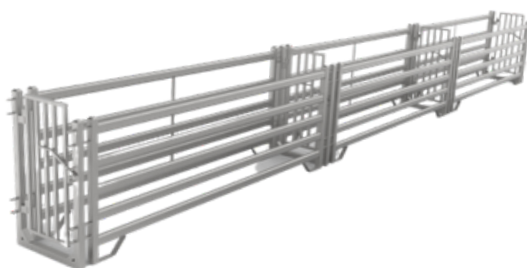







PANELS

28 108 970

HEAVY DUTY GRAIN & HAY FEEDERS

## GRAIN FEEDERS GF1A

The 3500L Heavy Duty Grain Feeder is engineered for durability, reliability, and long-term performance. Constructed with 50x70x4mm heavy-duty skids, it provides exceptional structural strength and stability.

Designed to protect feed quality, the pitched roof prevents water pooling, keeping grain and pellets dry. The hinged lid opens to 100 degrees, providing full access for efficient filling while minimising spillage, and offers a safer alternative to conventional sliding lids.

The hopper and trough are formed from 2mm galvanised sheet steel, allowing the feeder to withstand high-capacity auger filling. For operations requiring lick feeding, an optional bolt-in slide can be fitted to the base of the trough, and additional accessories—including gas struts for assisted lid opening and sight glasses—are available upon request.

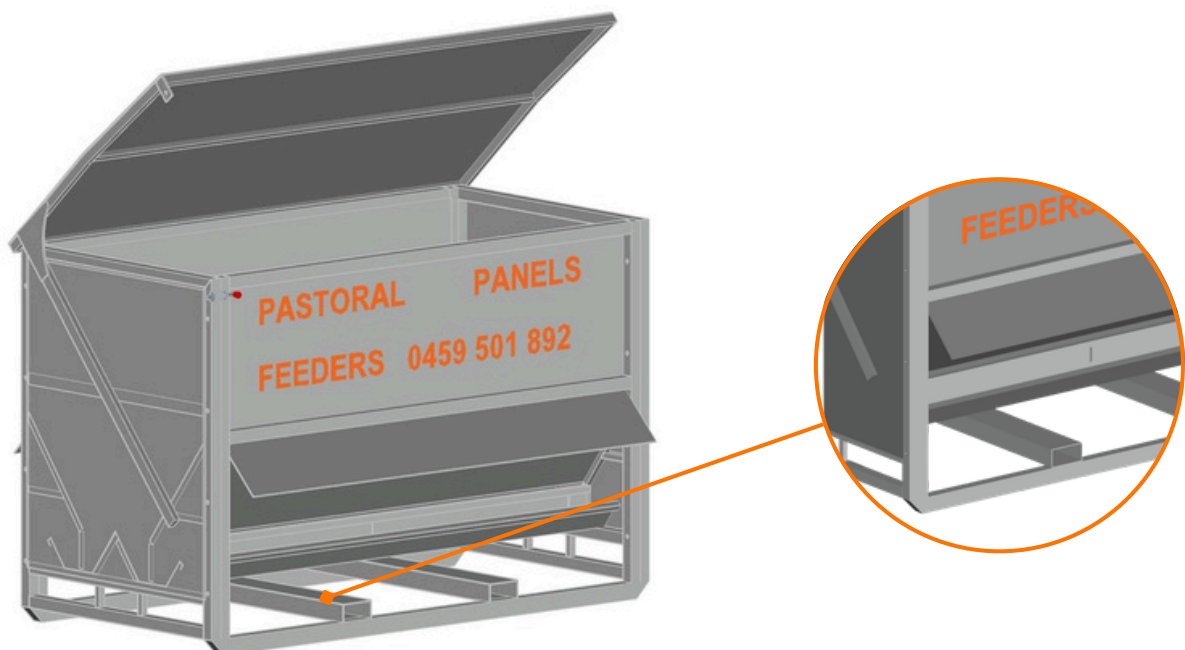

## HAY FEEDERS

Pastoral Panels hay feeders are purpose-built to provide a reliable, long-lasting feeding solution for multiple livestock species, including goats, sheep, cattle, and horses, while minimising feed waste and maintenance requirements.

Constructed from high-quality galvanised 65×65×2mm RHS steel, the robust frame is designed to resist bending or structural fatigue, even under the weight of large, heavy bales. This superior construction ensures long service life while providing a cost-effective, low-maintenance feeding solution for diverse livestock operations.

In addition to durability, Pastoral Panels hay feeders can save up to 25% of each bale per feed. Over time, this significantly reduces waste and maximises feed utilisation, ensuring every bale delivers greater value and efficiency for your operation.

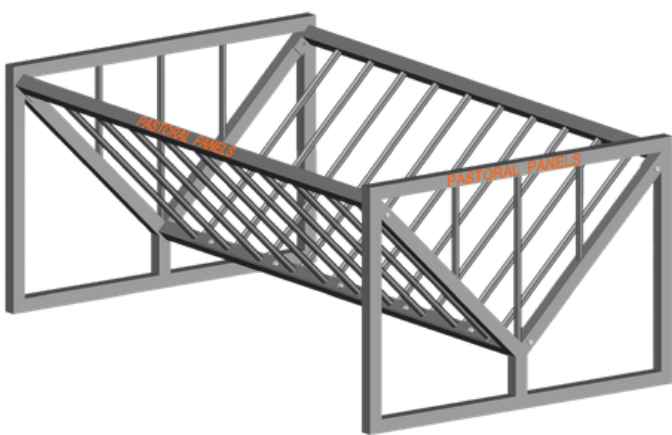

HF1 - Squat Hay Feeder

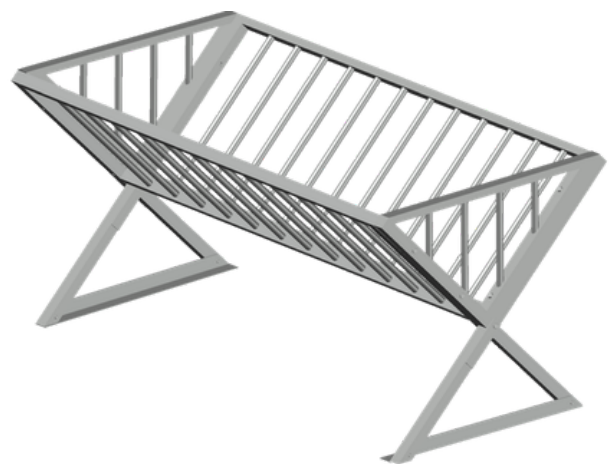

HF2 - X Hay Feeder





CATTLE PRODUCTS

## CATTLE YARD KITS

Our yard kit designs are centred on efficient stock flow, operator safety, and practical functionality. Recognising the challenges of cattle handling, we offer fully customisable yard systems capable of accommodating operations ranging from 10 to 10,000 head of cattle.

As every livestock operation is unique, tailored designs are available upon request. Additional gates, walkways, or alternative layouts can be incorporated to suit specific requirements, ensuring each yard is optimised for its intended use. Our commitment to quality ensures a reliable, long-term solution.

The panels are manufactured from heavy-duty steel and designed for high visibility to livestock, enhancing both safety and handling efficiency. Gate frames are engineered to provide double the strength of standard cattle yard gates, improving operator safety, animal control, and stock flow.

Suitable for all cattle breeds, our panels deliver durable, reliable stock management solutions. We offer heavy-duty cattle yards with 115 × 42 mm oval rails for maximum strength and security, and standard yards with 40 × 80 mm oval rails for a cost-effective yet durable handling option.

**Talk to our dedicated stock yard design team to create the perfect solution for your operation.**





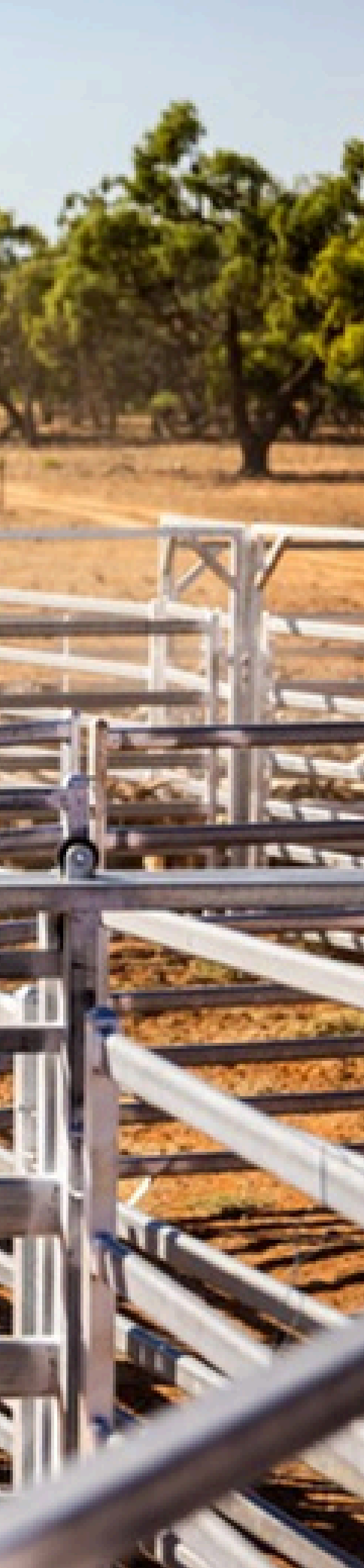

## Base Kit Yard Layouts

Our yards can be configured as permanent or semi-permanent systems to suit the specific needs of your operation. Constructed from heavy-duty steel, the panels are highly visible to livestock and designed to protect both cattle and operators. Their robust build minimises injury during handling, while strong, stable gates and rails ensure secure containment in all conditions.

To complement your setup, we offer several ramp options—from standard models through to 6m side-load ramps with optional walkways and man gates for enhanced user safety—along with manual 3- and 5-way drafts fitted with baulk gates, and cattle crushes to create a complete and efficient handling system tailored to your operation.

We also offer Multi Panels designed to manage multiple species within one yard, maximising efficiency and saving space without compromising safety or flow. Engineered to be lamb-to-bull proof, they feature 7-rail 40 × 80 mm oval non-bruise rails for enhanced safety, durability, and smooth stock movement.

**55 HEAD CATTLE YARD**  
Approx Area: 132m<sup>2</sup>



**86 HEAD CATTLE YARD**

Approx Area: 190m2



# 130 HEAD CATTLE YARD

Approx Area: 261m<sup>2</sup>



**195 HEAD CATTLE YARD**  
Approx Area: 388m<sup>2</sup>

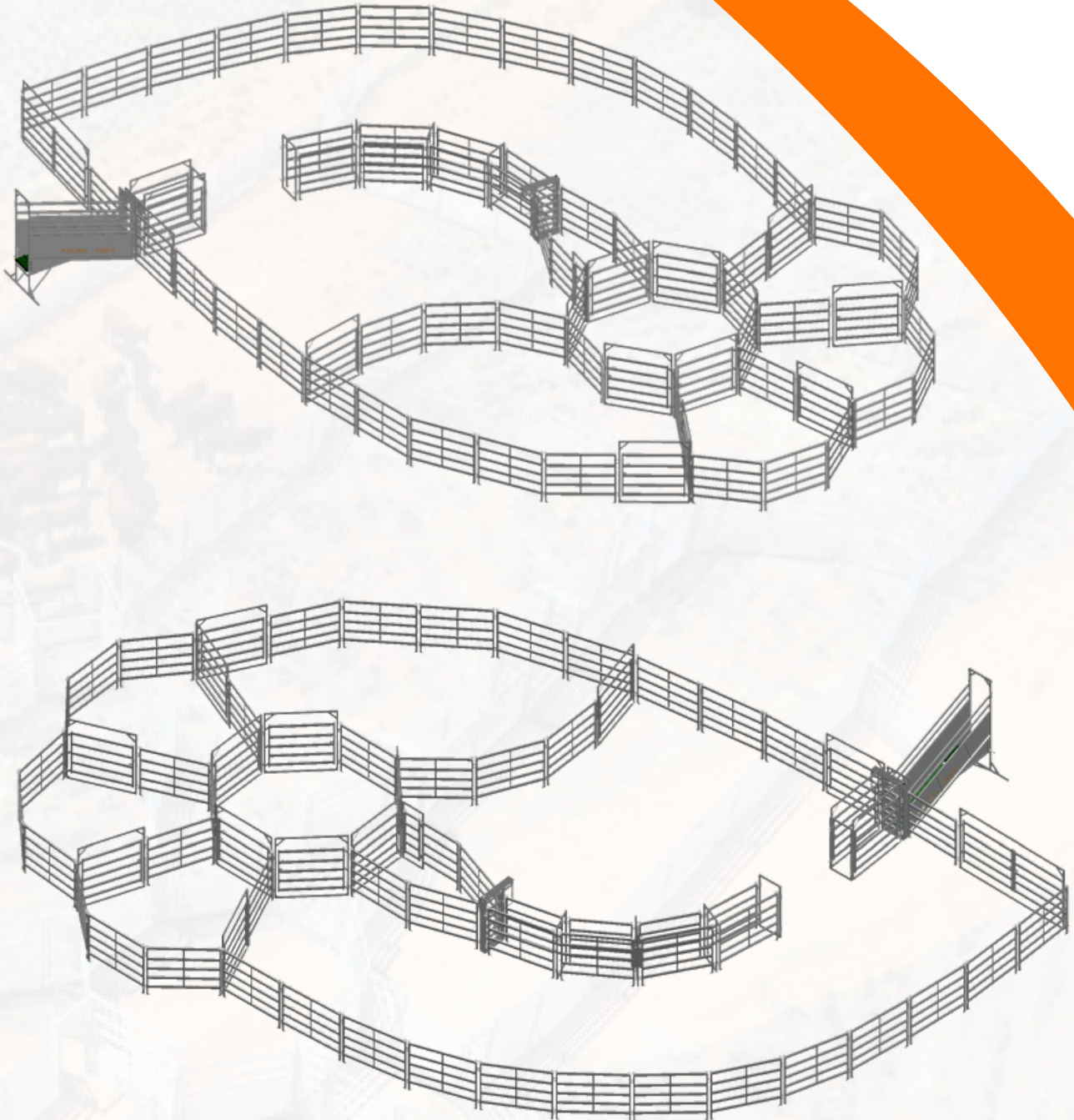

**400 HEAD CATTLE YARD**  
Approx Area: 813m<sup>2</sup>

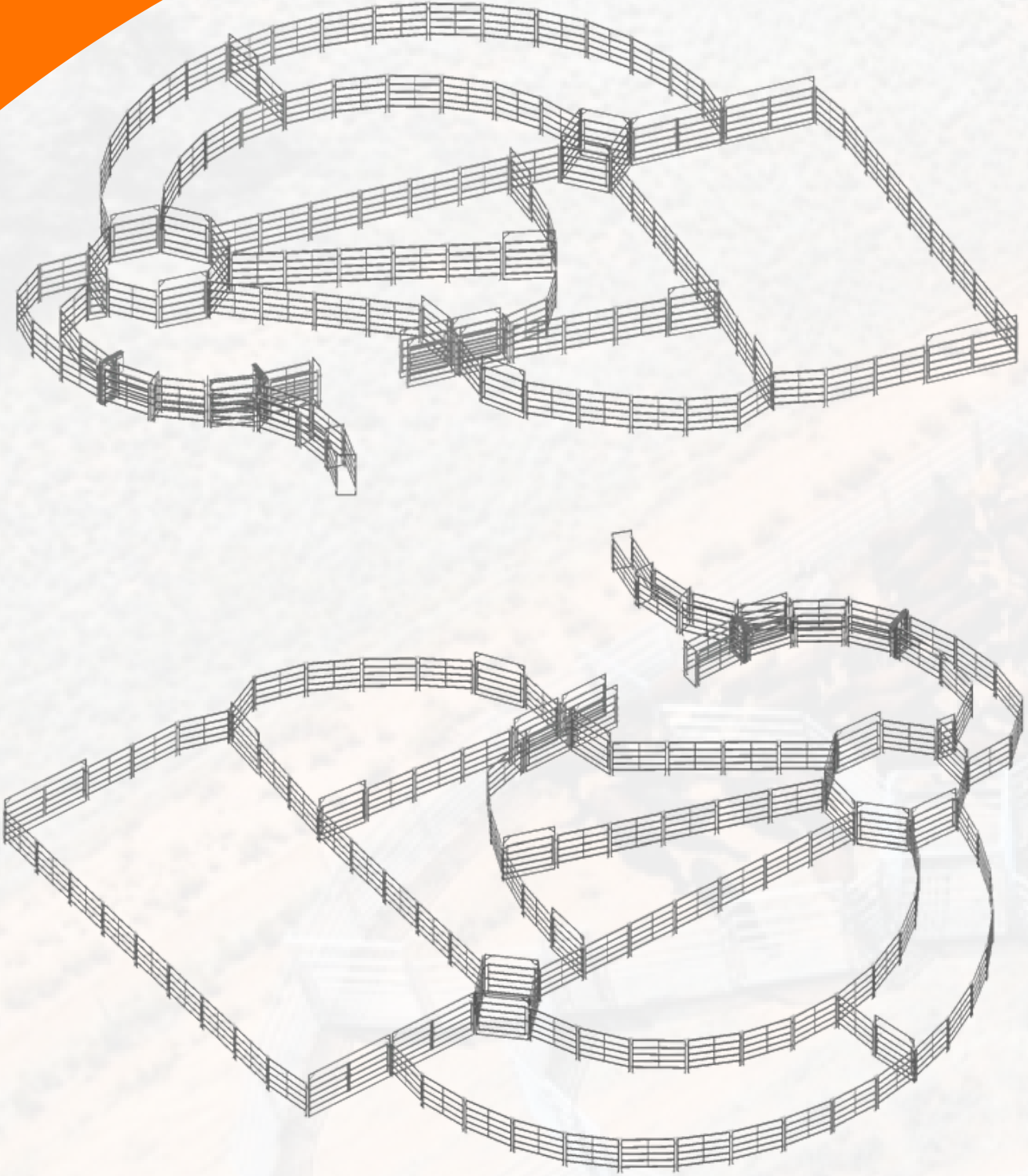



# HEAVY DUTY CATTLE PANELS

## Heavy Duty Cattle Panels

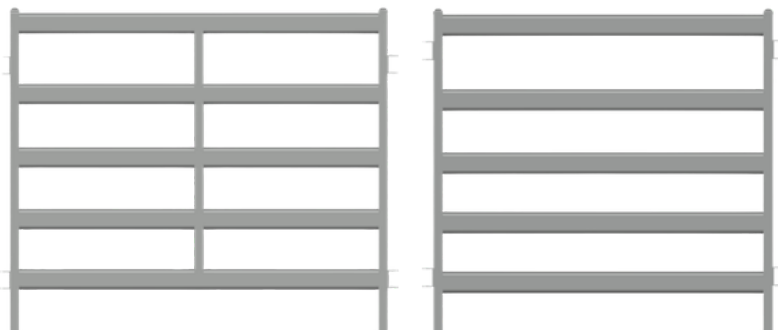

HDCP1 - 2.2m x 1.8m    HDCP2 - 1.8m x 1.7m

## Economy Cattle Panel



ECP1 - 2.2 x 1.8m

## Multi Panels

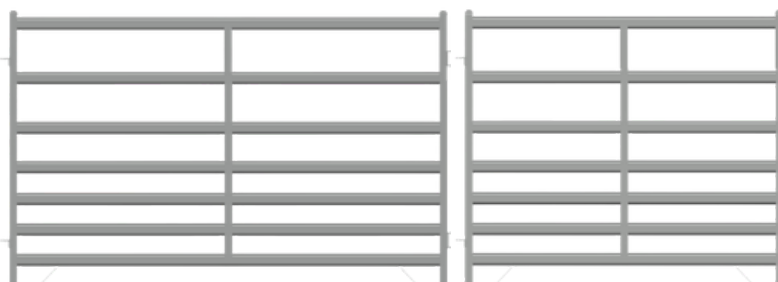

M1 - 3m x 1.8m    M2 - 2.2m x 1.8m

## Standard Cattle Panel



SCP1 - 2.2 x 1.8m

## Multi In Frame Gate

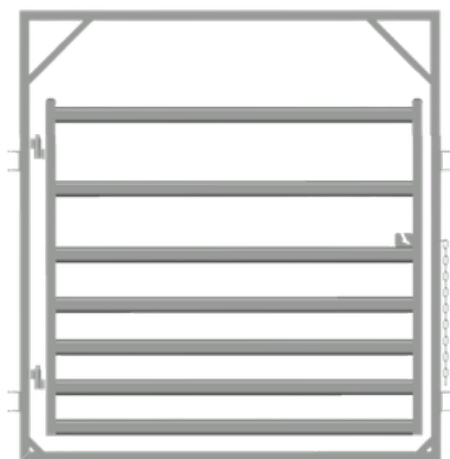

M3 - 2.2m x 1.8m

## Heavy Duty Cattle Gate

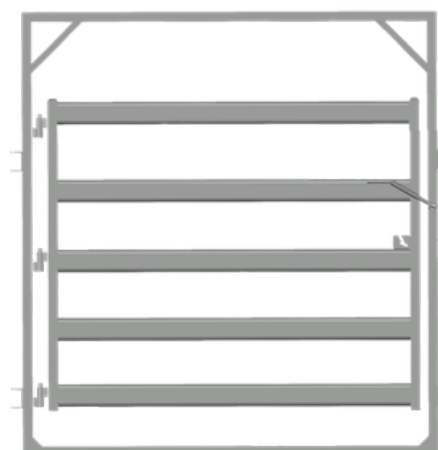

HDCG1 - 2.2m x 1.8m

## CATTLE HANDLING PRODUCTS

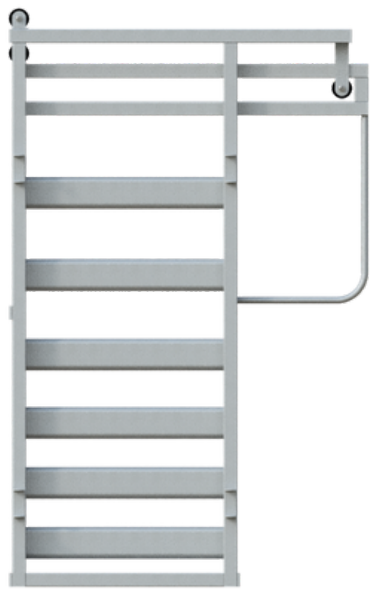

HDCSG1 - Heavy Duty Sliding Gate

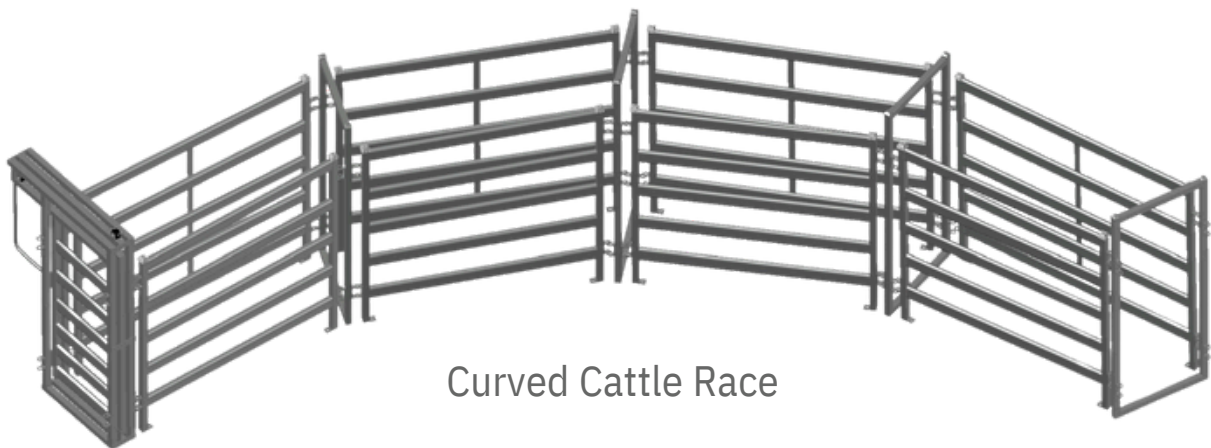
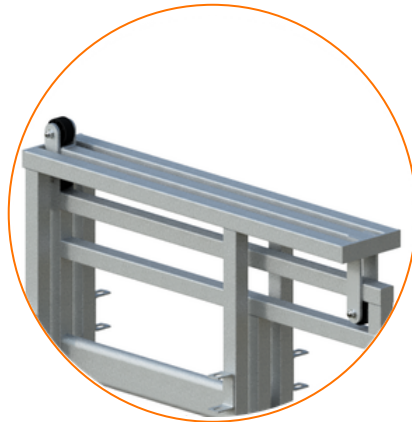

Curved Cattle Race

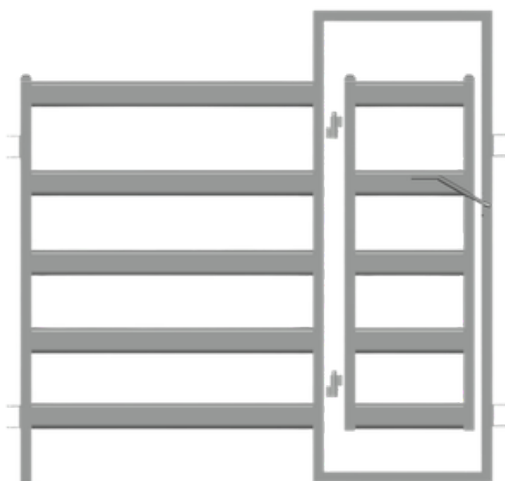

Man Gate Panel  
HDMGP1 - 2.2x1.8m





LOADING RAMPS

## HDCLR2 - Heavy-Duty Cattle Mobile Loading Ramp 3.6m

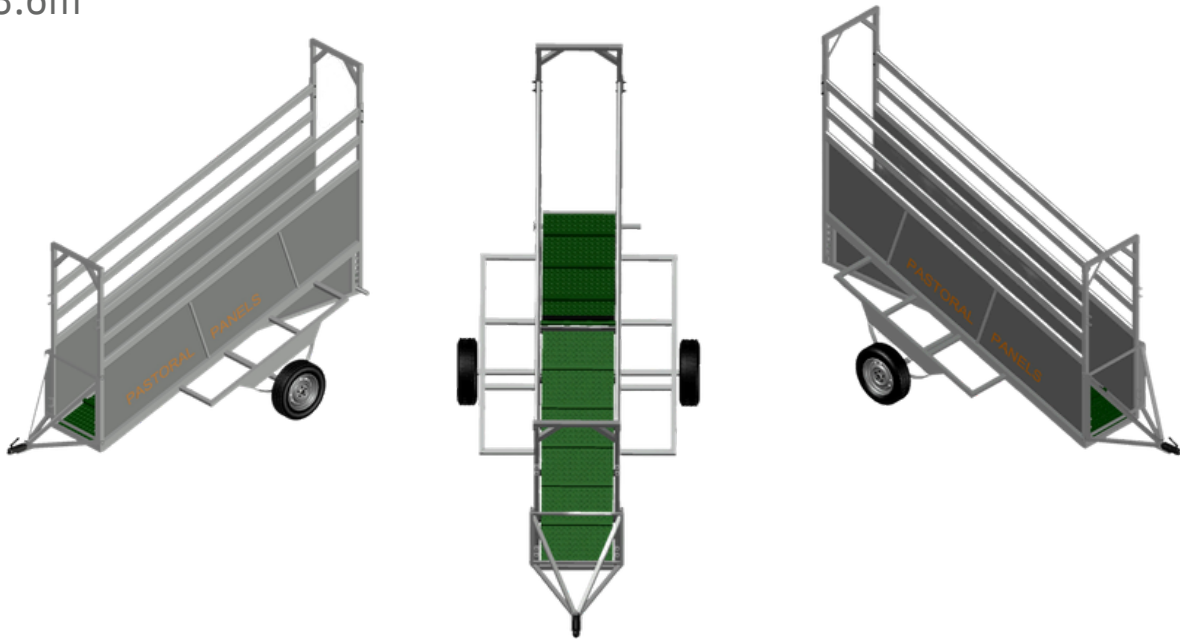

## LR2 - Mobile Goat / Sheep Loading Ramp

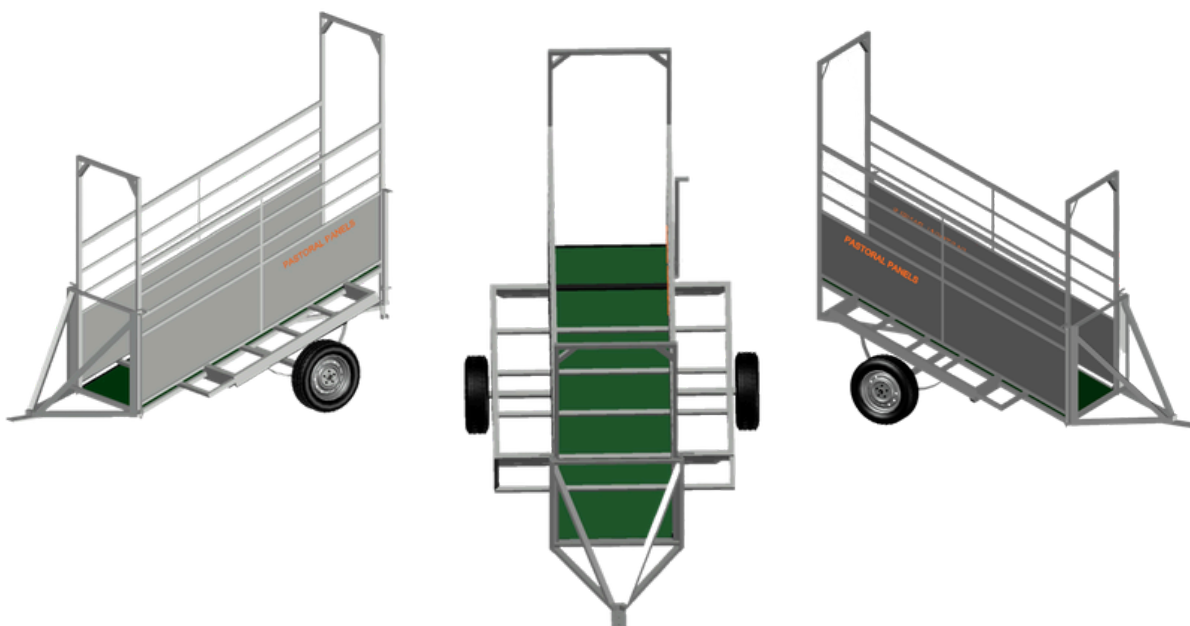

LR1 - Adjustable Goat / Sheep Loading Ramp  
3m



LR5 - Economy Goat / Sheep Loading Ramp

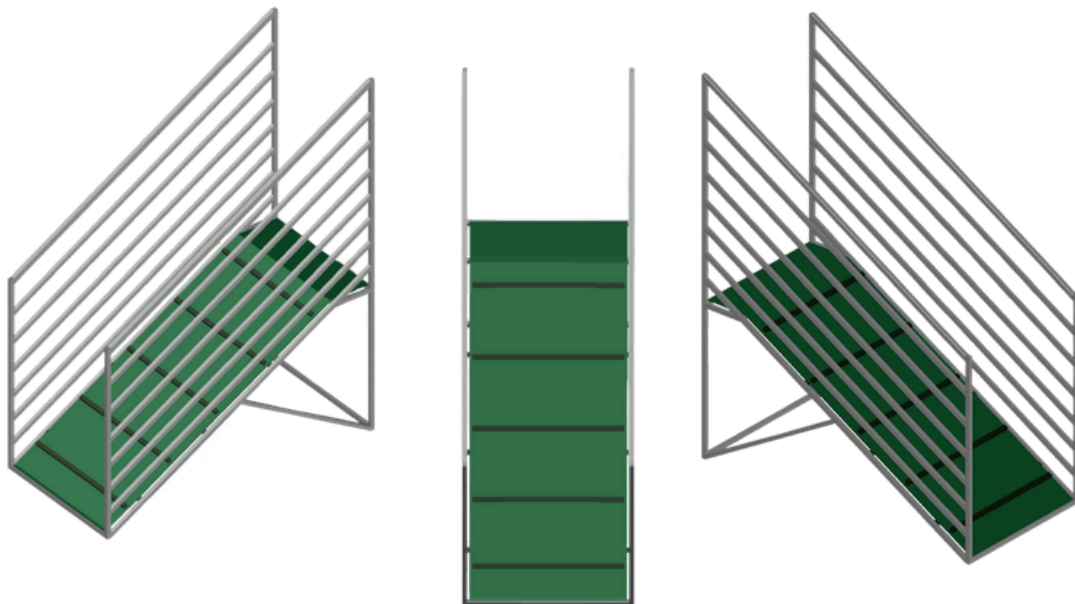

HDCLR3 - Heavy Duty Cattle Ramp  
6m

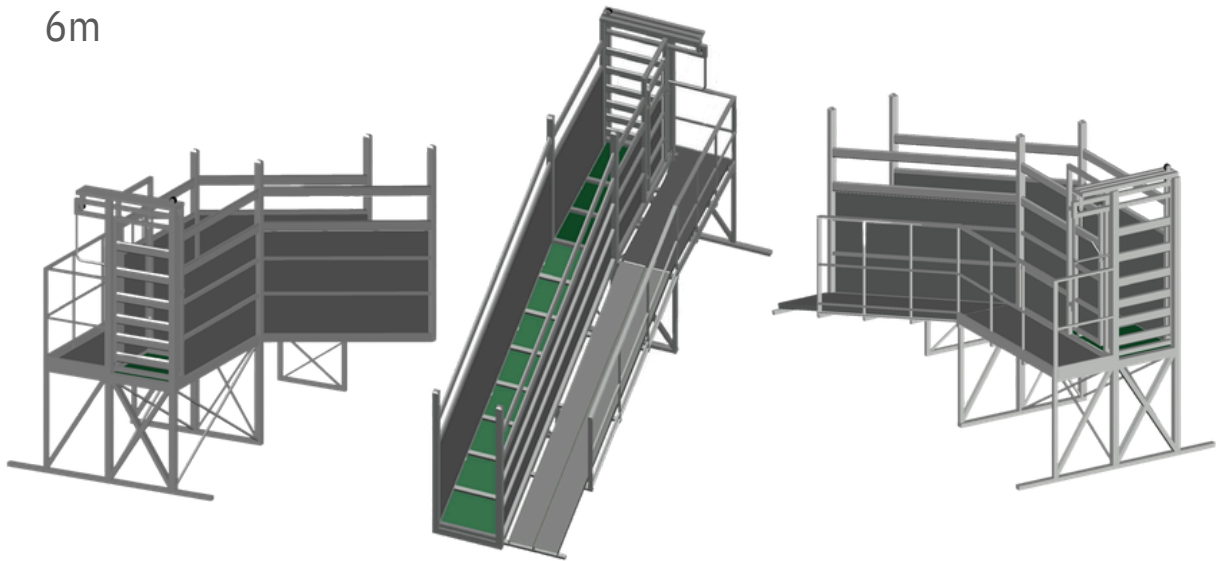

LR3 - 3 Deck Super Heavy-Duty Permanent Goat / Sheep Ramp  
8m

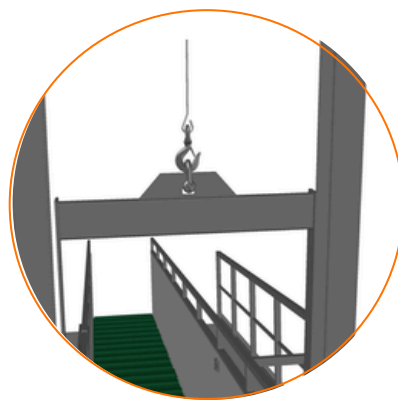
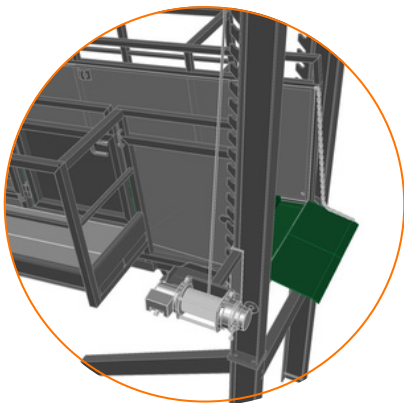
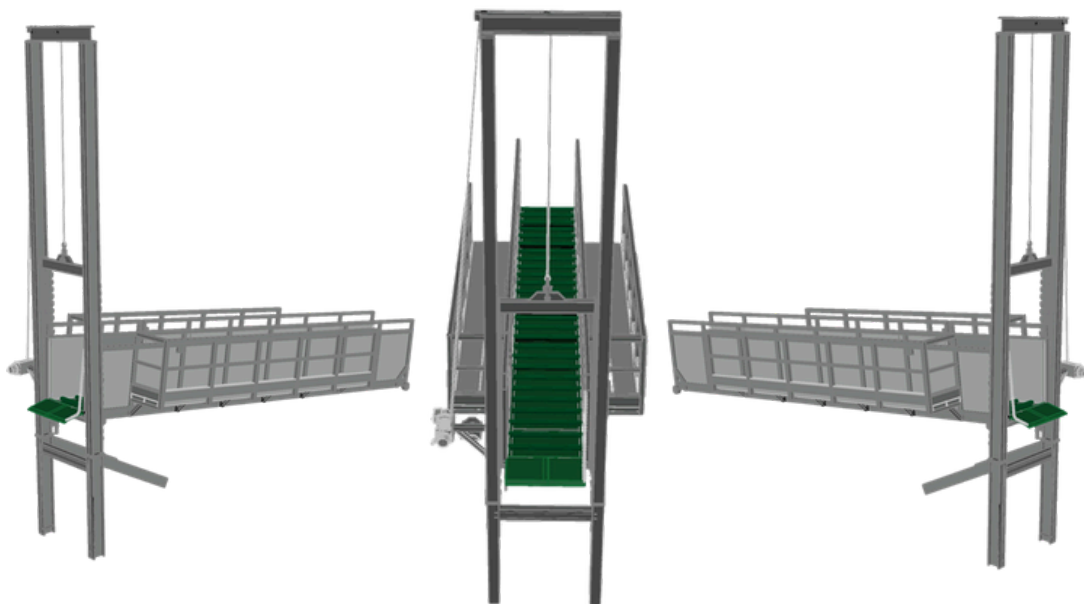



ROUND YARDS

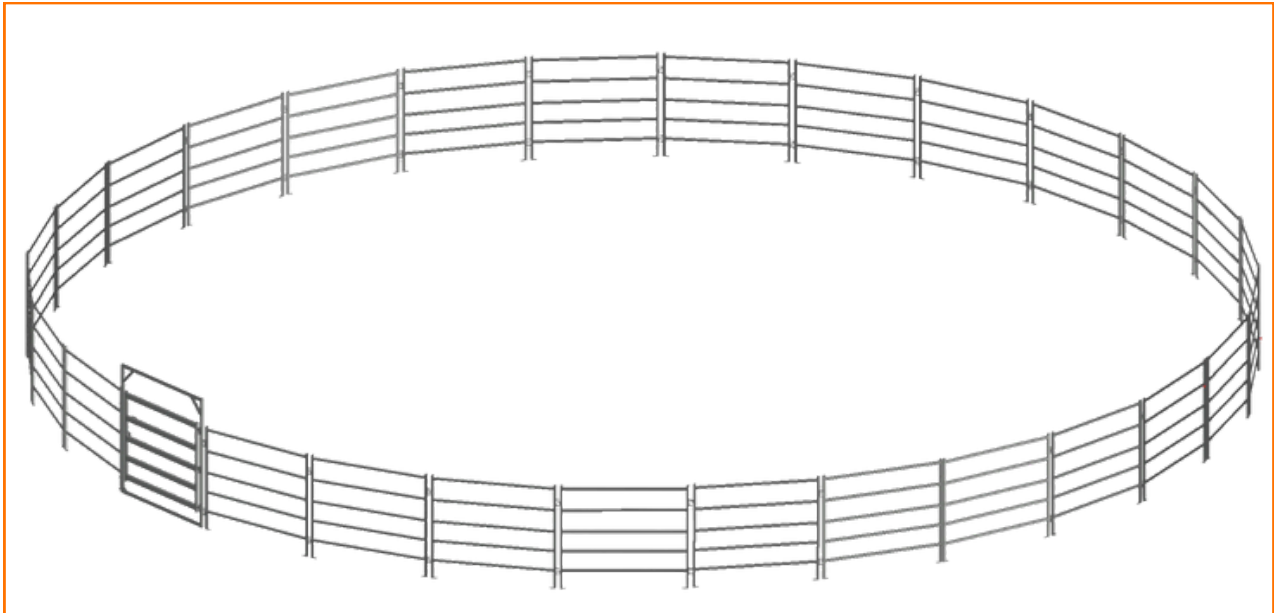

Pastoral Panels round yards are an excellent addition to any farm or equine facility. These yards are designed to be lightweight and easy to maneuver, making them an ideal solution for those who need to relocate their yard frequently.

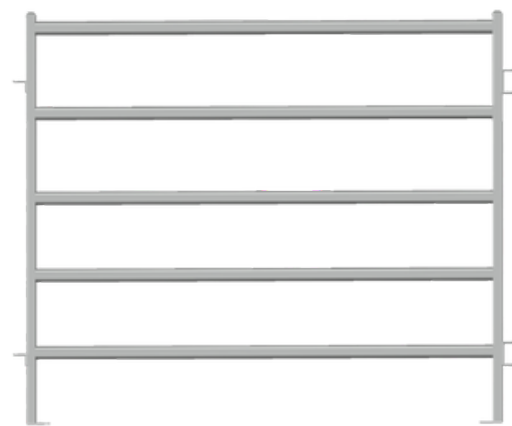

Portable Horse Panel  
H1 - 2.2x1.8m

Our panels are made from 30x60mm non bruise oval rails, with a 40x40x2mm gate frame and a removable top frame. Our round yards can be made to any size, making them an ideal choice for those who need a customised solution for their horses. Whether you have a large or small equine facility, you can be sure that these round yards will fit your needs perfectly.

These yards are quick and easy to assemble with no welding or concreting required.



## DELIVERY AND STOCKISTS

We deliver across all states and territories, bringing Pastoral Panels products straight from our depot to even the most remote properties. We know that timing is crucial, which is why we handle your order with care and efficiency, ensuring it reaches you exactly when you need it.

Our products are also available through selected rural suppliers Australia-wide.

**Contact us to discuss delivery options or locate your local stockist.**





660 Pawson Avenue, Irymple, VIC, 3498



0459 501 892



admin@pastoralpanels.com.au



www.pastoralpanels.com.au



Pastoral Panels Pty Ltd



pastoralpanels



**PASTORAL**  
*Panels*