

SAVE 90% ON LIGHTING BILL WITH THE ONLY PoE LED SYSTEM WARRANTIED ENTIRELY BY ONE MANUFACTURER



“Eco-Enterprise's manufacture has done to PoE LED lighting what Apple did to computing: One seamless technology platform where all hardware and software is made by the same company for greater savings, efficiency, reliability and security.”

PROBLEM

- **Overpaying on Electricity** - Lighting typically comprises 35% of the electricity bill; organizations are overpaying due to outdated, inefficient lighting fixtures and systems.
- **LED Burn-Out & Costly Replacements** - Companies were told to reduce costs by installing regular LED fixtures because they use less energy. Governments offered rebates to promote LED technology as a sustainable upgrade. However, a new challenge emerged: Powering LED lights via high-voltage infrastructure causes the LEDs to burn-out!



eco-enterprise

We drive sustainability for companies, nonprofits and governments while saving them money.

eco-enterprise.com / 888.444.1ECO

Available Worldwide



- **Too Many Complex Lighting Systems** - Managing various lighting systems throughout an organization can be difficult. For example, a building may have outdoor lighting, indoor lighting, scheduled lighting, motion-censored lighting, and vital emergency lighting. Many legacy systems are cumbersome to manage requiring highly-trained staff to run expensive building management software.

SOLUTION

- **Eco-Enterprise Low-Voltage PoE LED Lighting** - The future of lighting is our smart Power-over-Ethernet (PoE) LED lighting system that utilizes low-voltage via the same cabling that IT professionals use to transmit secured data (e.g: VOIP phones and Internet) and power other devices--such as LED lights.
- **One Smart Lighting System Via One Manufacture** - Eco-Enterprise's PoE LED is the only efficient, sustainable and customizable lighting system that is warrantied end-to-end because every part is designed and produced by one manufacturer.

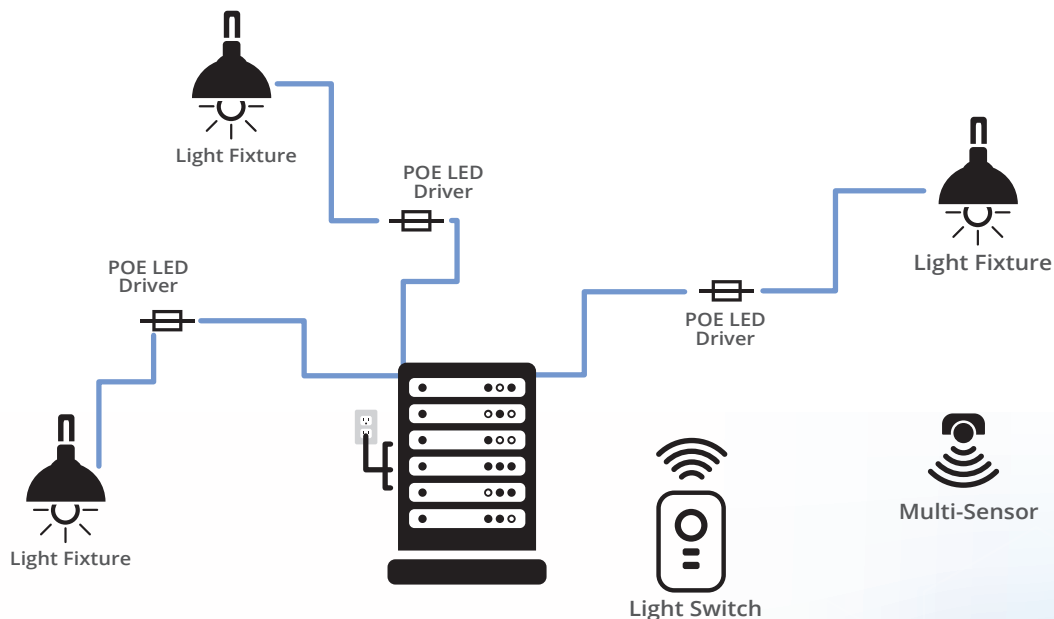

HOW DOES PoE LED WORK?

PoE is a low-voltage electricity solution that utilizes Ethernet cabling (e.g.: Cat. 5e, Cat. 6 cables and "RJ-45"-style connectors) and devices (e.g.: "switch", "driver") to connect and power LED lighting fixtures [See above diagram]. PoE is also used to power and transfer data for Voice Over Internet Protocol (VoIP) phones and Wireless Access Points (WAP).

WHY IS ECO-ENTERPRISE PoE LED LIGHTING SYSTEM THE BEST?

- **No Outages** – Other PoE LED lighting systems suffer from communications outages due to electromagnetic interference caused by over-volt current on the category cabling.
- **Guaranteed Connectivity & Reliability** – Other PoE LED lighting systems are “kits” created by using separate manufactures for a variety of components (e.g.: one company makes the lights, another company makes the switch); this piecemeal approach causes major installation and performance issues.
- **Instantaneous Illumination, Larger Coverage** – Other PoE LED lighting systems have several-second delays from the moment the light is turned "on." Eco-Enterprise PoE LED lights turn “on” immediately and transmit longer distances.
- **Competitive Pricing, Small & Large Projects** – Other PoE LED companies require an installation area of 1 million sq ft. Eco-Enterprise offers competitive manufacturer/installation pricing on all projects.
- **One System, One Warranty** – Eco-Enterprise offers the only patented end-to-end PoE LED Lighting system where all components are made by the same manufacturer and covered under one manufacturer's warranty.
- **Secure & Sustainable** – Eco-Enterprise's manufacture has done to PoE LED lighting what Apple did to computing: One seamless technology platform where all hardware and software (i.e.: control, switch, driver, fixture, power distribution supply, emergency backup battery, sensors, control software, etc.) is made by the same company. This revolutionary approach offers best-in-class:
 - Savings: “End-to-End Smart Energy System” (vs. typical “light fixture replacement”) = Best Rebates/Incentives
 - Efficiency: Fully-Customizable Control = Realtime Impact-Driven Reporting
 - Reliability: One Manufacturer/Warranty = Simple Procurement, Installation, Control and Maintenance
 - Security: Standalone System. 0% Use of Client Network = 0% Threat to Client NetworkSome companies make money fixing and repairing expensive products. Eco-Enterprise invests in manufacturers that produce high-quality products where “less maintenance” is a sustainable business model.
- **Emergency Lighting Certified** – Eco-Enterprise proudly offers the only smart PoE LED lighting system that is entirely UL924 emergency certified, “end-to-end.”
- **Financing Available** – Complete system financing is available as are significant rebates/incentives in many areas.

WHY ECO-ENTERPRISE?

We help organizations save money and drive sustainability through the following:

1. Unique Financial Solutions
2. Cutting-edge Technology
3. eco-system Smart City & Building Automation