



Proform Metals

TABLE OF CONTENTS

PAGE NUMBER:	DETAIL DESCRIPTION
A-1.....	TABLE OF CONTENTS
A-2.....	GENERAL NOTES
B-1.....	EAVE FASTENER PATTERN
B-2.....	END LAP FASTENER PATTERN
B-3 thru B-3.....	GENERAL INFORMATION
C-1.....	SIMPLE EAVE DETAIL
C-2.....	EAVE with GUTTER DETAIL
C-3.....	EAVE with SCULPTURED GUTTER DETAIL
C-4.....	FIXED RIDGE DETAIL
C-5.....	FLOATING RIDGE DETAIL
C-6.....	FIXED HIGH SIDE EAVE DETAIL
C-7.....	FLOATING HIGH SIDE EAVE DETAIL
C-8.....	FIXED HIP DETAIL
C-9.....	FLOATING HIP DETAIL
C-10.....	FIXED RAKE START DETAIL
C-11.....	FLOATING RAKE START DETAIL
C-12.....	FIXED RAKE START OFF-MODULE DETAIL
C-13.....	FLOATING RAKE START OFF-MODULE DETAIL
C-14.....	FIXED RAKE END DETAIL
C-15.....	FLOATING RAKE END DETAIL
C-16.....	FIXED RAKE END OFF-MODULE DETAIL
C-17.....	FLOATING RAKE END OFF-MODULE DETAIL
C-18.....	FIXED RAKE START TIE-IN DETAIL
C-19.....	FLOATING RAKE START TIE-IN DETAIL
C-20.....	FIXED RAKE START TIE-IN OFF-MODULE DETAIL
C-21.....	FLOATING RAKE START TIE-IN OFF-MODULE DETAIL
C-22.....	FIXED RAKE END TIE-IN DETAIL
C-23.....	FLOATING RAKE END TIE-IN DETAIL
C-24.....	FIXED RAKE TIE-IN OFF-MODULE DETAIL
C-25.....	FLOATING RAKE TIE-IN OFF-MODULE DETAIL
C-26.....	VALLEY DETAIL
C-27.....	FIXED HIGH SIDE TIE-IN DETAIL
C-28.....	FLOATING HIGH SIDE TIE-IN DETAIL
C-29 & C-30.....	END LAP DETAIL
C-31 thru 36.....	OUTSIDE CLOSURE INSTALLATION DETAIL
C-37.....	3" OUTSIDE CLOSURE INSTALLATION DETAIL
C-38.....	DEKTITE DETAIL
C-39 thru C-43.....	ALTERNATE DEKTITE DETAIL (SEAM BISECTION)
C-44 thru C-48.....	CURB INSTALLATION DETAILS
C-49 & C-50.....	TRIM LAP DETAILS

GENERAL NOTES

The details shown on the following pages are suggestions or guidelines for installing the PF Roof Panel System. The installation details shown here are proven methods of construction, but they are not intended to cover all building requirements, designs or codes. The details may require changes or revisions due to individual project conditions.

Installation procedures shall be in accordance with the manufacturer's printed instructions, details or approved shop drawings. Installers should thoroughly familiarized themselves with all instructions prior to beginning the installation process.

The designer/installer is responsible to ensure the following:

That the details here meet the particular building requirements.

Awareness of and allowance for expansion/contraction of the roof panels.

That adequate water tightness is maintained.

That a proper uniform substructure is used to avoid panel distortion and that the substructure meets necessary code requirements.

That all supporting members have been examined and are straight, level and plumb.

Proform Metals LTD can provide all flashings and accessories shown in the installation drawings unless noted otherwise. Panels, flashing and trim shall be installed true and in proper alignment with any exposed fasteners equally spaced for the best appearance. Sealant shall be field applied on a clean, dry surface.

Some field cutting and fitting of panels and flashings is to be expected and to be considered a part of normal installation work. Workmanship shall be of the best industry standards and with installation performed by experienced metal craftsmen.

Oil canning of metal panels is in the product and is not a cause for rejection. Striated panels are recommended as the reduce the appearance of oil canning.

Contents of this manual are subject to change without notice. To confirm this book is the most current copy, please visit Proform Metal LTD's website at www.proformmetalsltd.com.

EAVE FASTENER PATTERN

EAVE FASTENER PATTERN

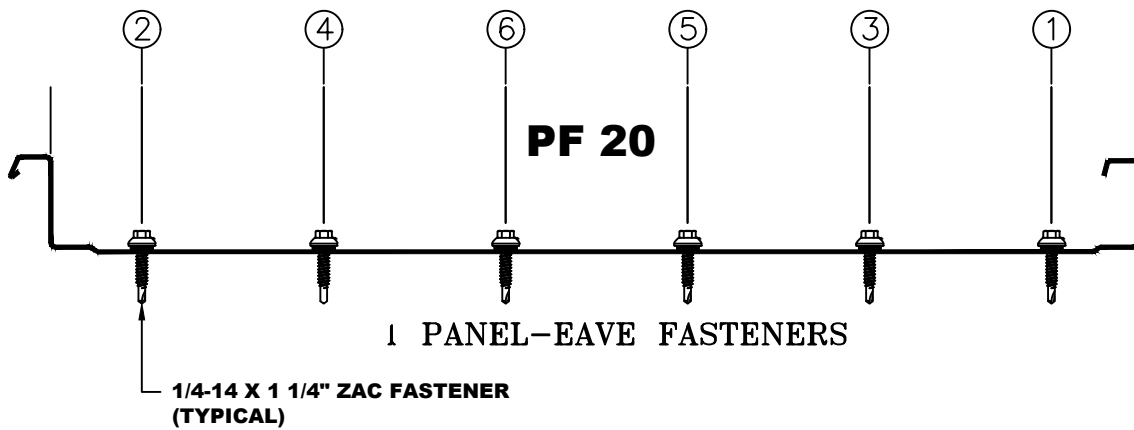
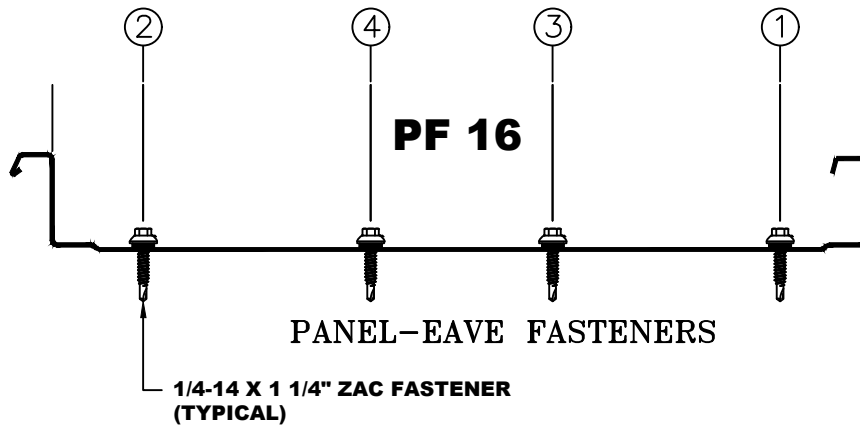
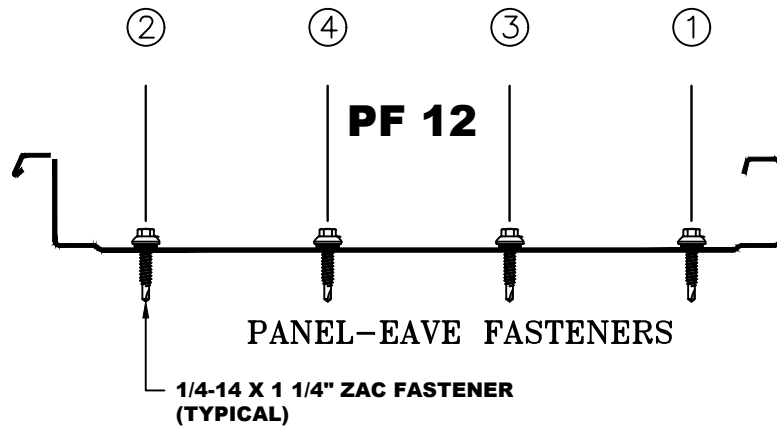

GENERAL INFORMATION

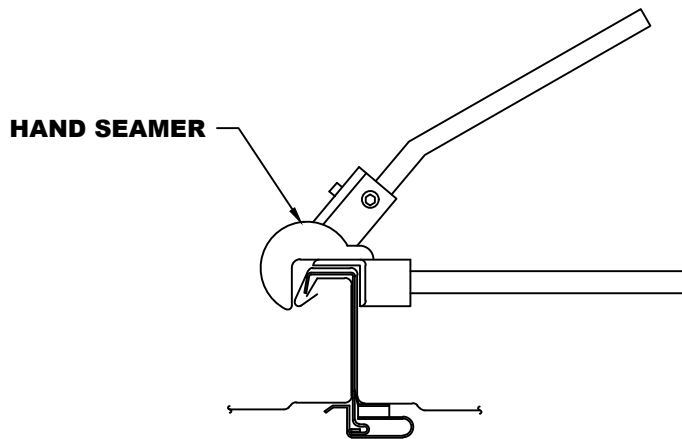

BEGINNING HAND SEAMING

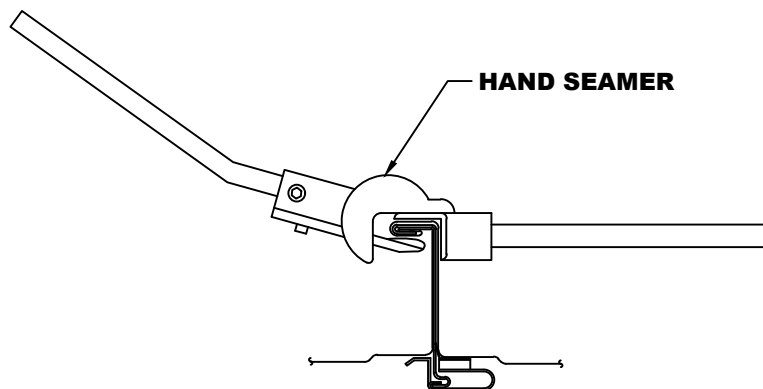

ENDING HAND SEAMING
(90° SEAM)

HAND SEAMING OPERATION

CAUTION!!!

It is critical that the panel seams are crimped and folded before using the electric seamer. Failure to follow these guidelines will result in damaged seams.

To begin seaming, set the hand seamer on the seam. Align the edge of the hand seamer about one to two inches passed the edge of the panel. Crimp the panel 3 to 4 times along the seam for a total of 12" at the eave and 5 or 6 time along the seam for a total of 18" at the ridge.

GENERAL INFORMATION

ATTENTION

READ THE SEAMER INFORMATION THOROUGHLY BEFORE STARTING THE SEAMING OPERATION. FAILURE TO ADHERE TO THESE INSTRUCTIONS MAY RESULT IN PERSONAL INJURY AND DAMAGE TO THE SEAMER AND/OR PANELS. THE ERECTOR WILL BE HELD LIABLE FOR ANY COSTS INCURRED FOR REPLACEMENT OR REPAIR.

PRE-SEAMING INFORMATION

1. Locate seamer box. Check to make sure you received a hand seamer, electric seamer and an information booklet. If not, please call our Technical Service Department.
2. Locate power source and check against power requirements in the information booklet.
3. Check seams for proper engagement.
4. Clean dirt, debris and excess sealant from seams and panel surfaces to avoid interfering with the seaming operation.
5. Panels do not have to be machine seamed as they are installed. However, PF ADV and PF 1.5" panels should be hand seamed 90° at each clip location as soon as possible.

SEAMING OPERATION

To determine the direction of the seaming process, stand at the eave and look upslope. If the roof is being installed from LEFT to RIGHT, the seamer will run from RIDGE to EAVE. If the roof is being installed from RIGHT to LEFT, the seamer will run from EAVE to RIDGE.

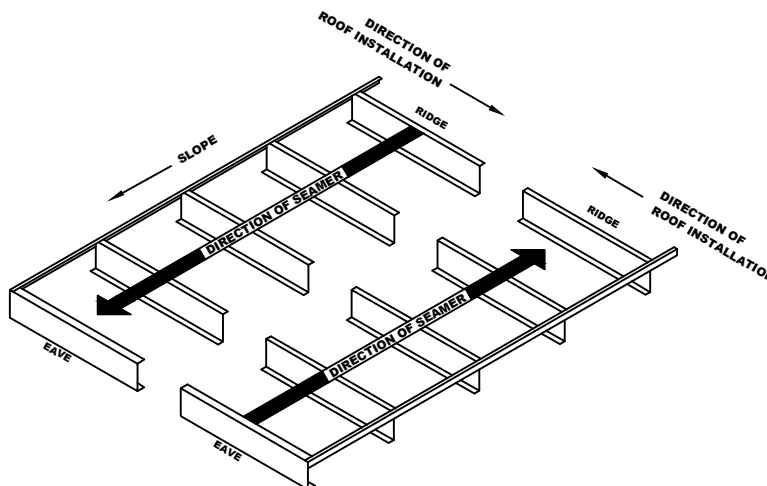

INSTALLER NOTE: IF PANELS ARE INSTALLED RIGHT TO LEFT, STANDARD OUTSIDE CLOSURES WILL NOT WORK. ZEE CLOSURE MUST BE PURCHASED AND FORM OUTSIDE CLOSURE FROM THEM. PLEASE CONTACT THE PROFORM METAL ENGINEERING DEPARTMENT IF YOU HAVE ANY QUESTIONS.

INSPECTION OF SEAM

A visual inspection of the seam should be made to determine if the seam is forming properly. Check seam against the cross section provided. IF THE SEAMER IS NOT PRODUCING A FINISHED SEAM SIMILAR TO THE CROSS SECTION PICTURED, STOP AT ONCE AND CALL THE PROFORM METAL TECHNICAL SERVICE DEPARTMENT.

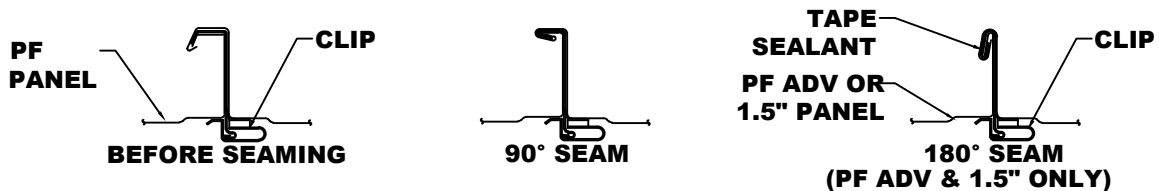

CROSS SECTION OF SEAM

CAUTION: The use of any field seaming machine other than that provided by the manufacturer may damage the panels, void all warranties and will void all engineering data.

PF EAVE DETAIL W/ SIMPLE EAV TRIM

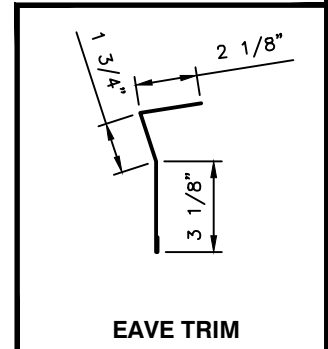
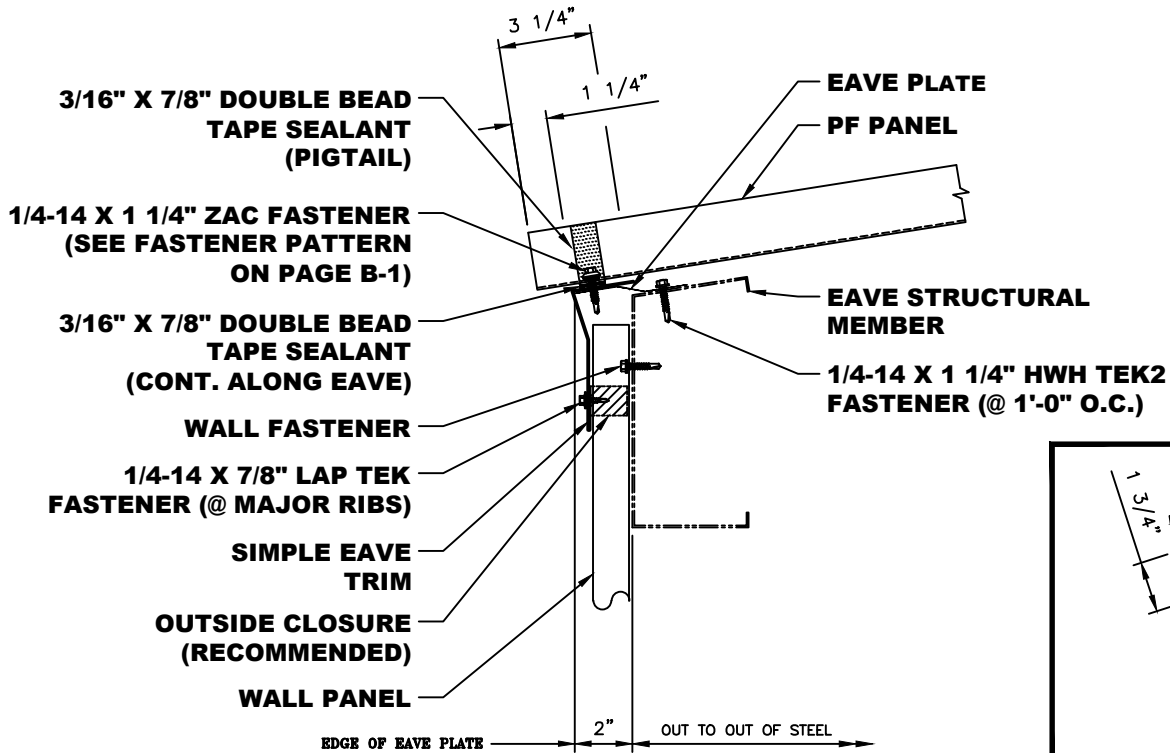

- NOTES:**
1. Eave Plate to run from steel line to steel line.
 2. Simple Eave Trim to run from out of wall to out of wall.
 3. Attach Simple Eave Trim to Eave Plate with temporary fasteners. Attach to wall panel at major ribs with 1/4-14 x 7/8" Lap Tek fasteners.
 4. Trim pieces lap 2". Apply 3/32" x 3/8" Butyl Tape or Butyl Tube Sealant in trim laps and Pop Rivet trims as shown on page C-36.
 5. Apply continuous run of 3/16" x 7/8" Double Bead Tape on top of Simple Eave Trim.
 6. Apply 3/16" x 7/8" Double Bead Tape Pigtails at Eave.

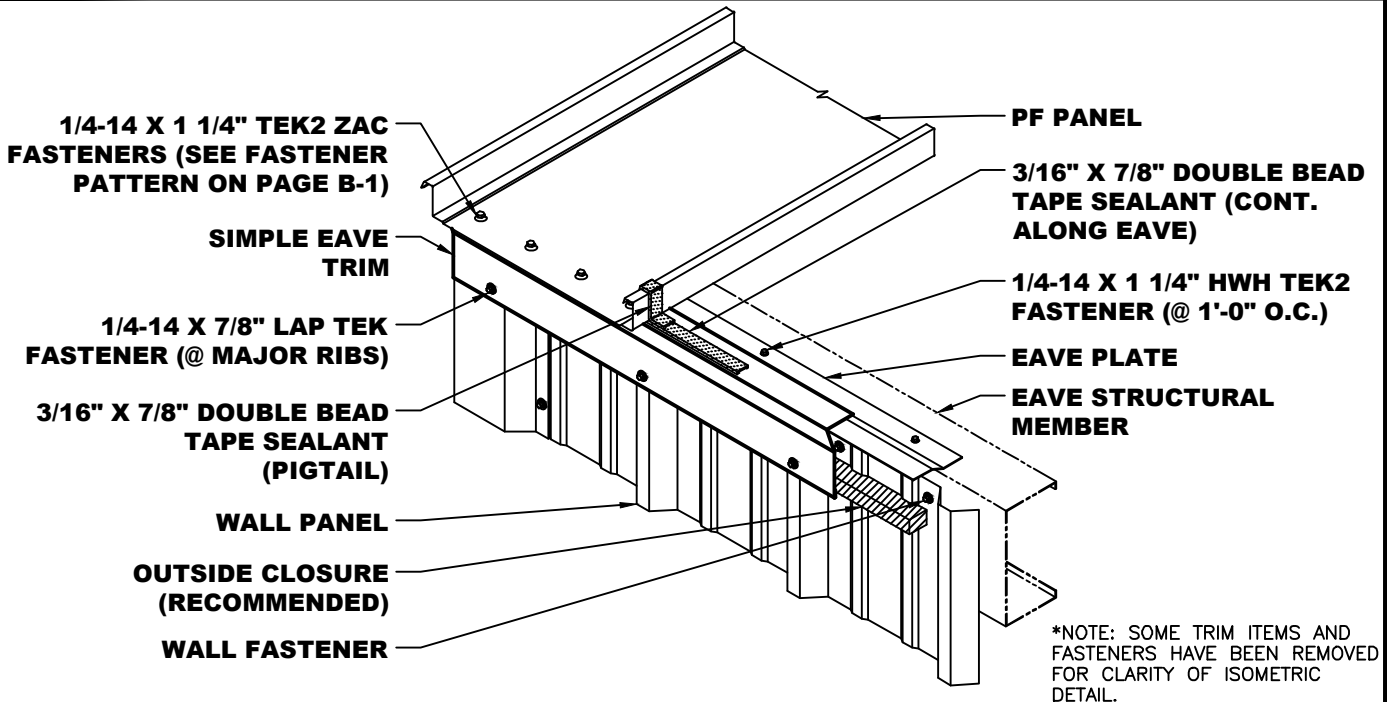

PF EAVE W/ GUTTER DETAIL

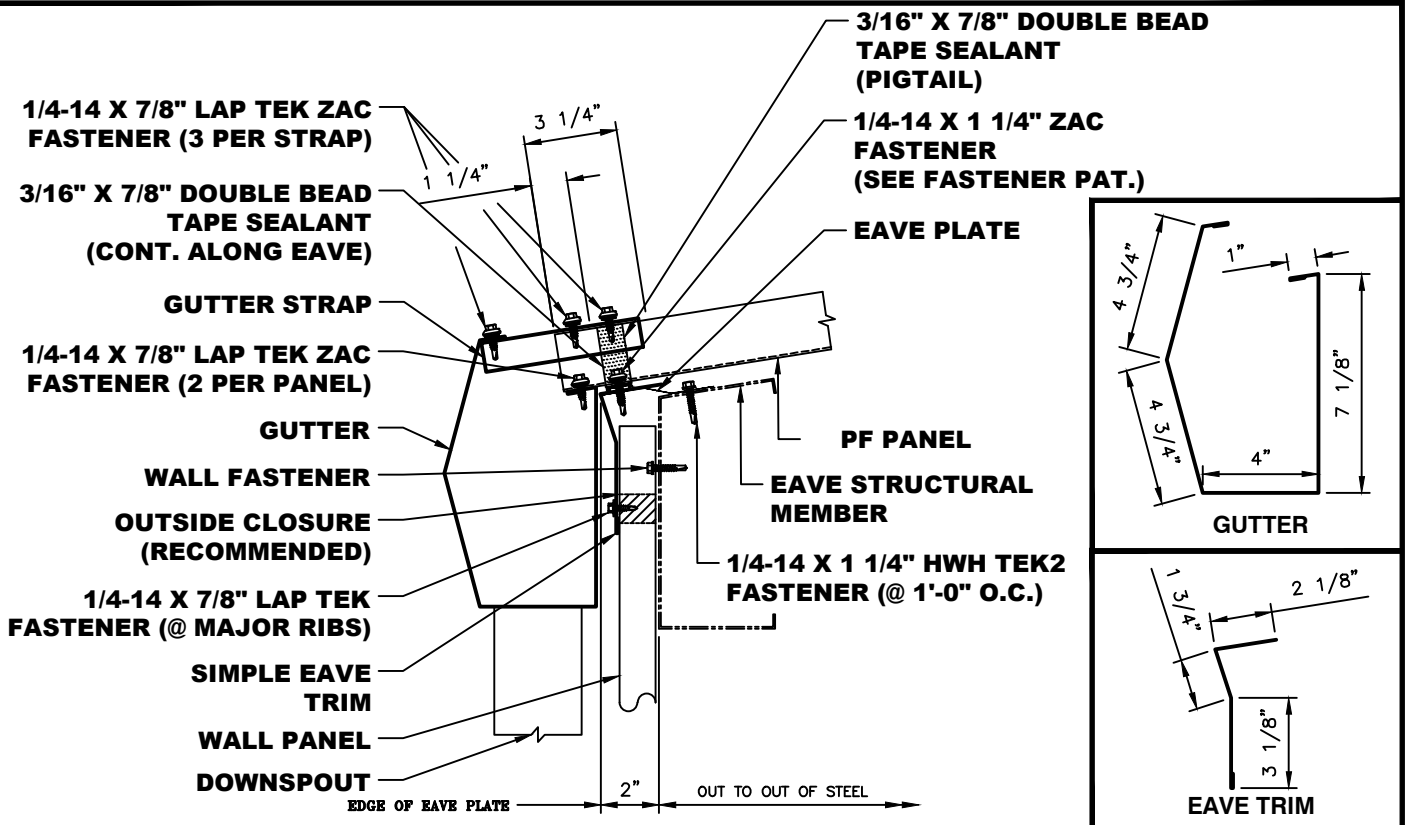

- NOTES:**
1. Eave Plate to run from steel line to steel line.
 2. Simple Eave Trim and Gutter to run from out of wall to out of wall.
 3. Attach Simple Eave Trim to Eave Plate with temporary fasteners. Attach to wall panel at major ribs with a 1/4-14 x 7/8" Lap Tek.
 4. Trim pieces lap 2". Apply 3/32" x 3/8" Butyl Tape or Butyl Tube Sealant at trim laps and Pop Rivet trims as shown on page C-36.
 5. Apply continuous run of 3/16" x 7/8" Double Bead on top of Simple Eave Trim.
 6. Apply 3/16" x 7/8" Double Bead Pigtails at Eave.
 7. Attach Gutter to roof panel with 1/4-14 x 7/8" Lap Tek ZAC fasteners at 1'-0" O.C. Attach Gutter Straps to panel ribs with 1/4-14 x 7/8" Lap Tek ZAC fastener. Then attach Gutter to Gutter Strap with a 1/4-14 x 7/8" Lap Tek ZAC fasteners.

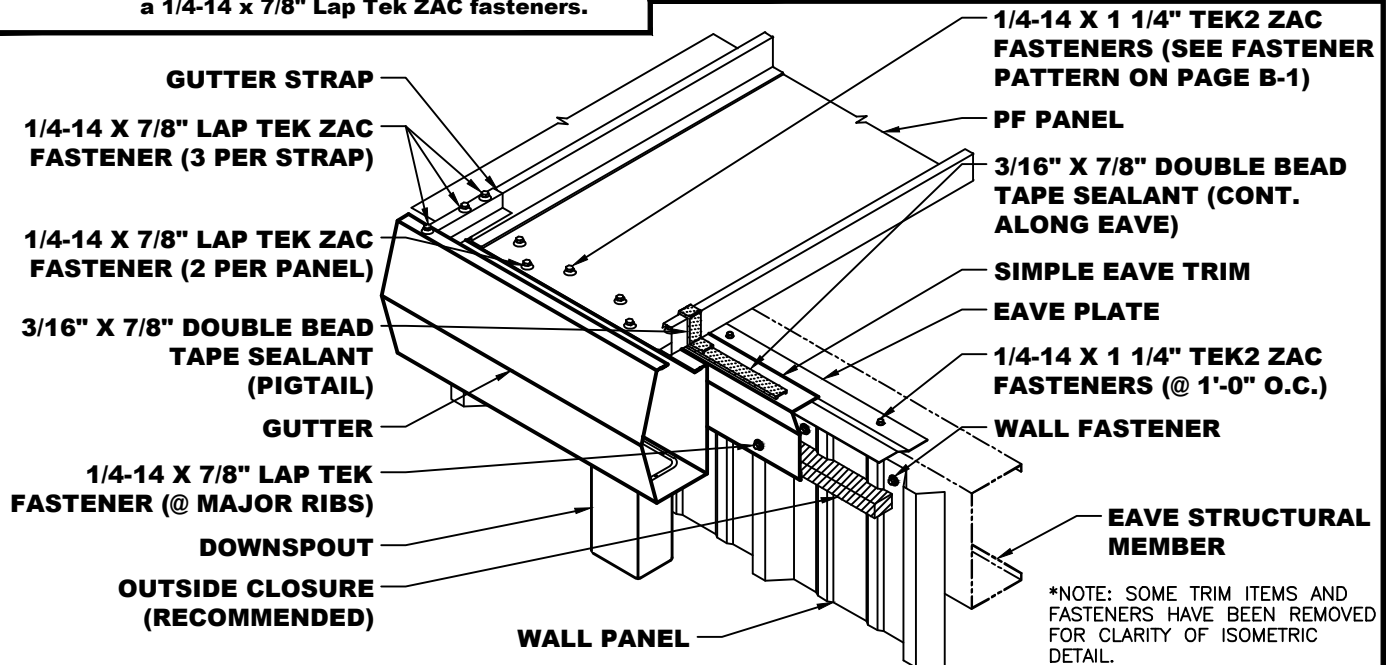

PF EAVE DETAIL W/ SCULPTURED EAVE TRIM

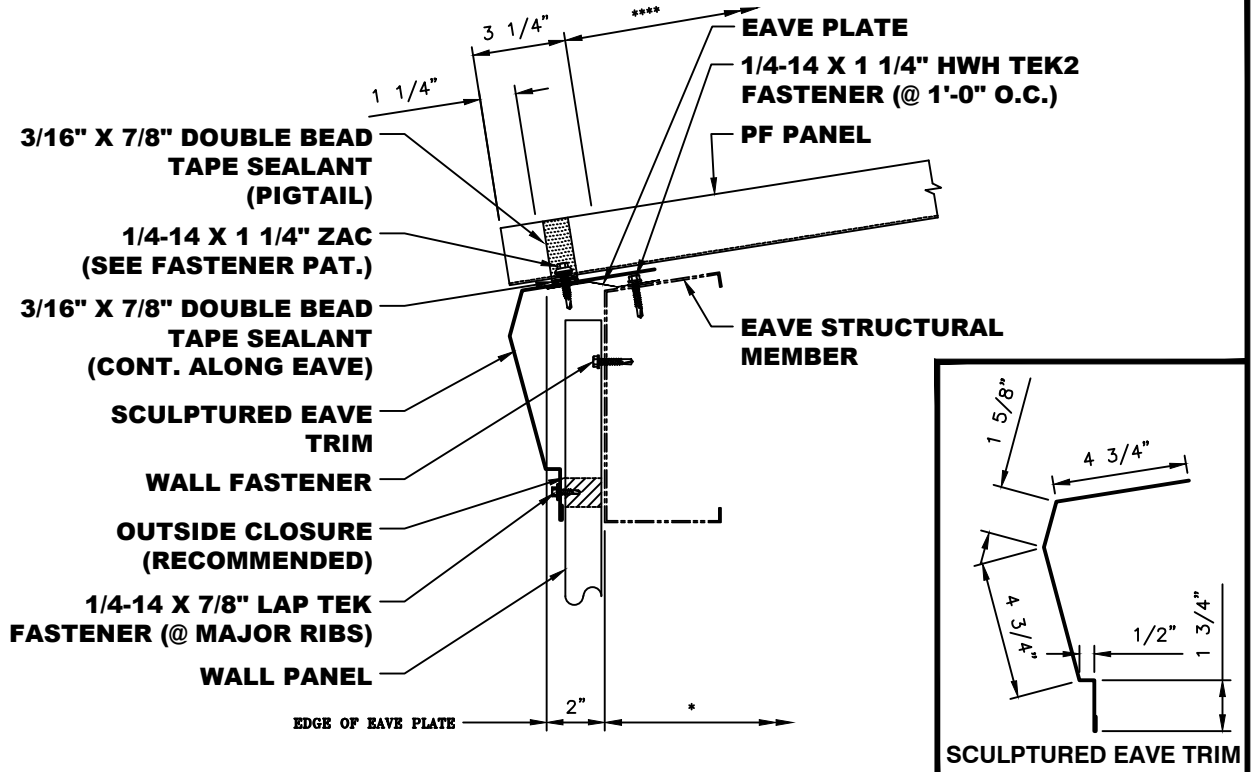

- NOTES:**
1. Eave Plate to run from steel line to steel line.
 2. Sculptured Eave Trim to run from out of wall to out of wall.
 3. Attach Sculptured Eave Trim to Eave Plate with temporary fasteners. Attach to wall panel at major ribs with a 1/4-14 x 7/8" Lap Tek.
 4. Apply continuous run of 3/16" x 7/8" Double Bead on top of Sculptured Eave Trim.
 5. Apply 3/16" x 7/8" Double Bead Pigtailed at Eave and Ridge of male panel leg as shown on page ____.
 6. Trim pieces lap 2". Apply 3/32" x 3/8" Butyl Tape or Butyl Tube Sealant at trim laps and Pop Rivet trims as shown on page C-36.

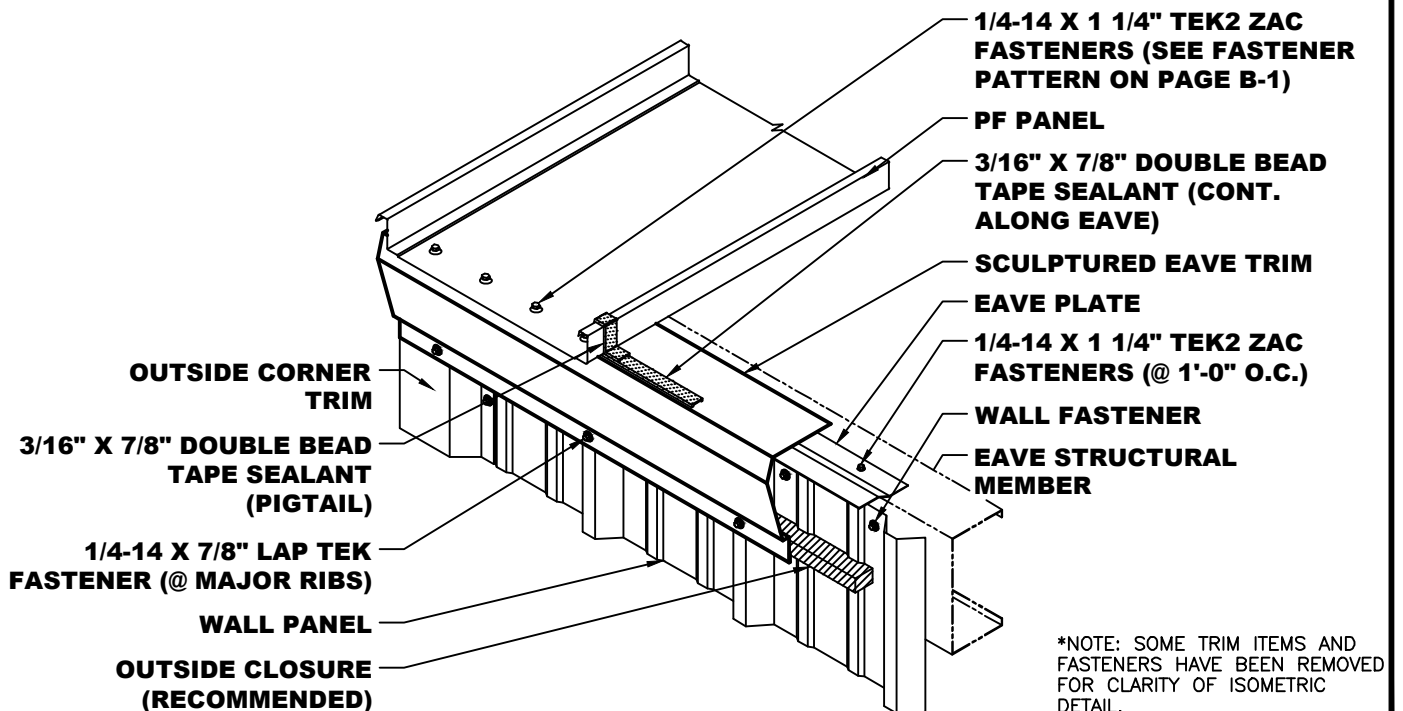

PF FIXED RIDGE DETAIL

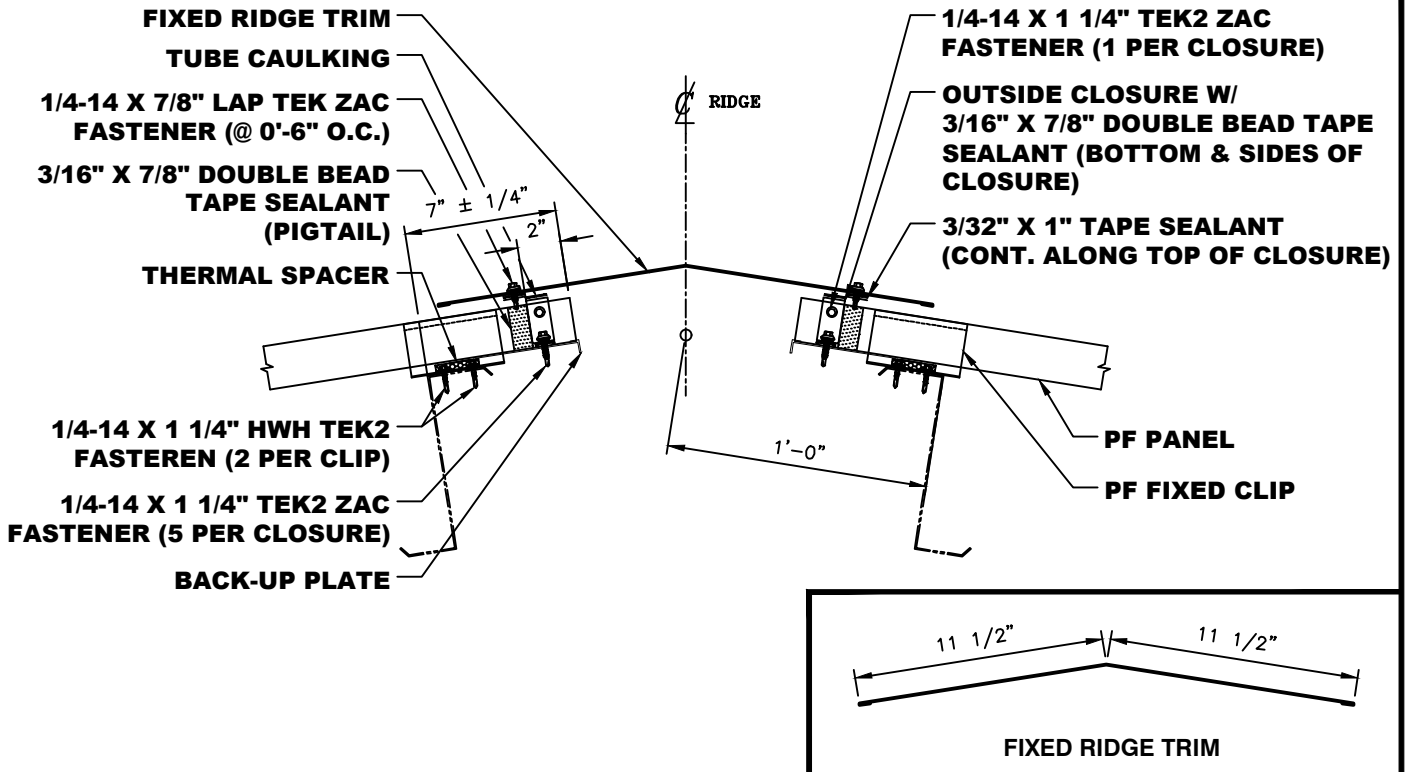

- NOTES:**
1. Ridge Flashing to 2" outside of face of wall panels.
 2. Place 3/32" x 1" Roll Tape Sealant on top flange of Outside Closures continuously along Ridge.
 3. Attach Ridge Flashing to Outside Closures with 1/4-14 x 7/8" Lap Tek ZAC fasteners at 6" O.C.
 4. Trim pieces lap 2". Apply 3/32" x 3/8" Butyl Tape or Butyl Tube Sealant at trim laps and secure trim joint with 1/4-14 x 7/8" Lap Tek Zac Fasteners at 3" O.C.
 5. For Low Systems only, the first as well as the last Back-up Plate must be field modified to properly nest with the Rake Angle. Notch out the vertical leg of Back-up Plate to clear Rake Angle.

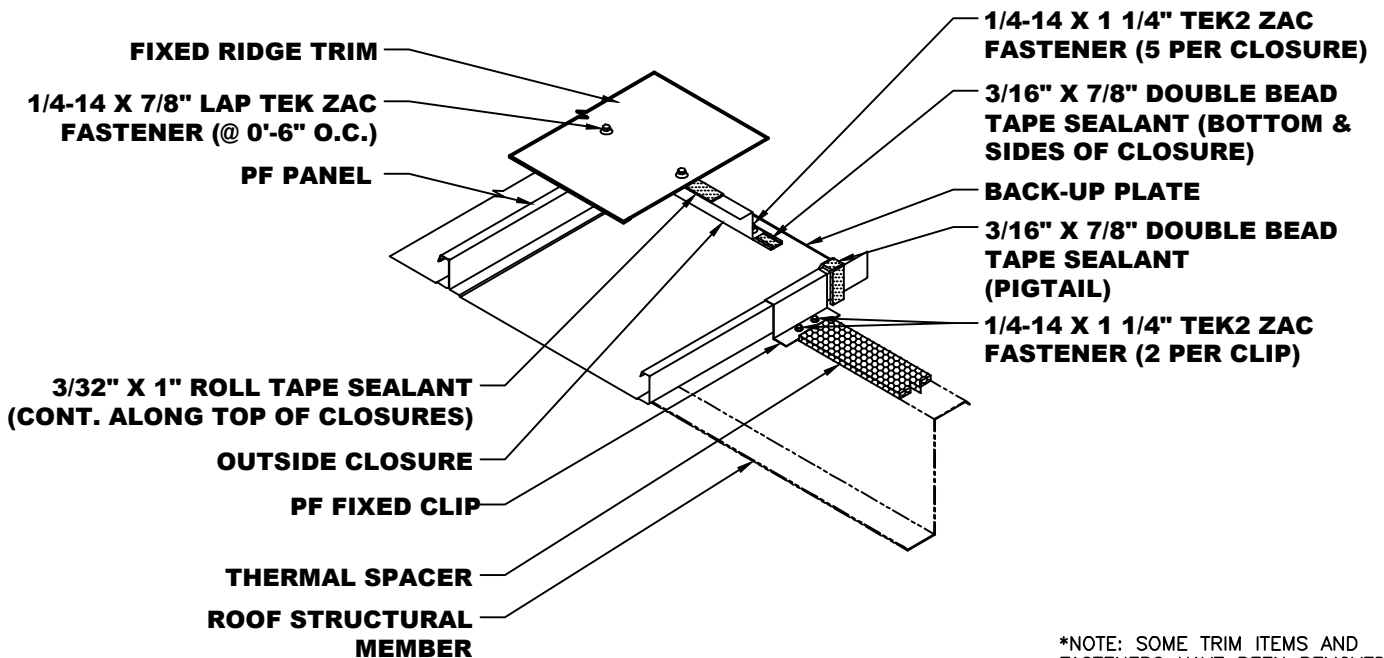

*NOTE: SOME TRIM ITEMS AND FASTENERS HAVE BEEN REMOVED FOR CLARITY OF ISOMETRIC DETAIL.

PF FLOATING RIDGE DETAIL

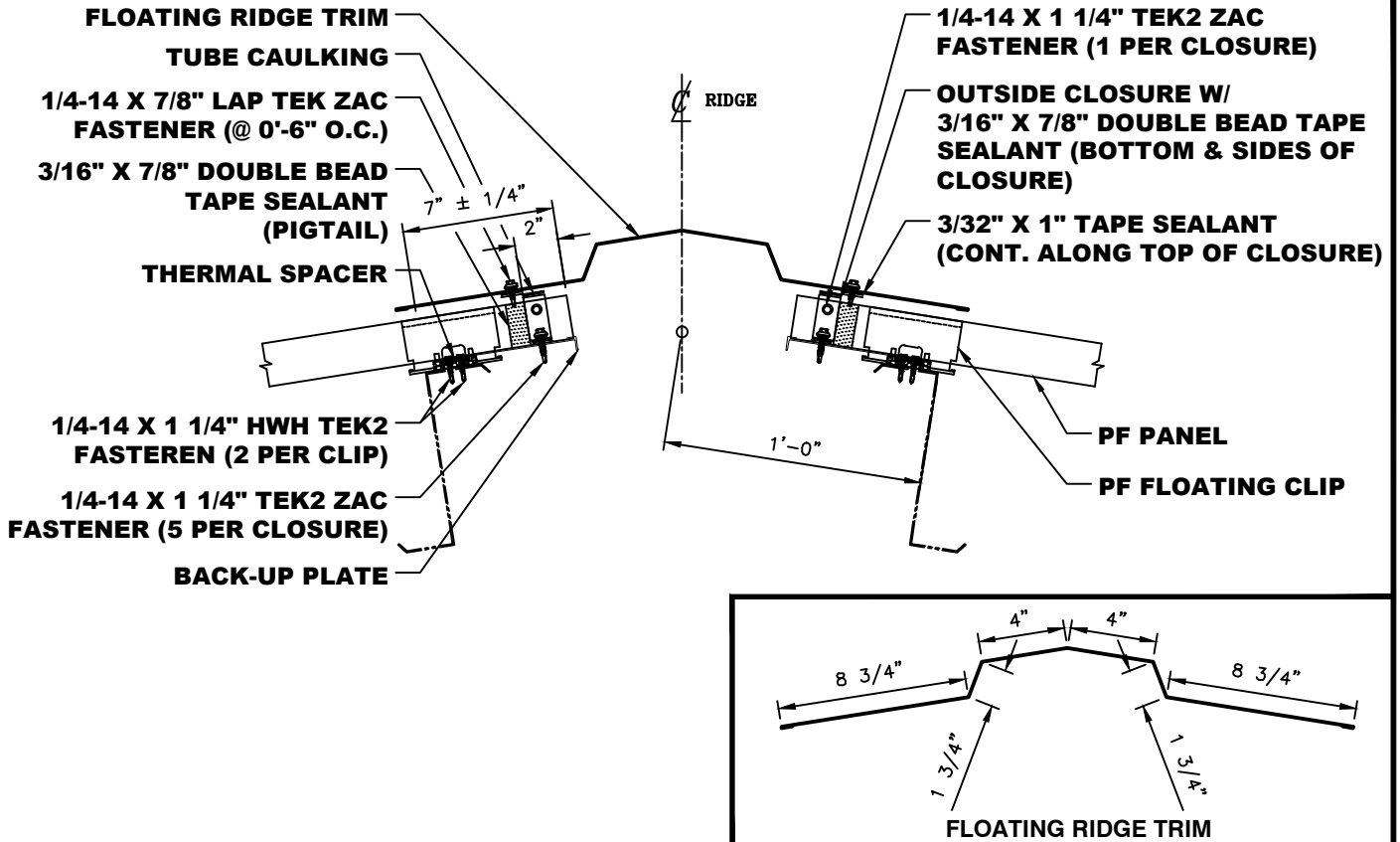

- NOTES:**
1. Ridge Flashing to 2" outside of face of wall panels.
 2. Place 3/32" x 1" Roll Tape Sealant on top flange of Outside Closures continuously along Ridge.
 3. Attach Ridge Flashing to Outside Closures with 1/4-14 x 7/8" Lap Tek ZAC fasteners at 6" O.C.
 4. Trim pieces lap 2". Apply 3/32" x 3/8" Butyl Tape or Butyl Tube Sealant at trim laps and secure trim joint with 1/4-14 x 7/8" Lap Tek Zac Fasteners at 3" O.C.

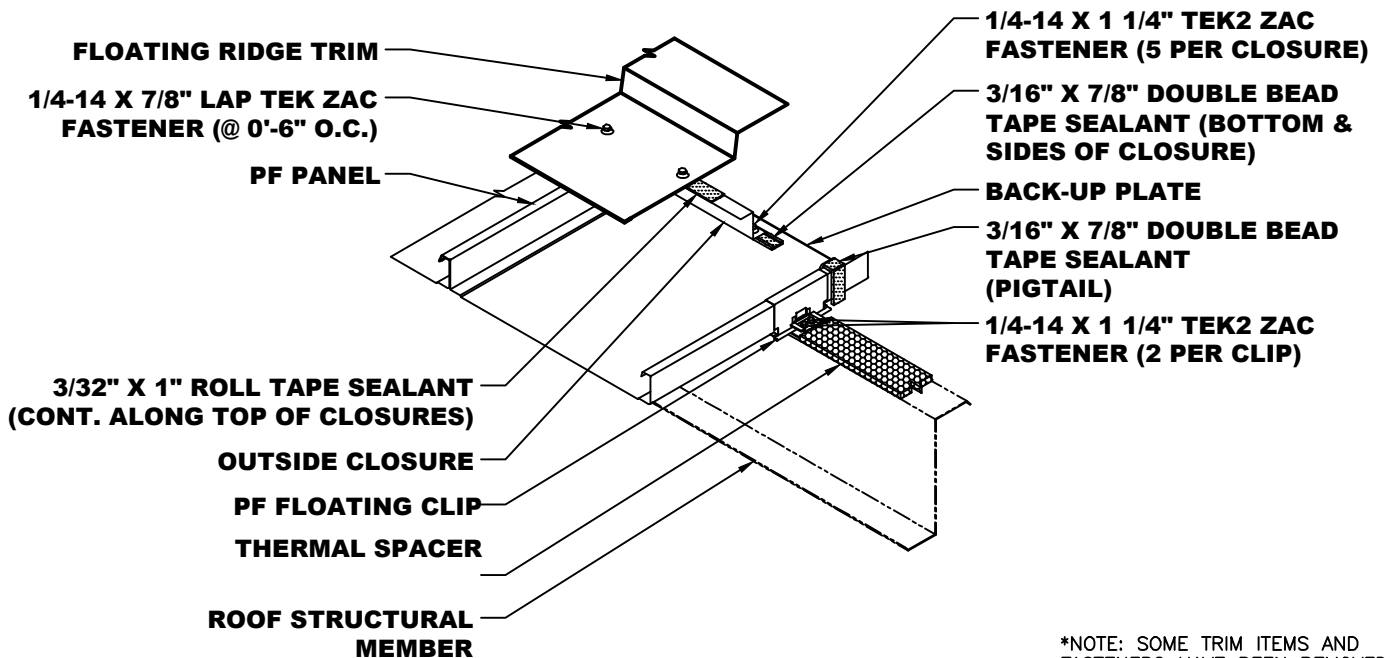

*NOTE: SOME TRIM ITEMS AND FASTENERS HAVE BEEN REMOVED FOR CLARITY OF ISOMETRIC DETAIL.

PF FIXED HIGH SIDE EAVE DETAIL

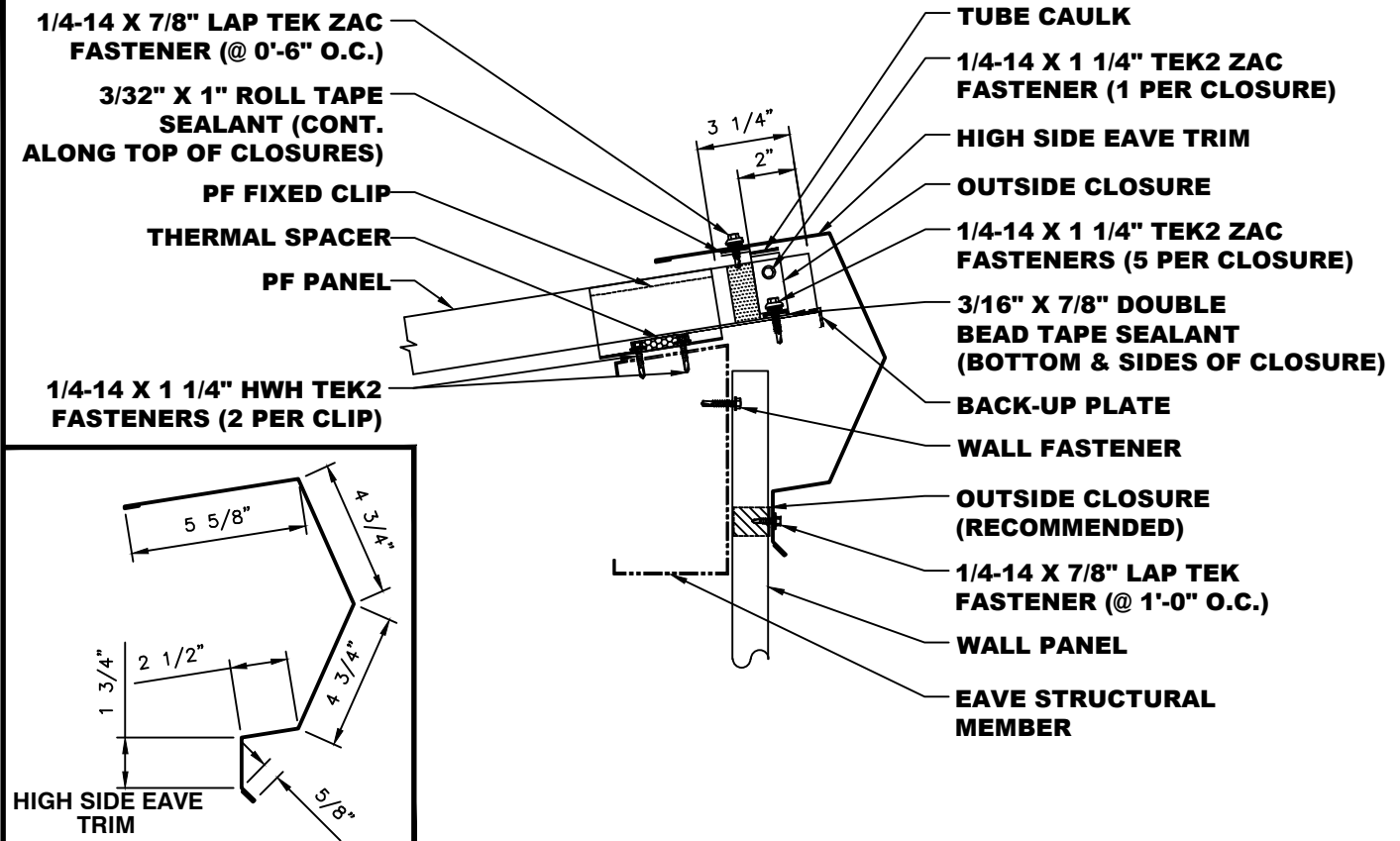

- NOTES:**
1. High Side Eave Flashing to run from out of wall to out of wall.
 2. Place 3/32" x 1" Roll Tape Sealant on top flange of Outside Closures continuously along Ridge.
 3. Attach High Side Eave Flashing to Outside Closures with 1/4-14 x 7/8" Lap Tek ZAC fasteners at 6" O.C.
 4. Trim pieces lap 2". Apply 3/32" x 3/8" Butyl Tape or Butyl Tube Sealant at trim laps and secure trim joint with Pop Rivets as shown on page C-36.

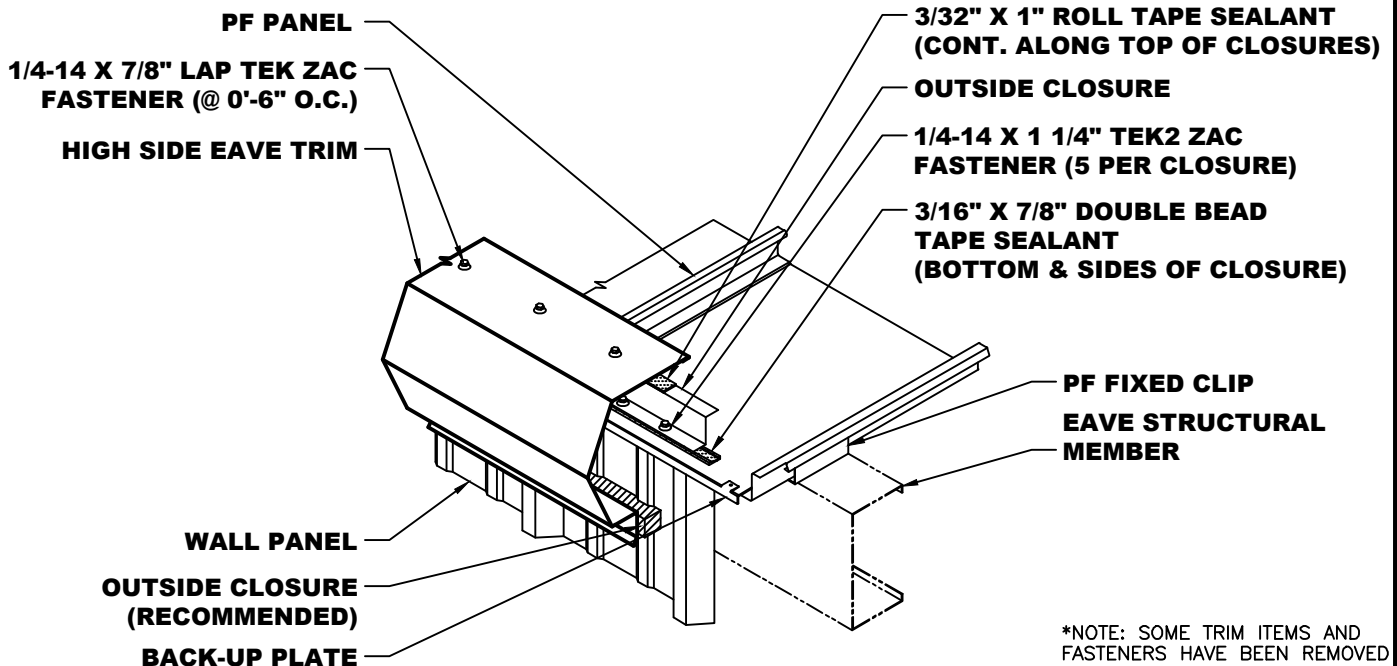

*NOTE: SOME TRIM ITEMS AND FASTENERS HAVE BEEN REMOVED FOR CLARITY OF ISOMETRIC DETAIL.

PF FLOATING HIGH SIDE EAVE DETAIL

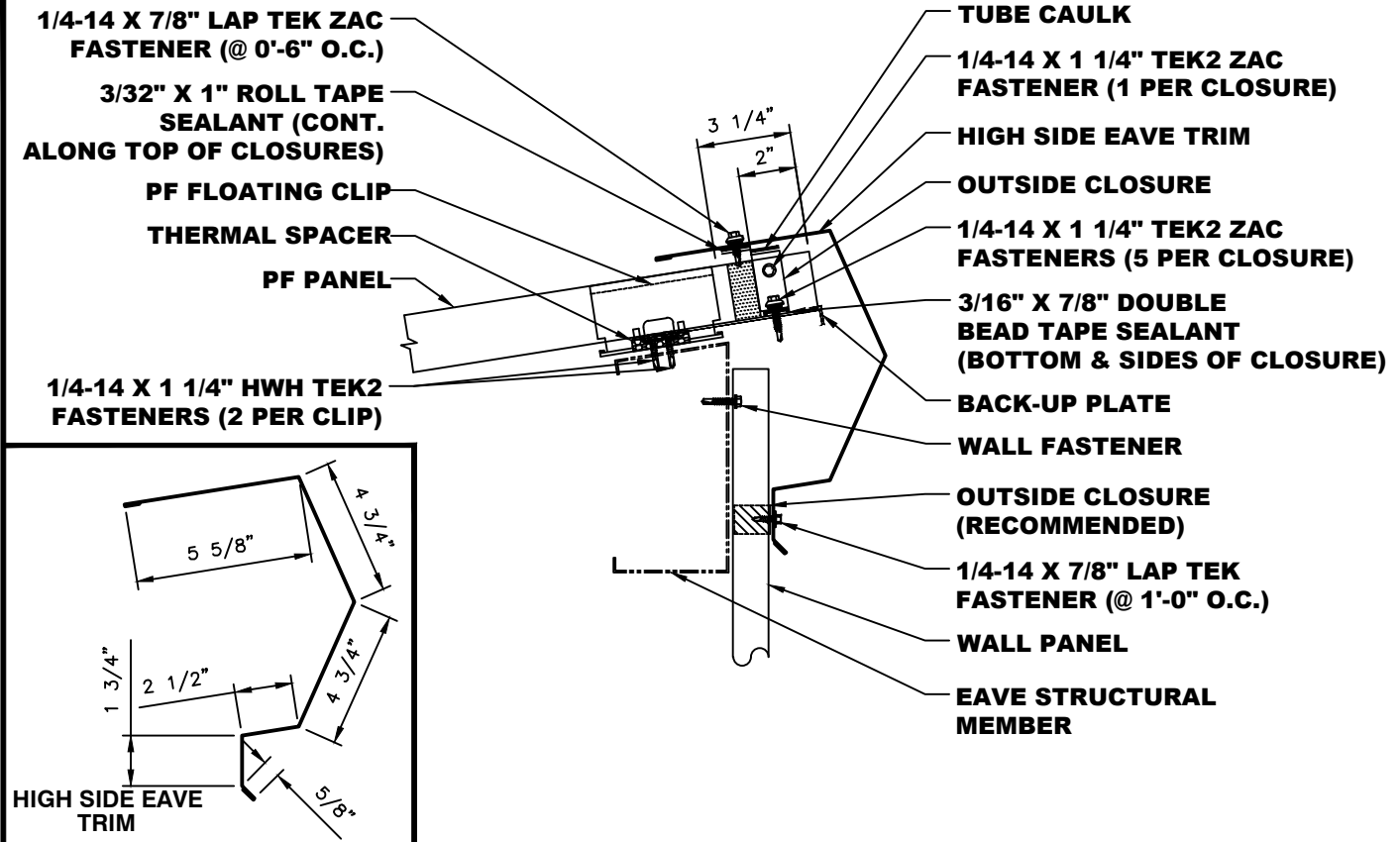

- NOTES:**
1. High Side Eave Flashing to run from out of wall to out of wall.
 2. Place 3/32" x 1" Roll Tape Sealant on top flange of Outside Closures continuously along Ridge.
 3. Attach High Side Eave Flashing to Outside Closures with 1/4-14 x 7/8" Lap Tek ZAC fasteners at 6" O.C.
 4. Trim pieces lap 2". Apply 3/32" x 3/8" Butyl Tape or Butyl Tube Sealant at trim laps and secure trim joint with Pop Rivets as shown on page C-36.

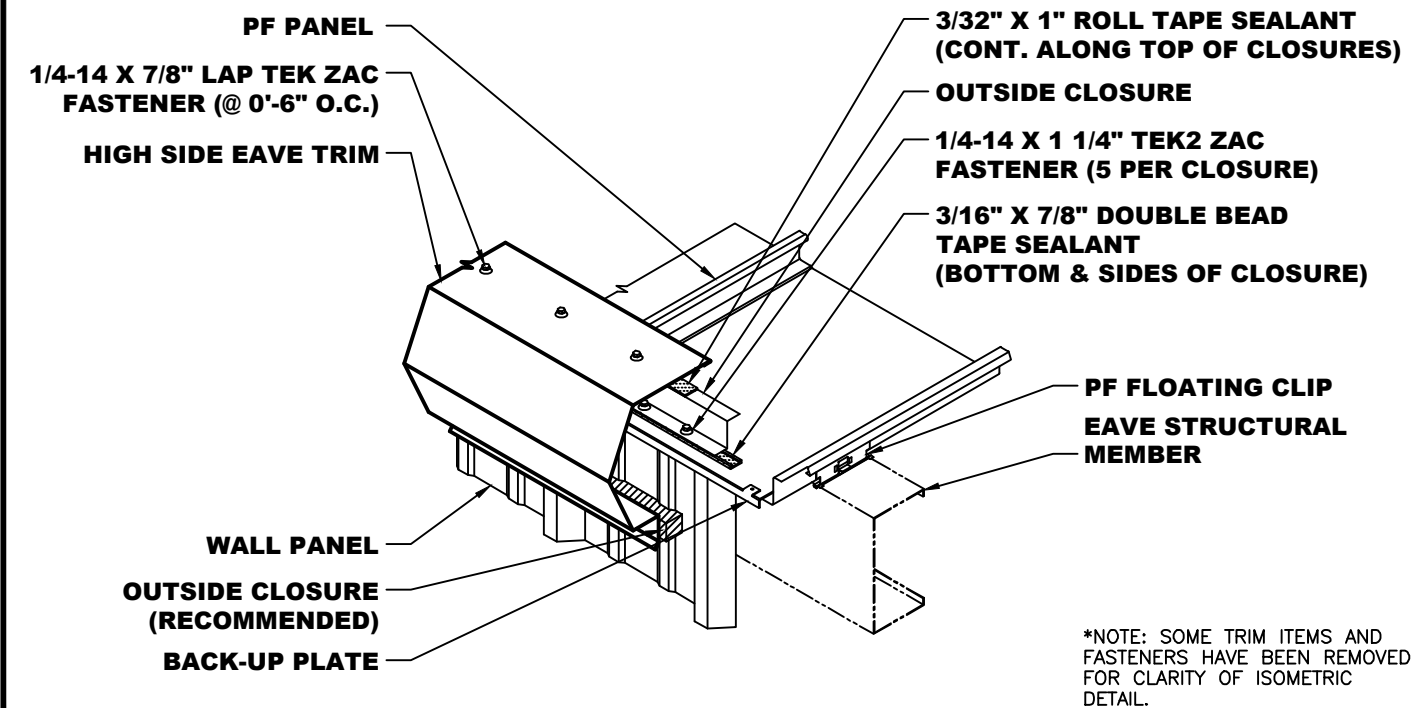

PF FIXED HIP DETAIL

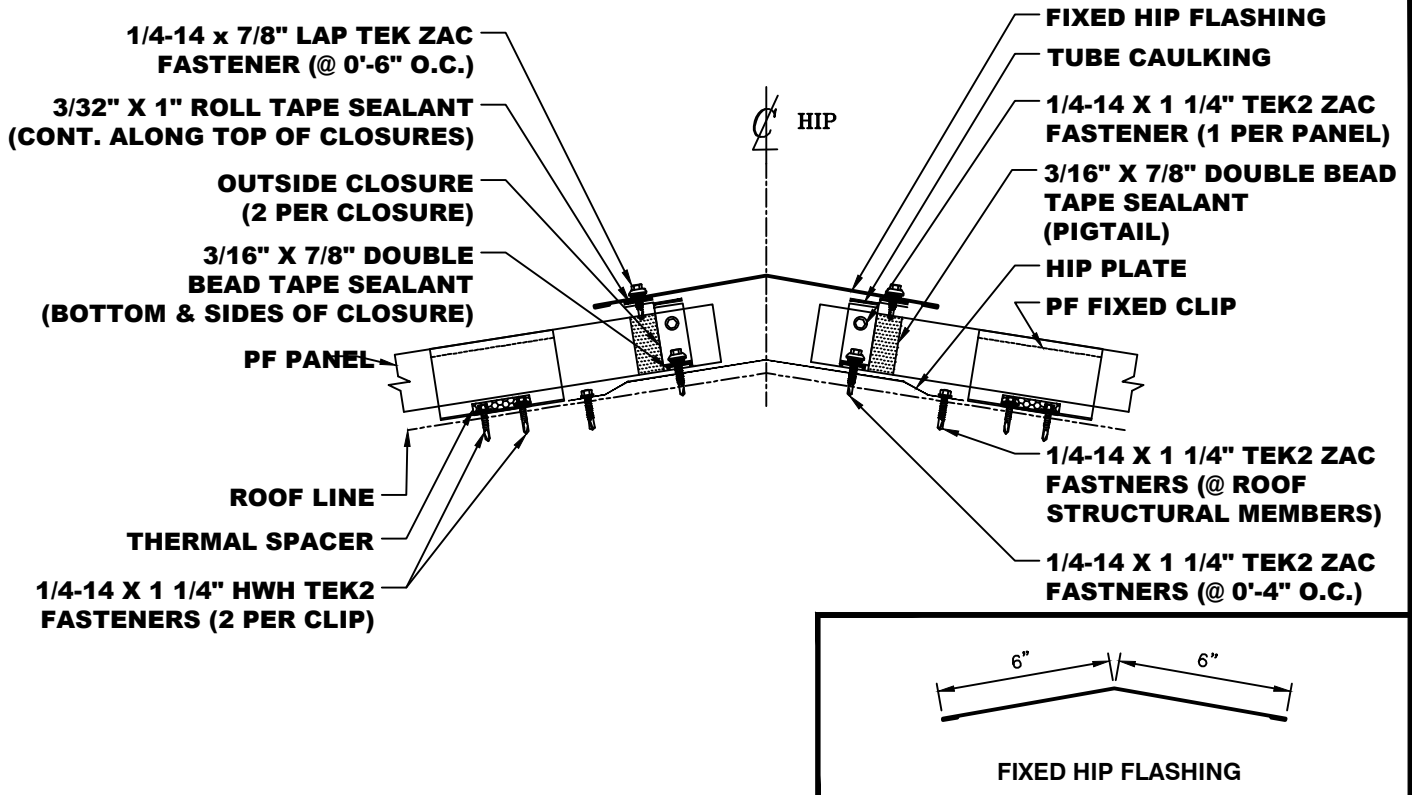

- NOTES:**
1. Cut panels to required bevel for Hip condition.
 2. Two Outside Closures required per panel. Cut off, cut out, slit and bend to required bevel.
 3. Install closures over 3/16" x 7/8" Double Bead Tape Sealant and fasten with 1/4-14 x 1 1/4" Tek2 ZAC fasteners at 4" O.C.
 4. Apply 3/32" x 1" Butyl Tape on top flange of Outside Closure continuously along length of Hip.
 5. Fill void areas with Tube Caulking.
 6. Install Hip Flashing from eave to ridge. Trim joint laps are to be 2" (min.) Apply 3/32" x 1" Roll Tape Sealant or 3/16" Ø bead of Tube Butyl at lap joints. Fasten with 1/4-14 x 7/8" Lap Tek ZAC fasteners at 3" O.C.
 7. Attach Hip Flashing to top flange of Outside Closures with 1/4-14 x 7/8" Lap Tek ZAC fasteners at 6" O.C.

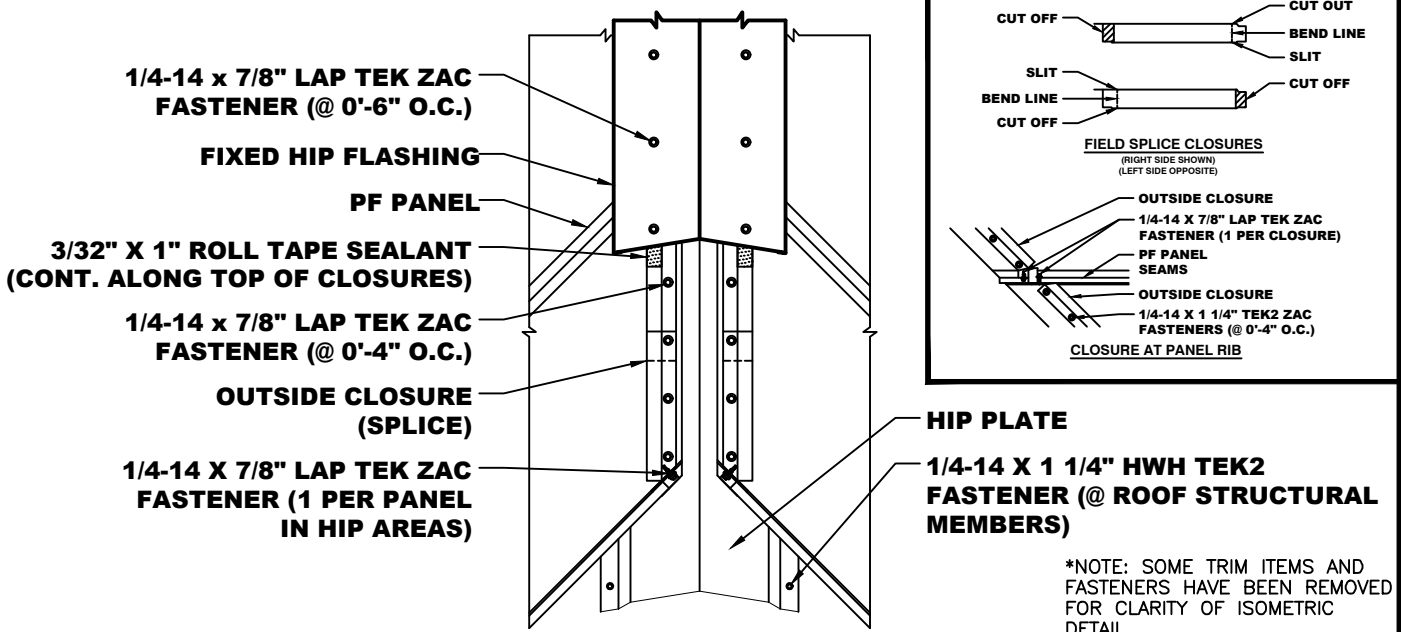

PF FLOATING HIP DETAIL

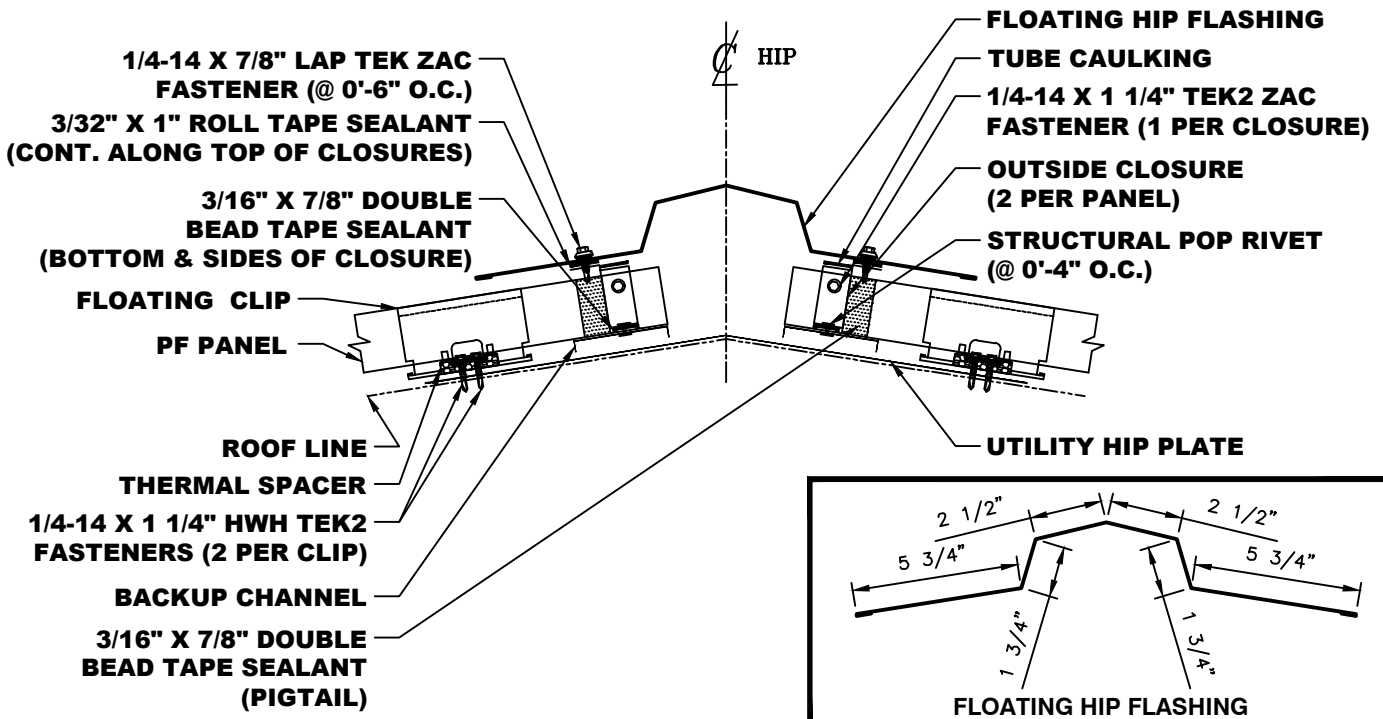

- NOTES:**
1. Cut panels to required bevel for Hip condition.
 2. Two Outside Closures required per panel. Cut off, cut out, slit and bend to required bevel.
 3. Install closures over 3/16" x 7/8" Double Bead Tape Sealant and fasten with Structural Pop Rivets at 4" O.C.
 4. Apply 3/32" x 1" Butyl Tape on top flange of Outside Closure continuously along length of Hip.
 5. Fill void areas with Tube Caulking.
 6. Install Hip Flashing from eave to ridge. Trim joint laps are to be 2" (min.) Apply 3/32" x 1" Roll Tape Sealant or 3/16" Ø bead of Tube Butyl at lap joints. Fasten with 1/4-14 x 7/8" Lap Tek ZAC fasteners at 3" O.C.
 7. Attach Hip Flashing to top flange of Outside Closures with 1/4-14 x 7/8" Lap Tek ZAC fasteners at 6" O.C.

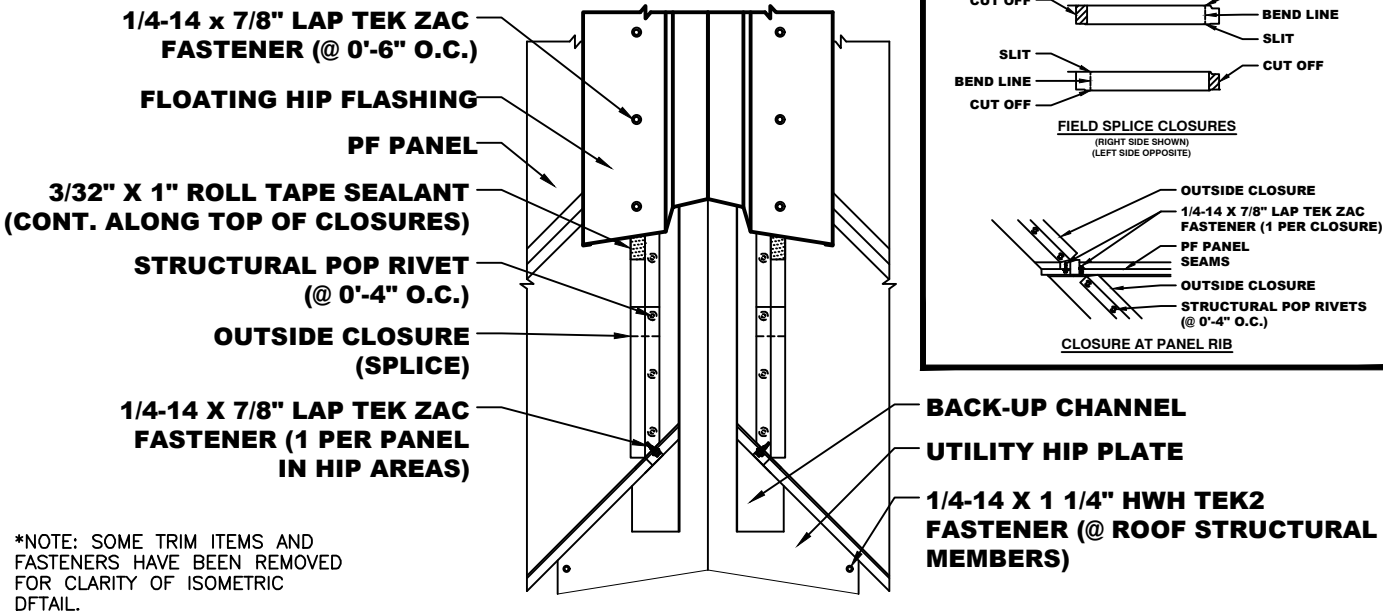

*NOTE: SOME TRIM ITEMS AND FASTENERS HAVE BEEN REMOVED FOR CLARITY OF ISOMETRIC DFTAIL.

PF FIXED RAKE START DETAIL

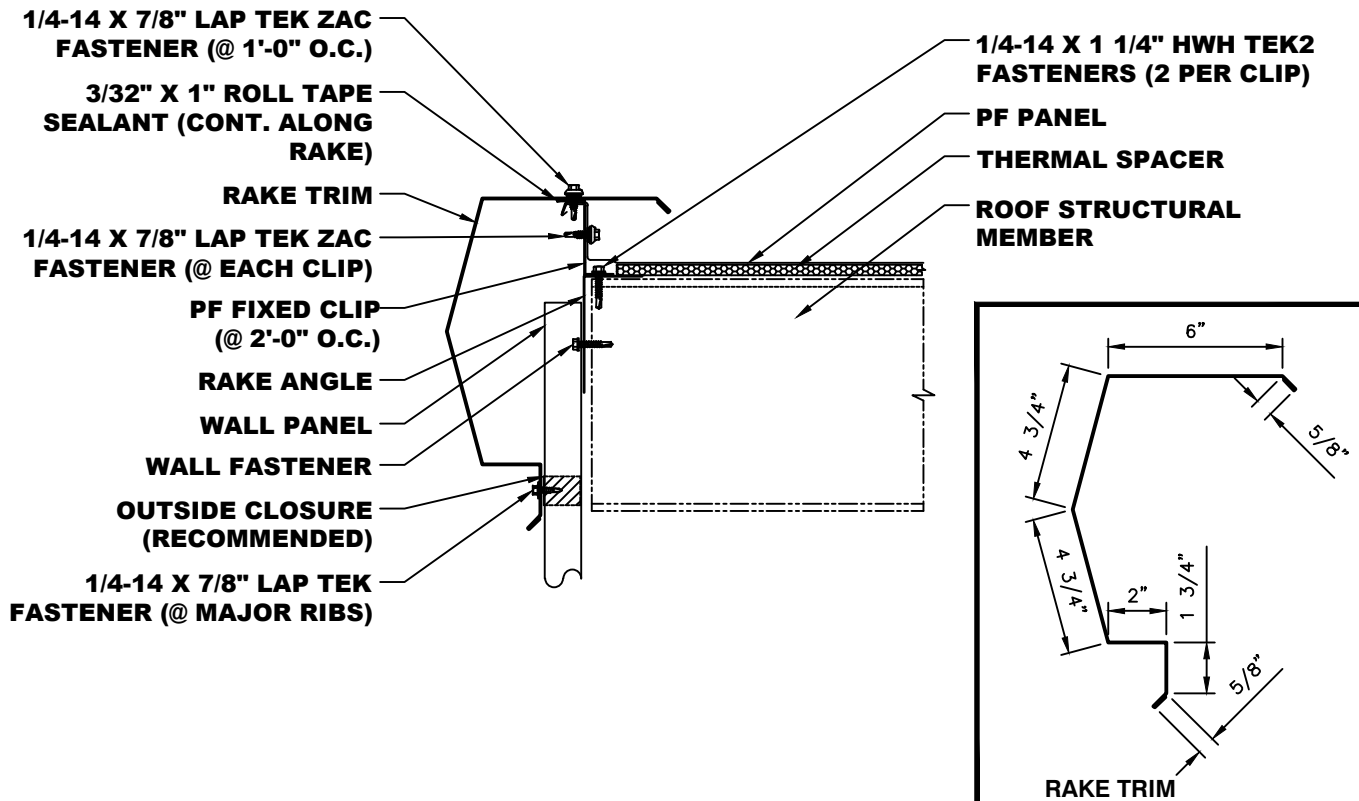

- NOTES:**
1. Rake Trim to start even with face of sidewall panels.
 2. Place 3/32" x 1" Roll Tape Sealant on top of panel leg continuously along Rake.
 3. Attach Rake Trim to roof panel with 1/4-14 x 7/8" Lap Tek fasteners at 1'-0" O.C.
 4. Attach Rake Trim to wall panels with 1/4-14 x 7/8" Lap Tek fasteners at major ribs.
 5. Trim pieces lap 2". Apply 3/32" x 3/8" Butyl Tape or Butyl Tube Sealant at trim laps and secure trim joint with Pop Rivets as shown on page C-36.

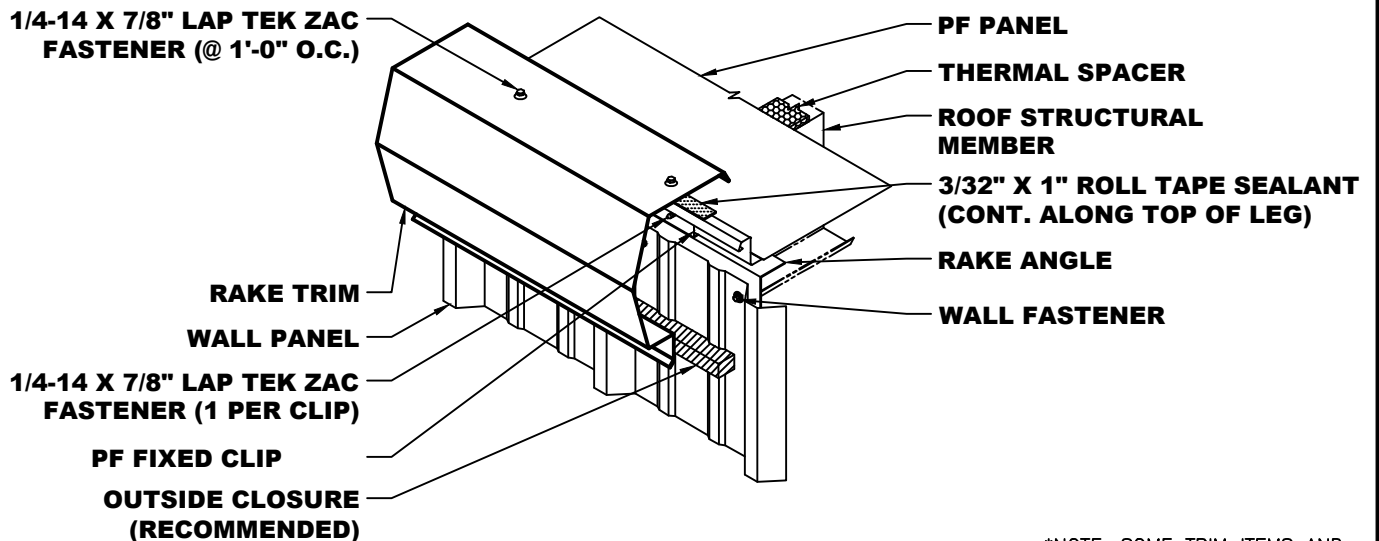

*NOTE: SOME TRIM ITEMS AND FASTENERS HAVE BEEN REMOVED FOR CLARITY OF ISOMETRIC

PF FLOATING RAKE START DETAIL

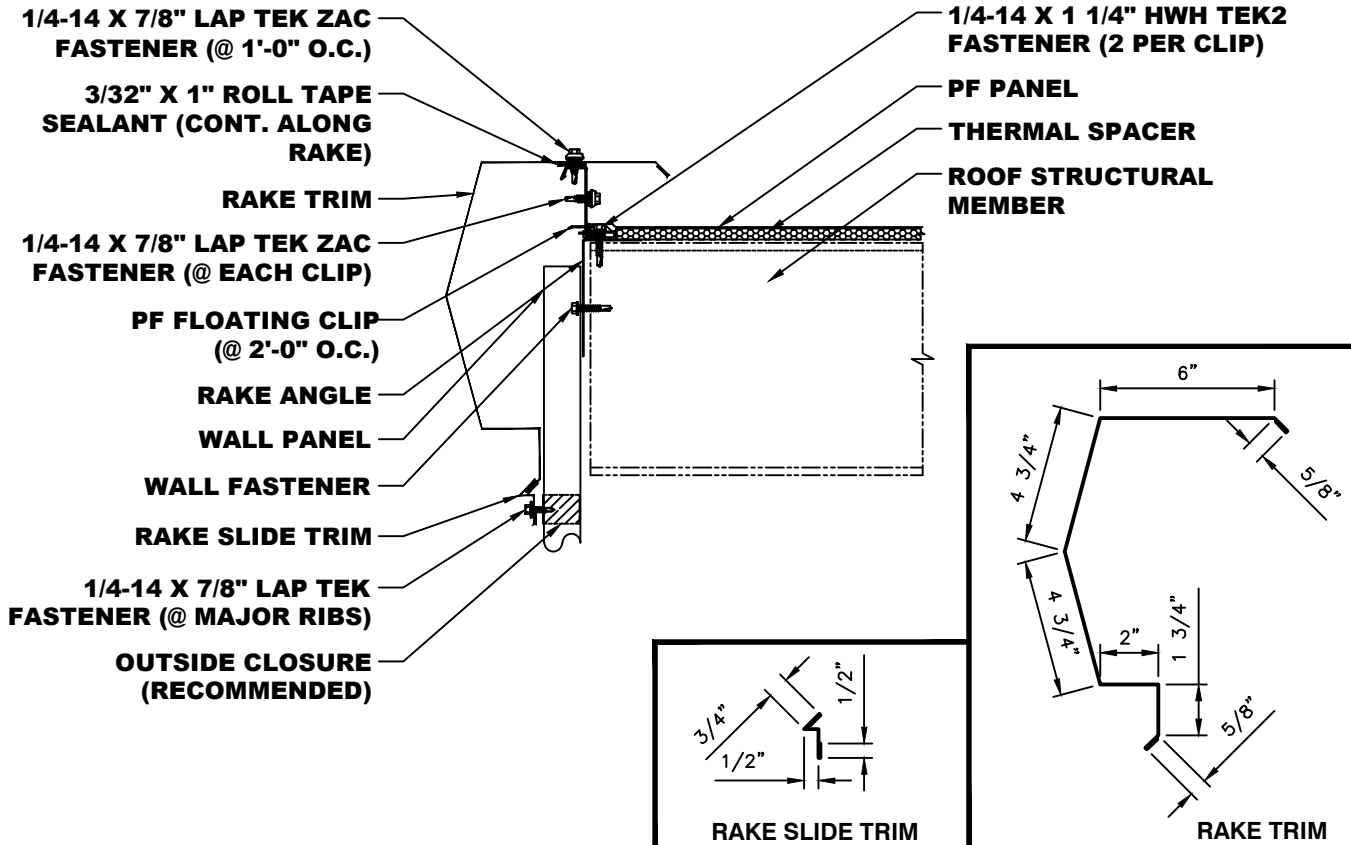

- NOTES:**
1. Rake Trim to start even with face of sidewall panels.
 2. Place 3/32" x 1" Roll Tape Sealant on top of panel leg continuously along Rake.
 3. Attach Rake Trim to roof panel with 1/4-14 x 7/8" Lap Tek fasteners at 1'-0" O.C.
 4. Attach Rake Slide Trim to wall panels with 1/4-14 x 7/8" Lap Tek fasteners at major ribs.
 5. Trim pieces lap 2". Apply 3/32" x 3/8" Butyl Tape or Butyl Tube Sealant at trim laps and secure trim joint with Pop Rivets as shown on page C-36.

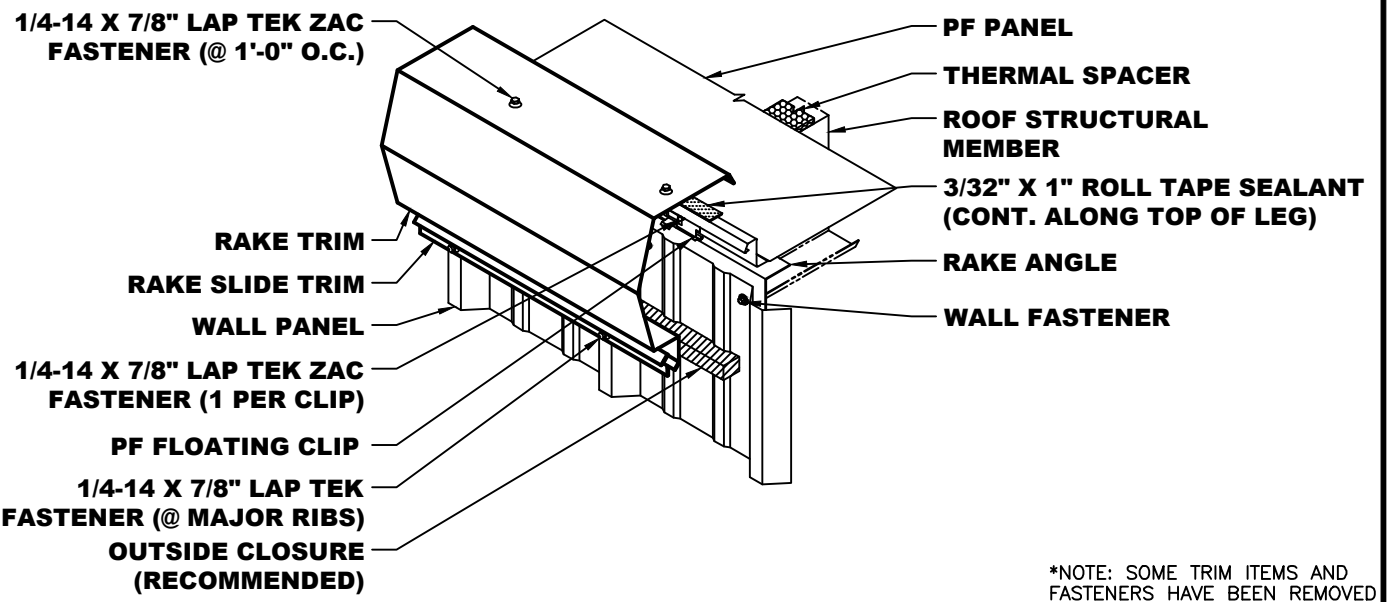

PF FIXED RAKE START DETAIL (OFF MODULE)

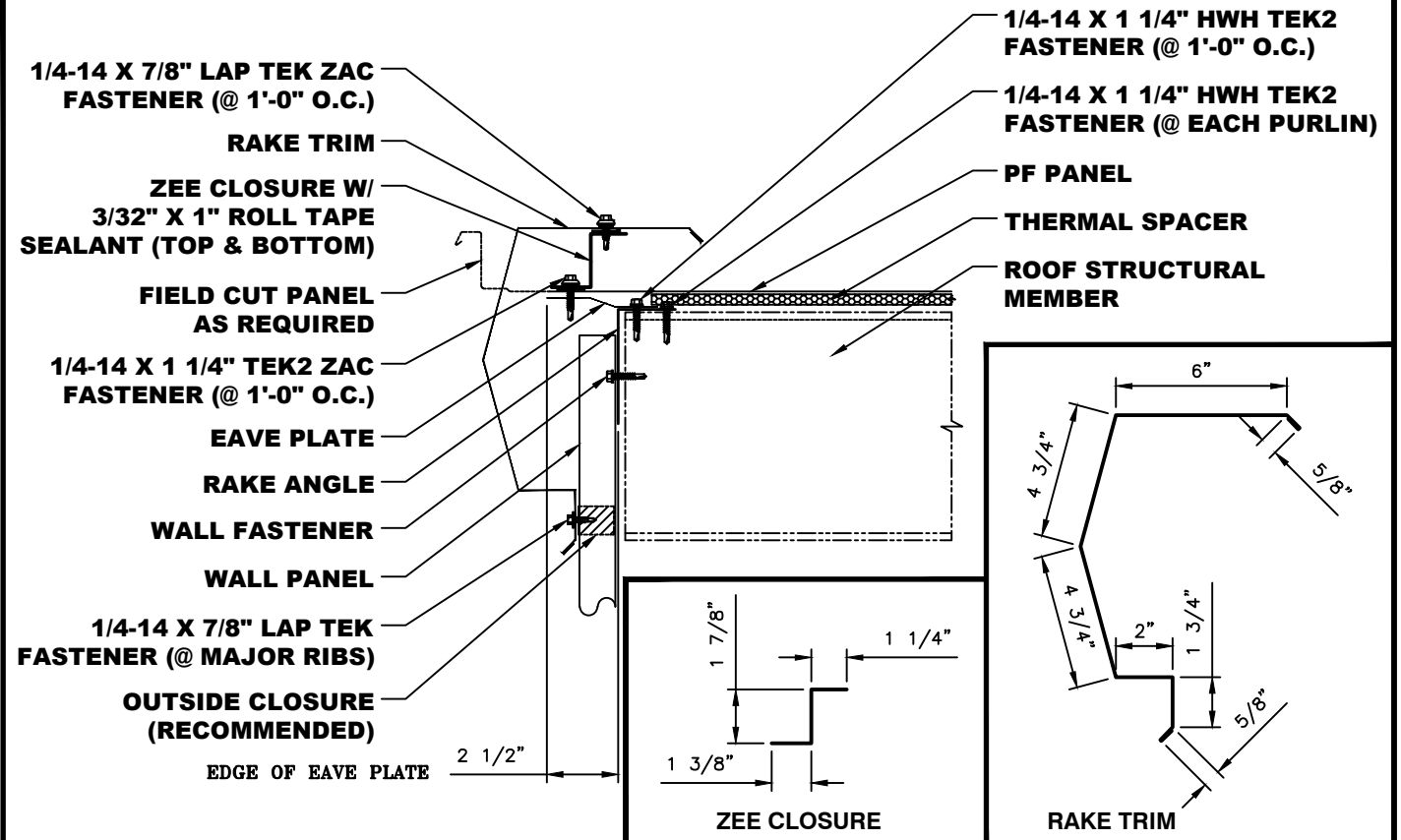

- NOTES:**
1. Rake Trim to start even with face of sidewall panels.
 2. Place 3/32" x 1" Roll Tape Sealant on top and bottom of Zee Closure the length of the rake.
 3. Attach Zee Closure with 1/4-14 x 1 1/4" Lap Tek ZAC fasteners at 1'-0" O.C. Install from Ridge to Eave to avoid "Back Water Laps". Place 3/32" x 3/8" Butyl Tape or 3/16" Ø bead of Butyl Tube Sealant in laps.
 4. Attach Rake Trim to Zee Closure with 1/4-14 x 7/8" Lap Tek fasteners at 1'-0" O.C.
 4. Attach Rake Trim to wall panels with 1/4-14 x 7/8" Lap Tek fasteners at major ribs.
 5. Trim pieces lap 2". Apply 3/32" x 3/8" Butyl Tape or Butyl Tube Sealant at trim laps and secure trim joint with Pop Rivets as shown on page C-36.

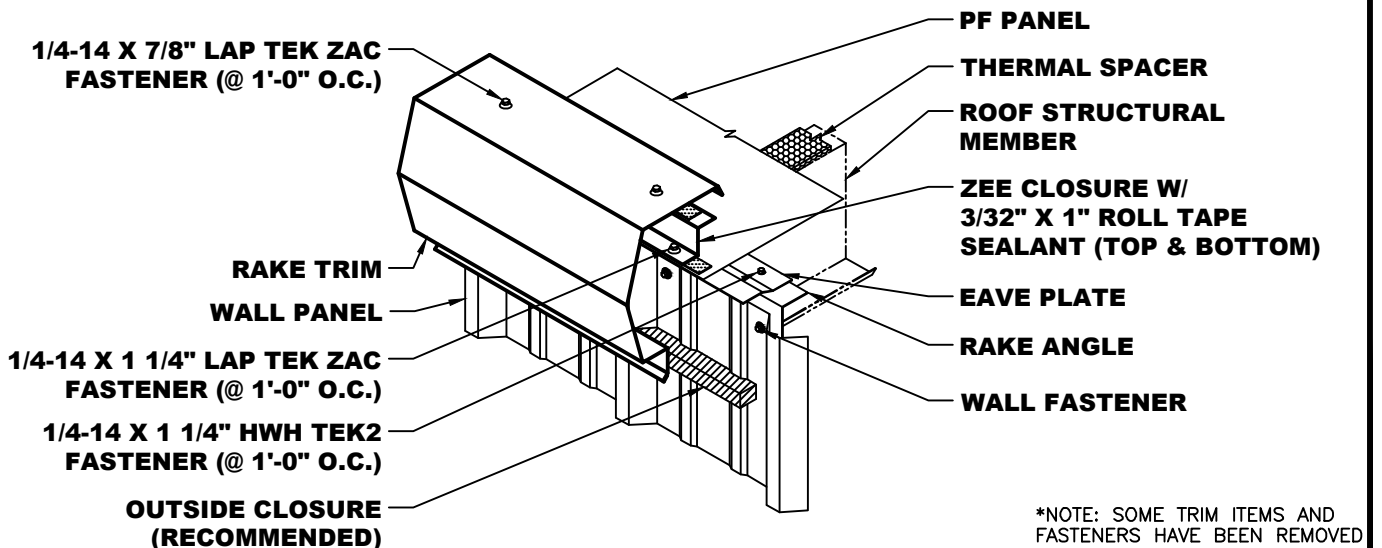

*NOTE: SOME TRIM ITEMS AND FASTENERS HAVE BEEN REMOVED FOR CLARITY OF ISOMETRIC DETAIL.

PF FLOATING RAKE START DETAIL (OFF MODULE)

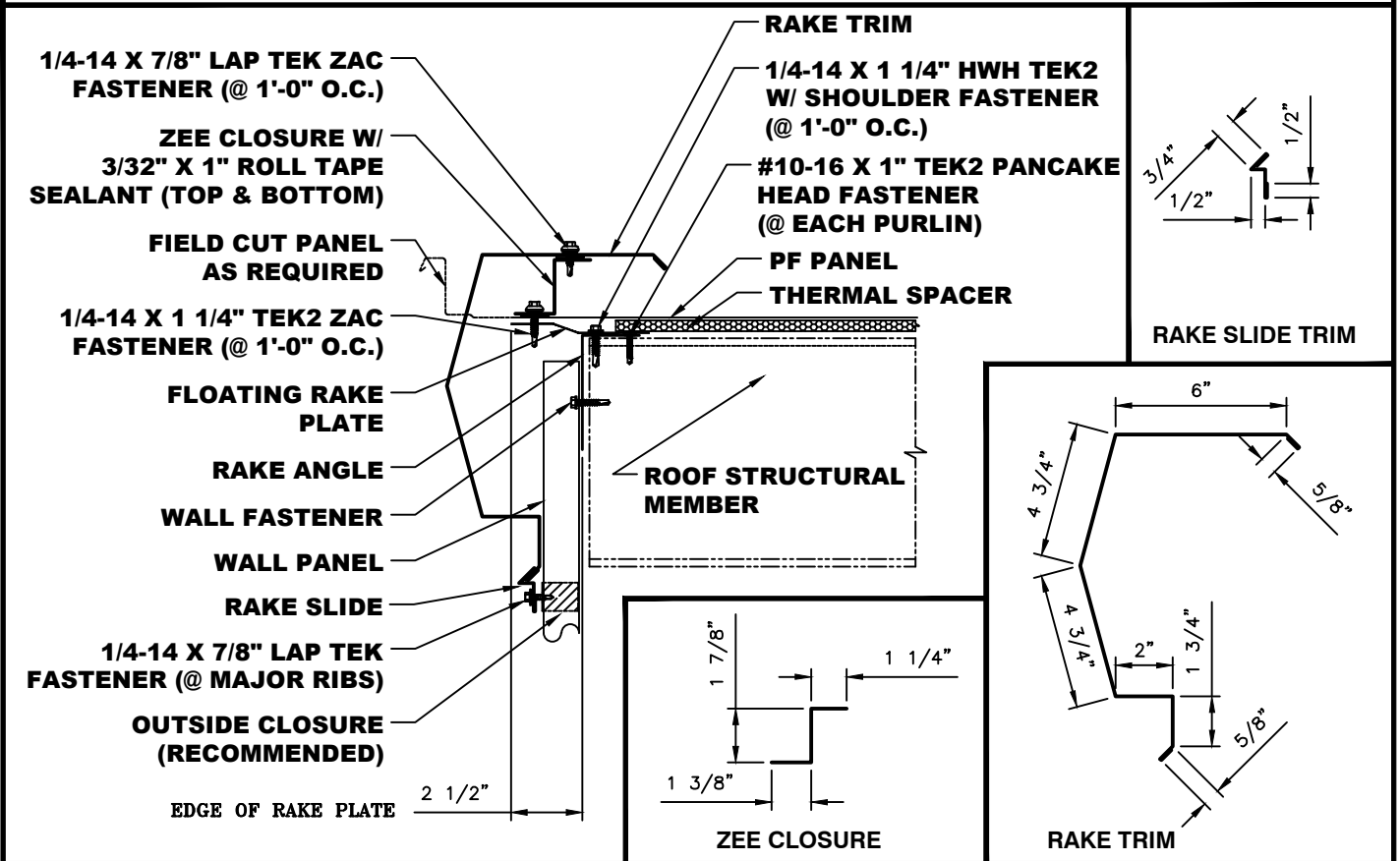

- NOTES:**
1. Rake Trim to start even with face of sidewall panels.
 2. Place 3/32" x 1" Roll Tape Sealant on top and bottom of Zee Closure the length of the rake.
 3. Attach Zee Closure with 1/4-14 x 1 1/4" Lap Tek ZAC fasteners at 1'-0" O.C. Install from Ridge to Eave to avoid "Back Water Laps". Place 3/32" x 3/8" Butyl Tape or 3/16" Ø bead of Butyl Tube Sealant in laps.
 4. Attach Rake Trim to Zee Closure with 1/4-14 x 7/8" Lap Tek fasteners at 1'-0" O.C.
 4. Attach Rake Trim to wall panels with 1/4-14 x 7/8" Lap Tek fasteners at major ribs.
 5. Trim pieces lap 2". Apply 3/32" x 3/8" Butyl Tape or Butyl Tube Sealant at trim laps and secure trim joint with Pop Rivets as shown on page C-36.

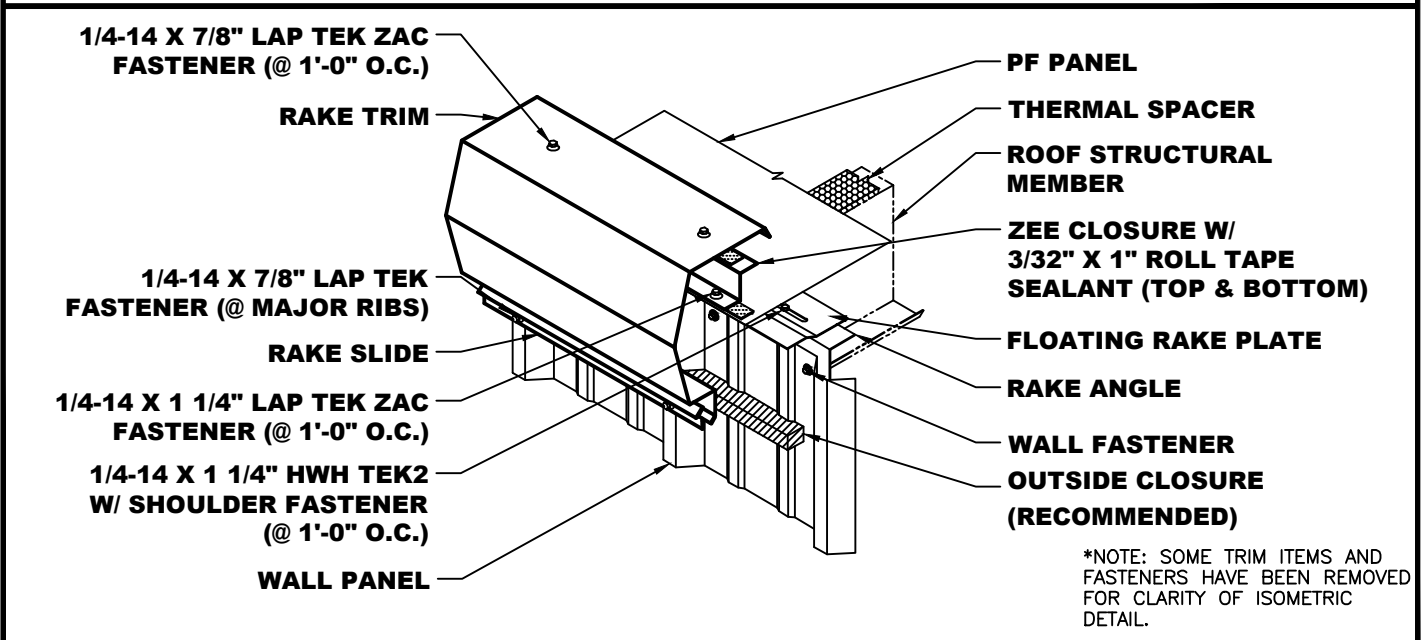

PF FIXED RAKE END DETAIL

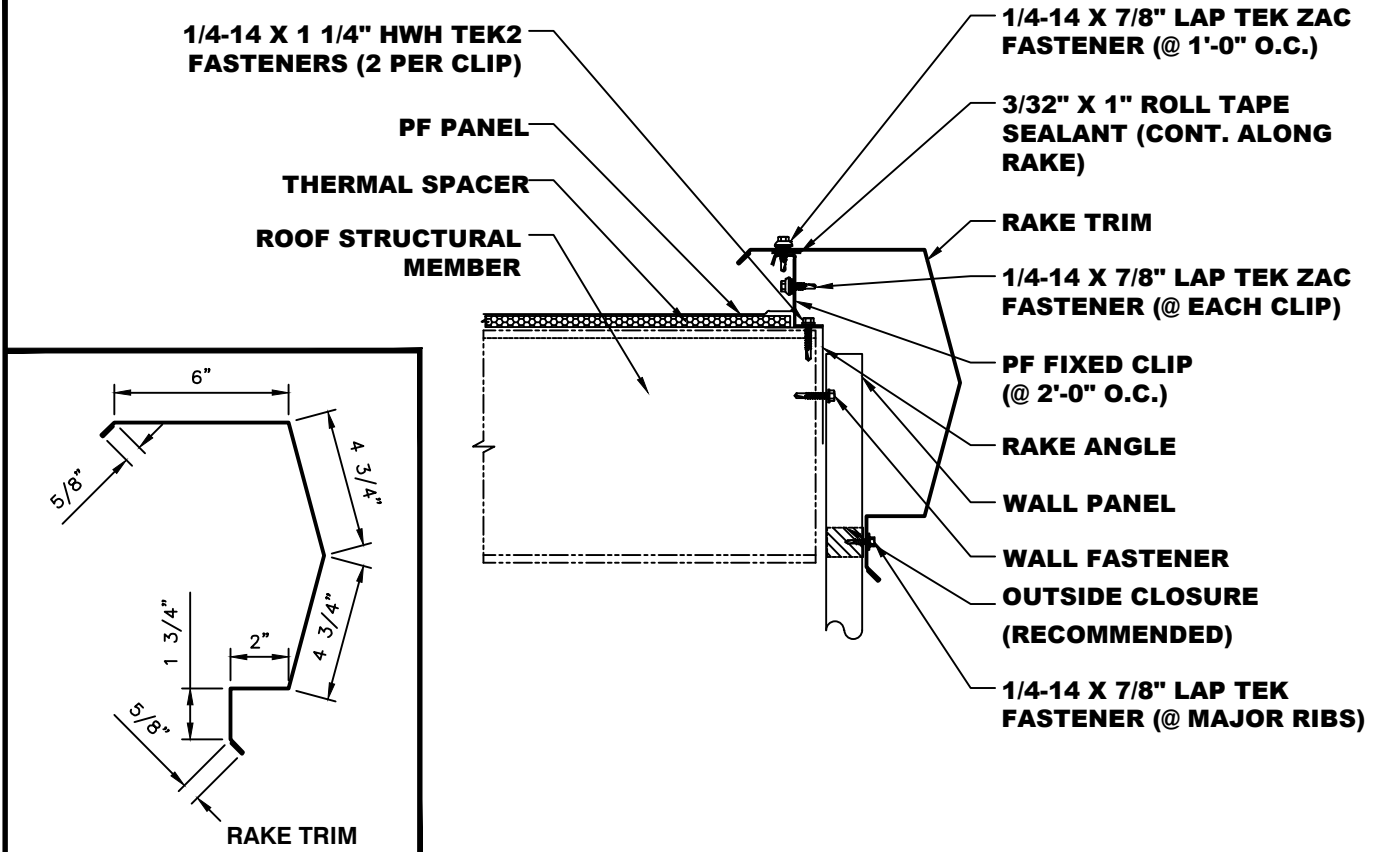

- NOTES:**
1. Rake Trim to start even with face of sidewall panels.
 2. Place 3/32" x 1" Roll Tape Sealant on top of panel leg continuously along Rake.
 3. Attach Rake Trim to roof panel with 1/4-14 x 7/8" Lap Tek ZAC fasteners at 1'-0" O.C.
 4. Attach Rake Trim to wall panels with 1/4-14 x 7/8" Lap Tek fasteners at major ribs.
 5. Trim pieces lap 2". Apply 3/32" x 3/8" Butyl Tape or Butyl Tube Sealant at trim laps and secure trim joint with Pop Rivets as shown on page C-36.

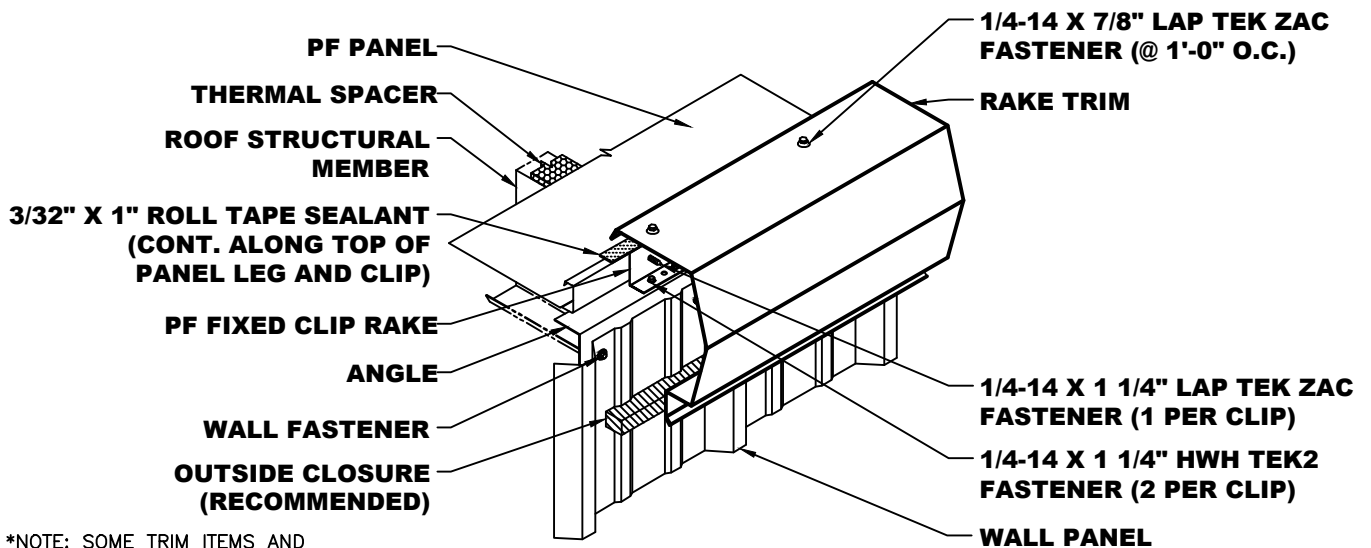

*NOTE: SOME TRIM ITEMS AND FASTENERS HAVE BEEN REMOVED FOR CLARITY OF ISOMETRIC DETAIL.

PF FLOATING RAKE END DETAIL

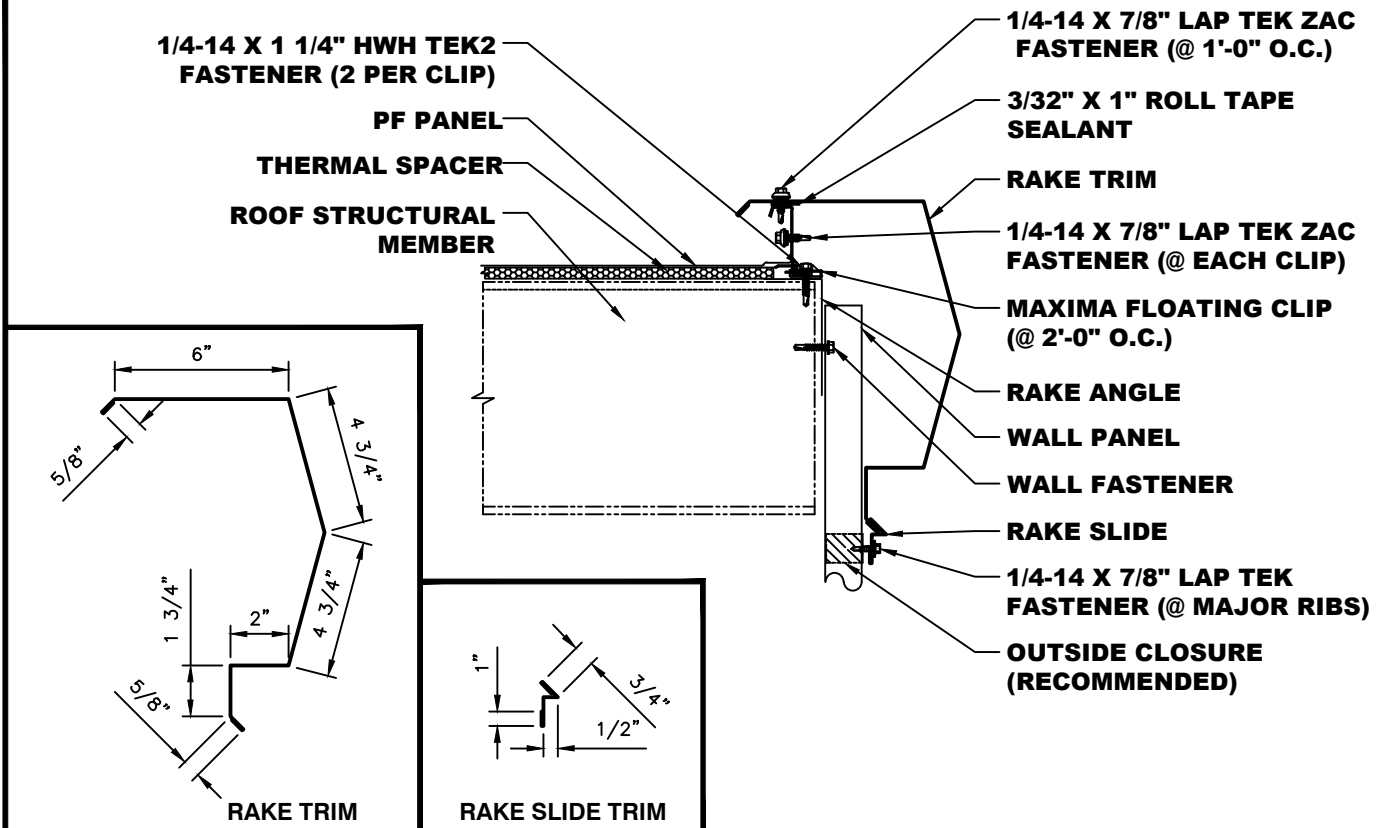

- NOTES:**
1. Rake Trim to start even with face of sidewall panels.
 2. Place 3/32" x 1" Roll Tape Sealant on top of panel leg continuously along Rake.
 3. Attach Rake Trim to roof panel with 1/4-14 x 7/8" Lap Tek fasteners at 1'-0" O.C.
 4. Attach Rake Slide Trim to wall panels with 1/4-14 x 7/8" Lap Tek ZAC fasteners at major ribs.
 5. Trim pieces lap 2". Apply 3/32" x 3/8" Butyl Tape or Butyl Tube Sealant at trim laps and secure trim joint with Pop Rivets as shown on page C-36.

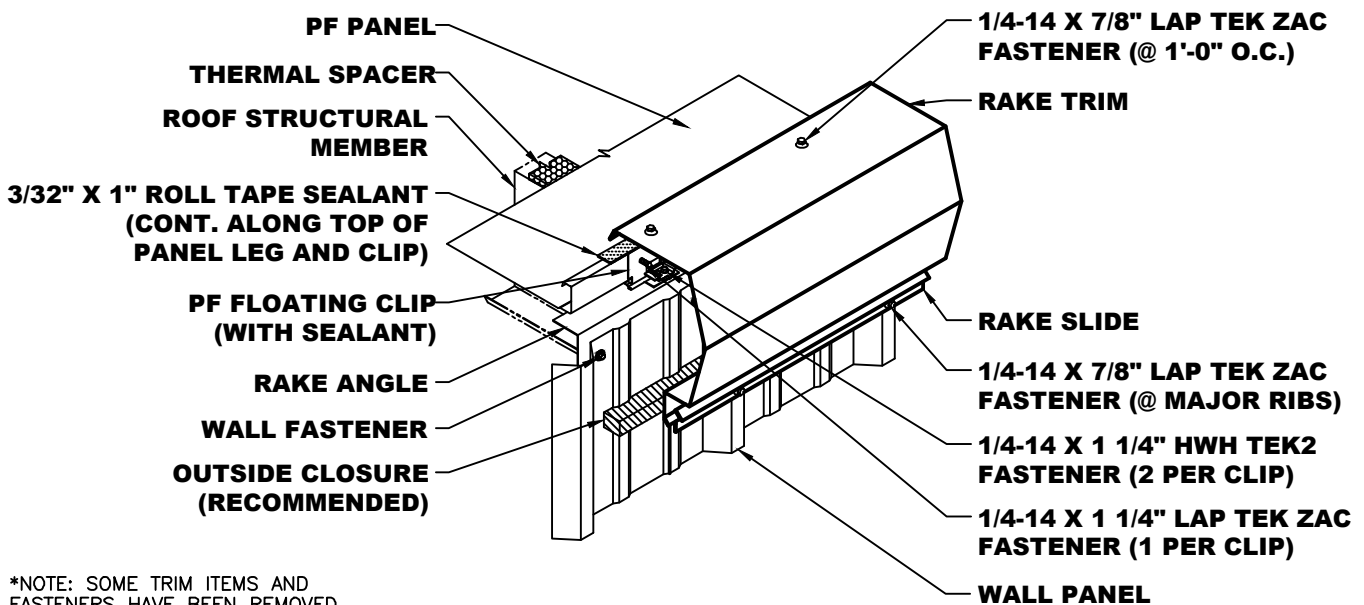

*NOTE: SOME TRIM ITEMS AND FASTENERS HAVE BEEN REMOVED FOR CLARITY OF ISOMETRIC DETAIL.

PF FIXED RAKE END DETAIL (OFF MODULE)

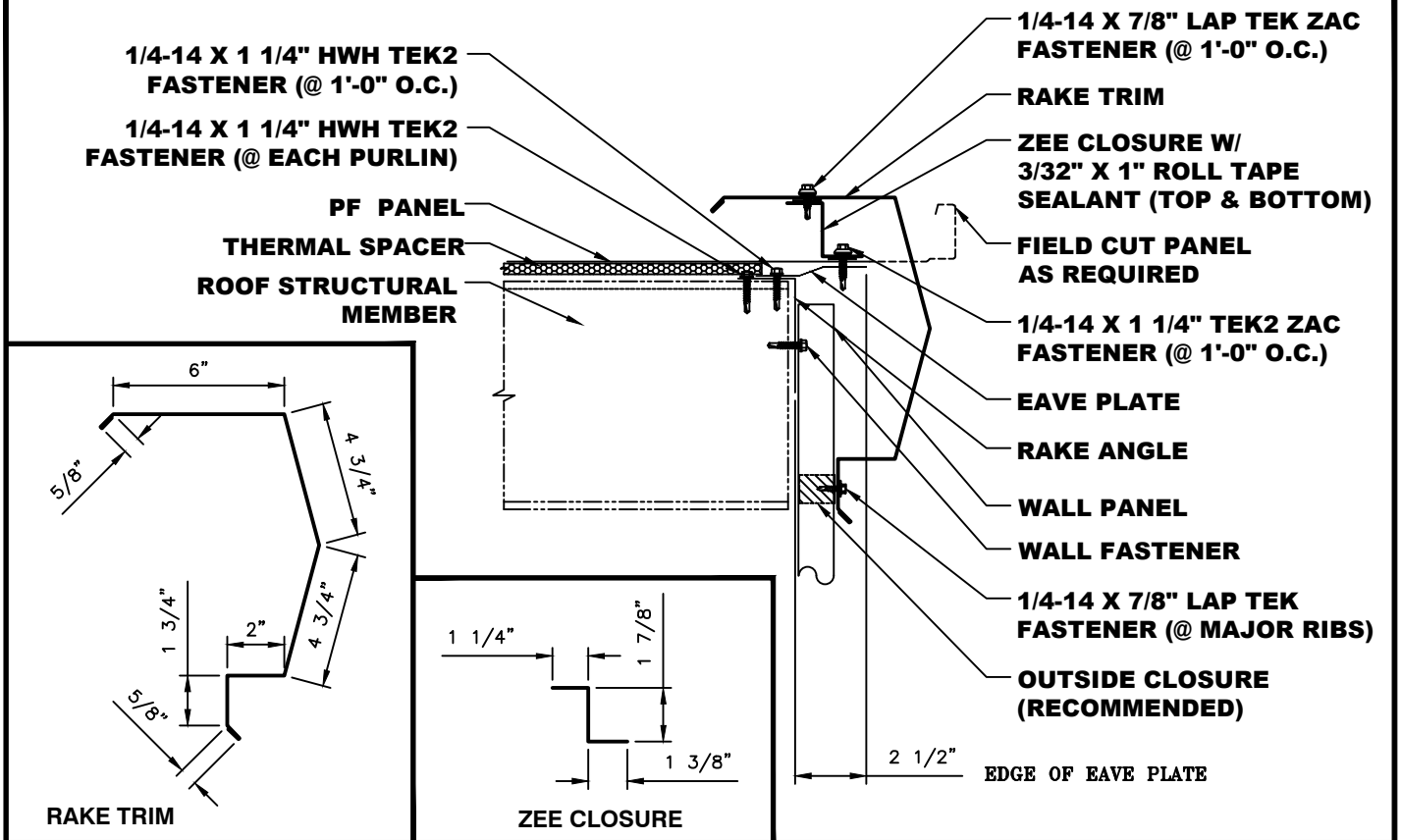

- NOTES:**
1. Rake Trim to start even with face of sidewall panels.
 2. Place 3/32" x 1" Roll Tape Sealant on top and bottom of Zee Closure the length of the rake.
 3. Attach Zee Closure with 1/4-14 x 1 1/4" Lap Tek ZAC fasteners at 1'-0" O.C. Install from Ridge to Eave to avoid "Back Water Laps". Place 3/32" x 3/8" Butyl Tape or 3/16" Ø bead of Butyl Tube Sealant in laps.
 4. Attach Rake Trim to Zee Closure with 1/4-14 x 7/8" Lap Tek ZAC fasteners at 1'-0" O.C.
 4. Attach Rake Trim to wall panels with 1/4-14 x 7/8" Lap Tek fasteners at major ribs.
 5. Trim pieces lap 2". Apply 3/32" x 3/8" Butyl Tape or Butyl Tube Sealant at trim laps and secure trim joint with Pop Rivets as shown on page C-36.

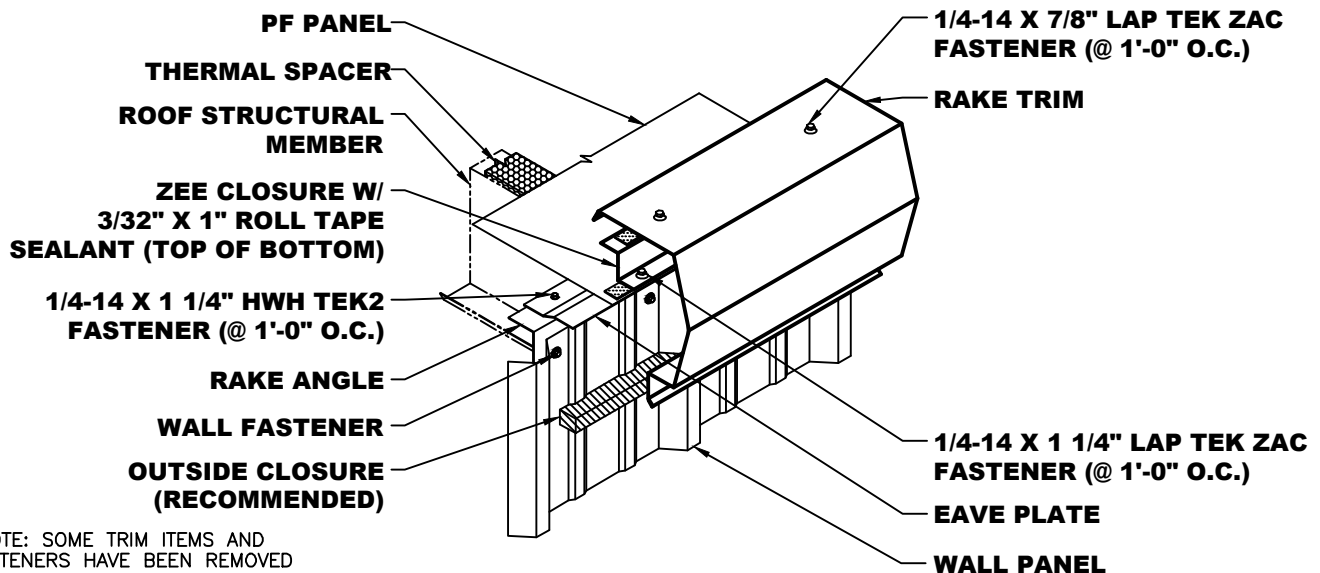

*NOTE: SOME TRIM ITEMS AND FASTENERS HAVE BEEN REMOVED FOR CLARITY OF ISOMETRIC DETAIL.

PF FLOATING RAKE END DETAIL (OFF MODULE)

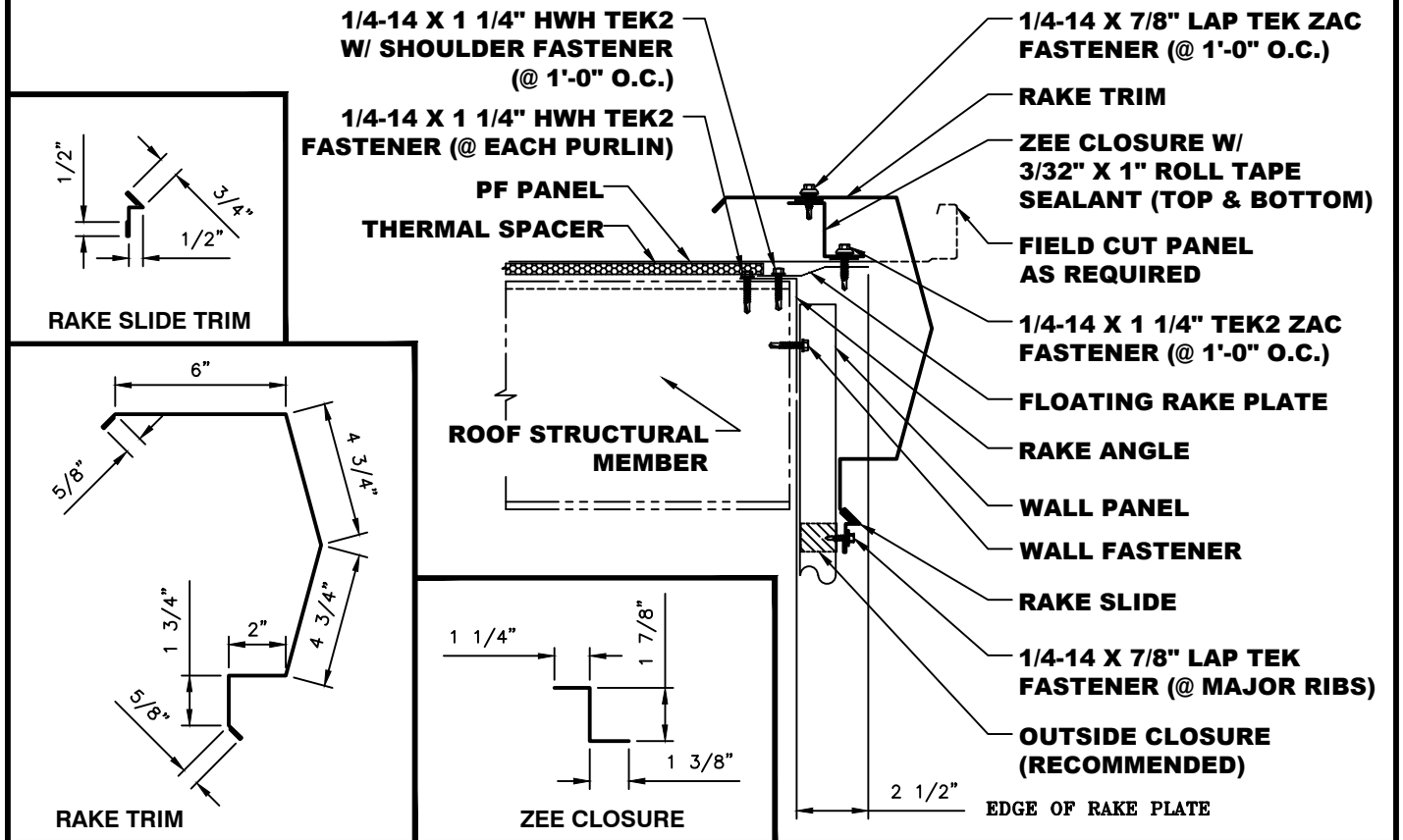

- NOTES:**
1. Rake Trim to start even with face of sidewall panels.
 2. Place 3/32" x 1" Roll Tape Sealant on top and bottom of Zee Closure the length of the rake.
 3. Attach Zee Closure with 1/4-14 x 1 1/4" Lap Tek ZAC fasteners at 1'-0" O.C. Install from Ridge to Eave to avoid "Back Water Laps". Place 3/32" x 3/8" Butyl Tape or 3/16" Ø bead of Butyl Tube Sealant in laps.
 4. Attach Rake Trim to Zee Closure with 1/4-14 x 7/8" Lap Tek ZAC fasteners at 1'-0" O.C.
 5. Attach Rake Trim to wall panels with 1/4-14 x 7/8" Lap Tek fasteners at major ribs.
 6. Trim pieces lap 2". Apply 3/32" x 3/8" Butyl Tape or Butyl Tube Sealant at trim laps and secure trim joint with Pop Rivets as shown on page C-36.

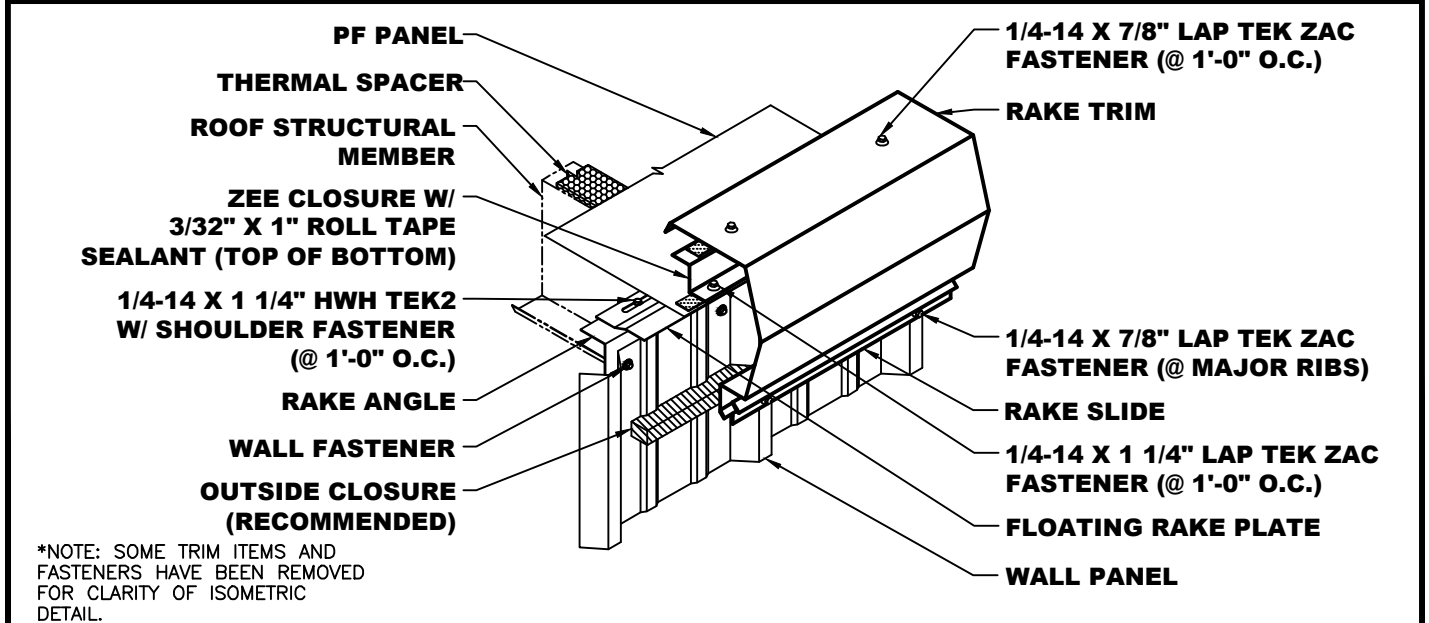

*NOTE: SOME TRIM ITEMS AND FASTENERS HAVE BEEN REMOVED FOR CLARITY OF ISOMETRIC DETAIL.

PF FIXED RAKE START TIE-IN DETAIL

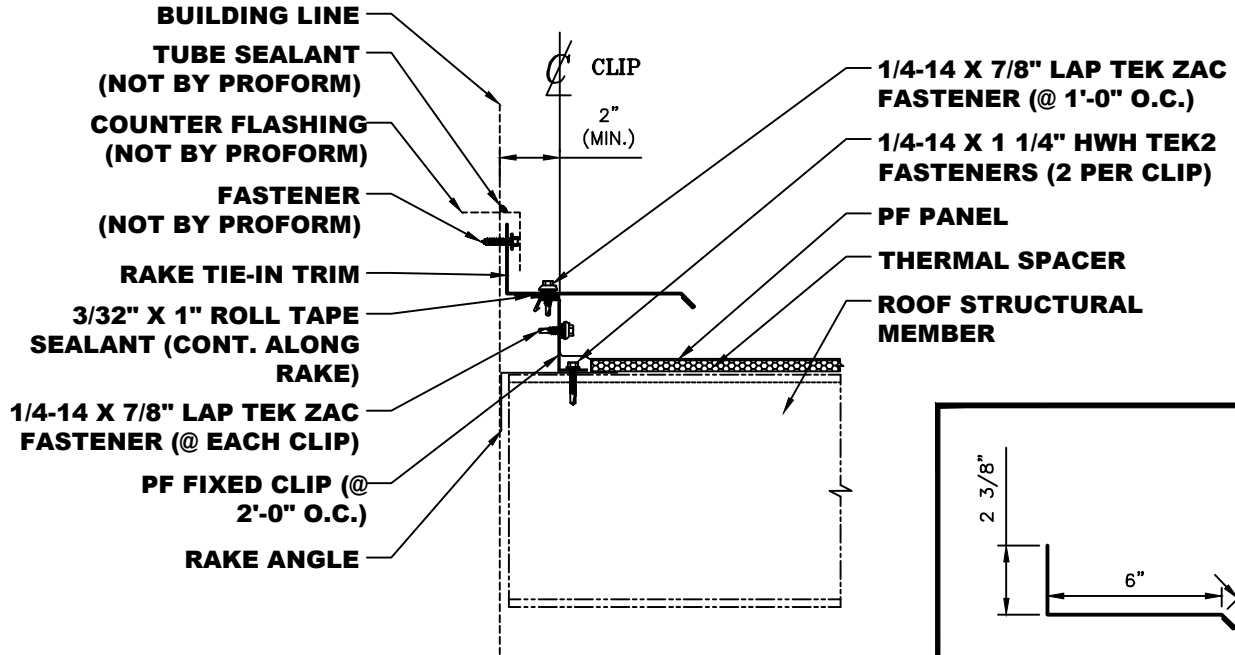

- NOTES:**
1. Rake Tie-In Trim to start even with building line.
 2. Place 3/32" x 1" Roll Tape Sealant along top of female leg of panel the length of the rake.
 3. Attach Rake Tie-In Trim with 1/4-14 x 7/8" Lap Tek ZAC fasteners at 1'-0" O.C. Place 3/32" x 3/8" Butyl Tape or 3/16" Ø bead of Butyl Tube Sealant in laps.
 4. Trim pieces lap 2".

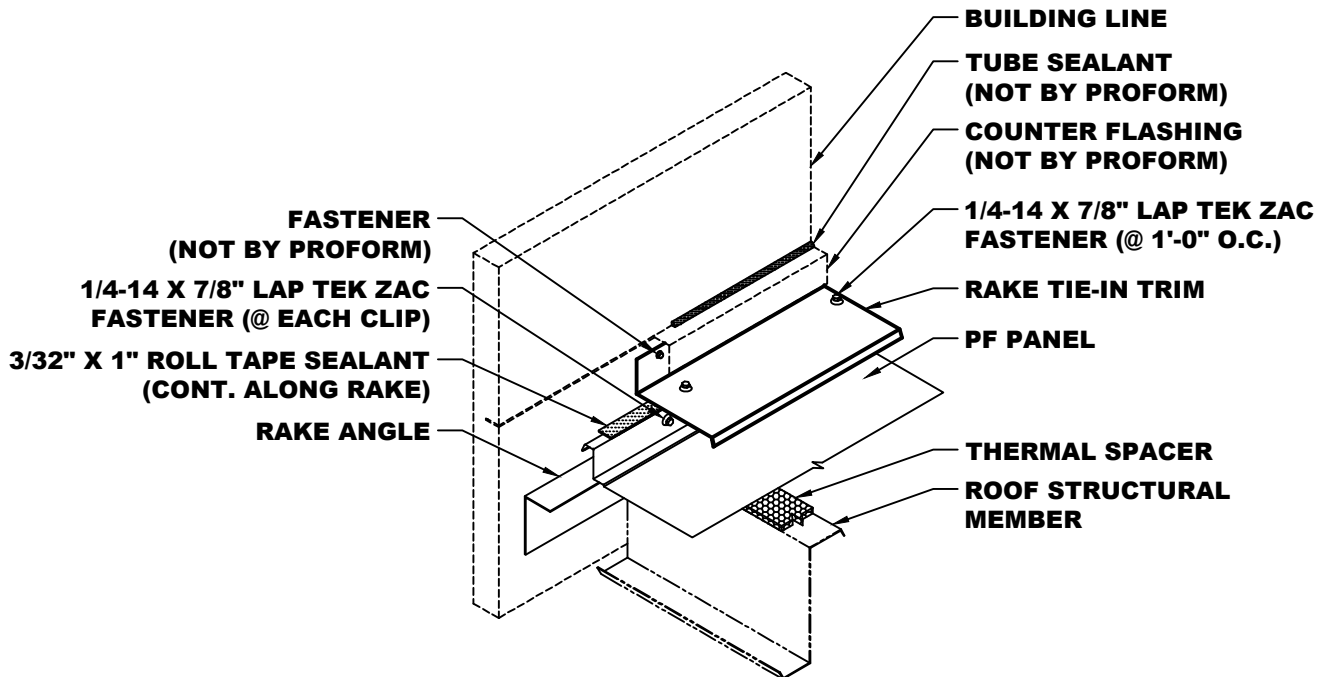

*NOTE: SOME TRIM ITEMS AND FASTENERS HAVE BEEN REMOVED FOR CLARITY OF ISOMETRIC DETAIL.

PF FLOATING RAKE START TIE-IN DETAIL

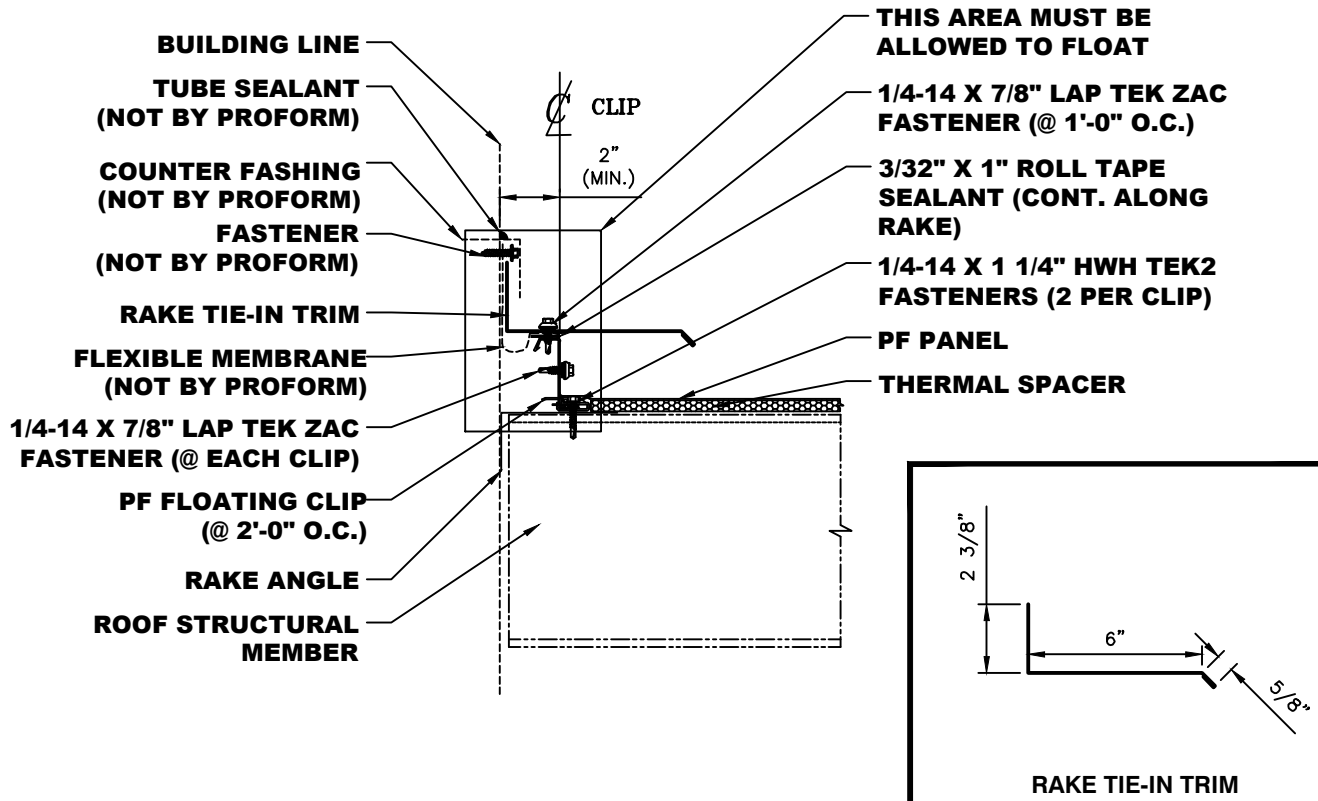

- NOTES:**
1. Rake Tie-In Trim to start even with building line.
 2. Place 3/32" x 1" Roll Tape Sealant along top of female leg of panel the length of the rake.
 3. Attach Rake Tie-In Trim with 1/4-14 x 7/8" Lap Tek ZAC fasteners at 1'-0" O.C. Place 3/32" x 3/8" Butyl Tape or 3/16" Ø bead of Butyl Tube Sealant in laps.
 4. Trim pieces lap 2".

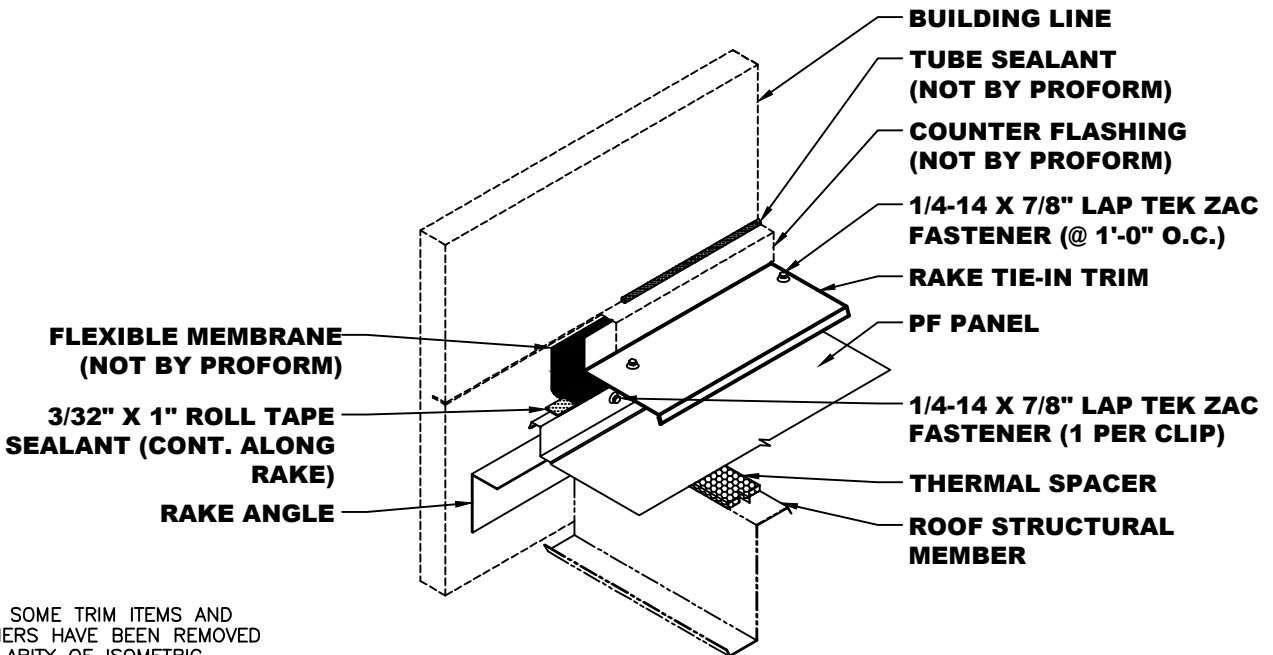

*NOTE: SOME TRIM ITEMS AND FASTENERS HAVE BEEN REMOVED FOR CLARITY OF ISOMETRIC DETAIL

PF FIXED RAKE START TIE-IN DETAIL (OFF MODULE)

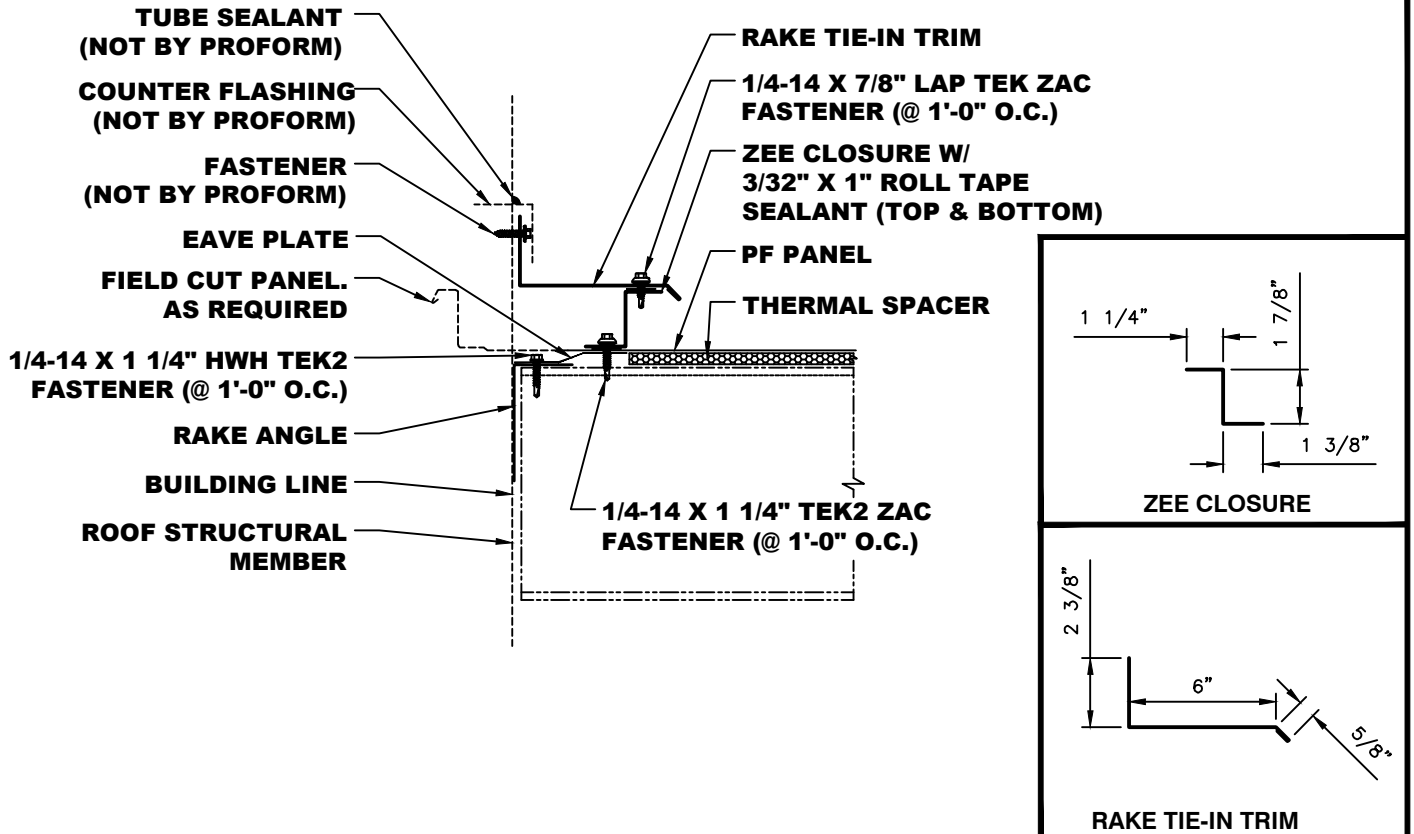

- NOTES:**
1. Rake Tie-In Trim to start even with building line.
 2. Place 3/32" x 1" Roll Tape Sealant on top and bottom of Zee Closure the length of the rake.
 3. Attach Zee Closure with 1/4-14 x 1 1/4" Lap Tek ZAC fasteners at 1'-0" O.C. Install from Ridge to Eave to avoid "Back Water Laps". Place 3/32" x 3/8" Butyl Tape or 3/16" Ø bead of Butyl Tube Sealant in laps.
 4. Attach Rake Tie-In Trim to Zee Closure with 1/4-14 x 7/8" Lap Tek ZAC fasteners at 1'-0" O.C.
 5. Trim pieces lap 2".

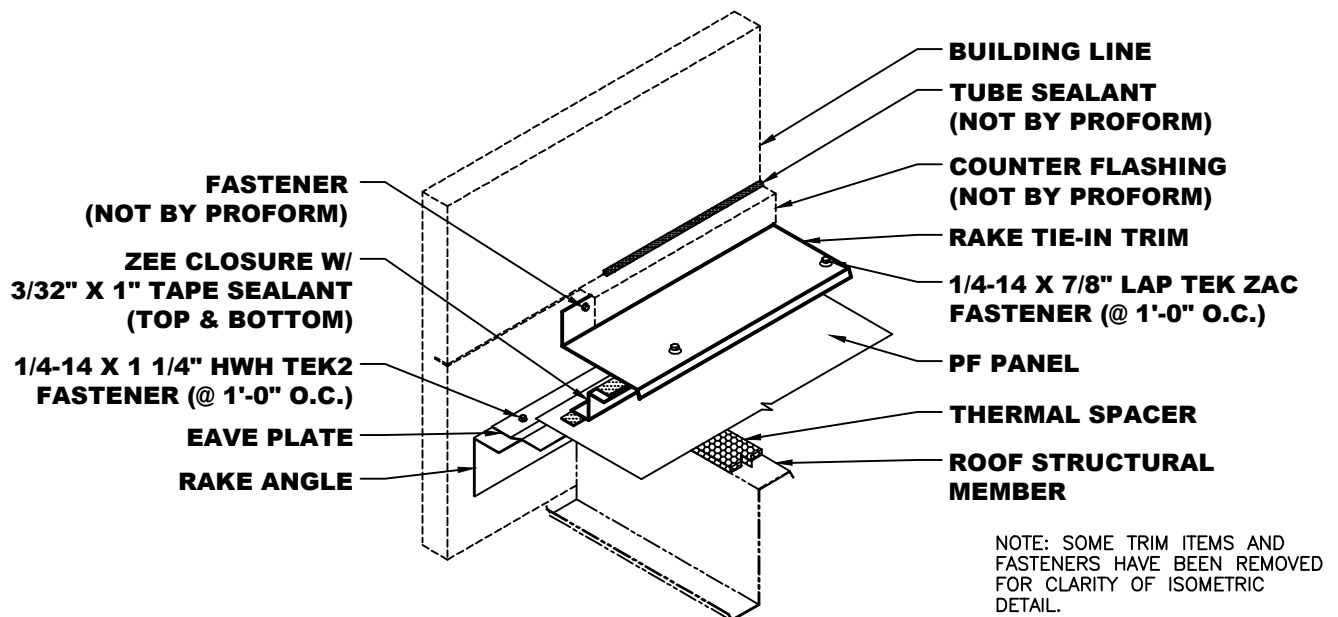

PF FLOATING RAKE START TIE-IN DETAIL (OFF MODULE)

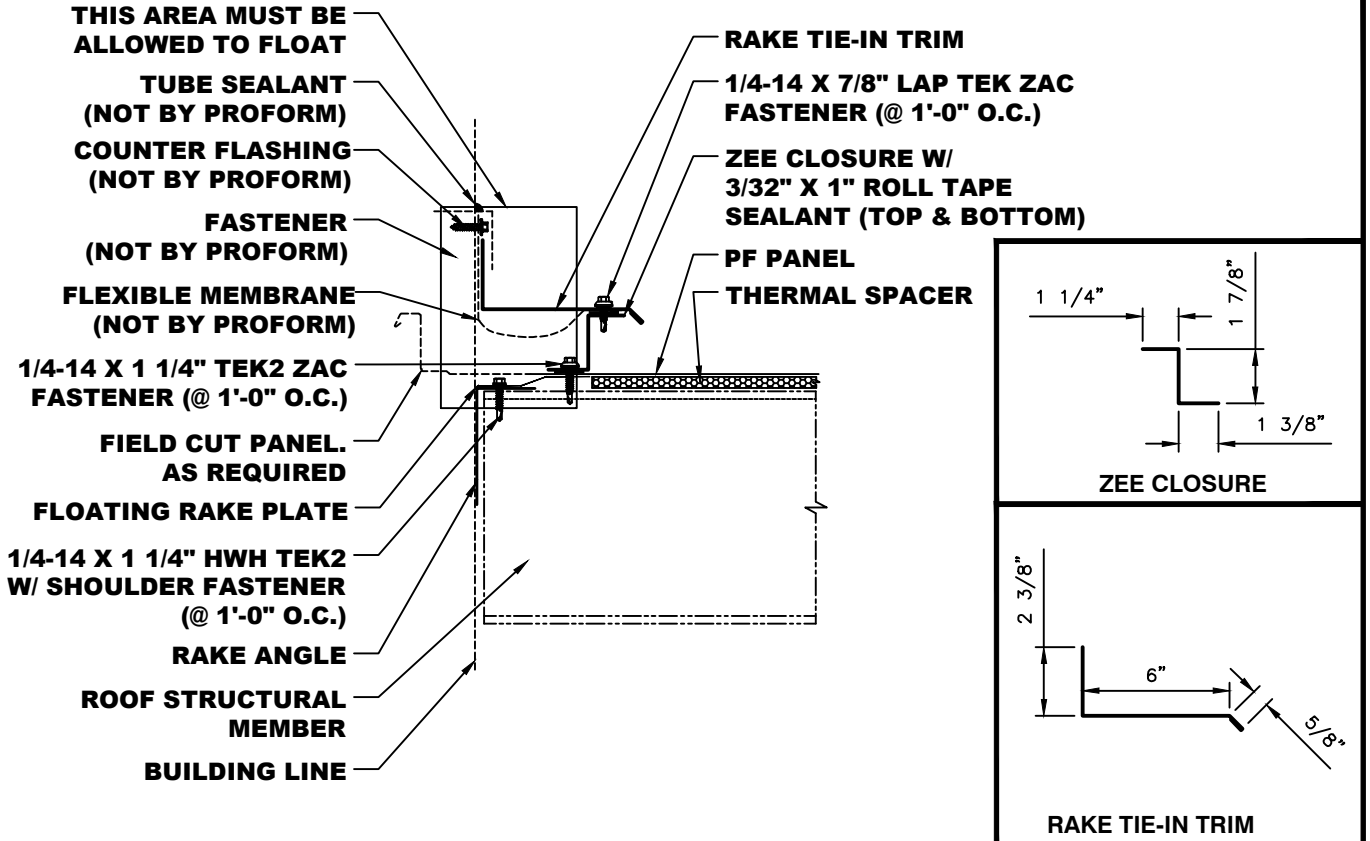

- NOTES:**
1. Rake Tie-In Trim to start even with building line.
 2. Place 3/32" x 1" Roll Tape Sealant on top and bottom of Zee Closure the length of the rake.
 3. Attach Zee Closure with 1/4-14 x 1 1/4" Lap Tek ZAC fasteners at 1'-0" O.C. Install from Ridge to Eave to avoid "Back Water Laps". Place 3/32" x 3/8" Butyl Tape or 3/16" Ø bead of Butyl Tube Sealant in laps.
 4. Attach Rake Tie-In Trim to Zee Closure with 1/4-14 x 7/8" Lap Tek ZAC fasteners at 1'-0" O.C.
 5. Trim pieces lap 2".

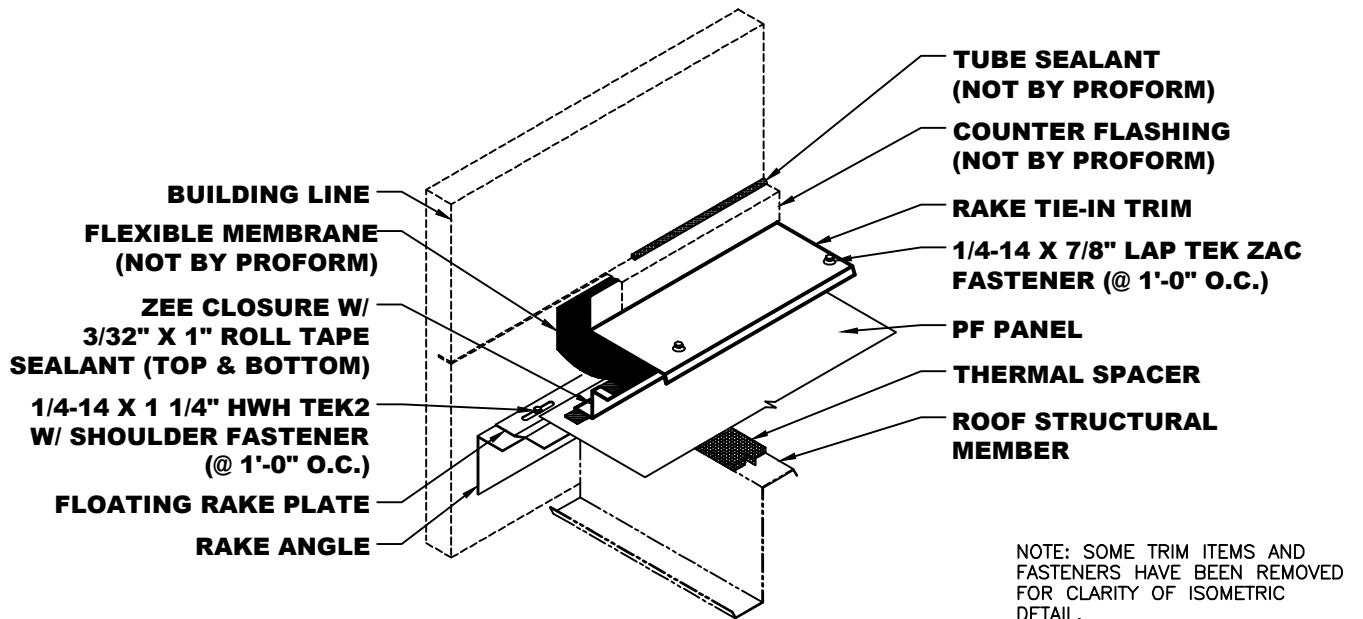

PF FIXED RAKE END TIE-IN DETAIL

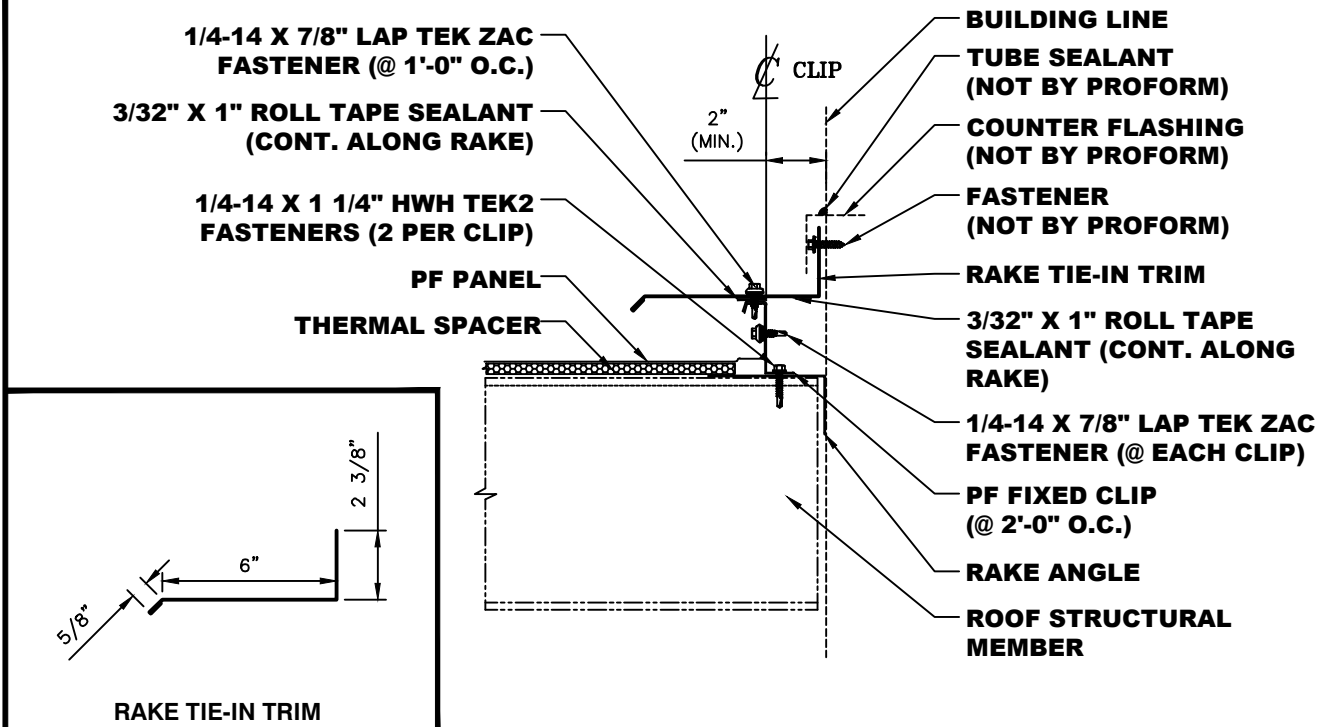

- NOTES:**
1. Rake Tie-In Trim to start even with building line.
 2. Place 3/32" x 1" Roll Tape Sealant along top of female leg of panel the length of the rake.
 3. Attach Rake Tie-In Trim with 1/4-14 x 7/8" Lap Tek ZAC fasteners at 1'-0" O.C. Place 3/32" x 3/8" Butyl Tape or 3/16" Ø bead of Butyl Tube Sealant in laps.
 4. Trim pieces lap 2".

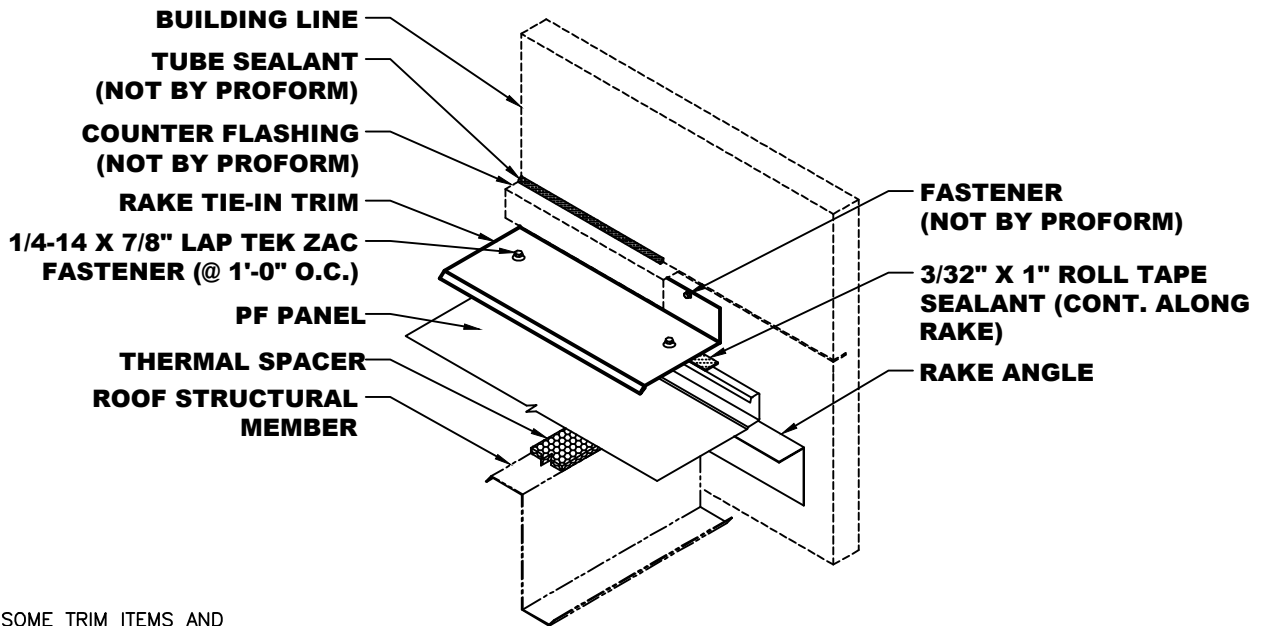

*NOTE: SOME TRIM ITEMS AND FASTENERS HAVE BEEN REMOVED FOR CLARITY OF ISOMETRIC DETAIL.

PF FLOATING RAKE END TIE-IN DETAIL

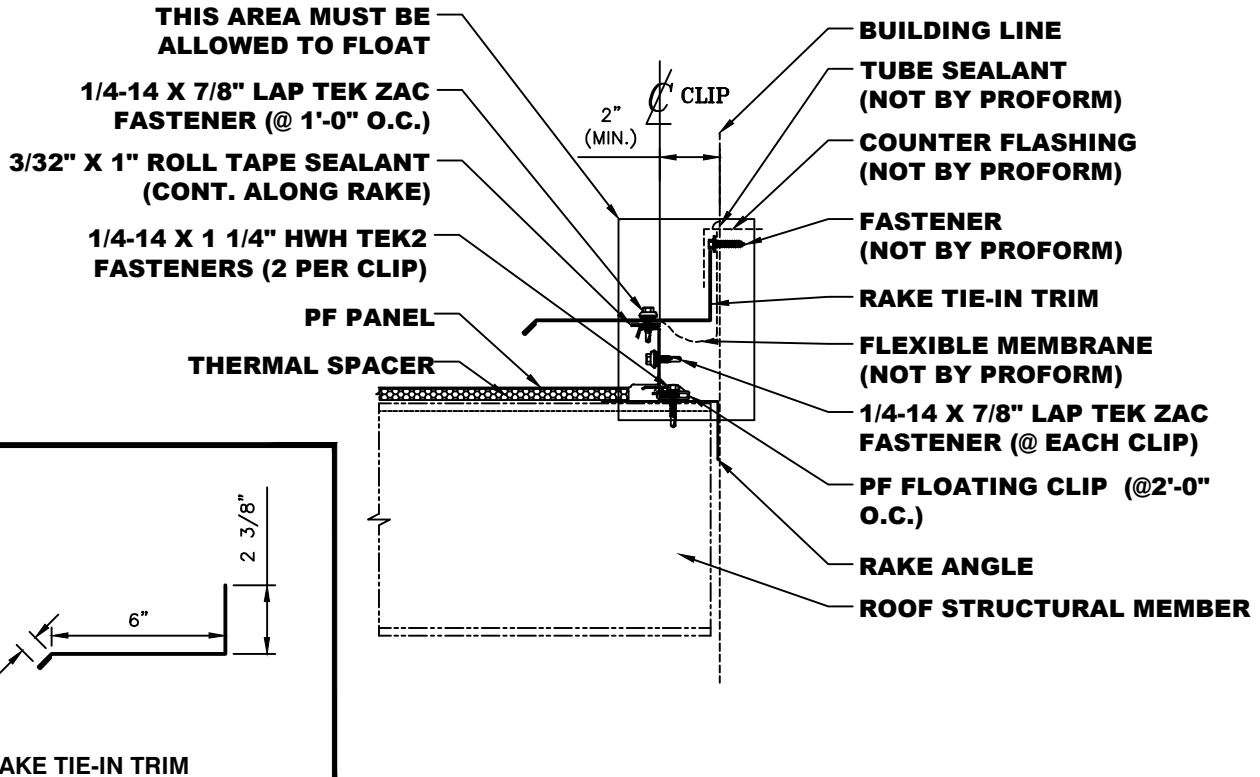

- NOTES:**
1. Rake Tie-In Trim to start even with building line.
 2. Place 3/32" x 1" Roll Tape Sealant along top of female leg of panel the length of the rake.
 3. Attach Rake Tie-In Trim with 1/4-14 x 7/8" Lap Tek ZAC fasteners at 1'-0" O.C. Place 3/32" x 3/8" Butyl Tape or 3/16" Ø bead of Butyl Tube Sealant in laps.
 4. Trim pieces lap 2".

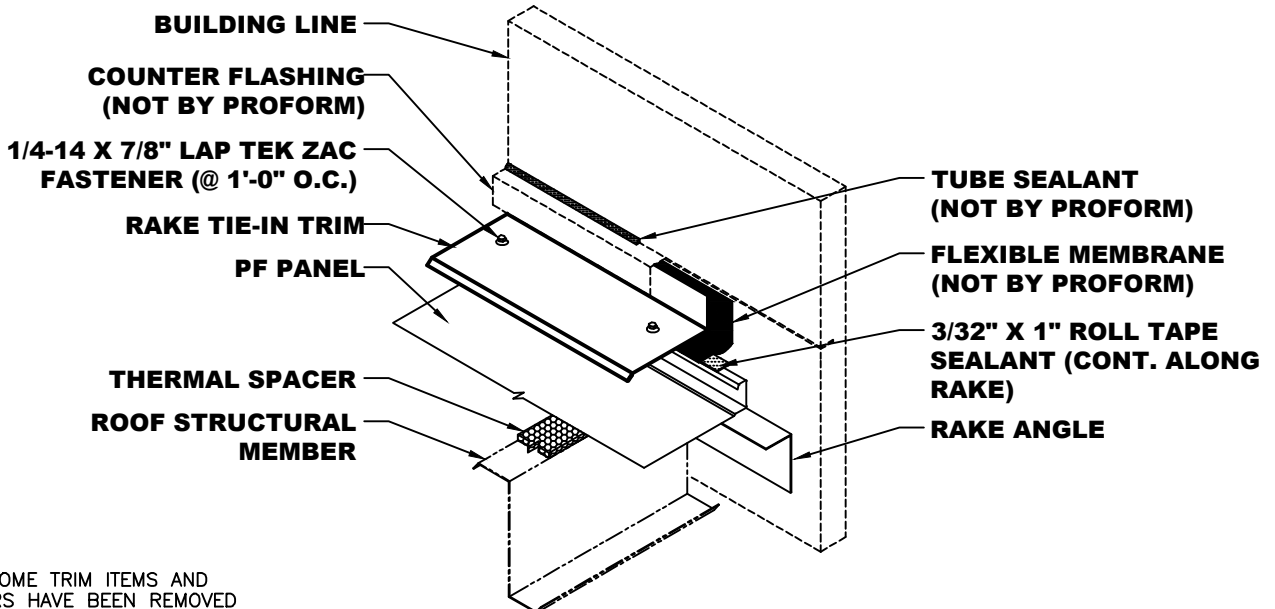

*NOTE: SOME TRIM ITEMS AND FASTENERS HAVE BEEN REMOVED FOR CLARITY OF ISOMETRIC DETAIL.

PF FIXED RAKE END TIE-IN DETAIL (OFF MODULE)

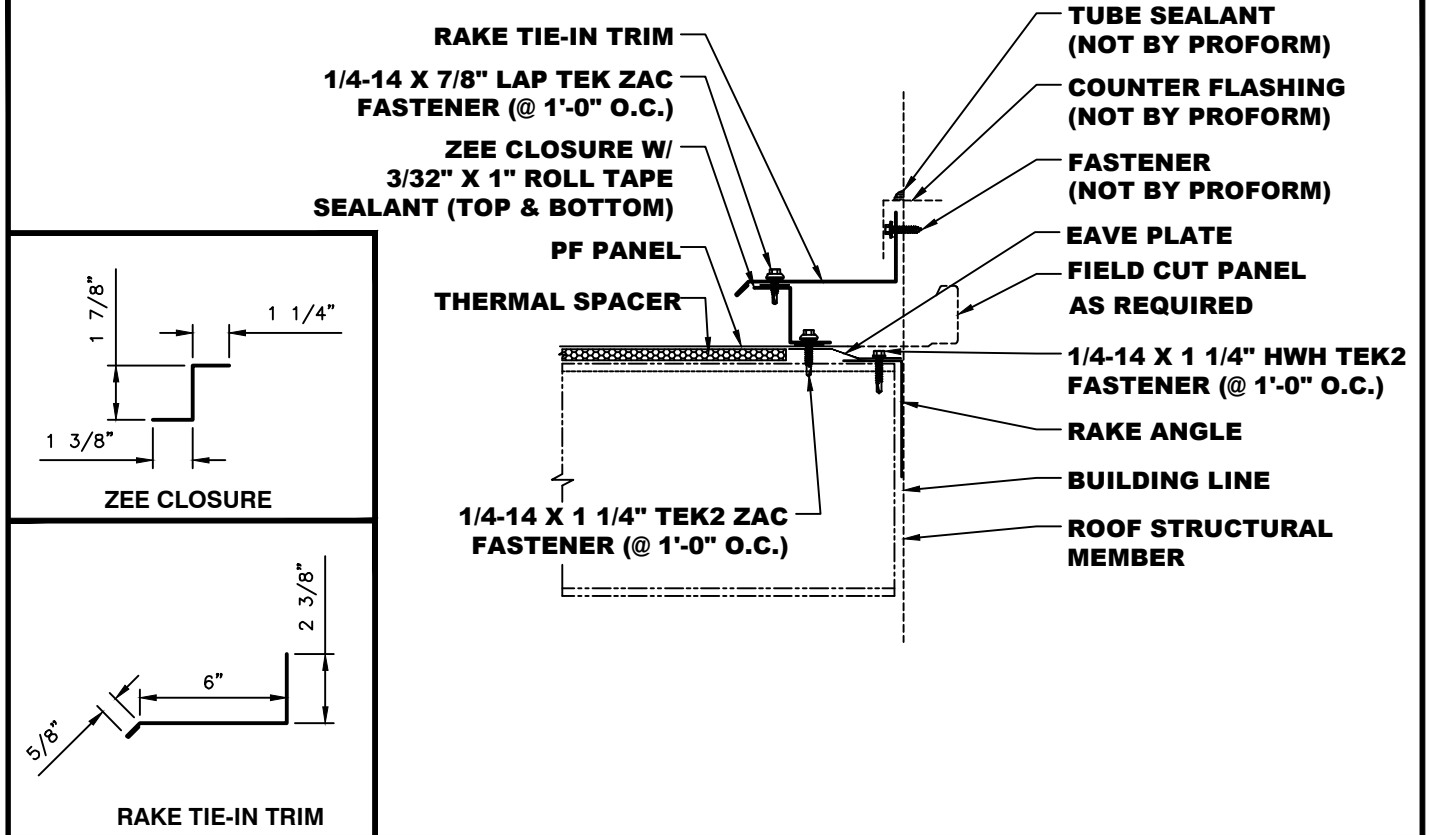

- NOTES:**
1. Rake Tie-In Trim to start even with building line.
 2. Place 3/32" x 1" Roll Tape Sealant on top and bottom of Zee Closure the length of the rake.
 3. Attach Zee Closure with 1/4-14 x 1 1/4" Lap Tek ZAC fasteners at 1'-0" O.C. Install from Ridge to Eave to avoid "Back Water Laps". Place 3/32" x 3/8" Butyl Tape or 3/16" Ø bead of Butyl Tube Sealant in laps.
 4. Attach Rake Tie-In Trim to Zee Closure with 1/4-14 x 7/8" Lap Tek ZAC fasteners at 1'-0" O.C.
 5. Trim pieces lap 2".

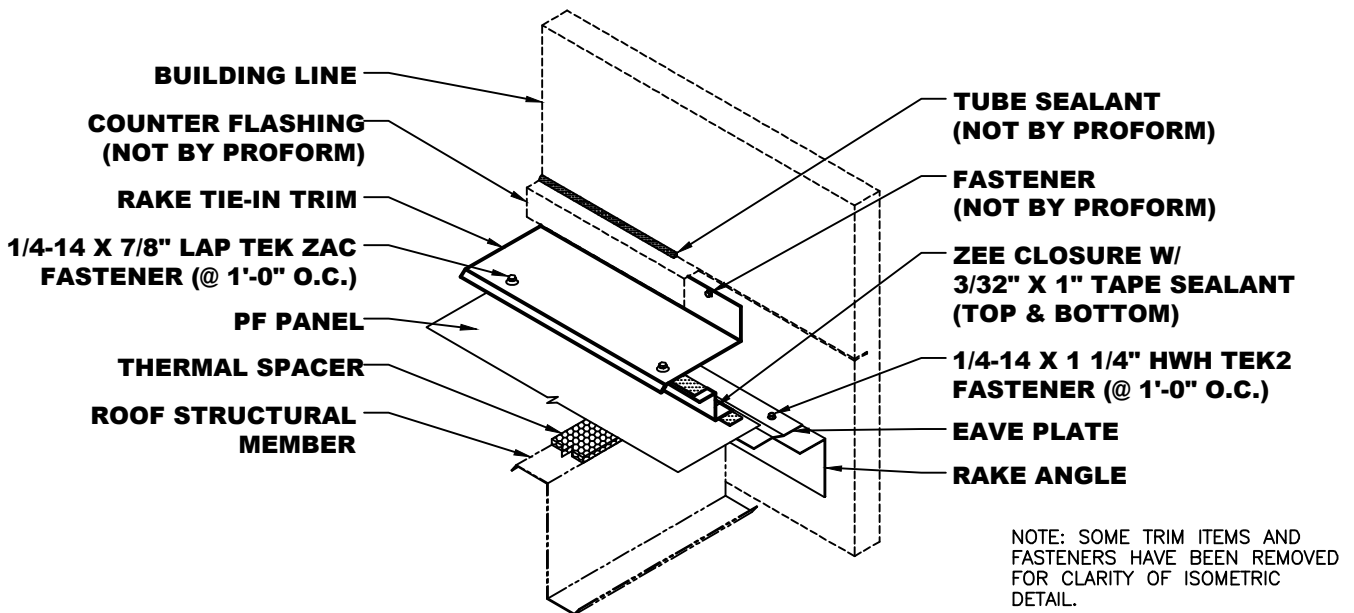

PF FLOATING RAKE END TIE-IN DETAIL (OFF MODULE)

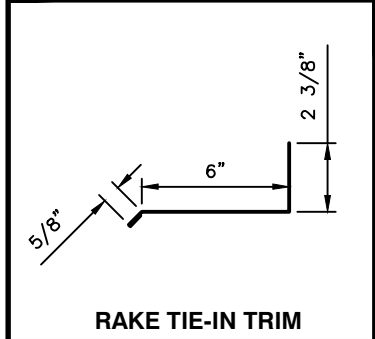
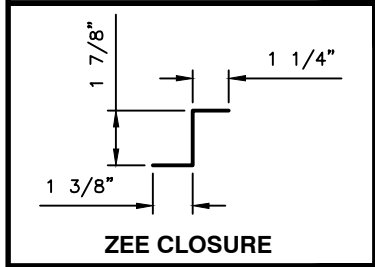
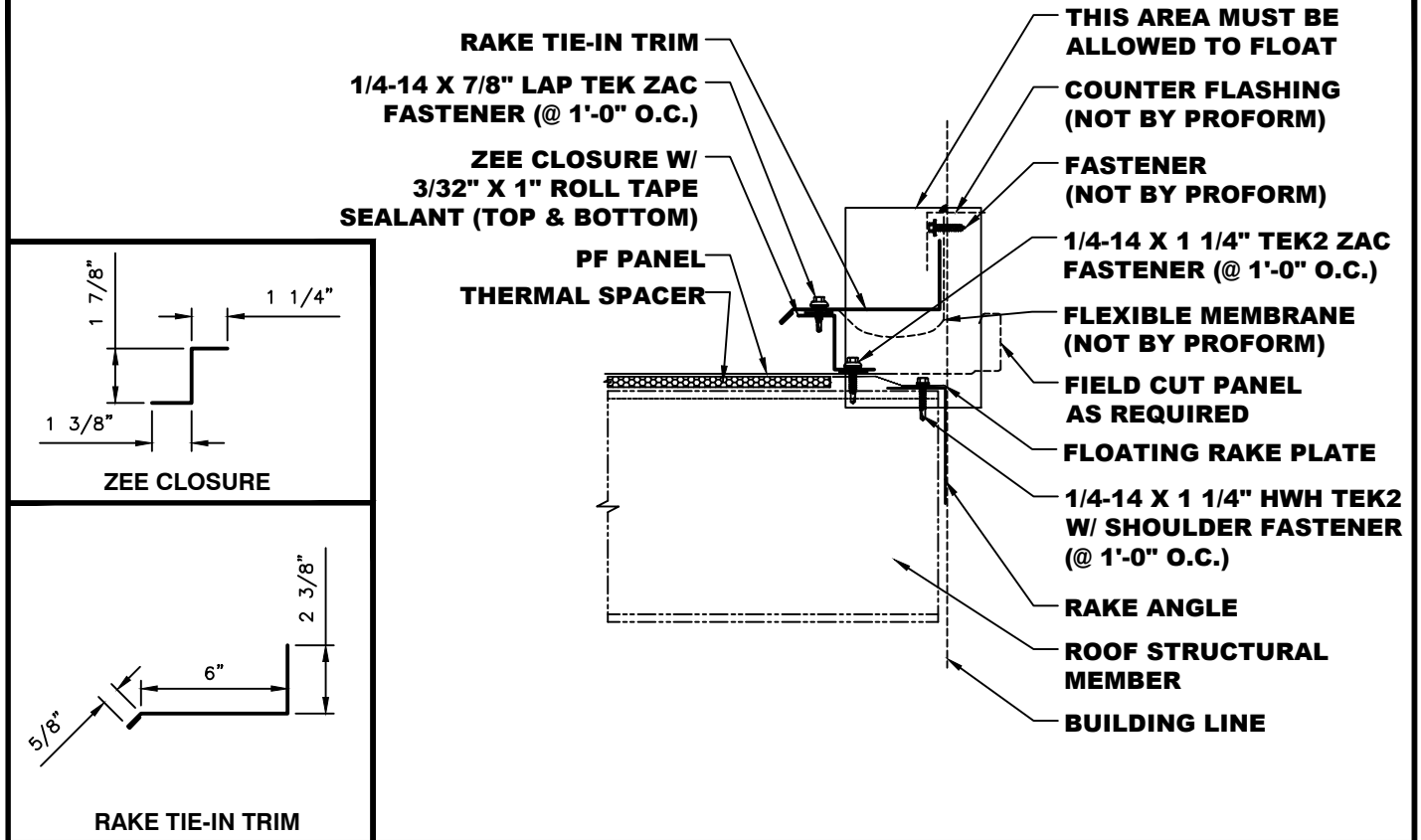

- NOTES:**
1. Rake Tie-In Trim to start even with building line.
 2. Place 3/32" x 1" Roll Tape Sealant on top and bottom of Zee Closure the length of the rake.
 3. Attach Zee Closure with 1/4-14 x 1 1/4" Lap Tek ZAC fasteners at 1'-0" O.C. Install from Ridge to Eave to avoid "Back Water Laps". Place 3/32" x 3/8" Butyl Tape or 3/16" Ø bead of Butyl Tube Sealant in laps.
 4. Attach Rake Tie-In Trim to Zee Closure with 1/4-14 x 7/8" Lap Tek ZAC fasteners at 1'-0" O.C.
 5. Trim pieces lap 2".

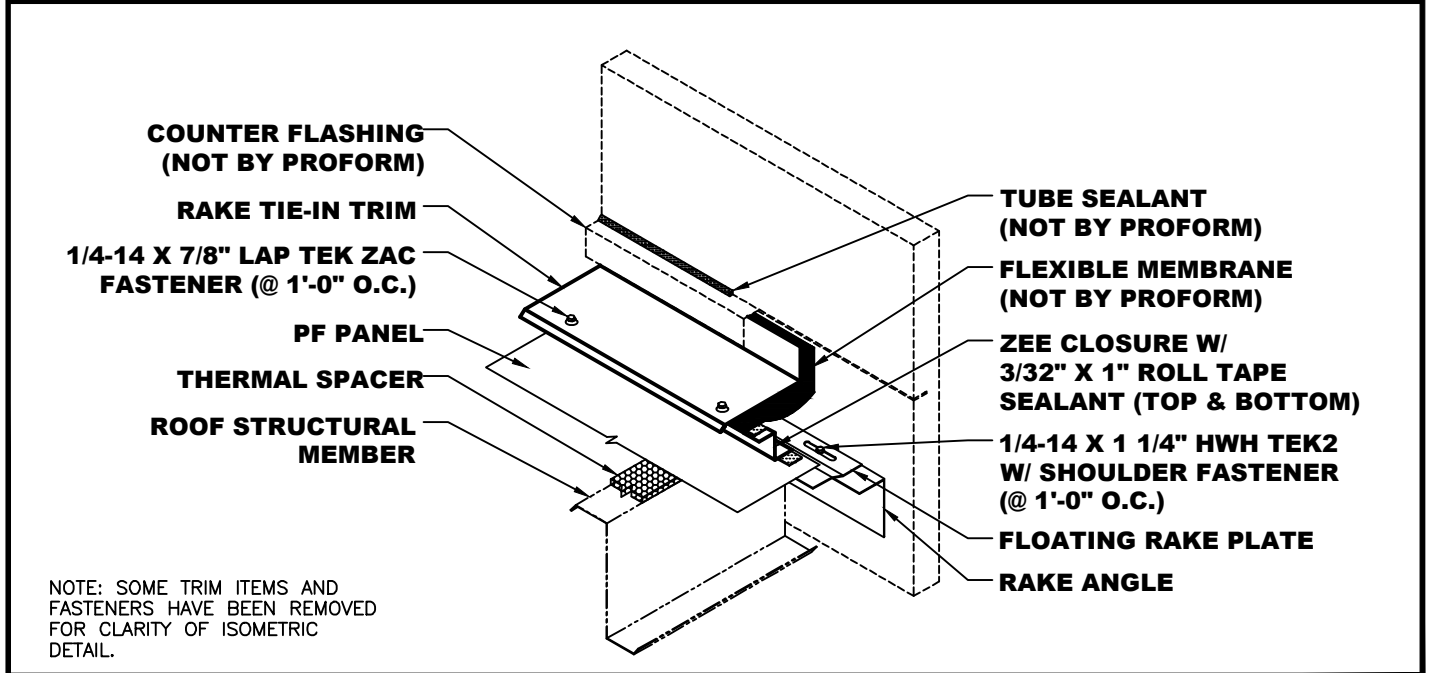

NOTE: SOME TRIM ITEMS AND FASTENERS HAVE BEEN REMOVED FOR CLARITY OF ISOMETRIC DETAIL.

PF VALLEY DETAIL

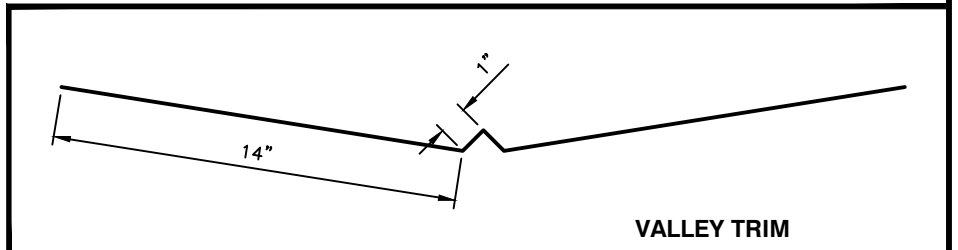
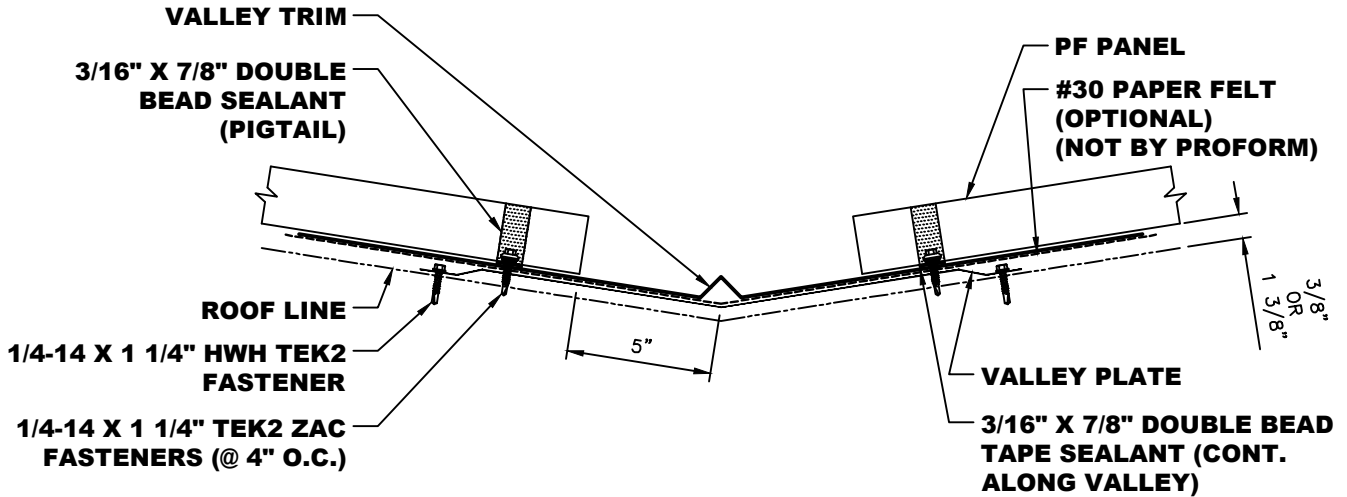

- NOTES:**
1. Install Valley Trim from eave to ridge. Valley Trim pieces lap 6". Place 3/32" x 1" Butyl Tape or a 3/16" Ø bead of Butyl Tube Sealant in laps.
 2. Cut panels at required bevel for valley condition.
 3. Apply a continuous line of 3/16" x 7/8" Double Bead Tape Sealant up both sides of Valley Trim.
 4. Install roof panels and attach with 1/4-14 x 1 1/4" Tek2 ZAC fasteners at 4" O.C.

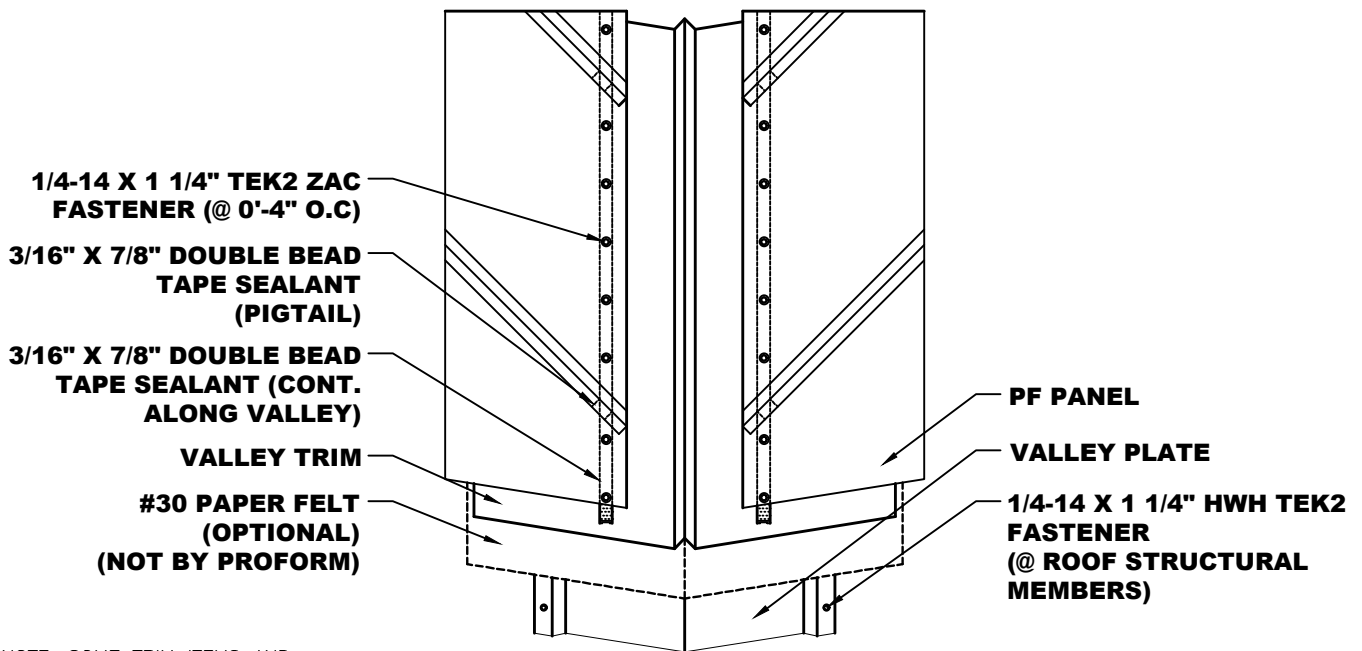

NOTE: SOME TRIM ITEMS AND FASTENERS HAVE BEEN REMOVED FOR CLARITY OF ISOMETRIC DETAIL.

PF FIXED HIGH SIDE TIE-IN DETAIL

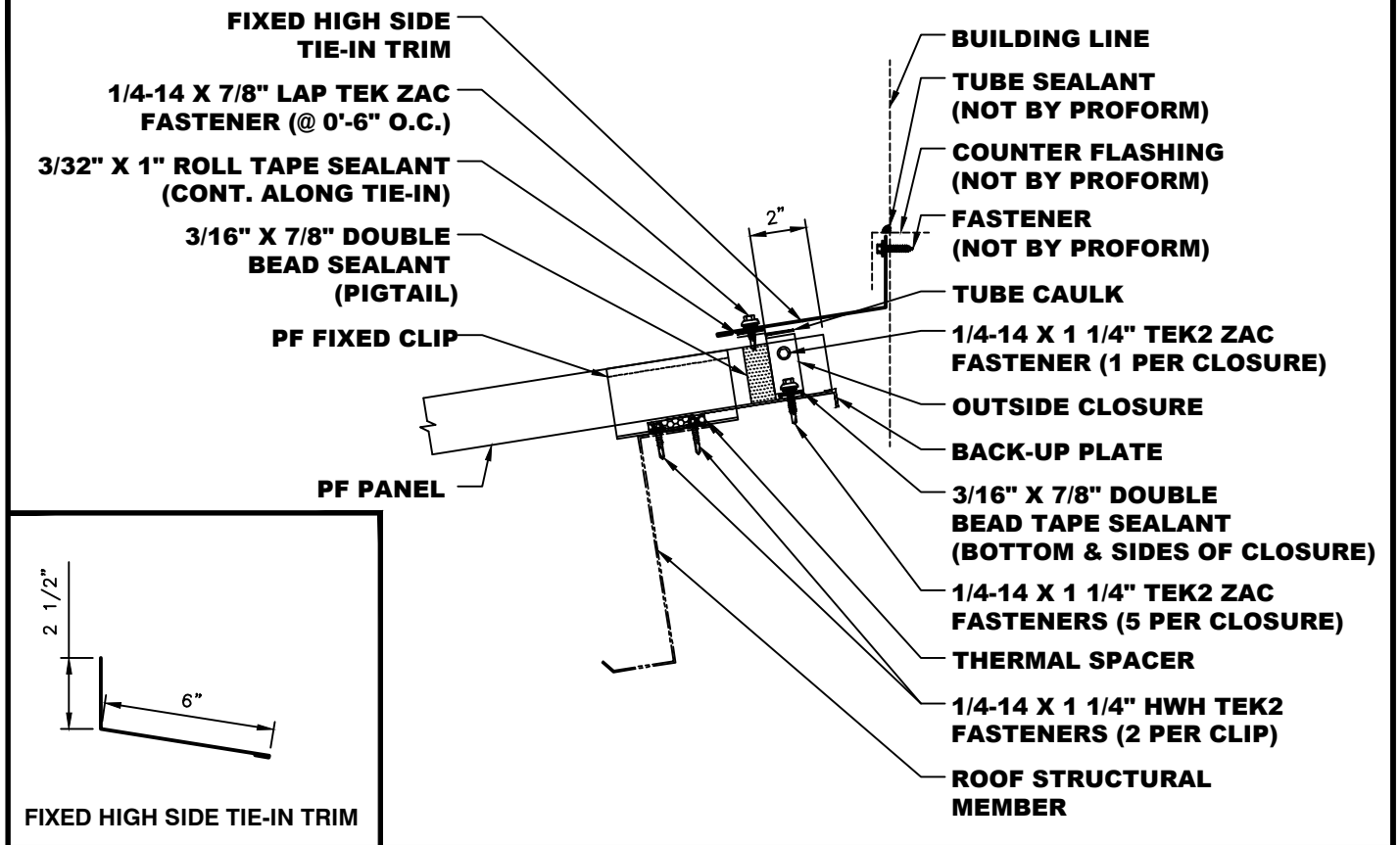

- NOTES:**
1. Install High Side Tie-In Trim from out of panel to out of panel.
 2. Apply continuous line of 3/32" x 1" Roll Tape Sealant along top of Outside Closures.
 3. Install High Side Tie-In Trim to Outside Closures with 1/4-14 x 7/8" Lap Tek Zac Fasteners at 6" O.C.
 4. Trim laps are 2". Apply 3/32" x 1" Butyl Tape or a 3/16" Ø bead of Tube Butyl in laps.

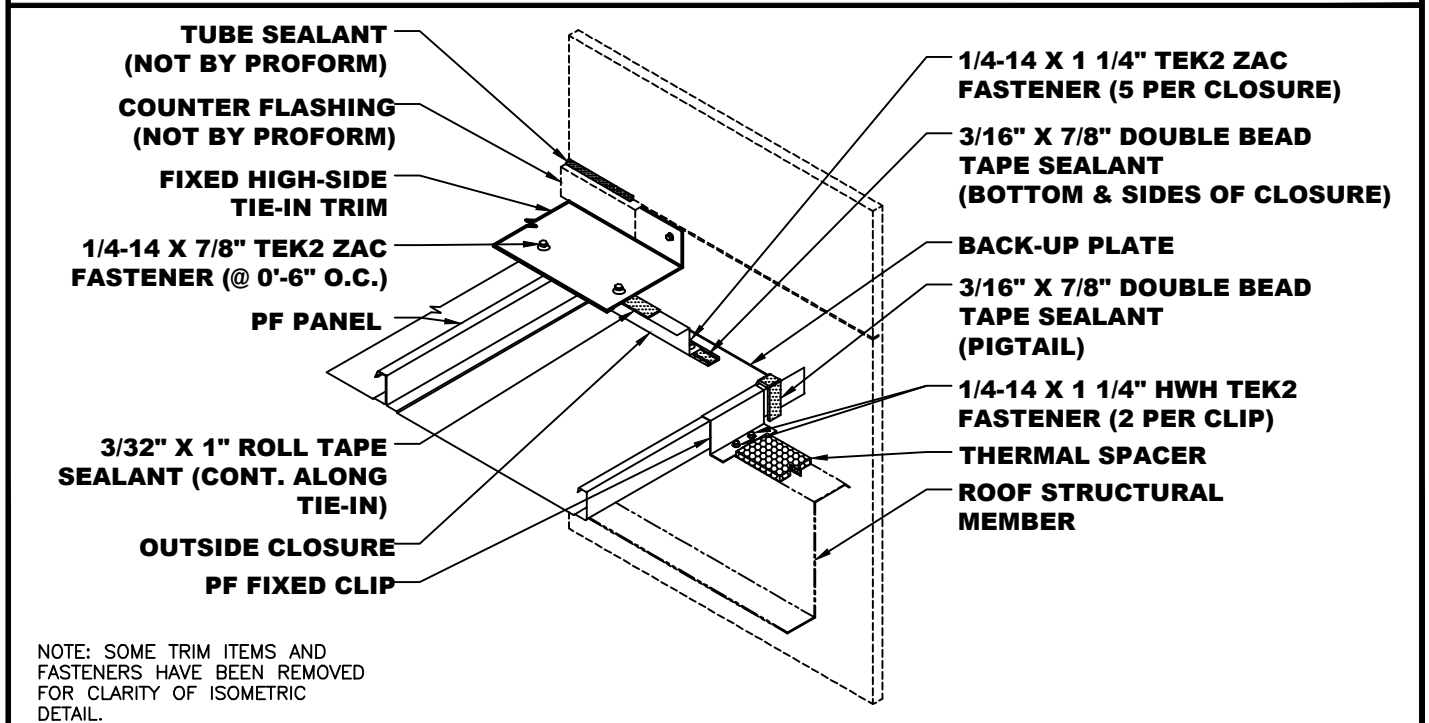

NOTE: SOME TRIM ITEMS AND FASTENERS HAVE BEEN REMOVED FOR CLARITY OF ISOMETRIC DETAIL.

PF FLOATING HIGH SIDE TIE-IN DETAIL

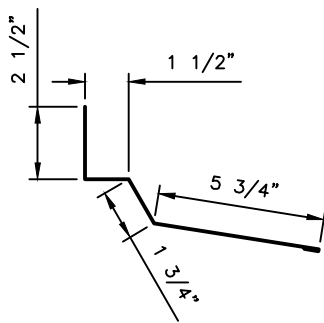
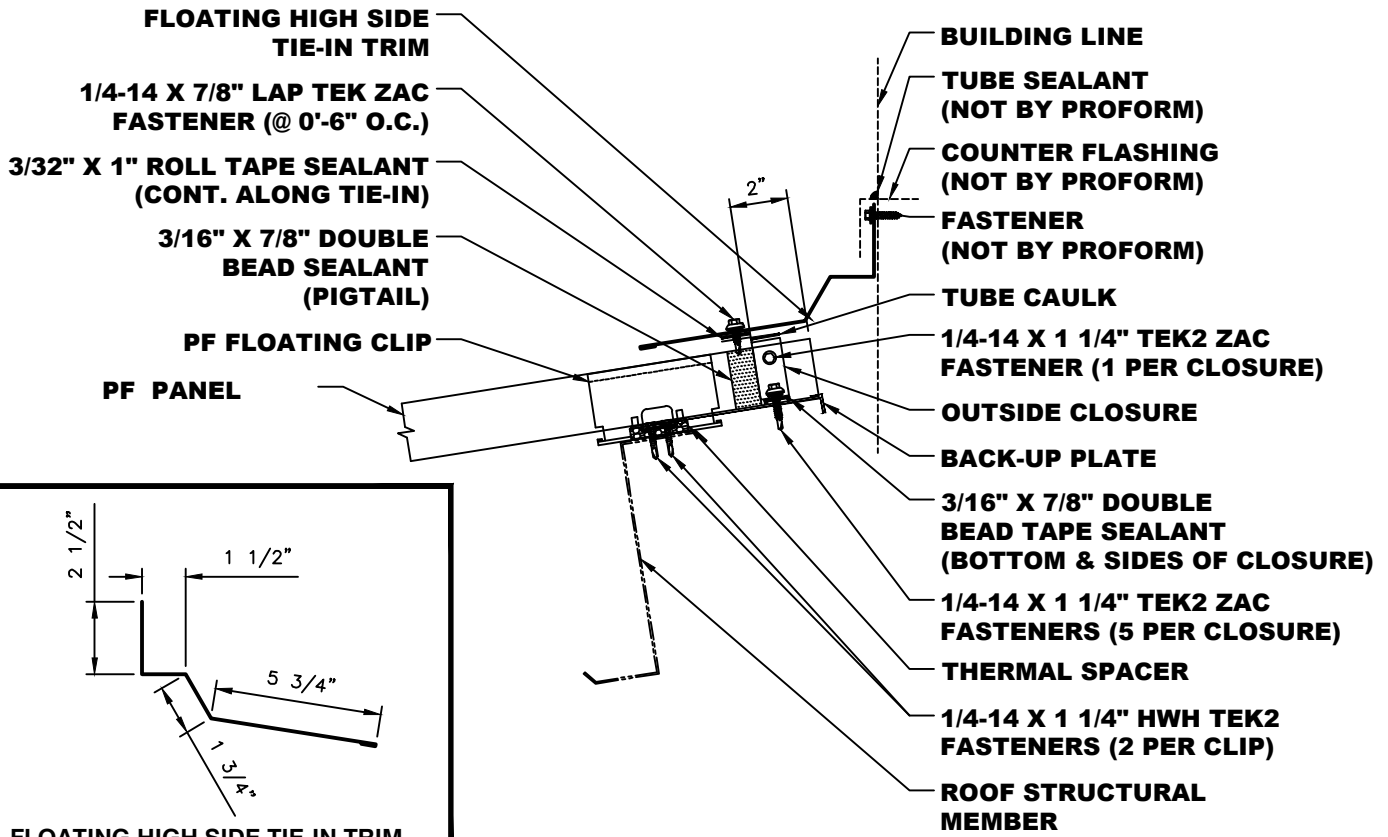

- NOTES:**
1. Install High Side Tie-In Trim from out of panel to out of panel.
 2. Apply continuous line of 3/32" x 1" Roll Tape Sealant along top of Outside Closures.
 3. Install High Side Tie-In Trim to Outside Closures with 1/4-14 x 7/8" Lap Tek Zac Fasteners at 6" O.C.
 4. Trim laps are 2". Apply 3/32" x 1" Butyl Tape or a 3/16" Ø bead of Tube Butyl in laps.

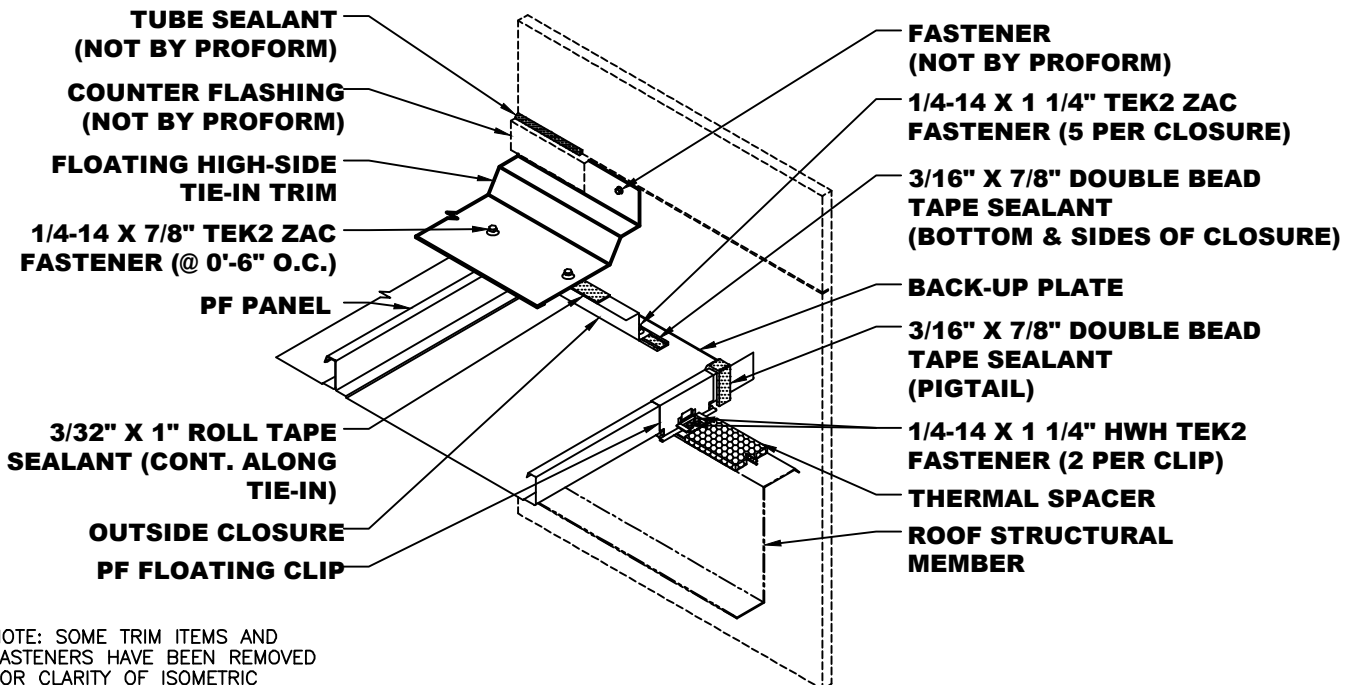

NOTE: SOME TRIM ITEMS AND FASTENERS HAVE BEEN REMOVED FOR CLARITY OF ISOMETRIC

PF END LAP DETAIL

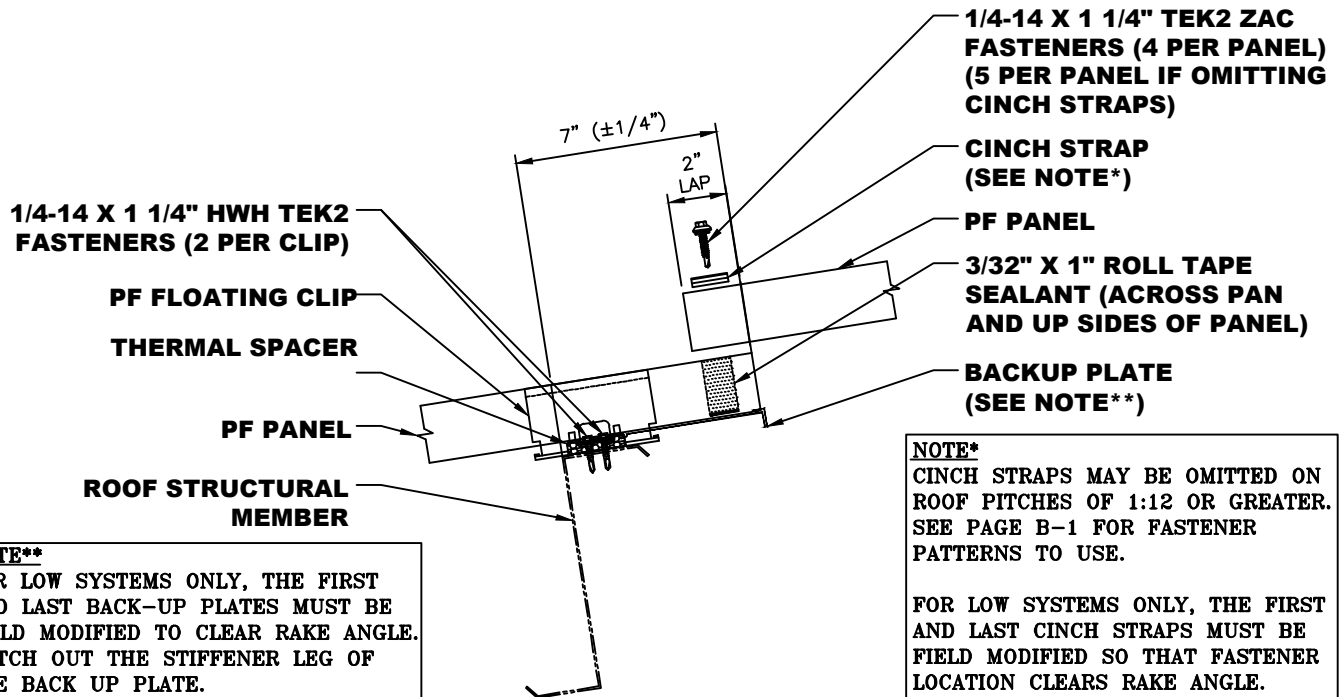

- NOTES:**
1. Prior to attaching panel to the Eave Plate, measure the panel overhang at the purlin. The panel should extend 7" (+/- 1/4") up slope from the web of the purlin or centerline of joist.
 2. Slide the Back-up Plate on the end of the panel. Make sure the teeth are fully engaged with the panel.
 3. Apply a line of 3/32" x 1" Roll Tape Sealant 1 3/4" from the up slope end of the panel. The factory notches along the leading and trailing legs are 2" long and can be used as a guide to start the sealant placement.
 4. Position the up slope panel so the hook portion of the trailing leg is against the notch portion of the previously installed panel. The up slope panel should be aligned so the tape sealant on the down slope panel is covered by the up slope panel.

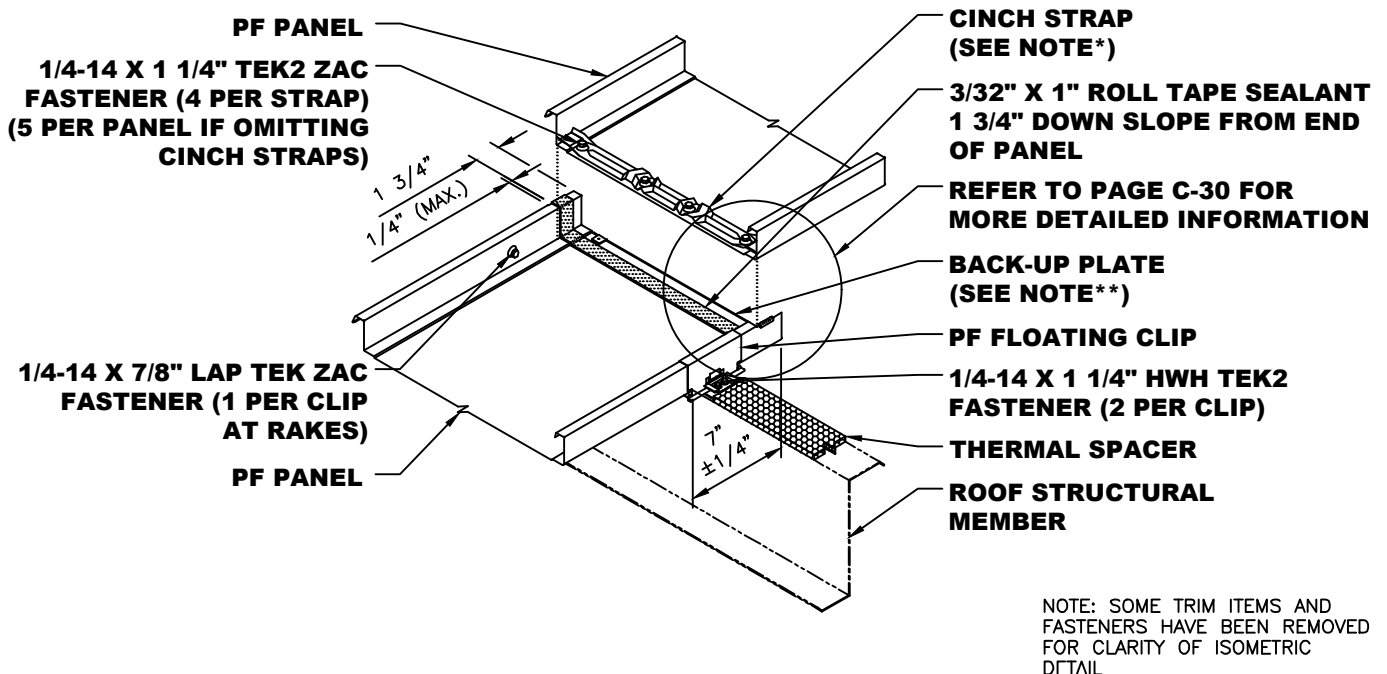

PF END LAP DETAIL (CONT.)

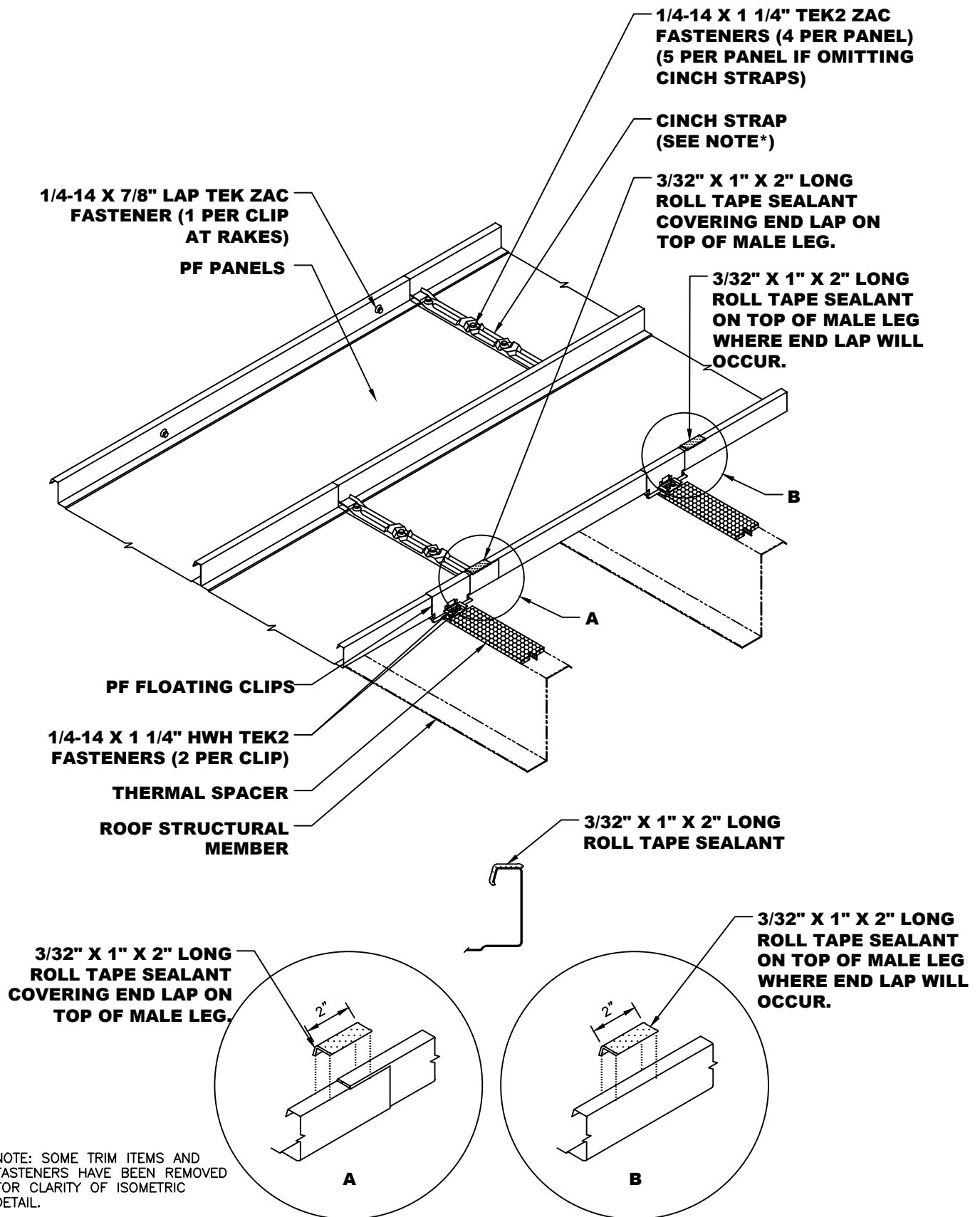

PF OUTSIDE CLOSURE INSTALLATION DETAIL

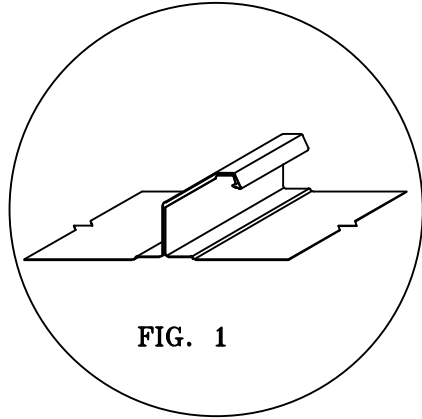
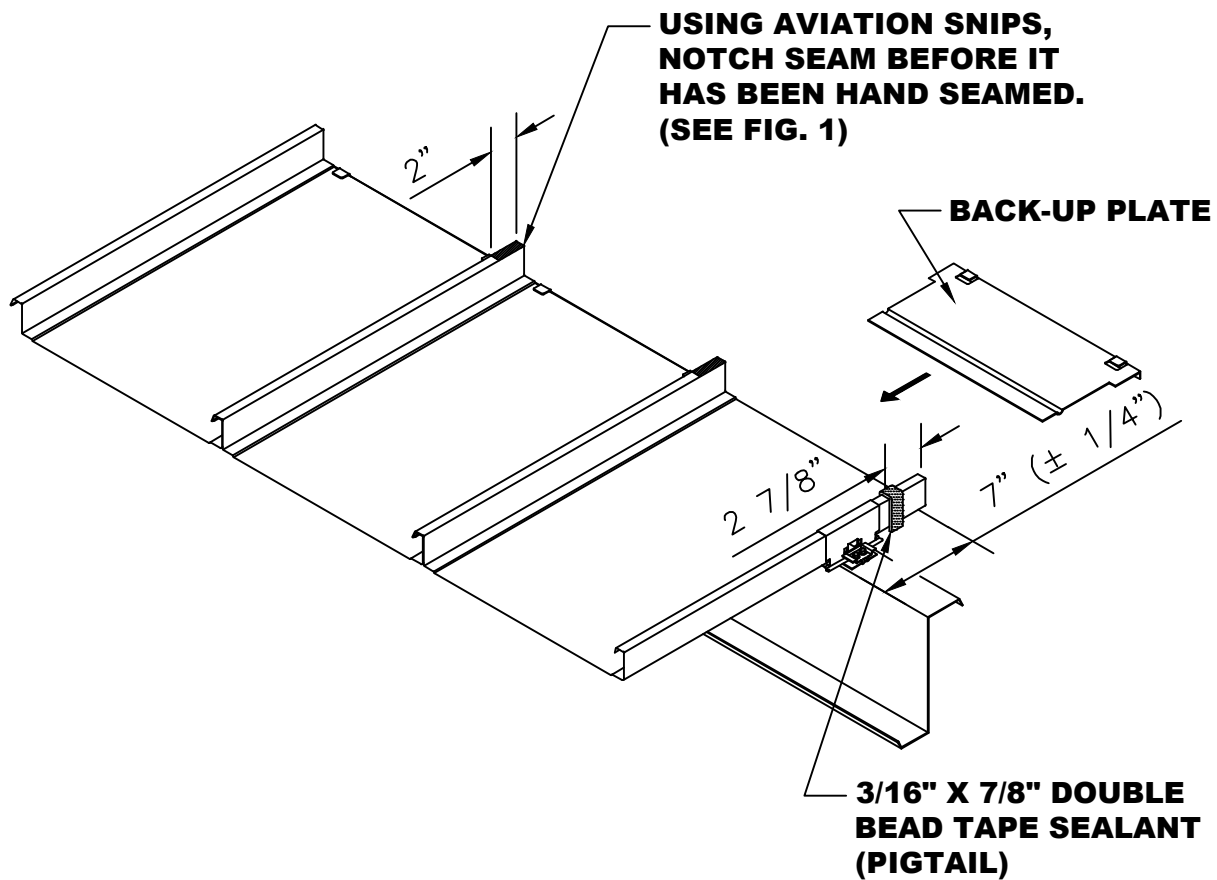

FIG. 1



STEP 1

NOTE: SOME TRIM ITEMS AND FASTENERS HAVE BEEN REMOVED FOR CLARITY OF ISOMETRIC DETAIL.

INSTALL PANELS AND BACK-UP PLATES AS NORMAL. NOTCH PANELS SEAMS AT RIDGE TWO INCHES (2") DOWN FROM END OF PANEL, REMOVING ALL OF THE HORIZONTAL PORTION OF THE SEAM. SEE FIGURE 1.

PF OUTSIDE CLOSURE INSTALLATION DETAIL

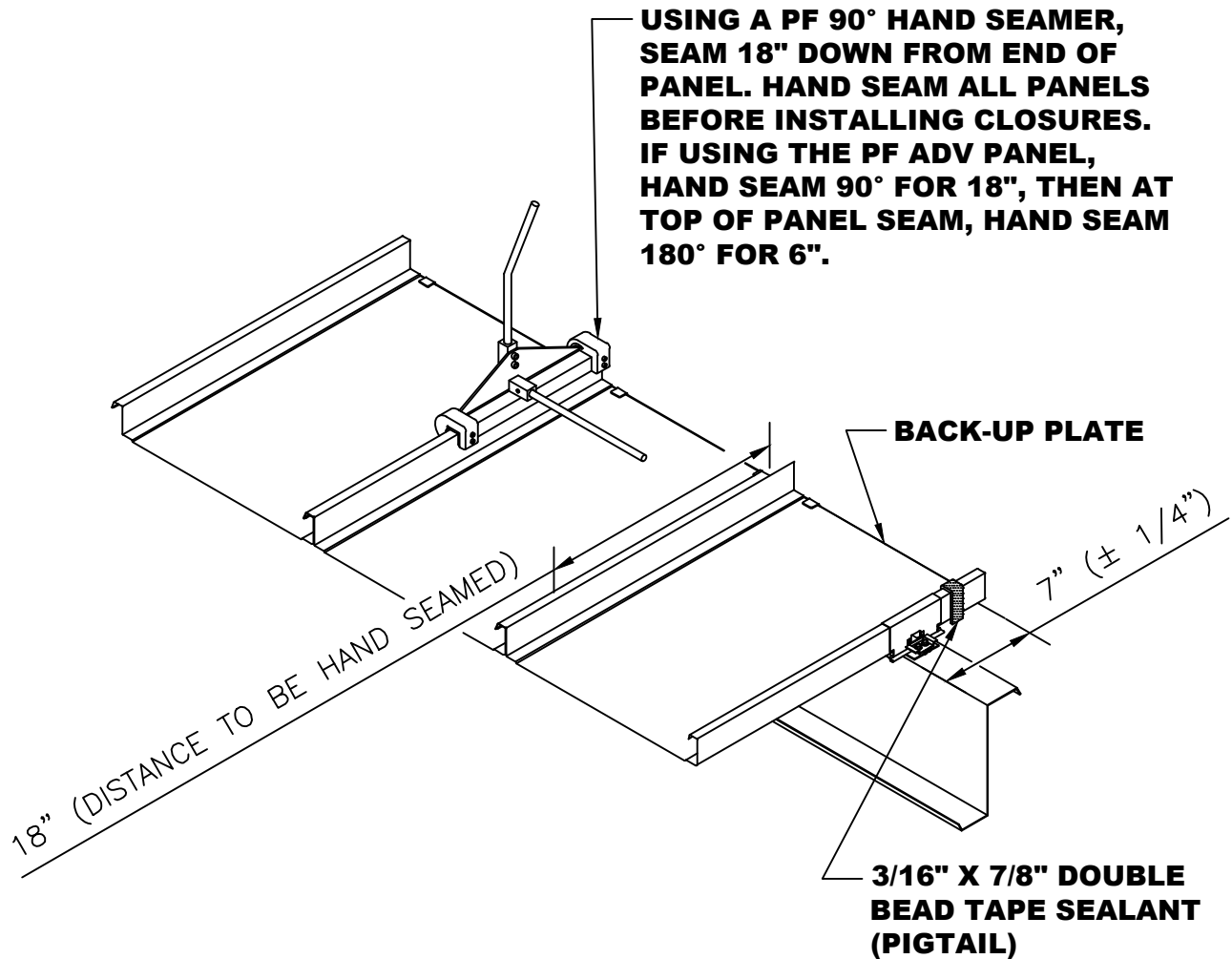

NOTE: SOME TRIM ITEMS AND FASTENERS HAVE BEEN REMOVED FOR CLARITY OF ISOMETRIC DETAIL.

STEP 2

HAND SEAM PANELS EIGHTEEN INCHES (18") DOWN FROM THE ENDS OF THE PANELS.

PF OUTSIDE CLOSURE INSTALLATION DETAIL

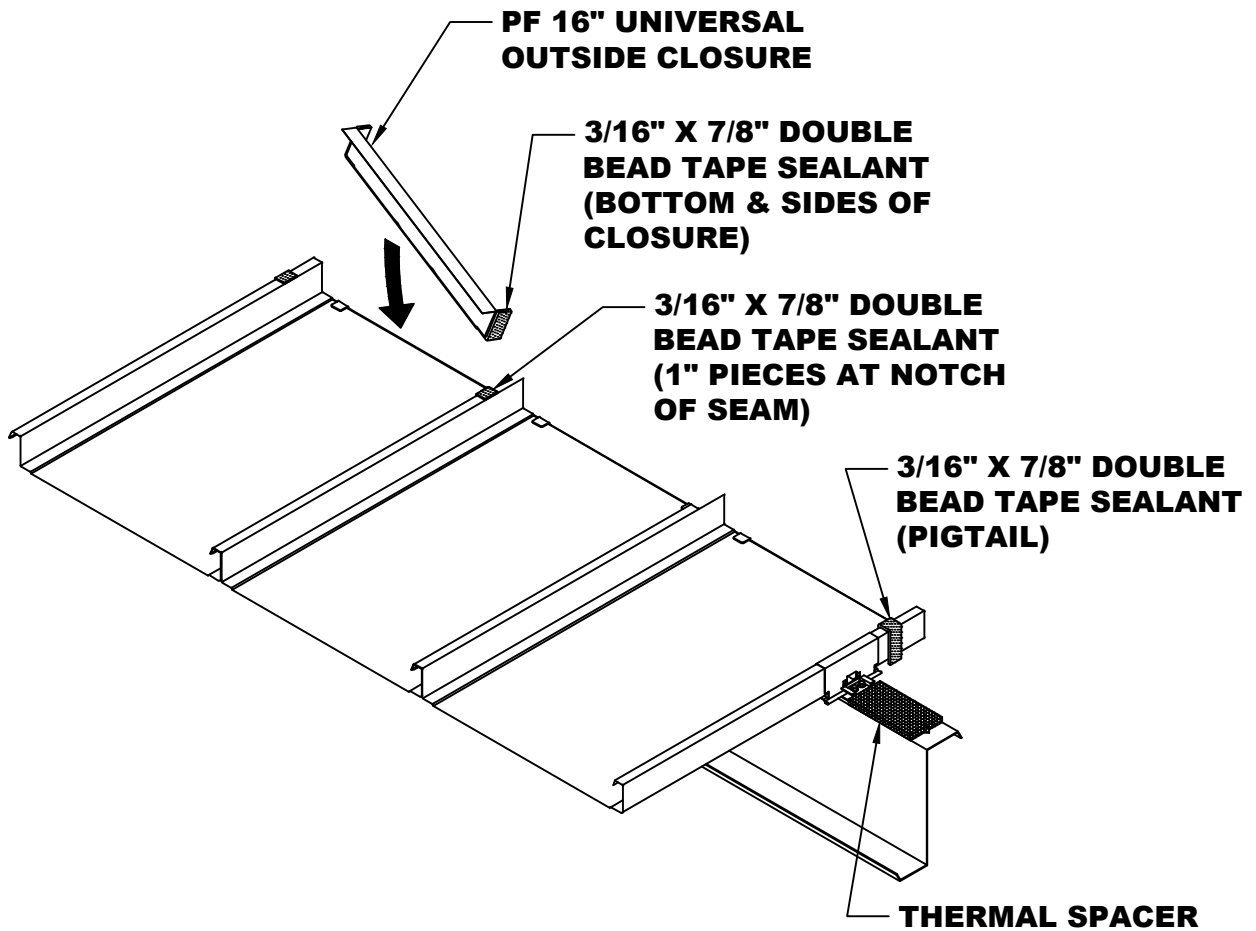

STEP 3

APPLY 3/16" X 7/8" ROLL TAPE SEALANT TO THE TOP SIDE OF THE PANEL SEAM WHERE THE NOTCH YOU MADE ENDS.

APPLY 3/16" X 7/8" DOUBLE BEAD TAPE SEALANT TO THE BOTTOM AND SIDES OF THE OUTSIDE CLOSURE. (THIS SEALANT MUST BE CONTINUOUS FROM ONE SIDE TO THE OTHER)

INSTALL OUTSIDE CLOSURES SO THAT VERTICAL FACE OF CLOSURE IS LINED UP AT NOTCH IN SEAM.

NOTE: SOME TRIM ITEMS AND FASTENERS HAVE BEEN REMOVED FOR CLARITY OF ISOMETRIC DETAIL.

PF OUTSIDE CLOSURE INSTALLATION DETAIL

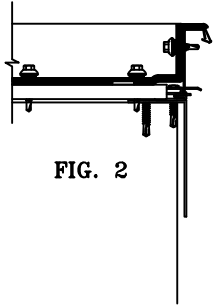
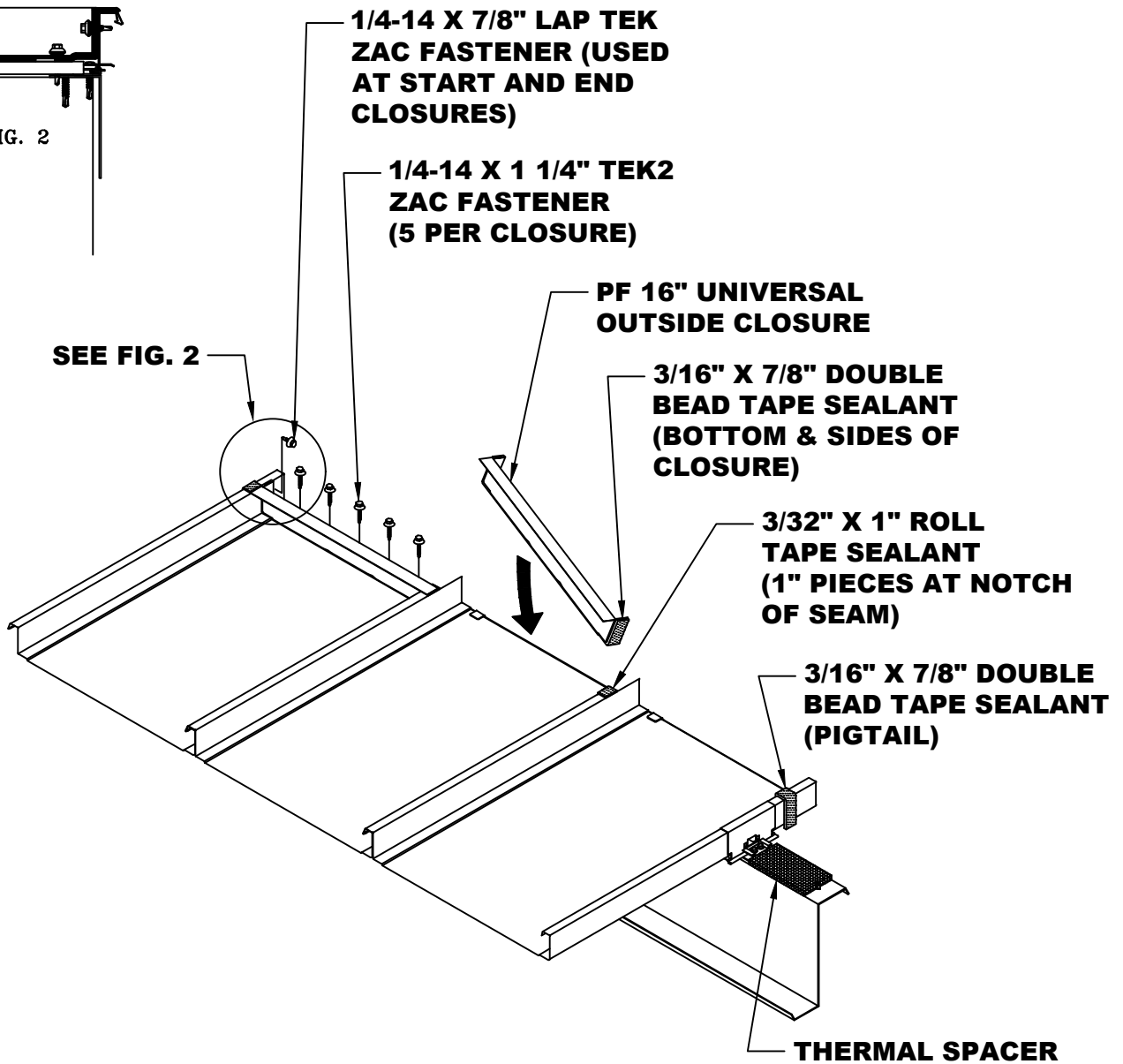

FIG. 2



STEP 4

FASTEN OUTSIDE CLOSURES TO PANELS WITH FIVE (5) 1/4-14 X 1 1/4" TEK2 ZAC FASTENERS.

AT THE STARTING AND ENDING PANELS ONLY, USE ONE (1) 1/4-14 X 7/8" LAP TEK ZAC FASTENER TO SECURE THE OUTSIDE VERTICAL LEG OF THE CLOSURE TO THE VERTICAL LEG OF THE PANEL. SEE FIG. 2.

NOTE: SOME TRIM ITEMS AND FASTENERS HAVE BEEN REMOVED FOR CLARITY OF ISOMETRIC DETAIL.

PF OUTSIDE CLOSURE INSTALLATION DETAIL

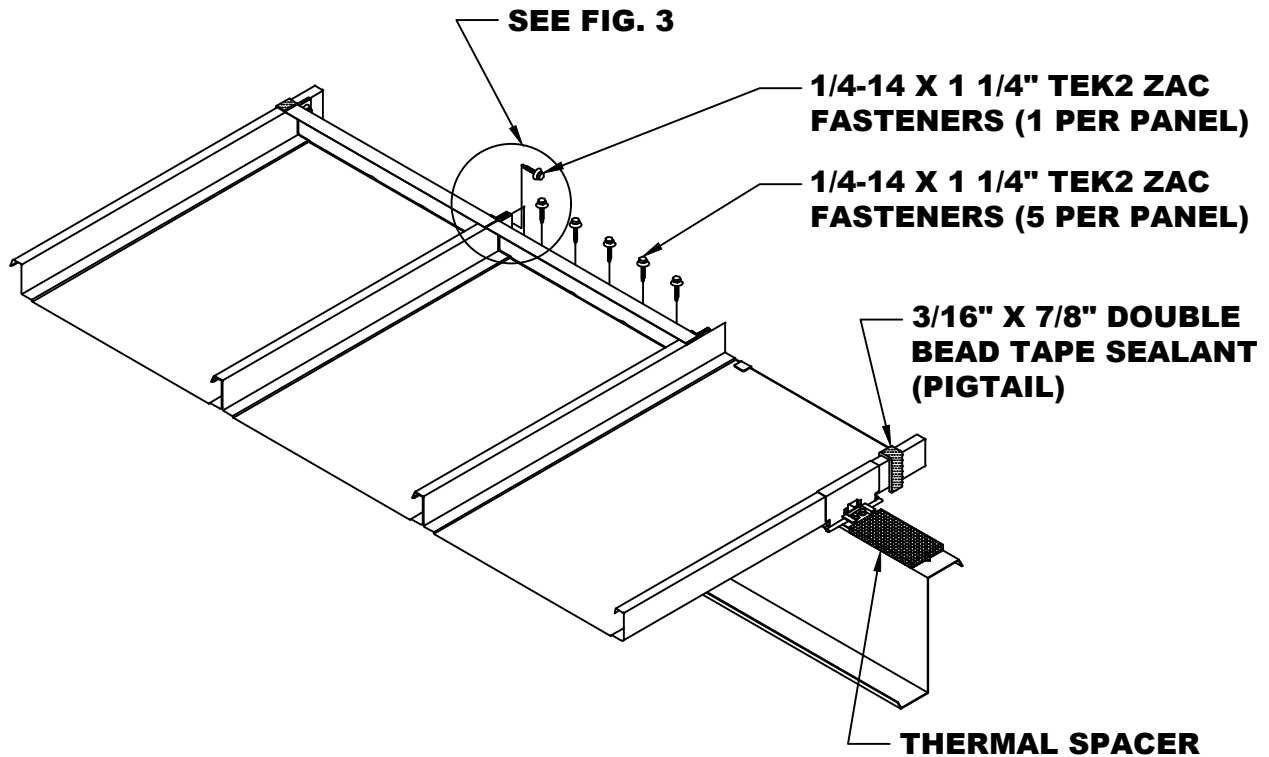

STEP 5

FASTEN OUTSIDE CLOSURES TO PANELS AS DESCRIBED
IN STEP 4.

SECURE THE VERTICAL LEG OF THE CLOSURES TO THE
VERTICAL SEAM WITH ONE (1) 1/4-14 X 1 1/4" TEK2
ZAC FASTENER. SEE FIGURE 3.

NOTE: SOME TRIM ITEMS AND
FASTENERS HAVE BEEN REMOVED
FOR CLARITY OF ISOMETRIC
DETAIL

PF OUTSIDE CLOSURE INSTALLATION DETAIL

OUTSIDE CLOSURE

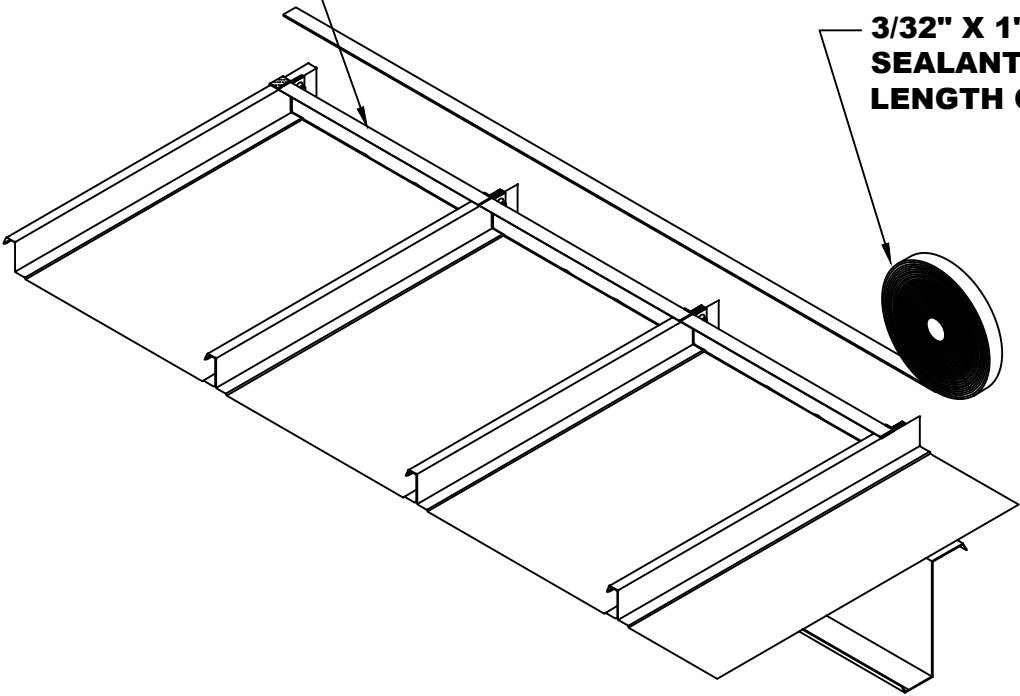

3/32" X 1" ROLL TAPE SEALANT (CONT. ALONG LENGTH OF RIDGE)

STEP 6

NOTE: SOME TRIM ITEMS AND FASTENERS HAVE BEEN REMOVED FOR CLARITY OF ISOMETRIC DFTAIL.

APPLY 3/32" X 1" ROLL TAPE SEALANT TO THE TOP OF THE OUTSIDE CLOSURES. THIS TAPE IS CONTINUOUS ALONG THE FULL LENGTH OF THE RIDGE, HIGH SIDE EAVE, HI-SIDE TIE-IN, HIP, TRANSITION, ETC.

PF 3" OUTSIDE CLOSURE INSTALLATION DETAIL

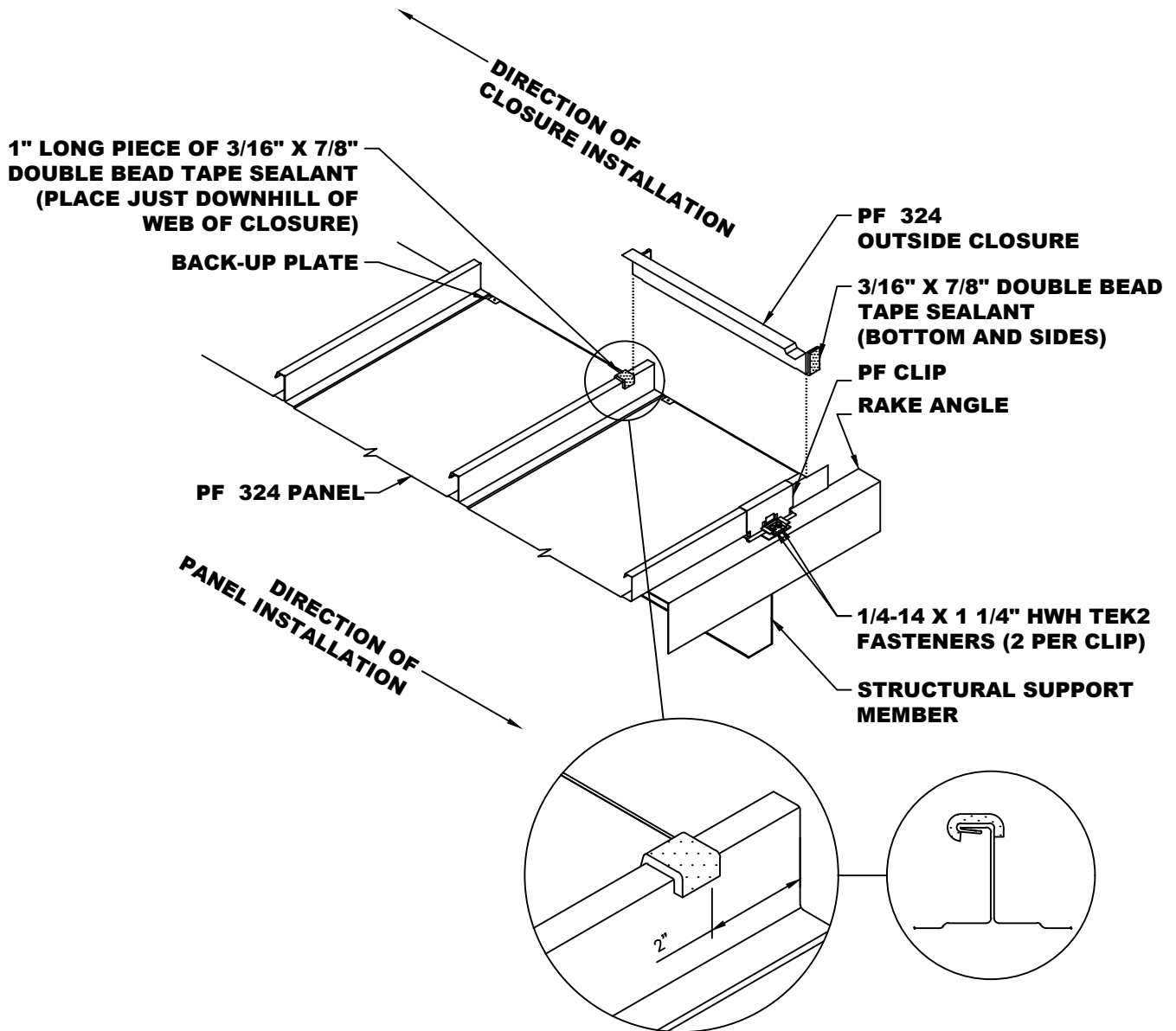

NOTE: SOME TRIM ITEMS AND FASTENERS HAVE BEEN REMOVED FOR CLARITY OF ISOMETRIC DETAIL.

- NOTES:**
1. Starting from the right hand side of roof, hand crimp seams 18" down from the end of the panel.
 2. Place a 1" long piece of 3/16" x 7/8" Double Bead Tape Sealant across the top of the seam at the notch. If panels are not factory notched, place sealant tape 2" down from end of seam.
 3. Apply 3/16" x 7/8" Double Bead Tape Sealant to the sides and bottom of an Outside Closure.
 4. Starting at the right-hand side of the roof, install Outside Closures and fasten to the pan of the roof panels with five (5) 1/4-14 x 1 1/4" Tek2 ZAC Fasteners and one (1) 1/4-14 x 1 1/4" Tek2 ZAC Fastener through the tabs into the panel seams.

PF DEKTITE DETAIL

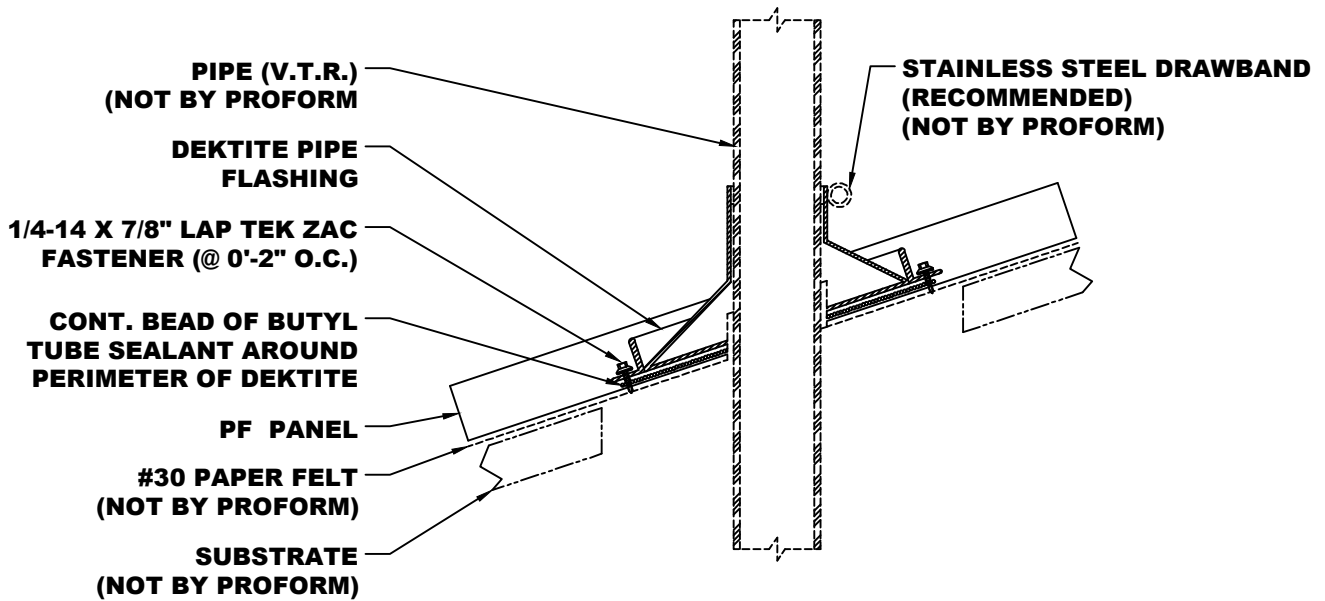

- NOTES:**
1. Cut hole in panel 1" larger than pipe diameter. If installing over a solid substrate, over-cut hole in substrate so fastener do not pin system from thermal movement.
 2. Cut hole in top of Dektite Boot so that it fits snugly around pipe. Apply a 3/16" Ø bead of Tube Butyl sealant around the base flange of boot. Secure to panel with 1/4-14 x 7/8" Lap Tek ZAC fasteners 2" O.C.
 3. Dektite boot MUST fit in pan of panel. Do not fasten to standing seams.

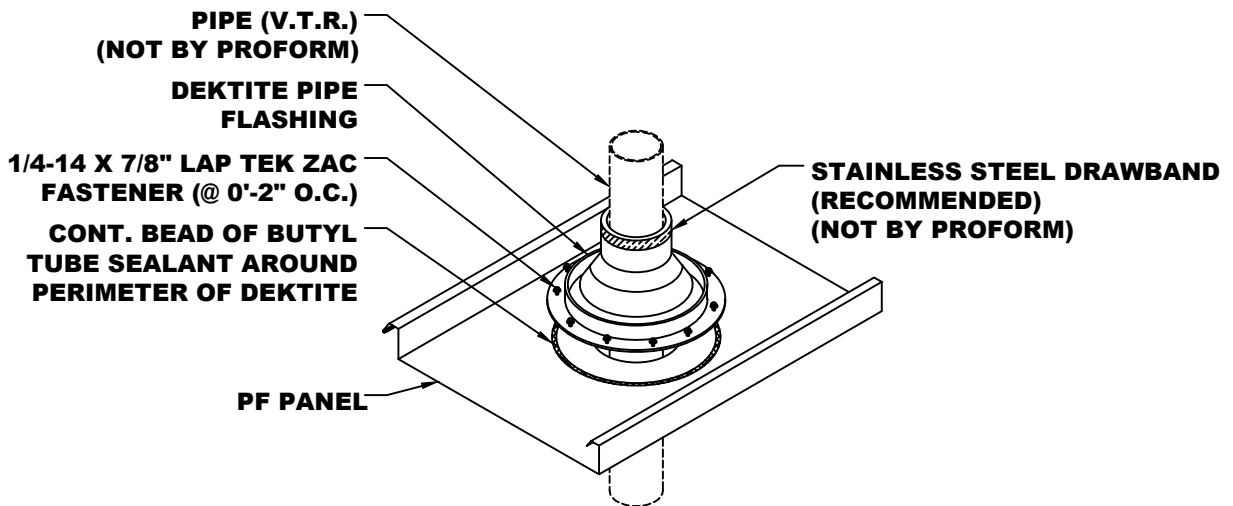

NOTE: SOME TRIM ITEMS AND FASTENERS HAVE BEEN REMOVED FOR CLARITY OF ISOMETRIC DETAIL

PF ALTERNATE DEKTITE INSTALLATION DETAIL

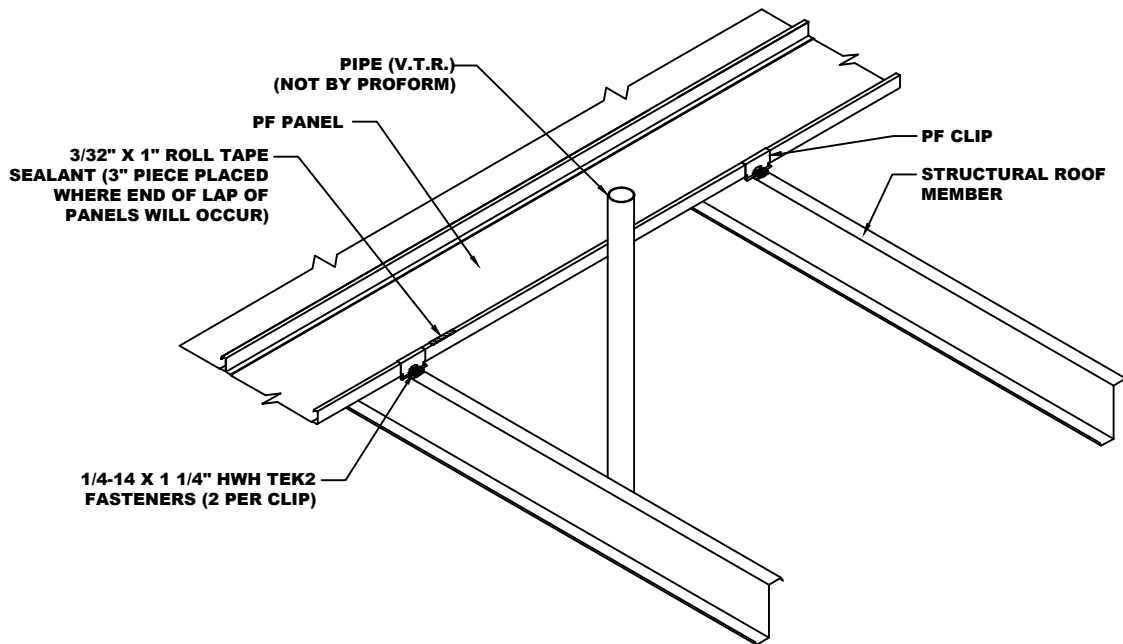

STEP #1

NOTE: SOME TRIM ITEMS AND FASTENERS HAVE BEEN REMOVED FOR CLARITY OF ISOMETRIC DETAIL.

PF ALTERNATE DEKTITE INSTALLATION DETAIL

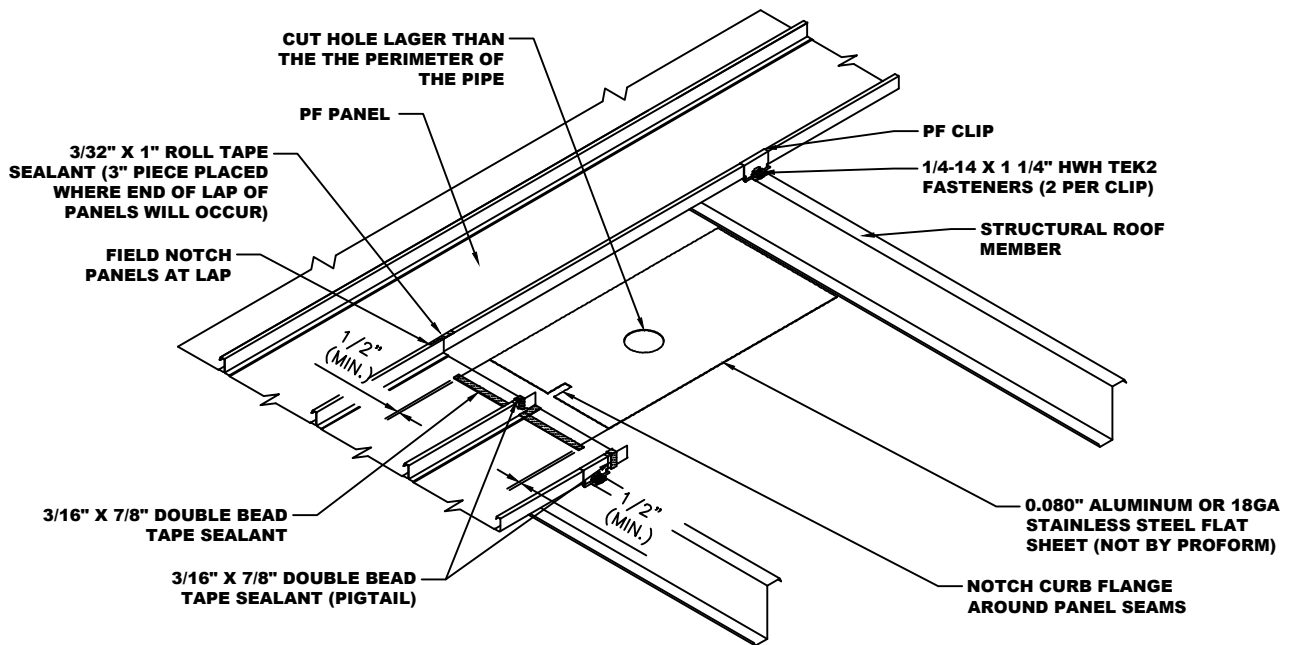

STEP #2

NOTE: SOME TRIM ITEMS AND FASTENERS HAVE BEEN REMOVED FOR CLARITY OF ISOMETRIC DETAIL.

PF ALTERNATE DEKTITE INSTALLATION DETAIL

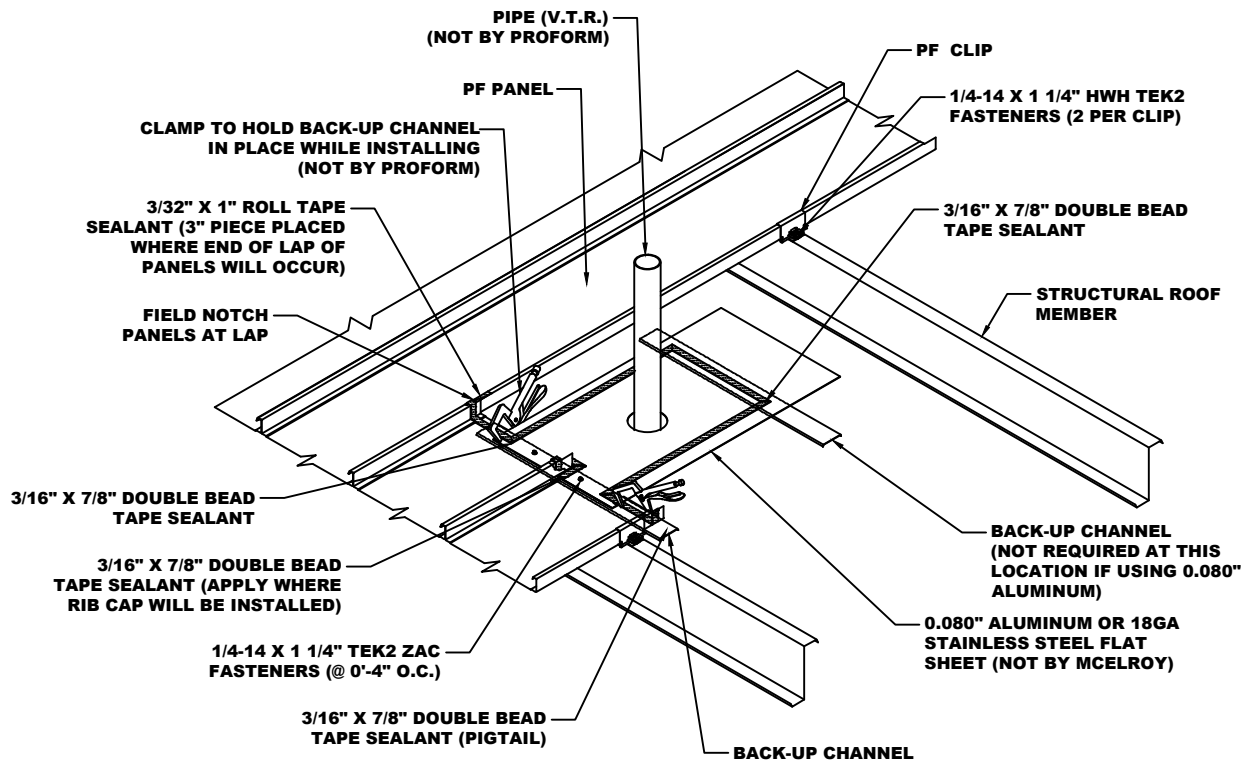

STEP #3

NOTE: SOME TRIM ITEMS AND FASTENERS HAVE BEEN REMOVED FOR CLARITY OF ISOMETRIC DETAIL.

PF ALTERNATE DEKTITE INSTALLATION DETAIL

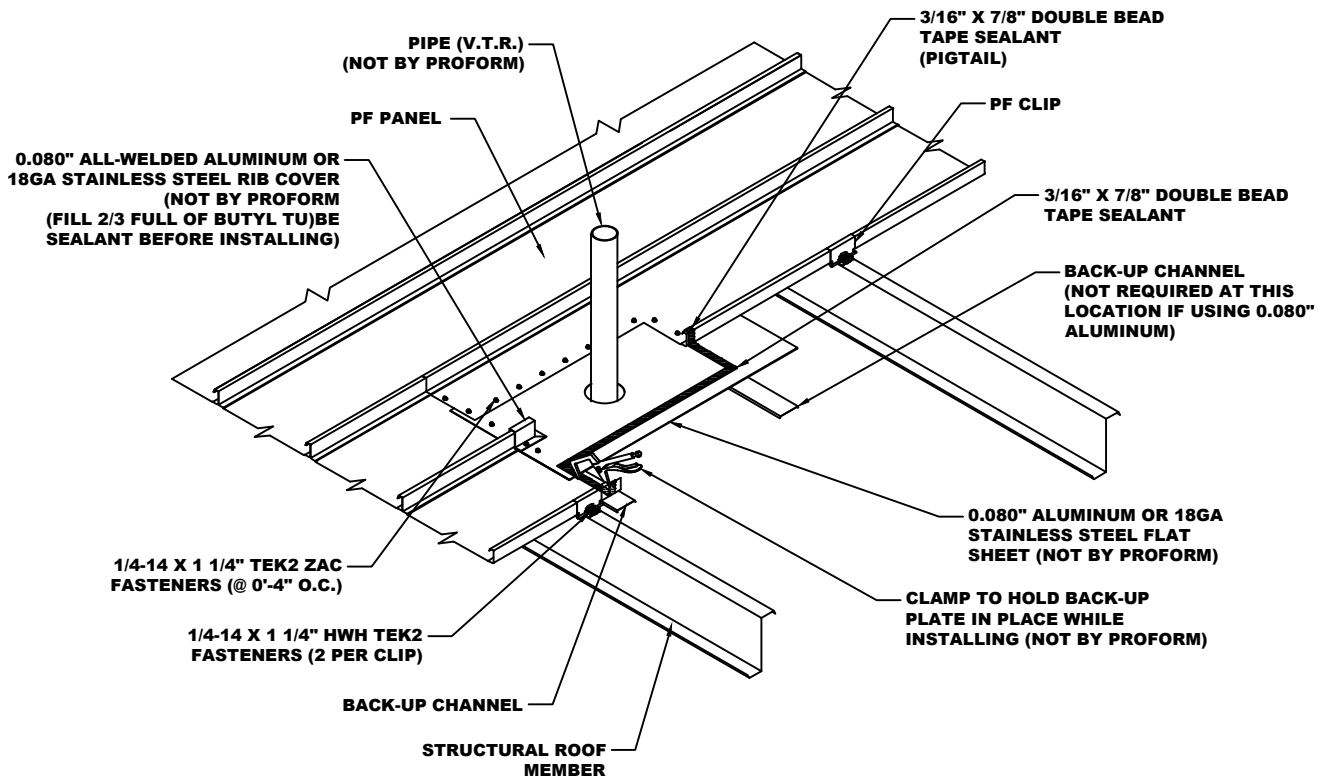

STEP #4

NOTE: SOME TRIM ITEMS AND FASTENERS HAVE BEEN REMOVED FOR CLARITY OF ISOMETRIC

PF ALTERNATE DEKTITE INSTALLATION DETAIL

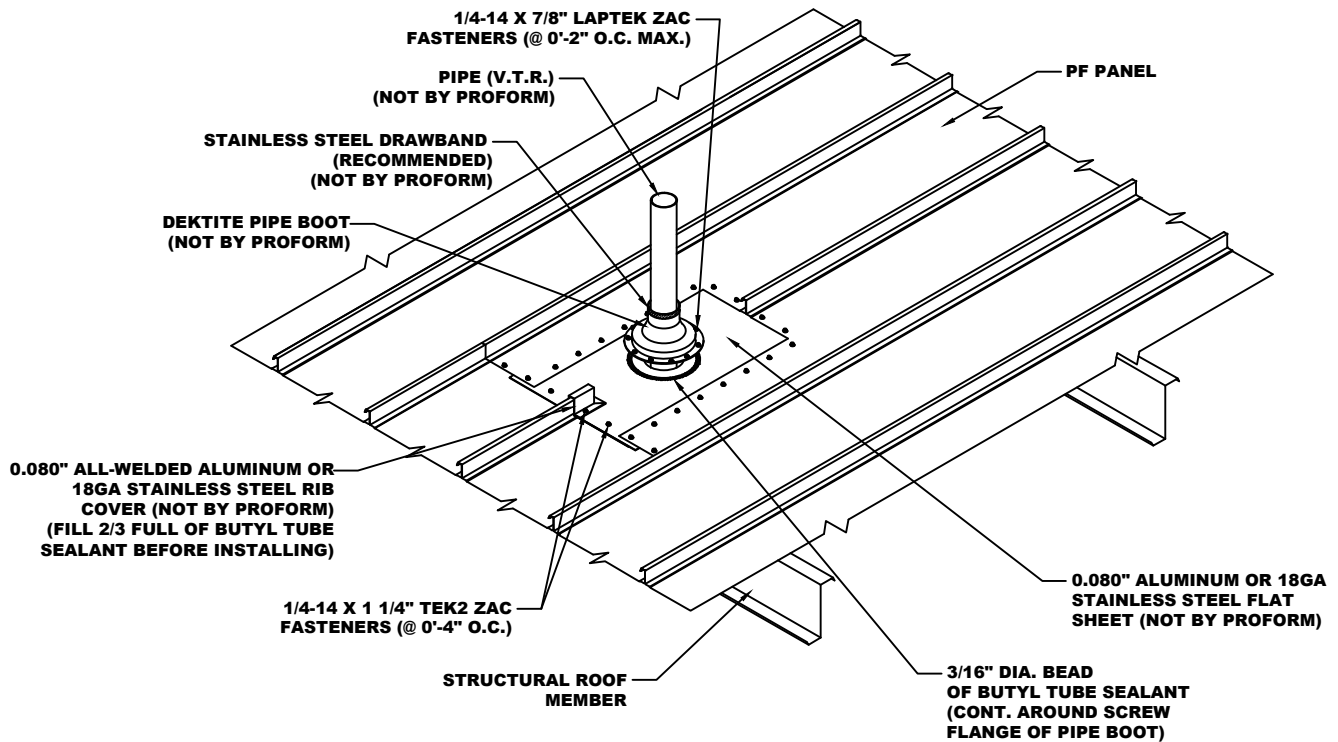

STEP #5

NOTE: SOME TRIM ITEMS AND FASTENERS HAVE BEEN REMOVED FOR CLARITY OF ISOMETRIC DETAIL.

NOTE: GUTTERS AND PENETRATIONS SHOULD BE PROTECTED BY A SNOWGUARD SYSTEM TO PREVENT DAMAGE FROM SLIDING ICE AND SNOW.

PF ROOF CURB INSTALLATION DETAIL

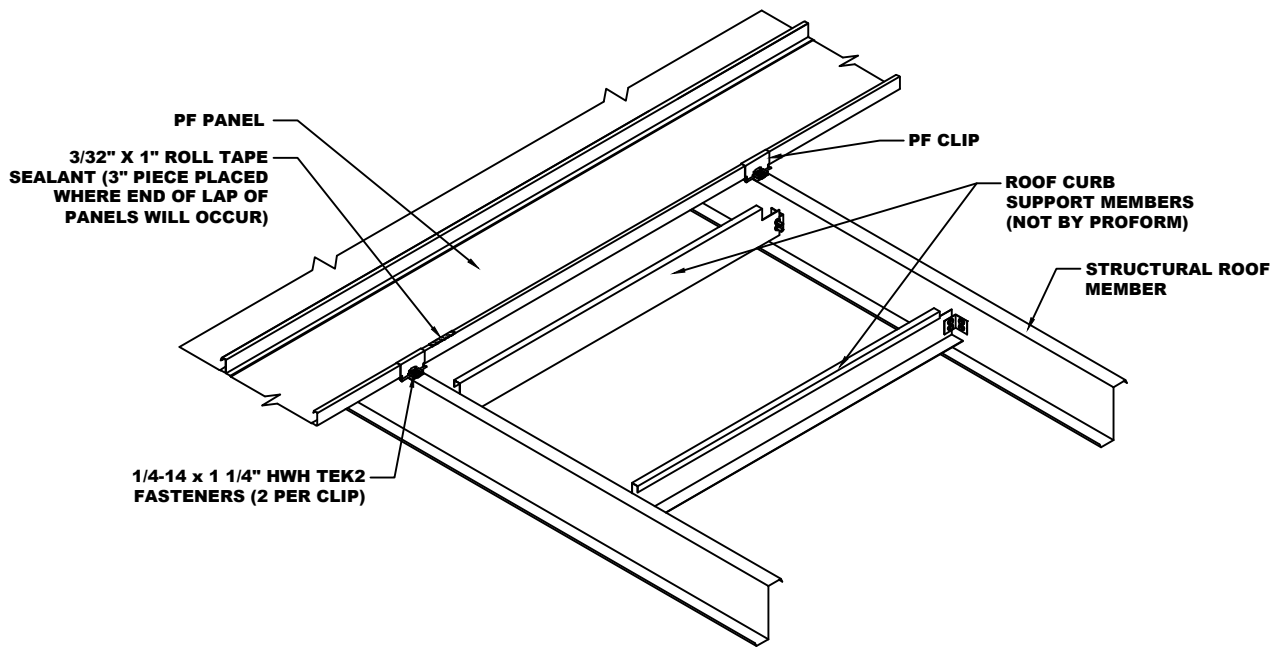

STEP #1

NOTE: SOME TRIM ITEMS AND FASTENERS HAVE BEEN REMOVED FOR CLARITY OF ISOMETRIC DFTAIL.

PF ROOF CURB INSTALLATION DETAIL

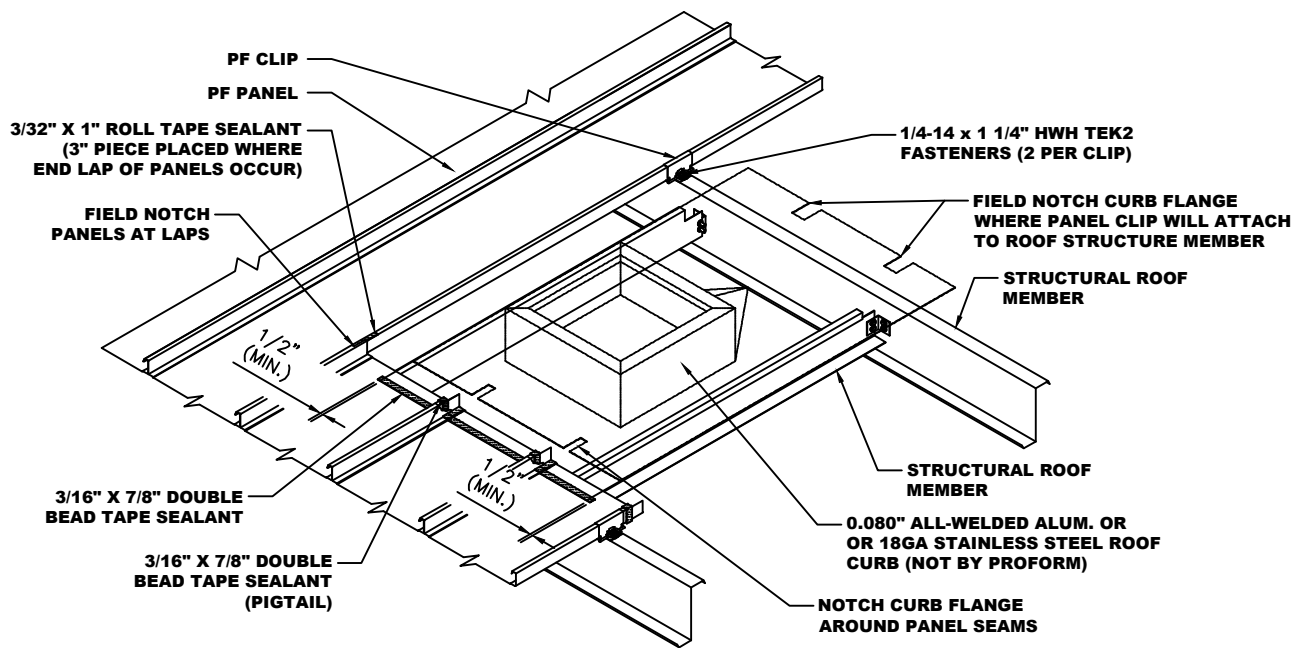

STEP #2

NOTE: SOME TRIM ITEMS AND FASTENERS HAVE BEEN REMOVED FOR CLARITY OF ISOMETRIC DETAIL.

PF ROOF CURB INSTALLATION DETAIL

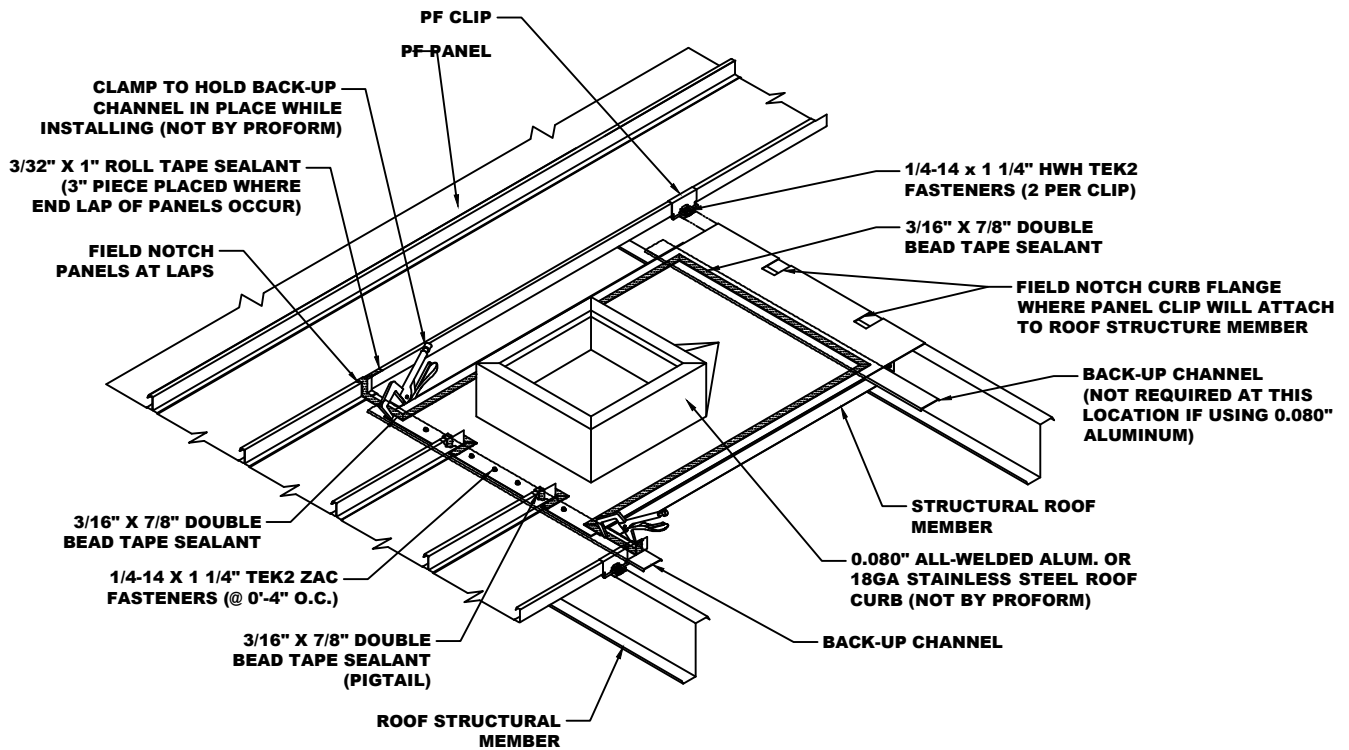

STEP #3

NOTE: SOME TRIM ITEMS AND FASTENERS HAVE BEEN REMOVED FOR CLARITY OF ISOMETRIC DETAIL.

PF ROOF CURB INSTALLATION DETAIL

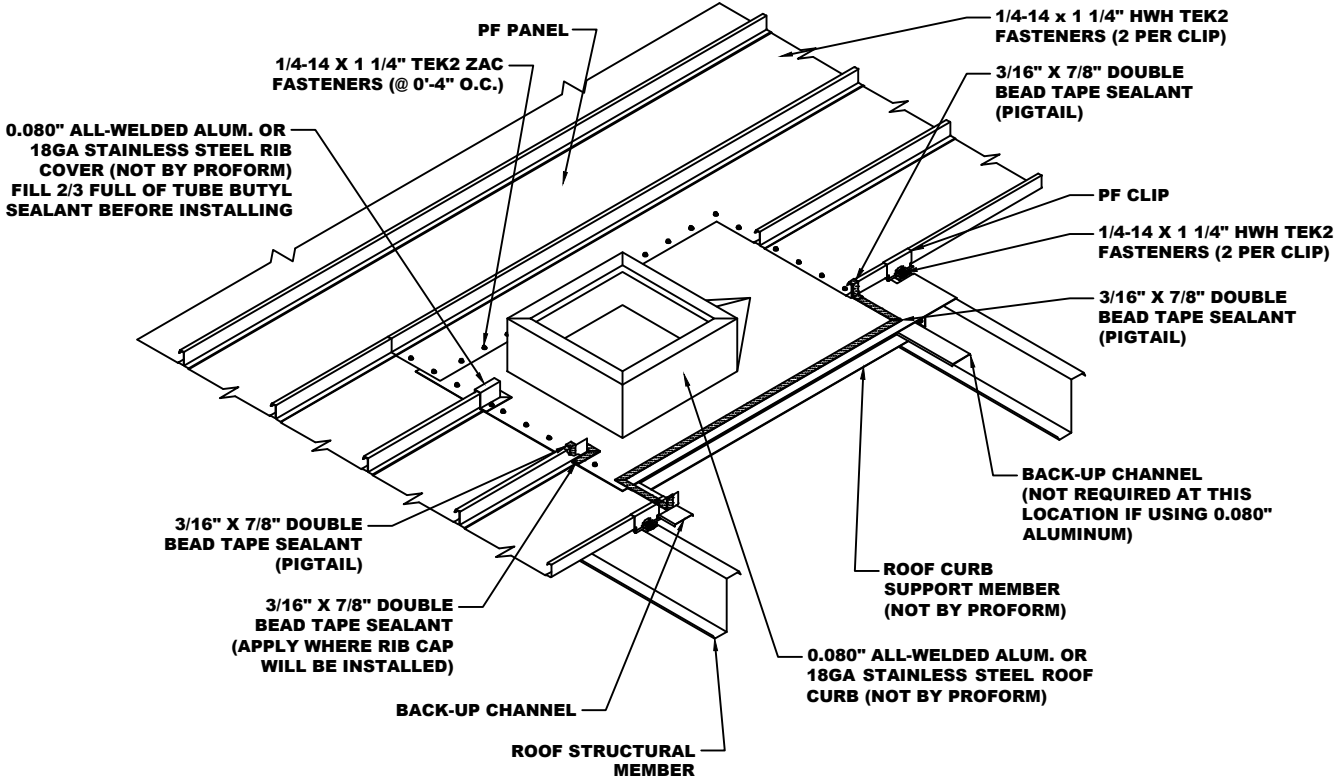

STEP #4

NOTE: SOME TRIM ITEMS AND FASTENERS HAVE BEEN REMOVED FOR CLARITY OF ISOMETRIC DFTAIL.

PF ROOF CURB INSTALLATION DETAIL

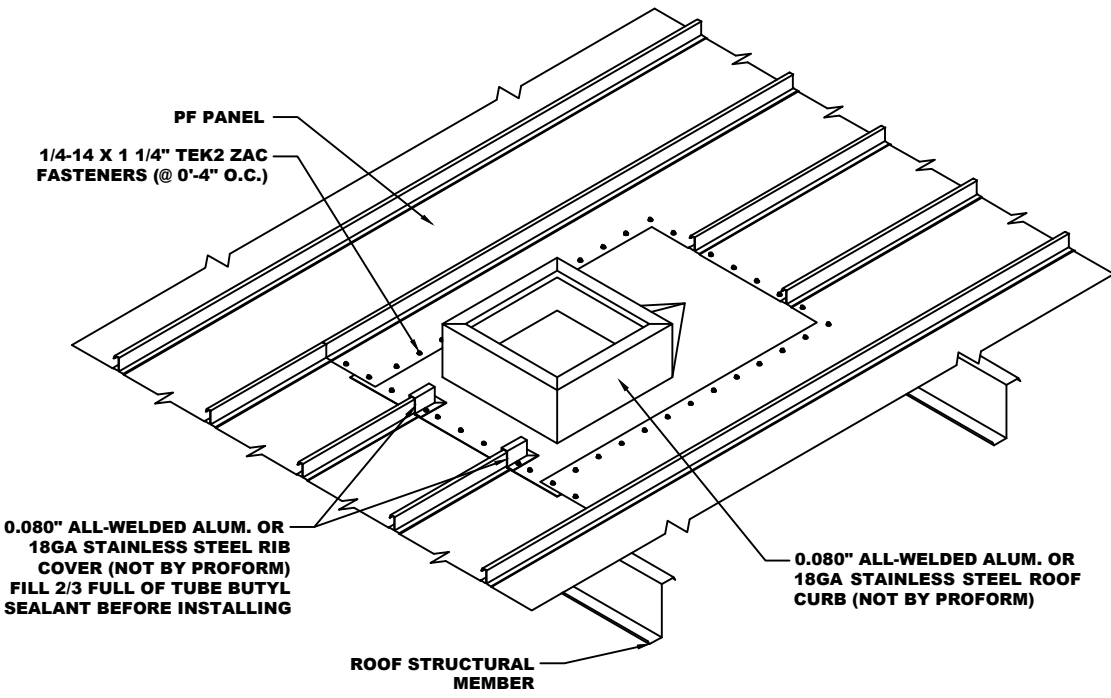

STEP #5

NOTE: SOME TRIM ITEMS AND FASTENERS HAVE BEEN REMOVED FOR CLARITY OF ISOMETRIC DETAIL.

NOTE: GUTTERS AND PENETRATIONS SHOULD BE PROTECTED BY A SNOWGUARD SYSTEM TO PREVENT DAMAGE FROM SLIDING ICE AND SNOW.

PF TYPICAL TRIM LAP DETAIL

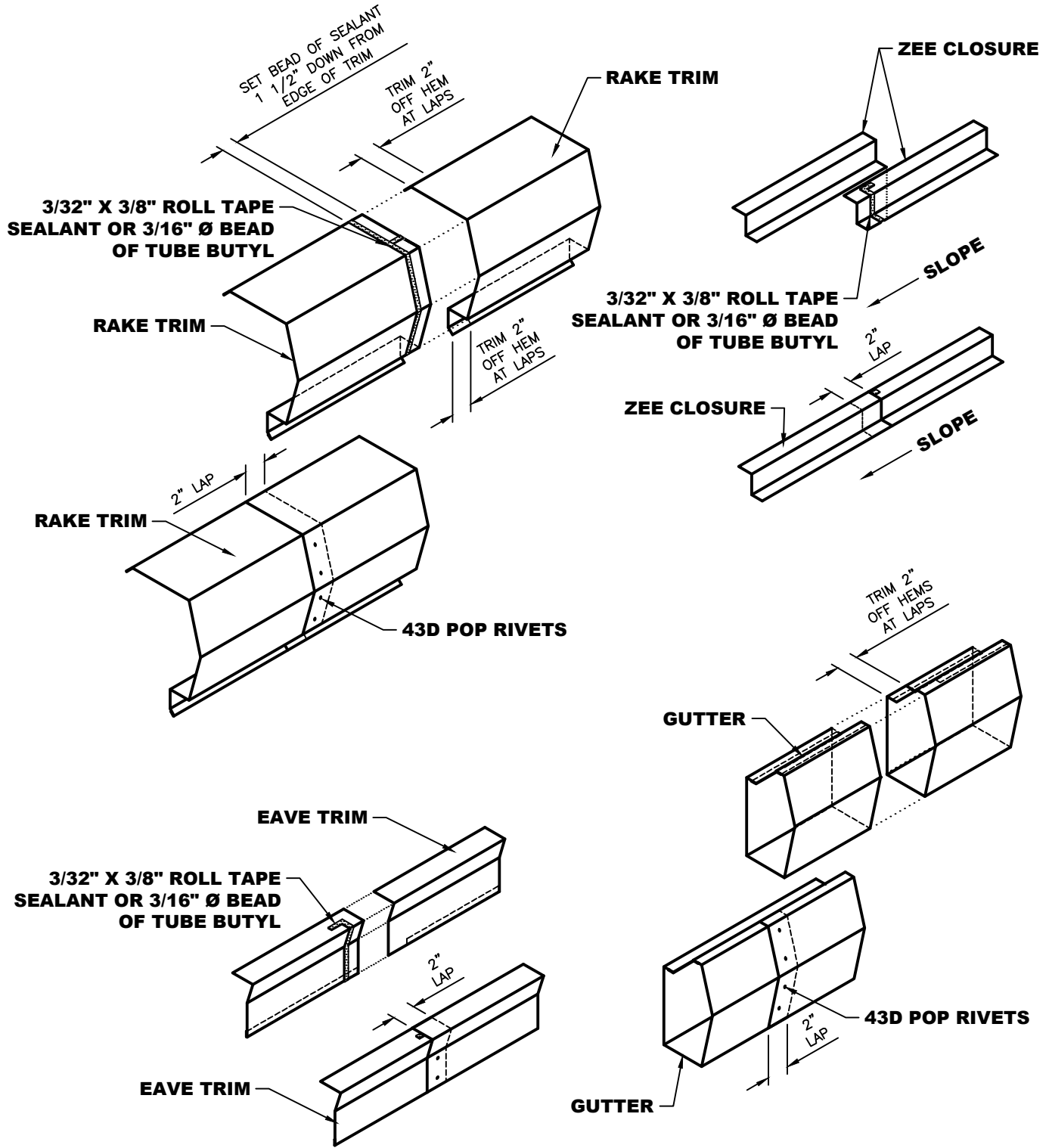

NOTE: 1. Apply 3/32" x 3/8" Roll Tape Sealant or a 3/16" Ø bead of Tube Butyl 1 1/2" back from the edge of the trim. Also, apply a piece of tape sealant or bead of Tube Butyl as a Pigtail to completely seal joint.
 2. Notch the hems on the upper trim piece 2" so that the trim will fit flat in the lap joint.
 3. Secure trim laps with Pop Rivets as shown above.

PF TYPICAL TRIM LAP DETAIL

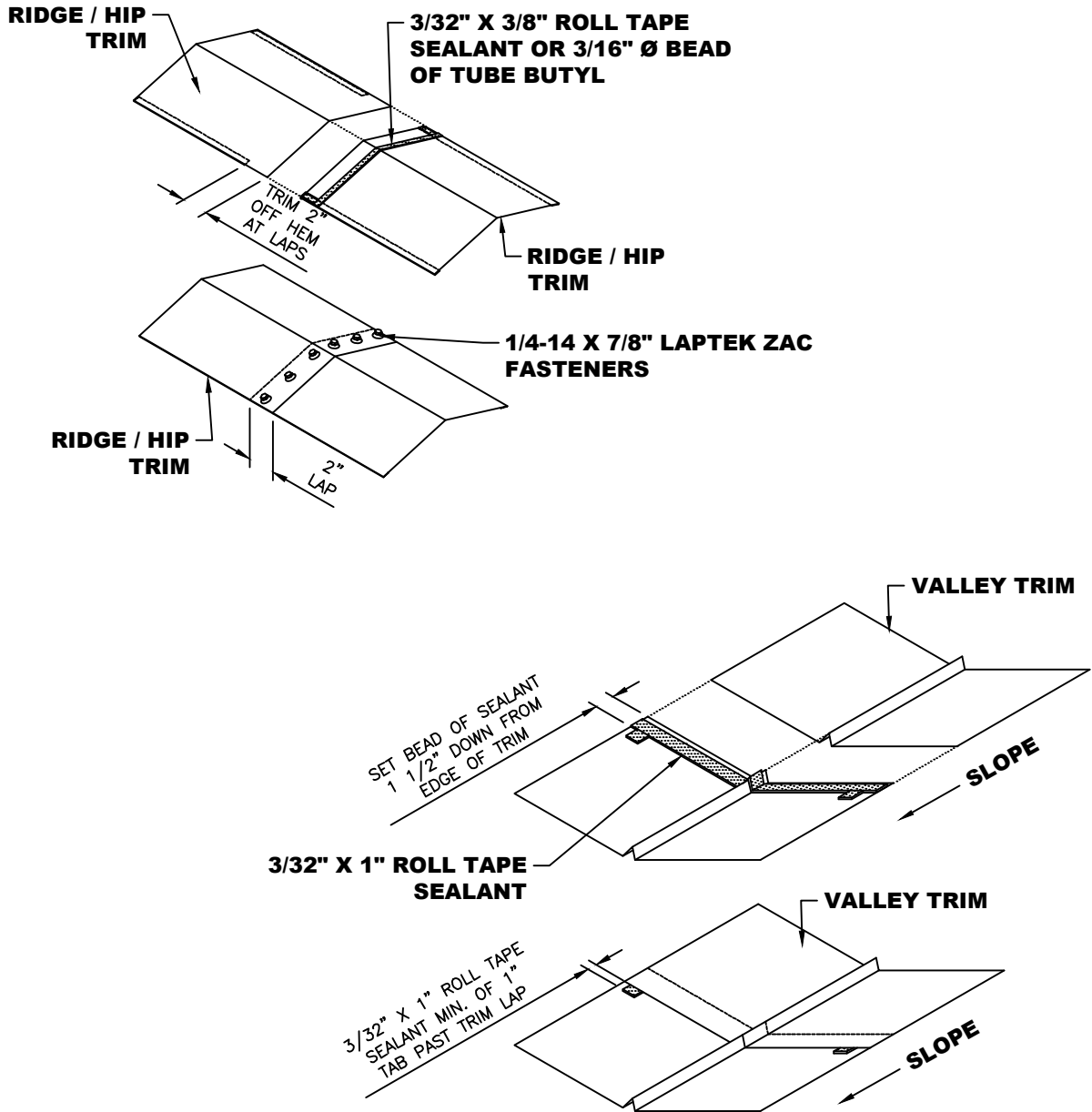

NOTE: 1. Apply 3/32" x 3/8" Roll Tape Sealant or a 3/16" Ø bead of Tube Butyl 1 1/2" back from the edge of the trim. Also, apply a piece of tape sealant or bead of Tube Butyl as a Pigtail to completely seal joint.
2. Notch the hems on the upper trim piece 2" so that the trim will fit flat in the lap joint.
3. Secure trim laps with 1/4-14 x 7/8" LapTek Zac Fasteners as shown above.