

100Gb/s QSFP28 ZR4 Transceiver

QSFP28-100G-ZR4

Product Features

- QSFP28 MSA compliant
- Hot pluggable 38 pin electrical interface
- 4 LAN-WDM lanes MUX/DEMUX design
- 4x25G electrical interface
- Maximum power consumption 6.5W
- LC duplex connector
- Supports 103.125Gb/s aggregate bit rate
- Up to 80km transmission on single mode fiber
- Operating case temperature: 0°C to 70°C
- Single 3.3V power supply
- RoHS 2.0 compliant

Applications

- 100GBASE-ZR4 100G Ethernet
- Telecom networking

Descriptions

QSFP28 is designed for 80km optical communication applications. This module contains 4lane optical transmitter, 4-lane optical receiver and module management block including 2 wire serial interface. The optical signals are multiplexed to a single-mode fiber through an industry standard LC connector. A block diagram is shown in Figure 1.



Transceiver Block Diagrams

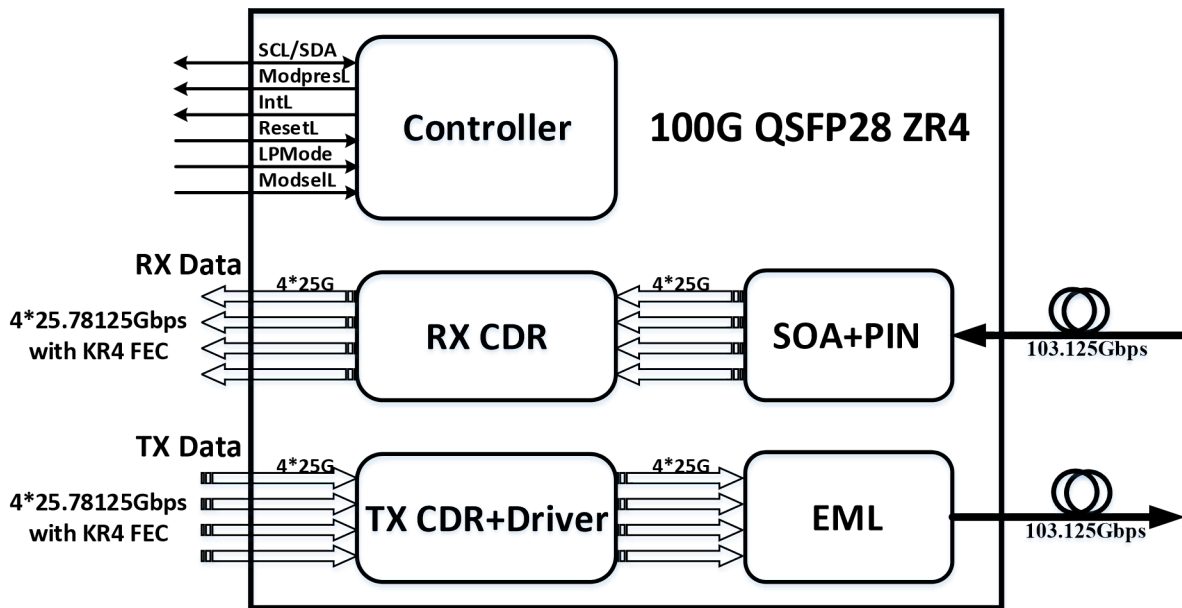

Figure 1. Transceiver Block Diagram

Pin Descriptions

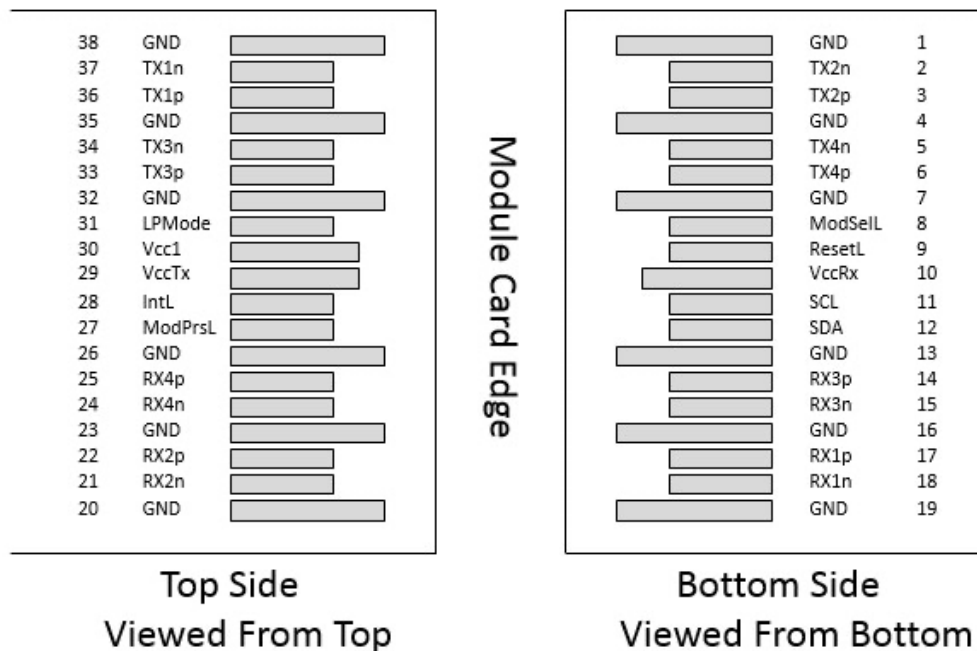

Figure 2. MSA compliant Connector

Pin	Symbol	Description	Notes
1	GND	Ground	1
2	Tx2n	Transmitter Inverted Data Input	

3	Tx2p	Transmitter Non-Inverted Data Input	
4	GND	Ground	1
5	Tx4n	Transmitter Inverted Data Input	
6	Tx4p	Transmitter Non-Inverted Data Input	
7	GND	Ground	1
8	ModSelL	Module Select	
9	ResetL	Module Reset	
10	Vcc Rx	+3.3V Power Supply Receiver	
11	SCL	2-wire serial interface clock	
12	SDA	2-wire serial interface data	
13	GND	Ground	1
14	Rx3p	Receiver Non-Inverted Data Output	
15	Rx3n	Receiver Inverted Data Output	
16	GND	Ground	1
17	Rx1p	Receiver Non-Inverted Data Output	
18	Rx1n	Receiver Inverted Data Output	
19	GND	Ground	1
20	GND	Ground	1
21	Rx2n	Receiver Inverted Data Output	
22	Rx2p	Receiver Non-Inverted Data Output	
23	GND	Ground	1
24	Rx4n	Receiver Non-Inverted Data Output	
25	Rx4p	Receiver Inverted Data Output	
26	GND	Ground	1
27	ModPrsL	Module Present	
28	IntL	Interrupt	
29	Vcc Tx	+3.3V Power supply transmitter	
30	Vcc1	+3.3V Power supply	
31	LPMODE	Low Power Mode	
32	GND	Ground	1
33	Tx3p	Transmitter Non-Inverted Data Input	
34	Tx3n	Transmitter Inverted Data Input	
35	GND	Ground	1
36	Tx1p	Transmitter Non-Inverted Data Input	
37	Tx1n	Transmitter Inverted Data Input	
38	GND	Ground	1

Note: 1. Circuit ground is internally isolated from chassis ground.

Absolute Maximum Ratings

It has to be noted that the operation in excess of any individual absolute maximum ratings might cause permanent damage to this module.

Parameter	Symbol	Min	Typ	Max	Unit	Notes
Maximum Supply Voltage	Vcc	0		3.6	V	
Storage Temperature	Ts	-40		85	°C	
Relative Humidity	RH	5		85	%	1
Damage Threshold, each lane	THd	6.5			dBm	

Note: 1. Non-condensing

Operating Environments

Electrical and optical characteristics below are defined under this operating environment, unless otherwise specified.

Parameter	Symbol	Min	Typ	Max	Unit
Supply Voltage	Vcc	3.135	3.3	3.465	V
Case Temperature	Top	0		70	°C
Link Distance with G.652				80	km

Electrical Characteristics

Parameter	Symbol	Min	Typ	Max	Unit	Note
Power dissipation				6.5	W	
Supply Current	Icc			1.8759	A	Steady state
Transmitter						
Data Rate, each lane			25.78125		Gbps	
Differential Voltage pk-pk	Vpp			900	mV	At 1 MHz
Common Mode Voltage	Vcm	-350		2850	mV	
Transition time	Trise/Tfall	10			ps	20%~80%
Differential Termination Resistance Mismatch				10	%	
Eye width	EW15	0.46			UI	
Eye height	EH15	95			mV	
Receiver						
Data Rate, each lane			25.78125		Gbps	
Differential Termination Resistance Mismatch				10	%	At 1 MHz
Differential output voltage swing	Vout, pp			900	mV	
Common Mode Noise, RMS	Vrms			17.5	mV	
Transition time	Trise/Tfall	12			ps	20%~80%

Eye width	EW15	0.57			UI	
Eye height	EH15	228			mV	

Optical Characteristics

100GBASE-ZR4 Operation (EOL, TOP = 0 to +70 °C , VCC = 3.135 to 3.465 Volts)

Parameters	Unit	min	type	max	Note
Transmitter					
Signaling Speed per Lane	Gb/s	25.78125 ± 100 ppm			
Transmit wavelengths	nm	1294.53		1296.59	
		1299.02		1301.09	
		1303.54		1305.63	
		1308.09		1310.19	
Side-Mode Suppression Ratio (SMSR)	dB	30			
Total Average Launch Power	dBm	8.0		12.5	
Average launch power, each lane	dBm	2.0		6.5	
Difference in launch power between any two lanes(Average and OMA)	dBm			3	
Average launch power of OFF transmitter, each lane	dBm			-30	
Extinction Ratio (ER)	dB	6			
RIN OMA	dB/Hz			-130	
Optical return loss tolerance	dB			20	
Transmitter reflectance	dB			-12	
Transmitter eye mask definition {X1, X2, X3, Y1, Y2, Y3}		{0.25, 0.4, 0.45, 0.25, 0.28, 0.4}			1
Mask margin	%	5			
Receiver					
Signaling Speed per Lane	Gb/s	25.78125 ± 100 ppm			
Receive wavelengths	nm	1294.53		1296.59	
		1299.02		1301.09	
		1303.54		1305.63	
		1308.09		1310.19	
Average receiver power, each lane	dBm	-28		-7	
Receiver power, each lane(OMA)	dBm			-7	
Receiver reflectance	dB			-26	

Receiver sensitivity Average, each lane	dBm			-28	1
Receiver 3 dB electrical upper cutoff frequency, each lane	GHz			31	
Damage threshold, each lane	dBm	6.5			
LOS Assert	dBm	-40			
LOS Deassert	dBm			-29	
LOS Hysteresis	dB	0.5			

Note: 1. Sensitivity is specified at BER@5E-5 with FEC

Digital Diagnostic Monitoring Functions

QSFP28-100G-ZR4 support the I2C-based Diagnostic Monitoring Interface (DMI) defined in document SFF8636. The host can access real-time performance of transmitter and receiver optical power, temperature, supply voltage and bias current.

Performance Item	Related Bytes(A0[00] memory)	Monitor Error	Notes
Module temperature	22 to 23	+/-3°C	1, 2
Module voltage	26 to 27	< 3%	2
LD Bias current	42 to 49	< 10%	2
Transmitter optical power	50 to 57	< 3dB	2
Receiver optical power	34 to 41	< 3dB	2

Note:

1. Actual temperature test point is fixed on module case around Laser.
2. Full operating temperature range

Alarm and Warning Thresholds

QSFP28-100G-ZR4 support alarms function, indicating the values of the preceding basic performance are lower or higher than the thresholds.

Performance Item	Alarm Threshold Bytes(A0[03] memory)	Unit	Low threshold	High threshold
Temp Alarm	128 to 131	°C	-10	80
Temp Warning	132 to 135	°C	0	70
Voltage Alarm	144 to 147	V	2.97	3.63
Voltage Warning	148 to 151	V	3.135	3.465
TX Power Alarm	192 to 195	dBm	-4	8.2
TX Power Warning	196 to 199	dBm	-1	6.5
RX Power Alarm	176 to 179	dBm	-31	-4
RX Power Warning	180 to 183	dBm	-28	-7

Mechanical Specifications

QSFP28-100G-ZR4 100G ZR4 QSFP28 transceivers are compatible with the QSFP28 Specification for pluggable form factor modules.

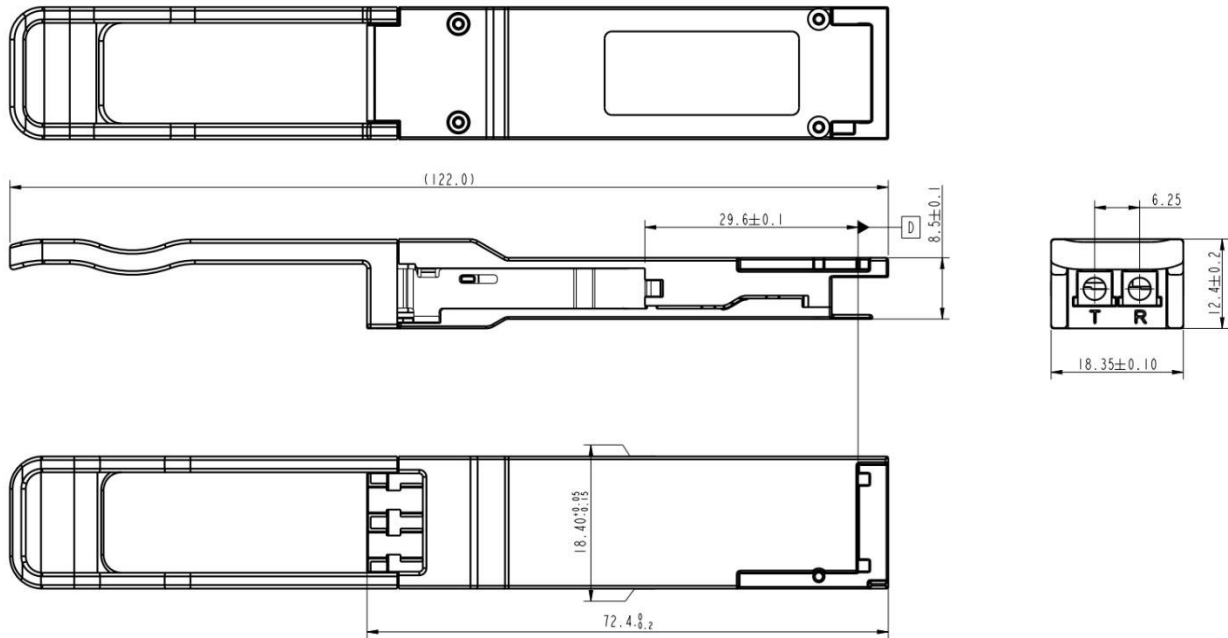

Figure 3. Mechanical Dimensions

ESD Design

Normal ESD precautions are required during the handling of this module. This transceiver is shipped in ESD protective packaging. It should be removed from the packaging and otherwise handled in an ESD protected environment utilizing standard grounded benches, floor mats, and wrist straps.

Parameter	Threshold value	Notes
ESD of high-speed pins	1KV	Human Body Model
ESD of low-speed pins	2KV	Human Body Model
Air discharge during operation	15KV	
Direct contact discharges to the case	8KV	

Safety Specification Design



Cautions

- 1) Do not look into fiber end faces without eye protection using an optical meter (such as magnifier and microscope) within 100 mm, unless you ensure that the laser output is disabled. When operating an optical meter, observe the operation requirements.
- 2) The RX input optical power cannot be higher than the damage threshold. You need the optical attenuator with RX in order to meet the input optical power range if necessary.
- 3) The QSFP28-100G-ZR4 is the customized module, it can only interconnect with the QSFP28-100G-ZR4 module.

CAUTION: Use of controls or adjustments or performance of procedures other than those specified herein may result in hazardous radiation exposure.

Ordering Information

Part Number	Description
QSFP28-100G-ZR4	100GBASE-ZR4 80km QSFP28 Transceiver



Edition January, 2024
Published by DukeVilla LLC
Copyright © DukeVilla
All Rights Reserved

