

200Gb/s QSFP56 SR4 Transceiver

QSFP56-200G-SR4

Features

- Compliant with 200G-SR4 optical specifications
- 4x53.125Gb/s electrical interface (200GAUI-4)
- Reach up to 70m on MMF(OM3)
- Reach up to 100m on MMF(OM4)
- Single +3.3V power supply
- Case temperature range: 0 ~ +70°C
- Maximum power consumption 4.5W
- Single MPO12 connector
- RoHS complaint

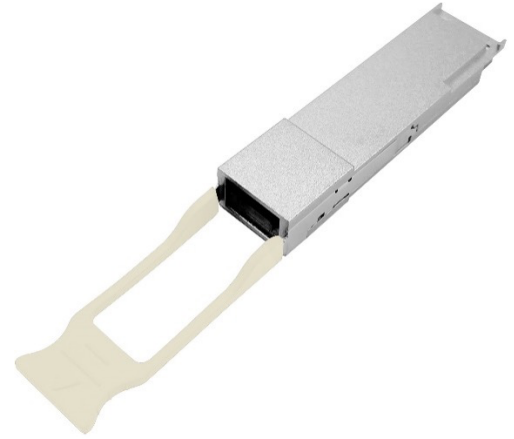

Applications

- 200G BASE-SR4 Ethernet links
- Data centers
- CMIS4.0 or SFF8636

Standards

- IEEE 802.3cd
- SFF 8679

Description

The 200G QSFP56 SR4 is a 4x53.125Gbps multi mode fiber, hot pluggable optical transceiver. The module integrates four parallel lanes with baud rate at 26.5625GBd each lane. It can transmit up to 70m on fiber OM3 fiber or 100m on OM4 fiber with FEC.

Absolute Maximum Ratings

Parameter	Symbol	Min	Max	Unit
Supply Voltage	V_{CC}	-0.3	3.6	V
Input Voltage	V_{in}	-0.3	$V_{CC}+0.3$	V
Storage Temperature	T_s	-40	85	°C
Case Operating Temperature	T_c	0	70	°C
Humidity (non-condensing)	Rh	5	95	%

Recommended Operating Conditions

Parameter	Symbol	Min	Typical	Max	Unit
Supply Voltage	V_{cc}	3.13	3.3	3.47	V
Operating Case Temperature	T_c	0		70	°C
Baud Rate per Lane (PAM4)	f_d		26.5625		GBaud/s
Humidity	Rh	5		85	%
Power Dissipation	P_m		4.1	4.5	W
Fiber Bend Radius	R_b	3			cm

Electrical Specifications

Parameter	Symbol	Min	Typical	Max	Unit
Differential Input Impedance	Z_{in}	90	100	110	ohm
Differential Output Impedance	Z_{out}	90	100	110	ohm
Differential Input Voltage Amplitude	ΔV_{in}	300		1000	mVpp
Differential Output Voltage Amplitude	ΔV_{out}	300		900	mVpp
Bit Error Rate ^{Note}	BER			2.4E-4	
Input Logic Level High	V_{IH}	2.0		V_{cc}	V
Input Logic Level Low	V_{IL}	0		0.8	V
Output Logic Level High	V_{OH}	$V_{cc}-0.5$		V_{cc}	V
Output Logic Level Low	V_{OL}	0		0.4	V

Note:

1. Compliant with 200GBASE-SR4 electrical specification in IEEE802.3cd standard.

Optical Characteristics

Parameter	Symbol	Min	Typical	Max	Unit
Transmitter					
Center Wavelength	λ_c	840	850	860	nm
RMS Spectral Width	$\Delta\lambda$			0.6	nm
Average Launch Power (each lane)	P_{out}	-6.5		4	dBm
Outer Optical Modulation Amplitude (each lane)	OMA_{out}	-4.5		3	dBm
Launch power in OMA_{outer} minus TDECQ	P_{tdecq}	-5.9			dBm

Transmitter and dispersion eye closure (each lane)	TDEC			4.5	dB
Average launch power of off transmitter(each lane)	P _{off}			-30	dBm
Outer Extinction Ratio	ER	3			dB
Optical Return Loss Tolerance	ORLT			12	dB
Receiver					
Center Wavelength	λ_c	840	850	860	nm
Damage threshold	R _{dam}			4	dBm
Average Receive Power (each lane)	P _{in}	-7.9		4	dBm
Input Receiver(each Power lane)(OMA _{outer}) (each lane)	OMA _{out}			3	dBm
Receiver reflectance	P _{ref}			-12	dB
Stressed Receiver Sensitivity (OMA _{outer}) (each lane)	Sens			-3	dBm
Receiver Sensitivity (OMA _{outer}) (each lane) ^{Note}	Sen			-7	dBm
LOS Assert				-10	dBm
LOS De-Assert				-8.5	dBm
LOS Hysteresis		0.5			dB

Note:

1. Measured with conformance test signal at TP3 for BER = 2.4E-4 Pre-FEC

Pin Description

Pin	Logic	Symbol	Name/Description
1		GND	Module Ground
2	CML-I	Tx2-	Transmitter inverted data input
3	CML-I	Tx2+	Transmitter non-inverted data input
4		GND	Module Ground
5	CML-I	Tx4-	Transmitter inverted data input
6	CML-I	Tx4+	Transmitter non-inverted data input
7		GND	Module Ground
8	LVTTL-I	MODSEIL	Module Select
9	LVTTL-I	ResetL	Module Reset
10		VCCR _x	+3.3V Receiver Power Supply
11	LVC MOS-I	SCL	2-wire Serial interface clock
12	LVC MOS-I/O	SDA	2-wire Serial interface data
13		GND	Module Ground
14	CML-O	RX3+	Receiver non-inverted data output

15	CML-O	RX3-	Receiver inverted data output
16		GND	Module Ground
17	CML-O	RX1+	Receiver non-inverted data output
18	CML-O	RX1-	Receiver inverted data output
19		GND	Module Ground
20		GND	Module Ground
21	CML-O	RX2-	Receiver inverted data output
22	CML-O	RX2+	Receiver non-inverted data output
23		GND	Module Ground
24	CML-O	RX4-	Receiver inverted data output
25	CML-O	RX4+	Receiver non-inverted data output
26		GND	Module Ground
27	LVTTL-O	ModPrsL	Module Present, internal pulled down to GND
28	LVTTL-O	IntL	Interrupt output, should be pulled up on host board ²
29		VCCTx	+3.3V Transmitter Power Supply
30		VCC1	+3.3V Power Supply
31	LVTTL-I	LPMoDe	Low Power Mode
32		GND	Module Ground
33	CML-I	Tx3+	Transmitter non-inverted data input
34	CML-I	Tx3-	Transmitter inverted data input
35		GND	Module Ground
36	CML-I	Tx1+	Transmitter non-inverted data input
37	CML-I	Tx1-	Transmitter inverted data input
38		GND	Module Ground

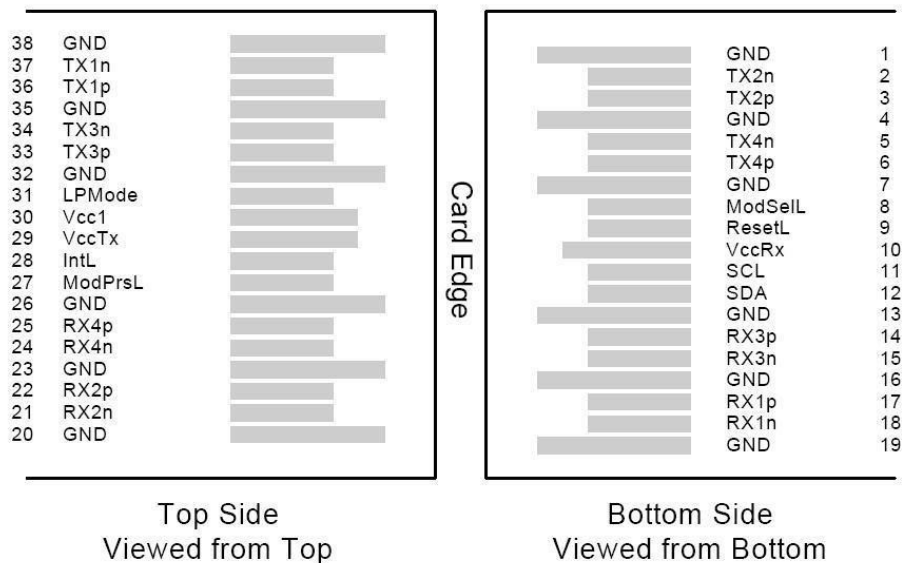

Optical interface

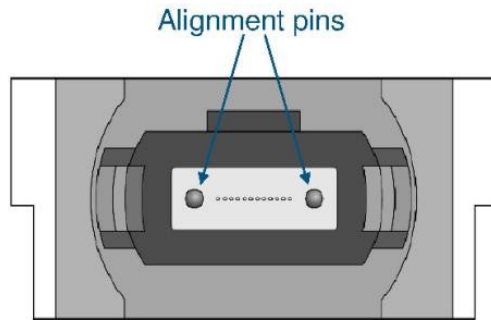

Transmit Channels: 1 2 3 4
 Unused positions: x x x x
 Receive Channels: 4 3 2 1

Mechanical Specifications

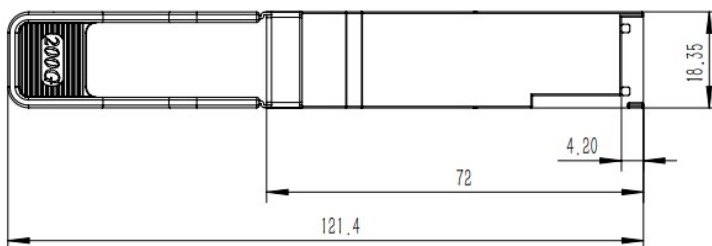
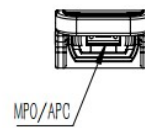
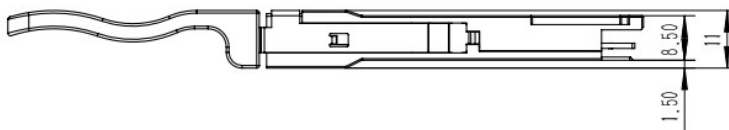
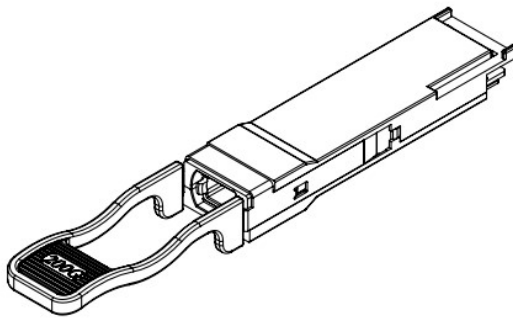

Ordering Information

Part Number	Product Description
QSFP56-200G-SR4	QSFP56, 200GBASE-SR4, 70m on OM3 MMF and 100m on OM4 MMF

Important Notice

Performance figures, data and any illustrative material provided in this data sheet are typical and must be specifically confirmed in writing by DUKEVILLA before they become applicable to any particular order or contract. In accordance with the DUKEVILLA policy of continuous improvement specifications may change without notice.

The publication of information in this data sheet does not imply freedom from patent or other protective rights of DUKEVILLA or others. Further details are available from any DUKEVILLA sales representative.

sales@duke-villa.com

www.duke-villa.com



Edition January, 2024
Published by DukeVilla LLC
Copyright © DukeVilla
All Rights Reserved

