



CENTURY DYNAMICS ARMS



PK-12 Vertical Mag Fed AR-12

MAGAZINE FED SEMI- AUTOMATIC SHOTGUN INSTRUCTION MANUAL

CENTURY DYNAMICS

READ THE INSTRUCTIONS AND WARNINGS IN THIS MANUAL CAREFULLY BEFORE
USING THIS FIREARM

CENTURY DYNAMICS ARMS
FORT WORTH, TX

GUN SAFETY RULES

Observe these rules of safe gun handling.

1. Always keep the muzzle pointed in a safe direction. Watch the muzzle at all times: never point a gun, accidentally or intentionally, at any person or anything you do not intend to shoot. identify the target before shooting; do not shoot at sounds.
2. Always treat any gun as if it is loaded - it may be!
3. Keep your finger off the trigger while operating the action and at all other times until you are ready to shoot.
4. Keep the safety "on" or in the "safe" position at all times until you are ready to fire the gun. Move to shoot. Up to the previous line after the word intend to shoot. Do not rely on your gun's safety, the safety on any gun is a mechanical device and is not intended as a substitute for common sense or safe gun handling.
5. Learn how your gun functions and handles. If you do not thoroughly understand the proper use and care of your gun, seek the advice of someone who is knowledgeable.
6. Do not alter or modify and parts of a firearm.
7. Store guns unloaded, separate from any ammunition, and where children cannot get to them.
8. Be sure the barrel is clear of any obstructions before loading. Make it a habit to check the barrel every time before loading.
9. Be sure you have and use the proper ammunition. A 20-gauge shell will enter a 12-gauge chamber far enough so that a 12-gauge shell can be loaded behind it. Also, a 3-inch shell may fit into a 2 3/4-inch chamber, but the crimp at the mouth of the shell will unfold into the forcing cone. If either of these things occur and you fire the gun, the gun will explode, damaging the gun and possibly causing serious injury or death to you and those around you.
10. Wear protective shooting glasses and adequate ear protection when shooting.
11. Never climb or jump over anything, such as a tree, fence, or ditch, with a loaded gun. Open the barrel, remove the shells, and hand the gun to a friend or place it on the ground on the other side of the obstacle before crossing it yourself. Do not lean a gun against a tree or other object; it could fall and possibly discharge.
12. Do not shoot at a hard surface or at water. Bullet and shot can ricochet or bounce off and travel in unpredictable directions with great velocity.
13. Never transport a loaded gun. Do not place a loaded gun into a vehicle. The gun should be unloaded and placed into a case when not in use.
14. Never drink alcoholic beverages before or during shooting.

INTRODUCTION TO BATMAZ GROUP ARMS

For many of years, Batmaz Group Arms has been associated with the gun industry. After the word with modern technology and you have a product of true value and affordable quality. You have Batmaz Group Arms, we as Batmaz Group Arms thank you for the privilege of delivering a product to you that will provide you with years of pleasurable use. Happy shot gunning.

ABOUT YOUR MAGAZINE FED SEMI-AUTOMATIC SHOTGUN Your Batmaz Group Arms shotgun is gas operated.

The gas created from firing a live shot shell operates the action. Once the first shell has been fired, the next shell in the magazine will automatically cycle into the chamber, and this cycle will continue (each time the trigger is pulled) until all shells loaded in the magazine have been fired. The bolt will remain locked in the open position after the last shell is fired.

The technologically advanced gas metering system allows you to shoot 2 3/4 " and 3" shells interchangeably with any ammunition of the proper gauge for your shotgun with flawless performance. This and other fine features ensure that your shotgun will be a source of pride and pleasure for years to come. For 3 1/2" models the metering system allows you to shot heavy 2 3/4", 3" and 3 1/2" shells interchangeably.

SAFETY SWITCH OR BUTTON The safety is designed to stop the trigger mechanism.

DON'T RELY ON YOUR GUN'S SAFETY. TREAT EVERY GUN AS IF IT WERE LOADED AND READY TO FIRE. The safety on any gun is a mechanical device, and it is not intended as a substitute for common sense or safe gun handling. Always keep the muzzle pointed in a safe direction.

GENERAL INFORMATION



1. Point the shotgun in a safe direction and keep fingers off the trigger and out the trigger guard.
2. Depress the magazine catch and remove the magazine.



3. Pull the bolt back and lock it to the rear by depressing the bolt hold open lever. Once the bolt is locked to the rear, both visually and manually inspect the chamber of the shotgun to confirm that the chamber is empty. Also check to make sure the magazine well is clear. Then cycle the bolt forward by pressing the bolt release lever.
4. Unscrew the front handguard secure cap and remove it.
5. Remove the Forearm.



6. After you remove the forearm, push " Cartridge Ramp Lock Button" and remove " Fixing Nut Barrel".
7. Remove the barrel to the rear slightly.



8. Remove the operating handle.



9. You are now ready to remove the bolt, bolt carrier and recoil spring. Remove this set to the rear slightly.
10. Further disassembly is not required for regular cleaning and maintenance.

MECHANISM PARTS

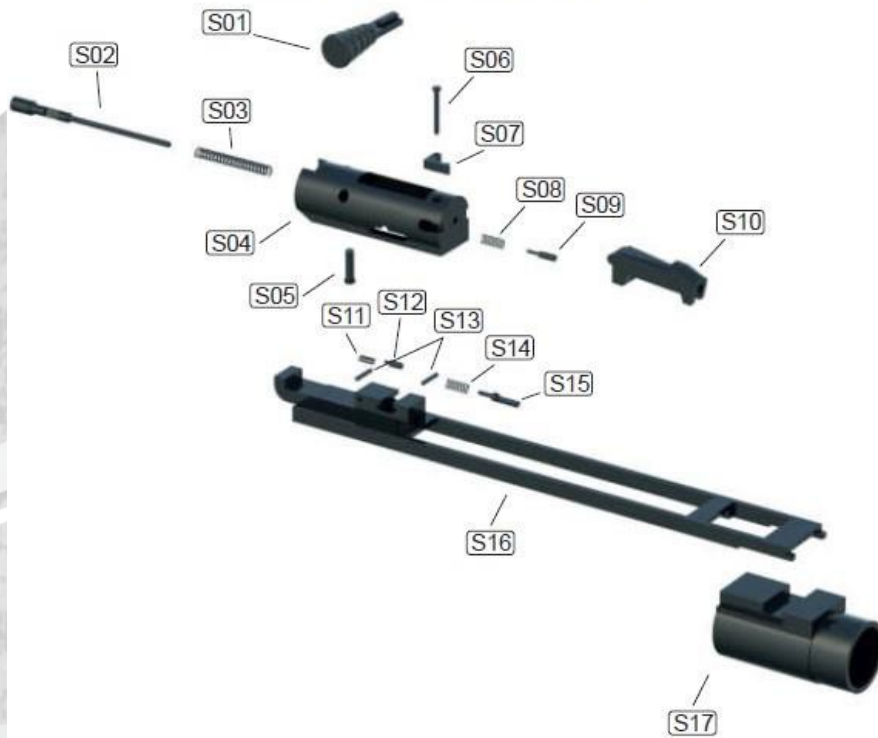

STOCK&BOTTOM RECEIVER AND TRIGGER GROUP PARTS



BARREL AND ASSEMBLY EQUIPMENT PARTS

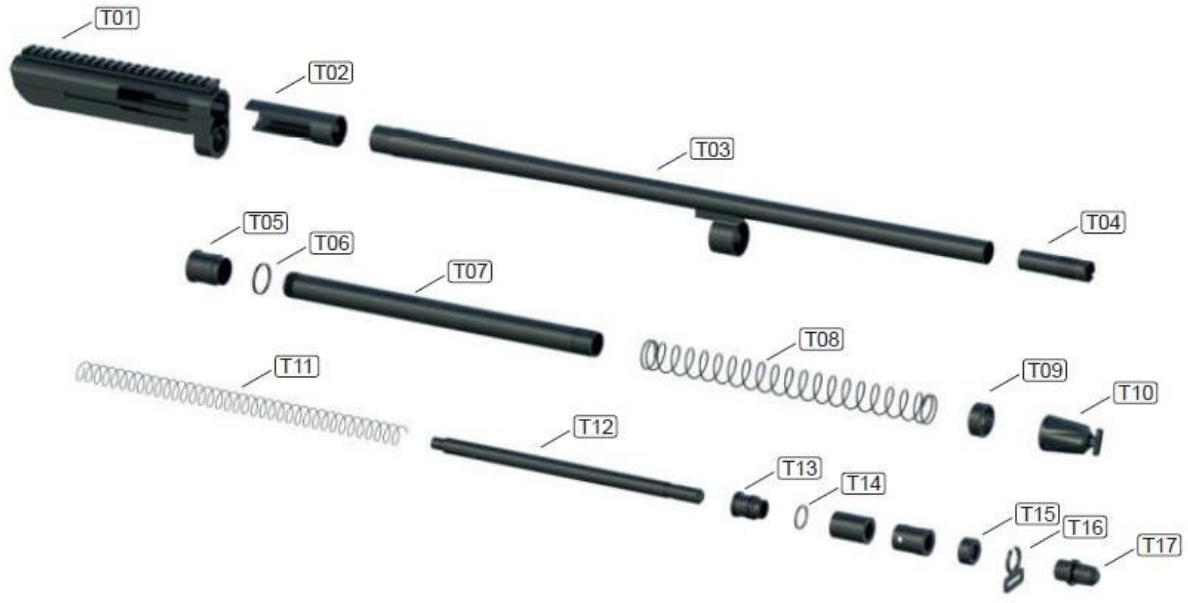

STOCK SETS & MAGAZINE PARTS



MECHANISM PARTS

S01 OPERATING HANDLE
S02 . . I RING PIN
S03 FIR ING PIN SPRIN G
S04 MECHANISM
S05 FIRING PIN CLAMP PIN
S06 EX RACTOR CLAMP PIN
S07 EXTRACTOR
S08 EXTRACTOR SPR IN G
S09 EXTRACTOR BACK PIN
S10 LOCK
S11 OPERATING HAND LOCKING SPRING
S12 OPERA TING HANDLE LOCKING PIN
S13 FIXI N G PIN
S14 MECHANISM FIXING SPRING PIN
S15 MECHANISM FIXING PI
S16 A CH ON BAR
S17 A CTION BAR SL EVE

STOCK&BUTTOM RECEIVER & TRIGGER GROUP PARTS LIST

Ho1 MECHANISM LOCK BREAK
Ho2 CARTRIDGE LIFTER
Ho3 BREAK LOCK ASS MBLING IPIN
Ho4 BREAK LOCK SPRING
Ho5 BREAK LOCK FIXED RECEIVER
H06 SAFETY LINK
Ho7 MAGAZIN LOCK
Ho8 SAFETY LOCK PIN
Hog S/1. FETY LOCK SPRING
Hw SA FETY LOCK .SET SCREW PIN
H11 SYNTHETIC MAIN RECEIVER
H12 CARTRIDGE LIFTER LOCK SPRING
H13 CARTRIDGE LIFTER LOCK PIN (SYNTHETIC MODEL)
H14 HAND GRIP BUTTOM COVER
H15 HAMMER HOLDER
H16 MAGAZIN LOCK PIN
H17 HAMMER HOLDER SPRING
H18 MAGAZIN LOCK I BUTTON SPRING
H19 MAGAZINE LOCK I BUTTON
H20 MAIN RECEIVER PINS
H21 TRIGGER SPRINGS
H22 TRIG GER
H23 INSIDE RI GGER
H24 HAMMER SPRING
H25 HAMMER

STOCK SETS & MAGAZINE PARTS

P01 BUTT PAD
P02 STOCK MAIN SCREW
P03 REMOVEABLE STOCK
P04 ASSEMBLY SCREW NUT
P05 BUTT PAD FIXING SCREW
P06 SLING SWIVEL NUT SCREW
P07 SLING SWIVEL NUT PIN
P08 SLING SWIVEL AREA
P09 MONOBLOCK BUTTOM RECEIVER (SYNTHETIC MODEL)
P10 FOREARM (SYNTHETIC MODEL)
P11 ALUMINIUM FOREARM UPPER PART
P12 REMOVEABLE SIDE PICATINNY
P13 PICATINNY NUTS
PM PICATINNY FIXING SCREW
P15 BARREL ASSEMBLY NUTS LOCKING EQUIPMENTS
P16 BARREL ASSEMBLY NUTS
P17 BARREL ASSEMBLY NUTS LOCKING EQUIPMENTS (ALUMINIUM FOREARM MODEL)
P18 BARREL ASSEMBLY NUTS (ALUMINIUM OR ARM MODEL)
P19 SLING SWIVEL NUTS
P20 ALUMINIUM FOREARM ASSEMBLY NUTS
P21 ALUMINIUM FOREARM BUTTOM PART
P22 MAGAZINE SIDE EXTRACTOR SPRING
P23 MAGAZINE SIDE EXTRACTOR NUT
P24 MAGAZINE SIDE EXTRACTOR
P25 MAGAZINE UPPER PLUG
P26 2RD MAGAZINE

P27 SRD MAGAZINE
P28 10RD MAGAZINE
P29 2RD MAGAZINE SPRING
P30 5RD MAGAZINE SPRING
P31 10RD MAGAZINE SPRING
P32 MAGAZINE BUTTOM PLUG LOCK NUT
P33 MAGAZINE BUTTOM PLUG

BARREL AND ASSEMBLY EQUIPMENT PARTS

T01 UP RECEIVER
T02 BARREL LUG
T03 BARREL
T04 OOR BUSJER
T05 BIG PISTON
T06 BIG PISTON ORING
T07 LINK TUBE (SYNTHETIC FOREARM MODEL)
T08 MAIN SPRING (SYNTHETIC FOREARM MODEL)
T09 UPPER PART (SYNTHETIC FOREARM MODEL)
T10 ASSEMBLING NUT (SYNTHETIC FOREARM MODEL)
T11 MAIN SPRING (ALUMINIUM FOREARM MODEL)
T12 LINK TUBE (ALUMINIUM FOREARM MODEL)
T13 SMALL PISTON
T14 SMALL PISTON ORING
T15 GAS DISCHARGE VALVE NUT
T16 SLING SWIVEL NUT
T17 ASSEMBLING NUT

STORAGE

Clean thoroughly and oil your gun before storage. Store the gun in a case to prevent scratches and dents.

Store in a dry place to prevent corrosion. Store the gun away from children and in place where it cannot be obtained by those unauthorized to use it. Always store gun unloaded and separately from any ammunition.

IMPORTANT

USAGE OF STEEL SHOT

The choke (bore constriction) in all modern shotguns has been established based on the pattern performance of shot shells loaded with lead shot. When using the steel shot shells, you will notice a different performance in pattern density versus the established lead shot pattern, because the steel shot is harder and lighter than lead shot.

You should be aware of the following differences and cautions: Never shoot steel shot loads in a full choked barrel or full choke tubed barrel. To do so may cause the barrel to swell or rupture. In general, steel shot fired with a modified choke will produce the equivalent of a lead full choke pattern. This will be true of all steel shot sizes up to and including no. 2. The established improved cylinder chokes will produce the equivalent of a (lead) modified choke pattern. All steel shot sized larger than no. 2, and including special sized such as -F-, "T", etc., should be used only with improved cylinder chokes. These steel shot sized, when used in improved cylinder chokes, will produce patterns equivalent to (lead) full choke patterns. The established cylinder choke or bore will produce the equivalent of a modified (lead) pattern. Additional information concerning the use of steel shot is available from Remington, Winchester, Federal and other ammunition companies.

PARTS

To order parts, please furnish the following information: Your name, address, telephone number, firearm serial number, make and model. When we receive your request we will send you an order form and a parts breakdown with prices.

MAINTENANCE AND CLEANING

Caution: Make sure the gun is unloaded.

1. Make sure that the broad, polished, finely fitted mating surfaces of the breech block and receiver are especially clean and lightly oiled with a high quality gun oil. Do not use pure silicone or lanolin.
2. Run an oil patch through the bore with a cleaning rod starting from the breech end. To prevent leading, use a cleaning solvent and brass brush to clean the bore periodically. Follow this cleaning with one or two clean oil patches. Important: If your gun is equipped with choke

tubes, do not use a brass brush to clean the barrels unless a choke tube is installed in **each** barrel. Barrels that utilize choke tubes must also have the choke tubes removed to clean and oil the threads inside the barrel and the choke tubes themselves. This will protect the threads from being damaged by cleaning tools and also prevent a dirt build up that would cause the choke tube to become difficult to remove from the barrel. Damage can result to choke tubes and barrel when attempting to remove sticky choke tubes.

Never fire your gun without choke tubes snugly tightened in barrels. Do not over tighten choke tubes. Wipe all exposed metal surfaces with an oiled cloth before storing.

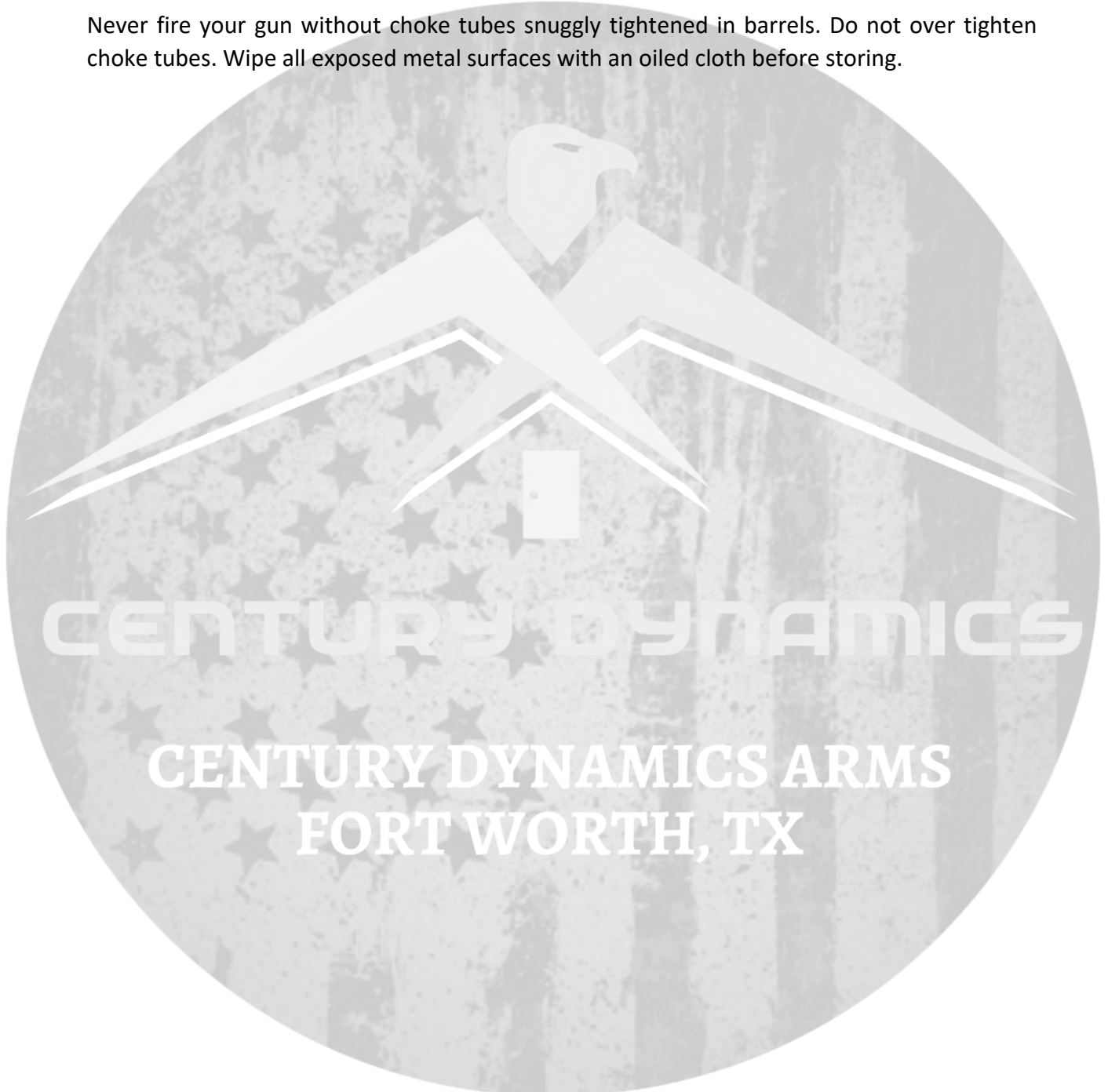

WARRANTY CARD

PURCHASER _____

Street _____

City _____ State---Zip-----

Phone _____

Purchase Date _____

PRODUCT: Model Gauge____ Serial # _____

SIGNATURE _____
CENTURY DYNAMICS ARMS
FORT WORTH, TX

Please sign and return this card to validate warranty



CENTURY DYNAMICS

CENTURY DYNAMICS ARMS

WWW.CENTURYDYNAMICS.COM

FORT WORTH, TX, USA

817-210-6086

SALES@CENTURY-DYNAMICS.COM

**CENTURY DYNAMICS ARMS
FORT WORTH, TX**