

CUSTOM SIZES AVAILABLE

CONTACT CBP FOR GLAZING TYPES AND SIZE RESTRICTIONS

(Mullions may be required for window sizes over 63" x 89-1/4")

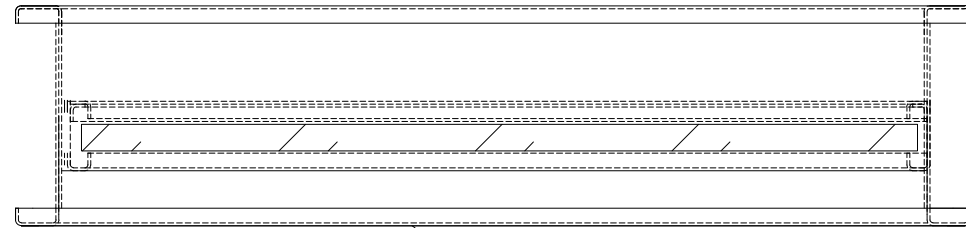

BULLET RESISTANT FRAME

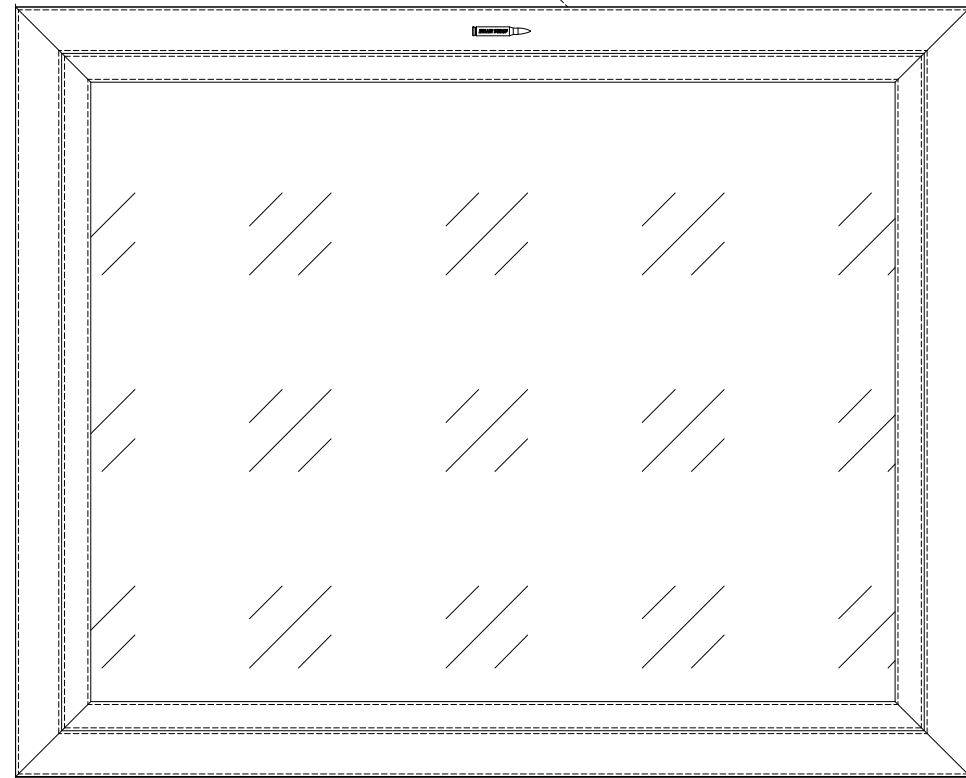

THREAT SIDE ELEVATION

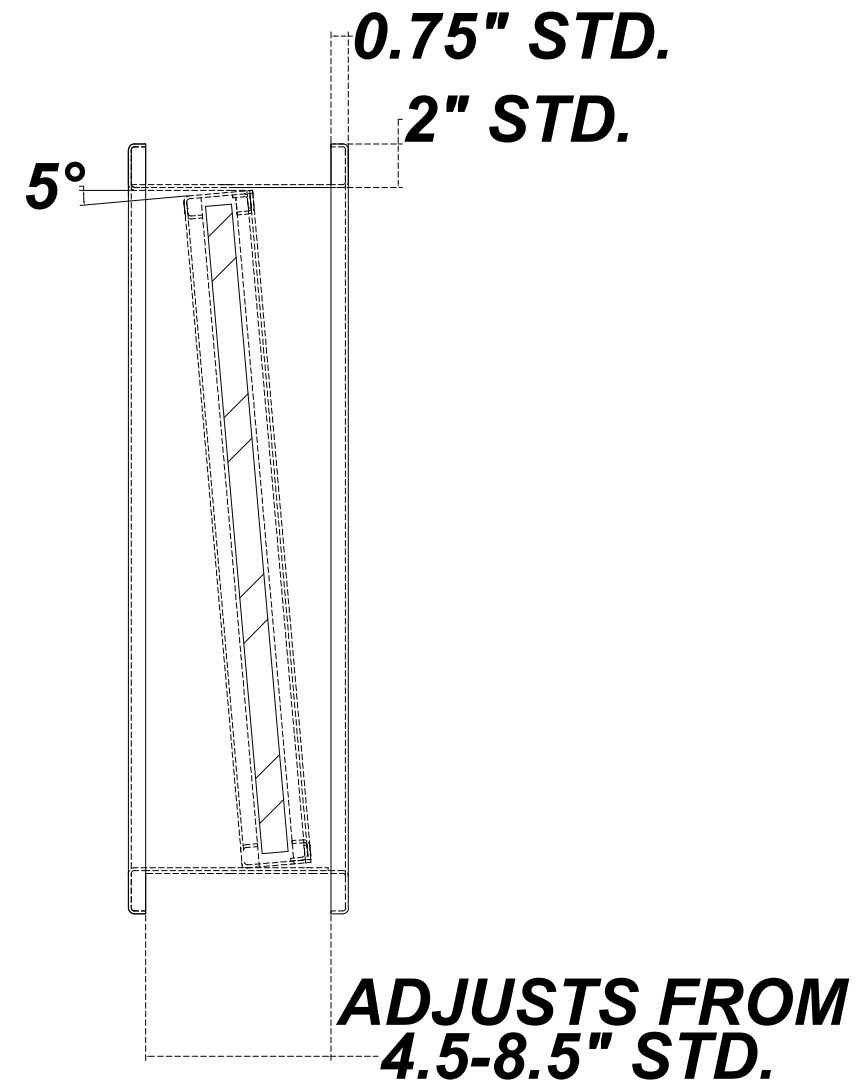
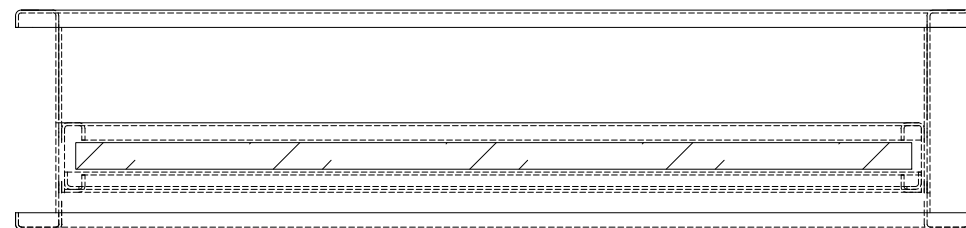

CBP Model CV

Bullet Resistant Clamp-on Drive-up/Observation Window

UL 752 Listed and Labeled Levels 1-4, & 6
(A label bearing certification is affixed to the protected side of the frame)

**MODEL CV CLAMP-ON
DRIVE-UP/OBSERVATION WINDOW
DESIGN FEATURES SUBFRAME FOR
GLAZING INCLINED 5° TO VERTICAL TO
REDUCE GLARE.**

FILE NO. BP1942 SECURITY					
		CHICAGO BULLET PROOF SYSTEMS, INC. 2595 BOND ST. UNIVERSITY PARK, IL. 60484 708-534-9102 WWW.CHICAGOBULLETPROOF.COM			
		CV WINDOW			
MATERIAL: SHOT-TEX		FINISH: PRIME PAINTED, CUSTOM FINISH PAINT, OR STAINLESS STEEL			
DWG. NO.: CV	REVISION: 0	UL LEVEL: 1-4, & 6	GLAZING: TBD	TOLERANCES: +/-1/16"	SCALE: 1-1
SHEET: 1 OF 1	WEIGHT: TBD				