

# CUSTOM SIZES AVAILABLE

## CONTACT CBP FOR GLAZING TYPES AND SIZE RESTRICTIONS

(Mullions may be required for window sizes over 61-1/2" x 85-1/2")

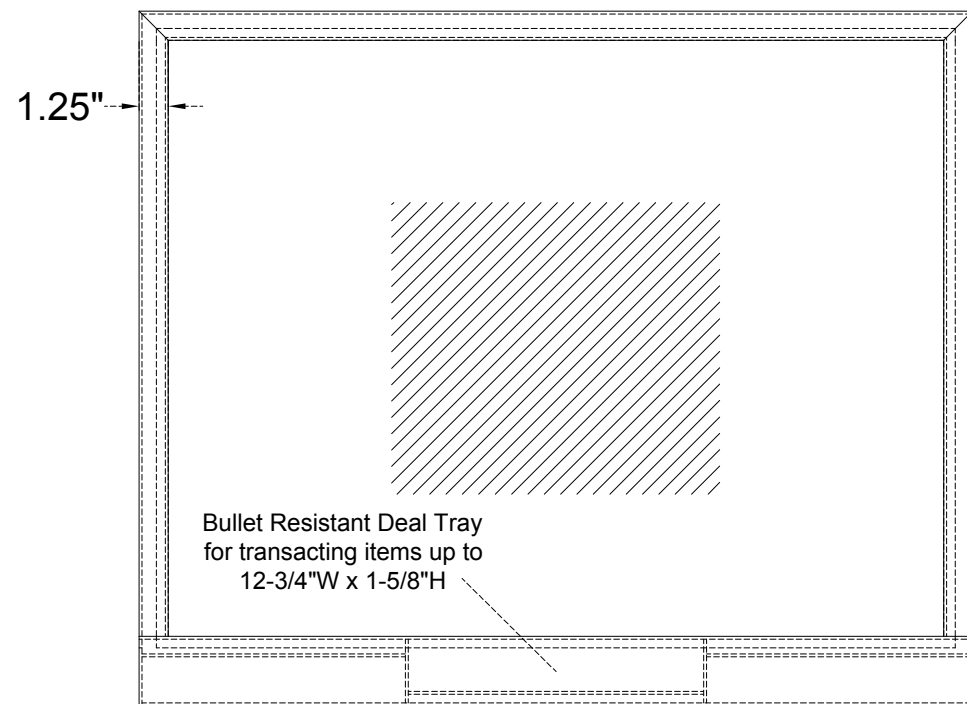
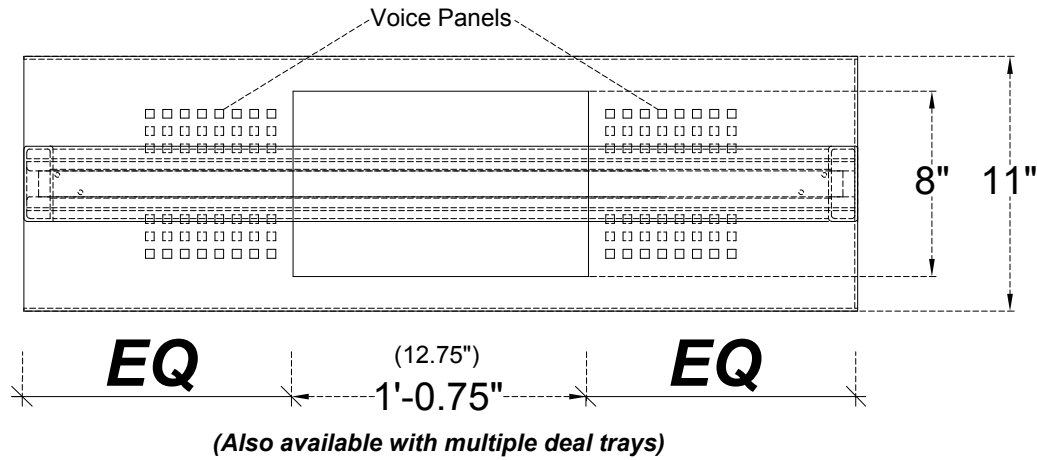

**ELEVATION**

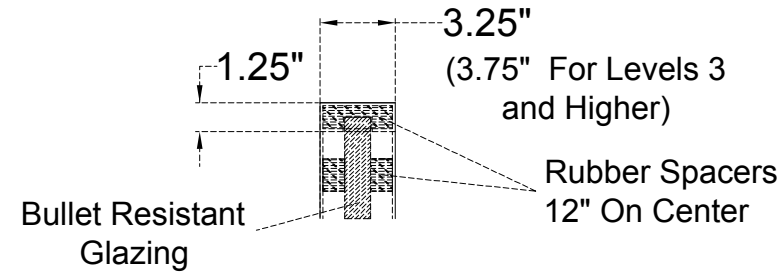

**HEAD/JAMB SECTION**

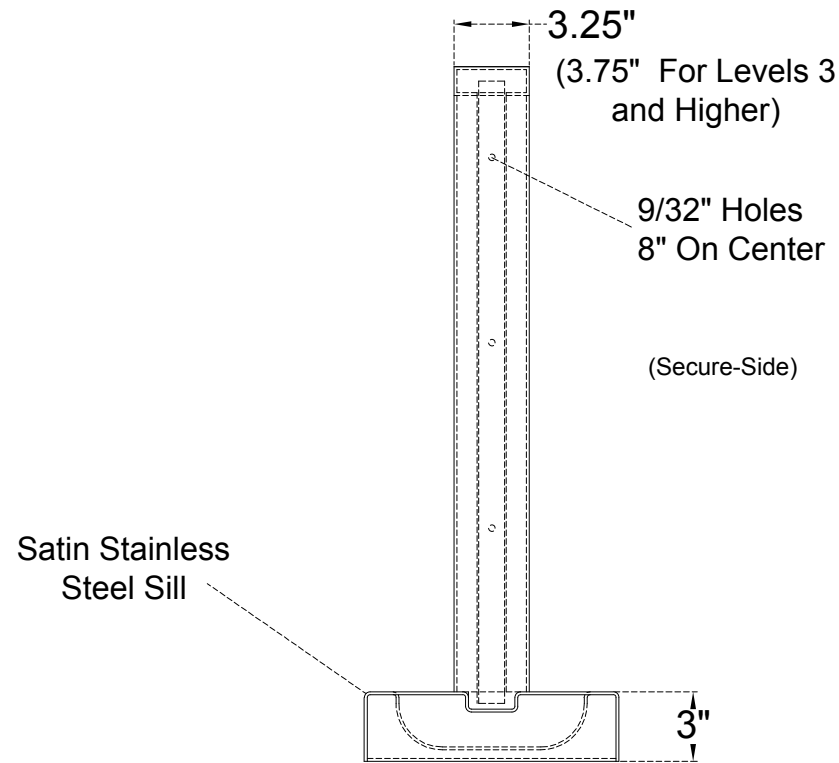

**END VIEW**

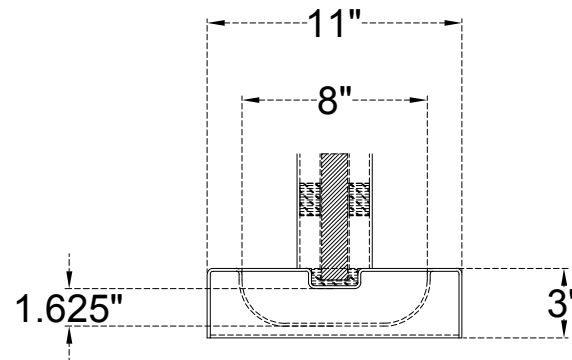

**SILL SECTION**

# CBP Model NTW

Bullet Resistant Narrow Profile Transaction Window

UL 752 Listed and Labeled Levels 1-4, & 6  
(A label bearing certification is affixed to the protected side of the frame)

Note: CBP Model NTW features a voice panel sill and rubber spacers to create an acoustically balanced natural voice transmission system. Sealants or glazing compounds are not to be used to close gaps between the bullet resistant glazing product and the framing assembly, this will inhibit the natural voice transmission capability.

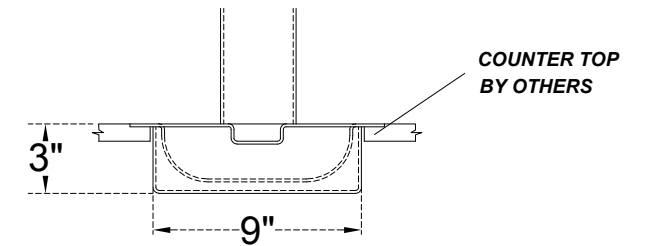

**OPTIONAL MORTISE SILL SECTION**

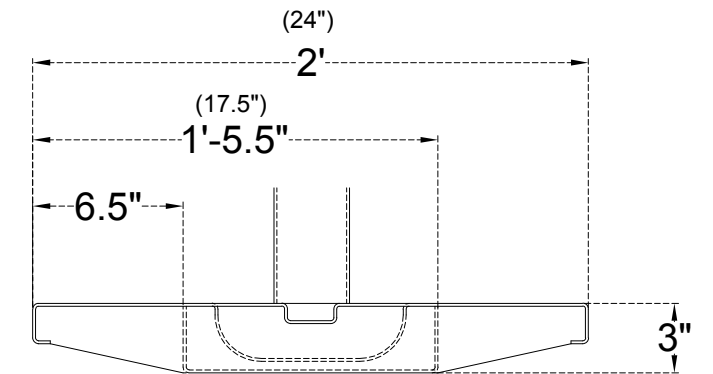

**OPTIONAL 6-1/2" STAINLESS STEEL WRITING LEDGE SECTION**

-Extends the full width of the sill

-Available on either or both sides of window

FILE NO. BP1942  
SECURITY

CHICAGO BULLET PROOF SYSTEMS, INC  
2595 BOND ST. UNIVERSITY PARK, IL. 60484  
708-534-9102  
WWW.CHICAGOBULLETPROOF.COM

## NTW WINDOW

MATERIAL: SHOT-TEK		FINISH: PRIME PAINTED, POWDER COATED, OR STAINLESS STEEL			
DWG. NO.: NTW	REVISION: 0	UL LEVEL: 1-4, & 6	GLAZING: TBD	TOLERANCES: +/-1/16"	SCALE: 1-1
SHEET: 1 OF 1	WEIGHT: TBD				