

Quicklub® Lubrication Systems

Introduction to Quicklub®



The Lincoln Quicklub system is designed to provide a relatively simple and inexpensive method of centralizing or automating the lubrication of machinery bearings.

Quicklub can be a simple, centralized system with lubricant supplied manually from a lever gun. Pre-assembled kits are available to service up to 12 points from a single grease fitting. Custom kits can also be provided by our distributors to cover virtually any quantity of points desired.

Quicklub® lubrication method

A Quicklub® centralized lubrication system typically dispenses measured amounts of lubricant to each point covered by the system. Even those hard to reach are assured of being properly lubricated and purged of contaminants.

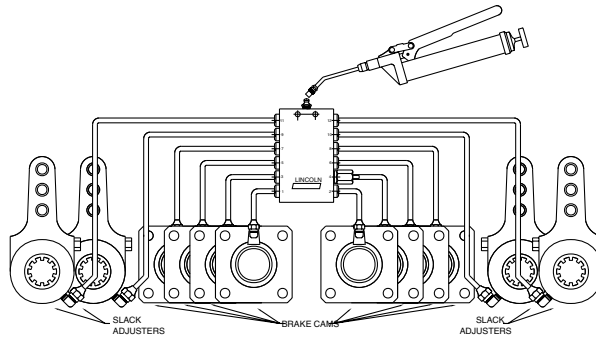

System Operation

1. The lubricant is delivered to the divider valves through a hand- or air-operated grease gun.
2. The divider valve dispenses lubricant in measured amounts directly to each point being covered by the system through the feedlines. Visual indication of cycle pin assures that all points are lubricated.

Quicklub can also be a fully automated system with lubricant supplied by our 12VDC and 24VDC electric or pneumatic pumps. An automated lubrication system typically dispenses small measured amounts of lubricant at frequent intervals while production machines are operating. The electric pumps incorporate an integrated timer for easy installation and trouble-free operation.

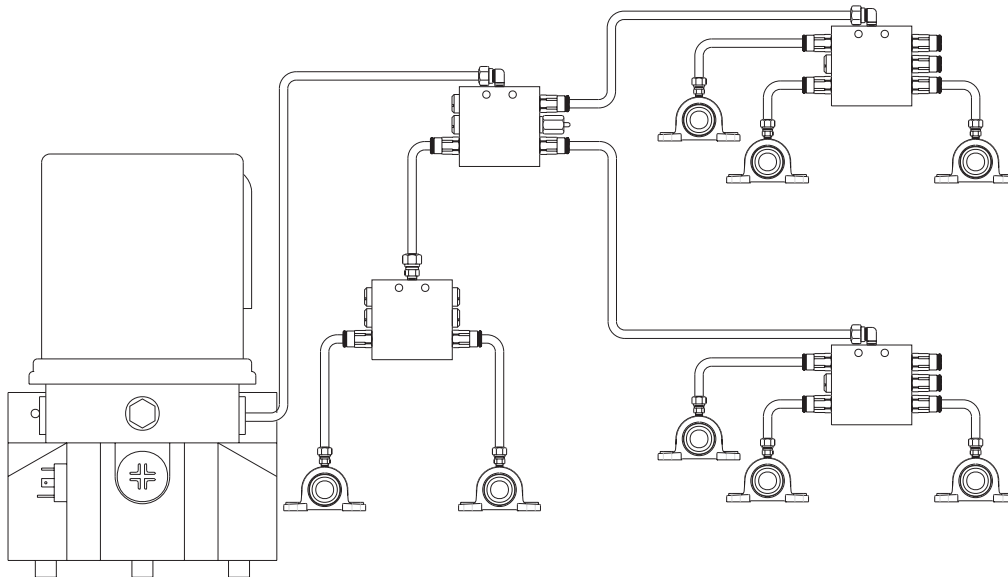

Quicklub systems have proven to be the right solution for many industries and applications, eliminating costly, manual point-by-point lubrication. Examples include:

Mobile Equipment

- Over-the-road tractors
- Single-axle trailers
- Tandem-axle trailers
- Tri-axle trailers
- Yard tractors
- Trucks of all types
- Refuse haulers
- Wheel loaders
- Hydraulic excavators
- Motor graders
- Backhoe loaders
- Hydraulic hammers
- Street sweepers
- Road & highway paving equipment

Industrial Equipment

- Packaging
- Lathes
- Beverage industry
- Textile
- Metal working
- Wood processing
- Material handling equipment
- Bakery
- Printing
- Punch presses
- Paper converting
- Milling
- Plastic processing

The heart of the Quicklub® system

More than a drilled manifold block, the valve incorporates a series of metering pistons which accurately dispense lubricant from each outlet, overcoming back pressure of up to 1,000 psi. Visual monitoring is provided with an indicator pin, which confirms a valve has completed a full cycle. Quicklub divider valves are available for grease or oil applications and in carbon steel and 303 stainless steel for corrosive environments.

Figure 1

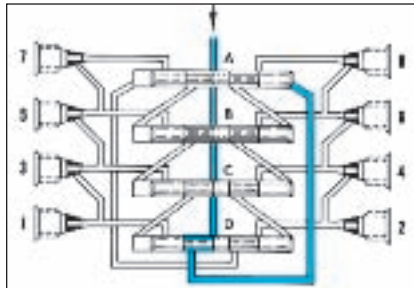

Figure 2

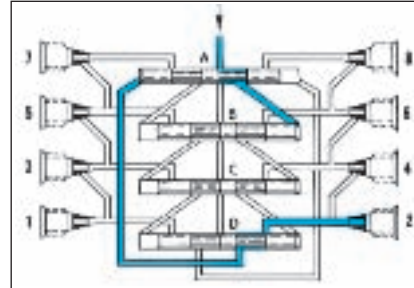

Figure 3

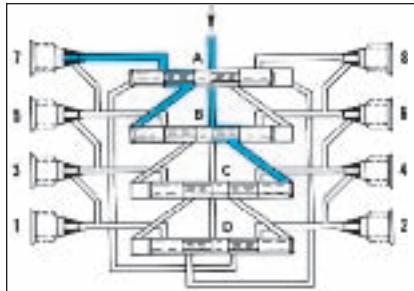
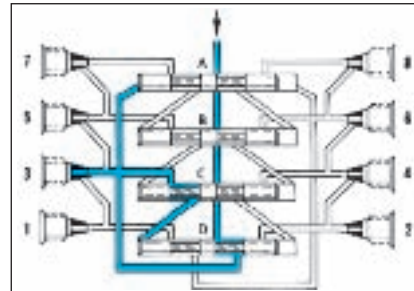

Figure 4



The inlet passageway is connected to all piston chambers at all times with only one piston free to move at any time.

- With all pistons at the far right, lubricant from the inlet flows against the right end of piston A (fig. 1).
- Lubricant flow shifts piston A from right to left, dispensing lubricant through connecting passages to outlet 2. Flow is then directed against the right side of piston B (fig. 2).
- Piston B shifts from right to left, dispensing lubricant through outlet 7. Lubricant flow is directed against the right side of piston C (fig. 3).
- Piston C shifts from right to left, dispensing lubricant through outlet 5. Lubricant flow is directed against the right side of piston D.
- Piston D shifts from right to left, dispensing through outlet 3. Piston D's shift directs lubricant through a connecting passage to the left side of piston A (fig. 4).

Lubricant flow against the left side of piston A begins the second half-cycle, which shifts pistons from left to right, dispensing lubricant through outlets 1,8,6 and 4 of the divider valve.

Crossporting a divider valve

Outputs from adjacent outlets may be combined by installing a closure plug in one or more outlets. Lubricant from a plugged outlet is redirected to the next adjacent outlet in descending numerical order. Outlets 1 and 2 must not be plugged since they have no cross-port passage to the next adjacent outlet.

In figure 5, outlets 5 and 3 are cross-ported and directed through outlet 1. In this example, outlet 1 will dispense three times as much lubricant as outlet 7. The tube ferrules in outlets 1 and 7 block the cross-port passage so that lubricant flow is only directed through outlets.

Figure 5

