

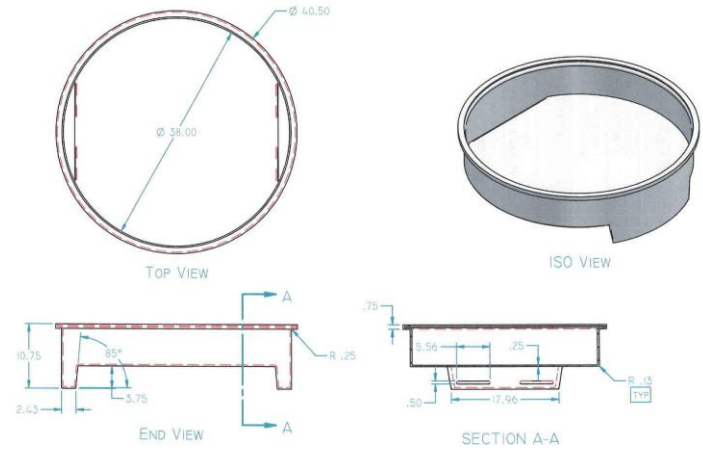

Zena - Bird Nest

“ The Hollonest”

The Zena Bird Nest - encourages the birds to use the nest rather than building their own on the power line structures. Moving the birds away from the unsafe, and sensitive areas, effectively lowers the risks of avian electrocution, insulator and streamer flashovers, structure corrosion and bird strikes.



The nest is cross ribbed for extra strength and also has drainage points on two sides



Features

Designed specifically for osprey and larger birds, the Zena Hollonest: (Available in Gray or Black)

- Is bird safe and environmentally friendly,
- Installs quickly, reducing downtime,
- Has excellent self-washing characteristics
- Is stackable – for storage & transportation

Application

The Zena Hollonest is shipped stacked & ready to mount on wooden & concrete poles, as well as steel structures within minutes. It is molded using proprietary high-density polyethylene that is contaminant and weather-resistant, and is fixed to the structure using (optional) **Stainless Steel brackets** or **Stainless Steel banding**.



For More Information

To learn more about how our products and services could help your organization, please contact us.

Call: (970) 663-3980

Fax: (970) 663-3972

Email: info@zenadesign.com

Visit: www.zenadesign.com