

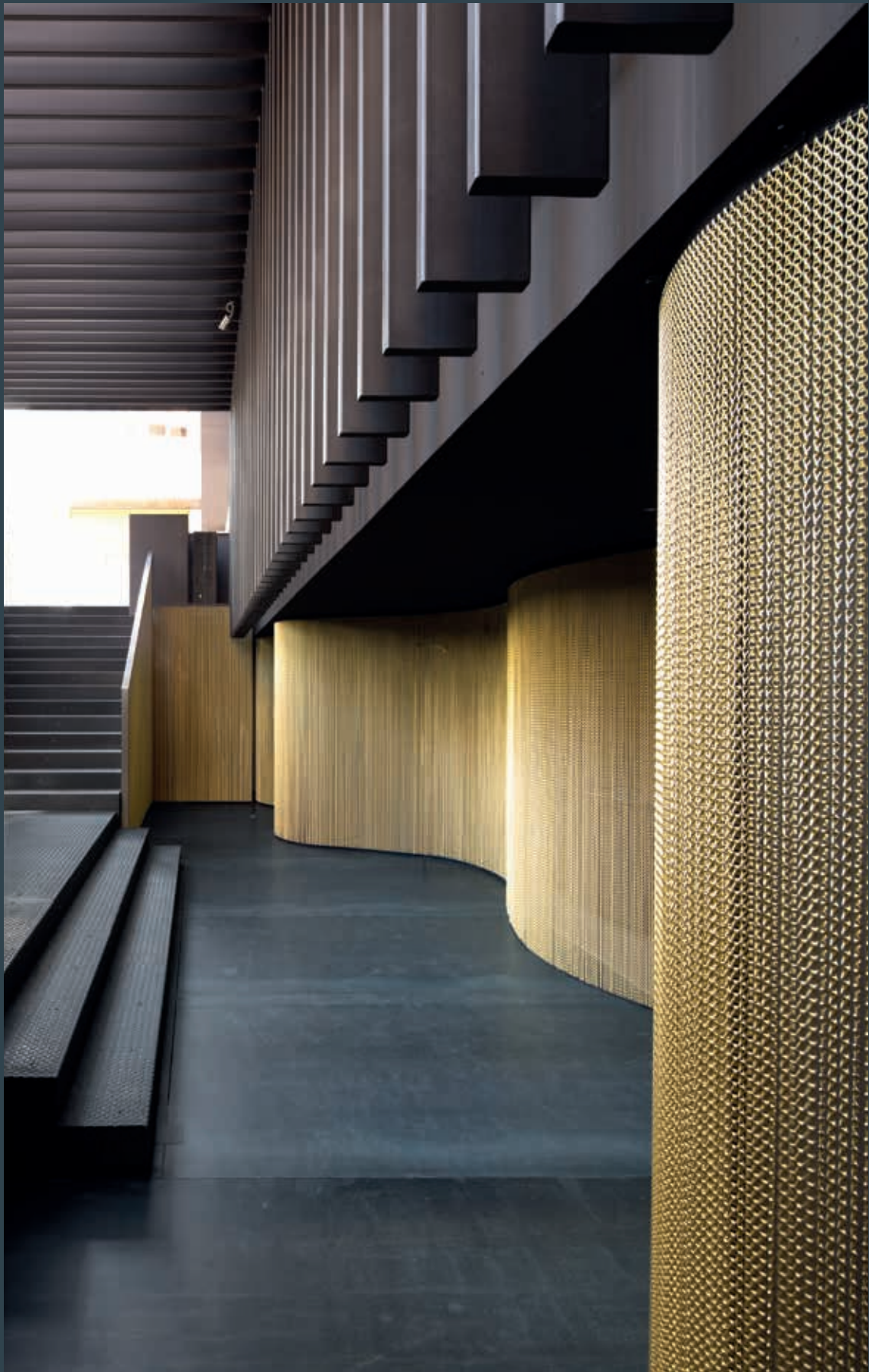

**kriskadecor** 

linking  
ideas





Canalla Discotheque by Vaillo+Irigaray Architects. Photo by Rubén Pérez Bescós

We do chain art. We create highly customized projects made with anodised-aluminium links, a light and versatile material. Our brand offers a wide range of solutions for architects and interior designers: space dividers, wall covering, ceiling, façades, lighting structures and special design projects.

Customization is Kriskadecor's most strong value. We develop projects based in colours, shapes and volumes following customers' needs and desires. Thanks to our patented technology, we are able to reproduce images and patterns combining a wide range of colours in brilliant and satin finishes.

Innovation and customer's service have also been the core values of our company since it was created in 1926. Still a family-run company with the third generation leading the company nowadays, the spirit of the grandfather and founder, Josep Maria Sans Amill still remains and as he used to say:

“THERE IS NOTHING THAT CAN'T BE DONE, ONE JUST HAS TO FIND THE WAY”

Kriskadecor has two headquarters placed in Montblanc, Spain and in Phoenix, USA. At present the brand exports to more than 50 countries.

Hacemos arte con cadena. Creamos proyectos completamente personalizados hechos con nuestros eslabones de aluminio anodizado, un material ligero y versátil. Nuestra marca ofrece una amplia variedad de soluciones tanto para arquitectos como para diseñadores de interiores: separación de espacios, paredes, techos, recubrimientos de exterior, estructuras especiales y de iluminación en proyectos de diseño contract.

La personalización es uno de nuestros rasgos más importantes. Desarrollamos proyectos basados en colores, formas y volúmenes siguiendo los deseos y necesidades de nuestros clientes. Gracias a nuestra tecnología patentada podemos reproducir imágenes y diseños combinando una amplia variedad de colores en acabados brillantes y satinados.

La innovación y el servicio al cliente han sido los principales valores de la compañía desde que fue fundada en 1926. Kriskadecor sigue siendo una empresa familiar, con la tercera generación al frente, donde el espíritu del abuelo y fundador, Josep Maria Sans Amill, todavía permanece y como él solía decir:

“NO HAY NADA QUE NO SE PUEDA HACER, SÓLO HAY QUE ENCONTRAR LA MANERA”

Kriskadecor cuenta con dos sedes, la sede central en Montblanc (España) y otra en Phoenix (Estados Unidos). Actualmente, la marca exporta a más de 50 países.

# The link / El eslabón

## Kriska



The original trademarked metal link.  
Versatile and resistant.

El eslabón original patentado.  
Versátil y resistente.

## Snina



The delicate one. For more defined  
and smart chain artworks.

La opción delicada. Para proyectos  
más definidos y delicados.

## Densities / Densidades

### Standard

The perfect symmetry. Chain strands harmonically  
aligned. Suitable for most uses.

La simetría perfecta. Líneas de cadena  
harmónicamente alineadas. Adecuada para la  
mayoría de usos.

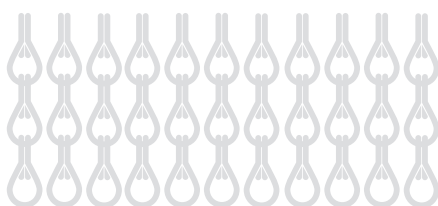

**Kriska:** 78 strands per linear meter of rail.  
78 tiras por metro lineal de rail.

**Snina:** 100 strands per linear meter of rail.  
100 tiras por metro lineal de rail.

### Half-drop

The intense option. Half-drop density provides  
higher opacity and a stronger visual impact.

La opción más intensa. La densidad half-drop  
aporta una mayor opacidad e impacto visual.

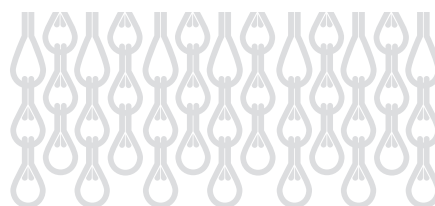

**Kriska:** 100 strands per linear meter of rail.  
100 tiras por metro lineal de rail.

**Snina:** 132 strands per linear meter of rail.  
132 tiras por metro lineal de rail.

## Colours / Colores

It is possible to combine our metal links in  
brilliant and satin finishes for both Kriska  
and Snina.

Es posible combinar nuestros eslabones metálicos  
en acabados brillantes y satinados tanto en Kriska  
como Snina.

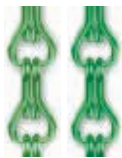

**Black**Brilliant / Brillante  
20011Satin / Satinado  
20211**Grey**Brilliant / Brillante  
20012Satin / Satinado  
20212**Coffee**Brilliant / Brillante  
20021Satin / Satinado  
20221**Brown**Brilliant / Brillante  
20006Satin / Satinado  
20206**Sand**Brilliant / Brillante  
20028Satin / Satinado  
20228**Apricot**Brilliant / Brillante  
20020Satin / Satinado  
20220**Orange**Brilliant / Brillante  
20013Satin / Satinado  
20213**Gold**Brilliant / Brillante  
20003Satin / Satinado  
20203**Lime**Brilliant / Brillante  
20017Satin / Satinado  
20217**Emerald**Brilliant / Brillante  
20008Satin / Satinado  
20208**Moss**Brilliant / Brillante  
20027Satin / Satinado  
20227**Green**Brilliant / Brillante  
20004Satin / Satinado  
20204**Silver**Brilliant / Brillante  
20001Satin / Satinado  
20201**Nickel**Satin / Satinado  
20214**Amethyst**Brilliant / Brillante  
20026Satin / Satinado  
20226**Pale Pink**Brilliant / Brillante  
20024Satin / Satinado  
20224**Pink**Brilliant / Brillante  
20010Satin / Satinado  
20210**Florida Pink**Brilliant / Brillante  
20016Satin / Satinado  
20216**Bordeaux**Brilliant / Brillante  
20018Satin / Satinado  
20218**Red**Brilliant / Brillante  
20005Satin / Satinado  
20205**Lilac**Brilliant / Brillante  
20007Satin / Satinado  
20207**Blue**Brilliant / Brillante  
20002Satin / Satinado  
20202**Cobalt**Brilliant / Brillante  
20029Satin / Satinado  
20229**Turquoise**Brilliant / Brillante  
20009Satin / Satinado  
20209

*NOTE: Colours may vary between the catalogue and the final product supplied due to lighting effects or the printing process of the catalogue.*  
*NOTA: Los colores pueden variar en relación a los mostrados en este catálogo debido a la impresión y/o los posibles efectos de iluminación.*

# Customization / Personalización

Every project is unique, that is why we think about every single detail to adjust it to our clients' needs and desires.

Cada proyecto es único, por eso pensamos en cada pequeño detalle para ajustarnos a los deseos y necesidades de nuestros clientes.

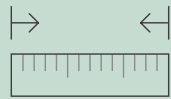

Sizes / Medidas



Colour and image /  
Color e imagen

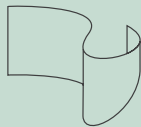

Shapes and volumes /  
Formas y volúmenes



Sizes / Medidas

From the smallest and most delicate to the most majestic and large aluminium chain projects, each one will be developed and taken care of from the very beginning to the end.

Desde el más pequeño al más grande, cada proyecto se desarrolla con total atención, siguiendo cuidadosamente las especificaciones de nuestros clientes.



Small projects / Proyectos pequeños  
*Nieva de noche* by Claire Davies.



Large structures / Grandes estructuras  
*Ecuador Pavilion at Milan Expo* by Zorroza y Asociados.



## Colour and image / Color e imagen

We know a picture is worth a thousand words. And we found the way to translate all these emotions through our own patented technology so we can reproduce any picture, pattern or corporate design in which every link acts as a pixel. It is also possible to use designs from our Collection's catalogue or just a solid colour.

Sabemos que una imagen vale más que mil palabras, por eso hemos desarrollado nuestra propia tecnología patentada que nos permite trasladar las emociones al diseño de interiores y proyectos arquitectónicos. Podemos reproducir imágenes, diseños de estampados o logos corporativos en los que cada eslabón actúa como un píxel. También disponemos de carta de colores y nuestro catálogo Collection.

### Customization / Personalización



Original / Original



Preview / Vista previa



Final result / Resultado

### Collection's Catalogue / Catálogo Collection

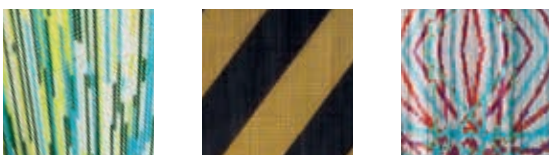
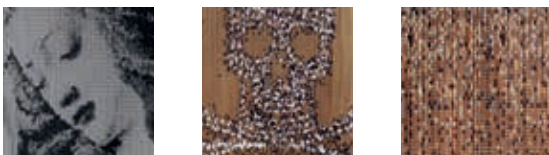

### Colours / Colores



## Shapes and volumes / Formas y volúmenes

The limit is everyone's imagination. We can even materialise ideas in 3D volume with defined shapes.

El límite está en la imaginación de cada uno. Y nosotros podemos materializar esas formas incluso en 3D.

### SHAPE / FORMA

From the defined shape set on the project, we can develop a rail or structure that fits into the requirements

Partiendo de la forma definida en el proyecto, podemos desarrollar un rail o estructura que se ajuste a los requerimientos.



### SURFACE / SUPERFICIE

In order to define the surface, the chains can be straight, they can define a shaped form or they can even be fixed to the ceiling by both ends.

Para definir la superficie, las cadenas pueden seguir formas rectas, se pueden definir vaciados e incluso se pueden fijar al techo por ambos extremos.



### VOLUME / VOLUMEN

It is possible to develop 2D or 3D volumes with the desired density and chain's distribution.

Es posible desarrollar volúmenes en 2D o 3D con la densidad y distribución de cadenas deseadas.







Design  
solutions /  
Soluciones  
de diseño

# Space dividers / Separación de espacios

Fixed / Fijas



Straight /  
Rectas



Undulated/  
Onduladas



Curved/  
Curvas

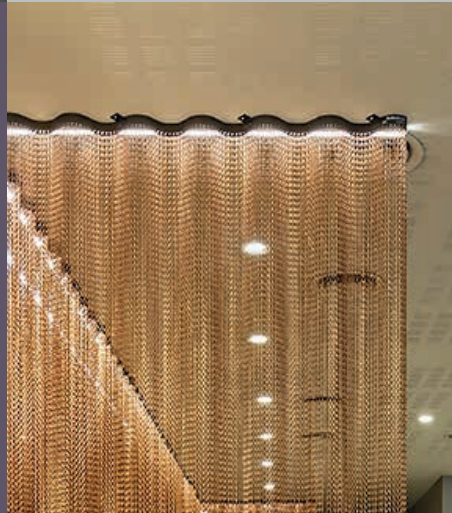

**Straight:** Aquaknox - Venetian Hotel by Studio DW **Curved:** Le Méridien Ra Beach Hotel & Spa by ds.architectes.  
Photo by Eric Cuvillier / **Undulated:** Kurtz&Gutz Restaurant by Pler Interioristas. Photo by Marcela Grassi.



Customized partition walls or space dividers with straight, curved or undulated shapes combined with fixed or mobile systems, which can reproduce images and patterns to create dramatic atmospheres.

Separadores de espacios totalmente personalizados con formas rectas, curvas u onduladas, que pueden combinarse con sistemas fijos y móviles, así como reproducir imágenes y diseños para crear atmósferas sorprendentes.

## Mobile / Móviles



**Mobile system /  
Sistema móvil**



**Sliding panel system /  
Panel japonés**

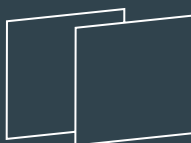

# Wallcovering / Paredes

Covering a wall with a mobile or fixed system has never been so exciting. There is a technical solution for every space, the size or the shape does not matter.

Cubrir una pared con un sistema fijo o móvil nunca había sido tan interesante. Hay una solución técnica para cada espacio sin importar la medida o la forma.

## Fixed or mobile / Fijas o móviles

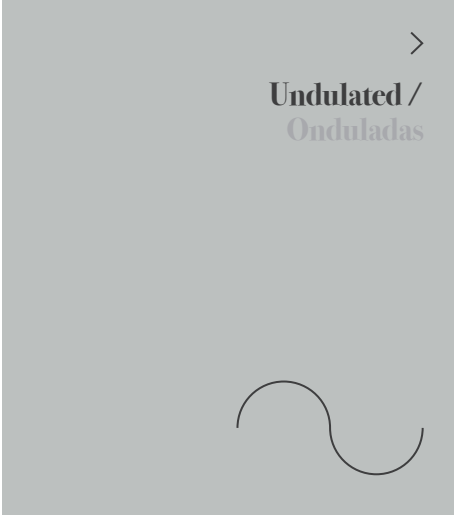
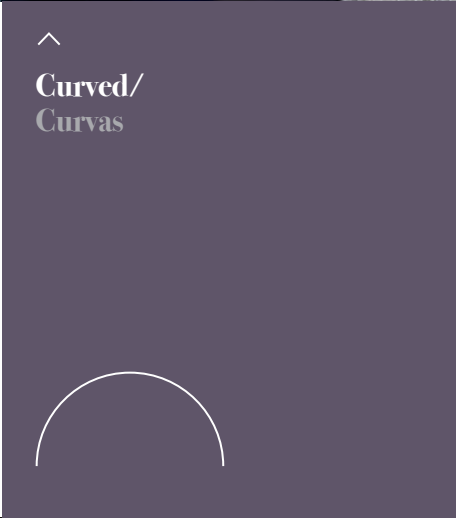

**Straight:** ARN Restaurant by Studio Yaron Tal / **Curved:** Elorin Offices by Gaz arquitectos. Photo by Iñaki Eskubi / **Undulated:** Cosmopolitan Casino's Concierge area by Rockwell Group

# Ceilings / Techos

This architectural solution makes possible creating textures and surprising shapes on ceilings. It is even possible to recreate a rainy effect. From elegant waves or parallel structures to amazing artistic figures and volumes, Kriskadecor can develop very large ceiling solutions.

Esta solución arquitectónica permite crear texturas y formas sorprendentes en techos. Incluso es posible recrear un efecto de lluvia. Desde elegantes ondas o estructuras paralelas hasta figuras artísticas y volúmenes, Kriskadecor puede desarrollar estructuras para techos de grandes dimensiones.

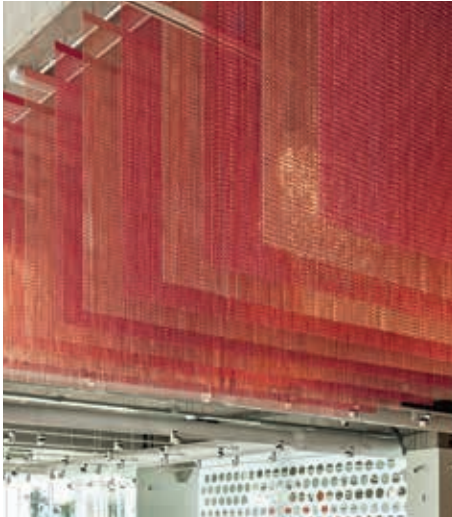

**Parallels:**  
straight or wavy /

**Paralelas:**  
rectas u onduladas

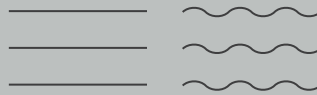

**Ceilingwaves /**  
**Ondas de techo**



**Rainy ceiling /**  
**Techo efecto lluvia**



**Concentric:**  
square or round /  
**Concéntricas:**  
cuadradas o redondas



**Parallels & Concentric:** Emocions Commercial Center by DYD interiorismo. Photo by Marcela Grassi /

**Rainy ceiling:** Talsee Showroom by Burkard Meyer Architekten & Konform / **Ceiling Waves:** Lavana Beauty Spa by Louise Nogueira.



# Cladding / Fachadas

A unique building cladding solution. Our cladding possibilities allow reproducing patterns and images. The chains reduce the entrance of sunlight but still allow vision and ventilation. Depending on the spacing, colour and inclination between 40% and 50% of the light that affects the building is reflected.

Una solución de recubrimiento única. Permite reproducir cualquier diseño o imagen. Las cadenas reducen la entrada de luz solar, pero permiten la visión y la ventilación. Además, se trata de un material ligero y de fácil instalación. Dependiendo del tipo de espaciado, color e inclinación, permite reflejar entre un 40% y un 50% de la luz que incide en la estructura.

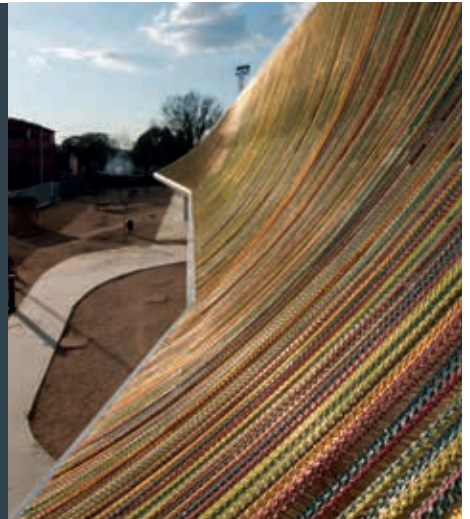

**Exterior:** Ecuador Pavilion at Milan Expo by Zorroza y Asociados. Photo by Marcela Grassi / Can Manent School by Franc Fernández, Fina Frontado & Saïda Dalmau / **Interior:** Royal Ascot Hotel Apartment by Sven Müller / Marriott Auditorium Hotel by Requena y Plaza arquitectos.

# Structures / Estructuras

## Lighting / Iluminación



The way in which the aluminium chain responds to illumination allows us to create dramatic effects, therefore broadening the decorative possibilities and chain applications (for projections, stage settings...).

La forma en que la cadena de aluminio responde a la iluminación permite crear efectos espectaculares, ampliando aún más las posibilidades decorativas y aplicaciones de la cadena (proyecciones, escenografías...).

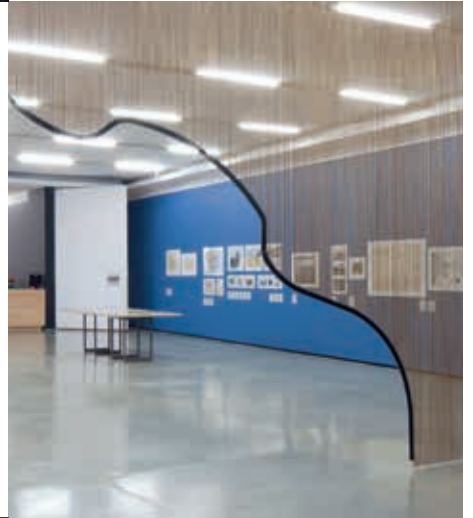

## Other structures / Otras estructuras



Special projects developed under the customers requirements to fulfill their needs and desires.

Proyectos especiales desarrollados según las especificaciones de los clientes.



**Technical  
solutions /  
Soluciones  
técnicas**



# Fixation systems / Sistemas de fijación

## Minioval

SHAPES / FORMAS

SYSTEM / SISTEMA

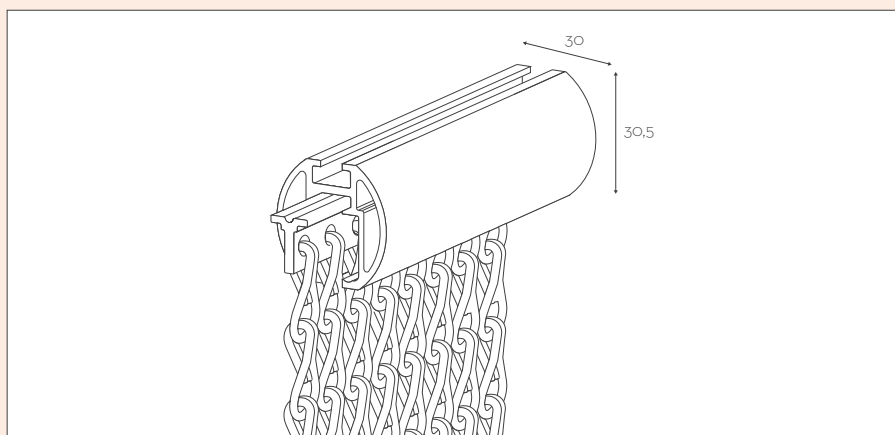

Fixed / Fijo



Mobile / Móvil



Straight / Rectas



Curved / Curvadas



Undulated / Onduladas

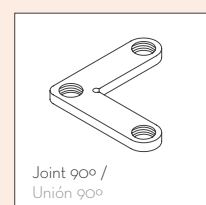
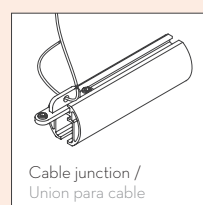
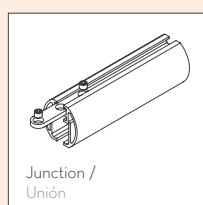
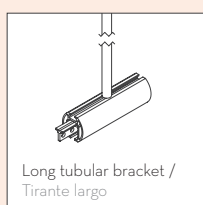
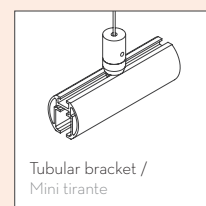
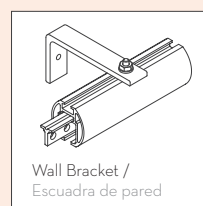
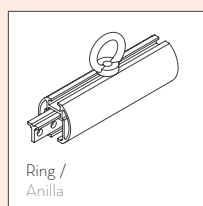
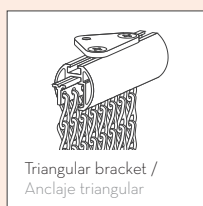
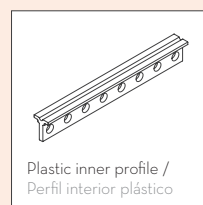
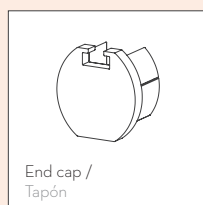

**This rounded anodized aluminium rail is the smartest option with an elegant finishing.**

**APPLICATIONS:** Ceilings or walls.

**RADIUS:** Fixed straight & curved curtains:  
min. radius of 35 cm.

**COLOUR:** Anodized aluminium.

**Este rail redondeado es la opción más elegante y delicada.**

**APLICACIONES:** Techos o paredes.

**RADIO:** Cortinas fijas rectas y curvadas:  
radio mín. 35 cm.

**COLOR:** Aluminio anodizado.

SIZES in mm

MEDIDAS en mm

**COLOUR:** Fixation systems can be lacquered in other colours under request.

**COLOR:** Los sistemas de fijación pueden lacarse en otros colores bajo petición.

# PCA

SHAPES / FORMAS

SYSTEM / SISTEMA

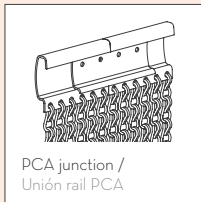
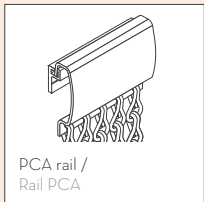
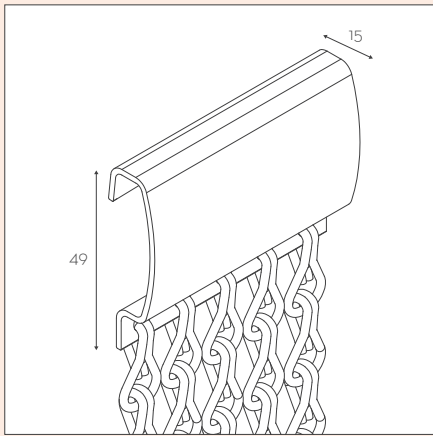

# 40x3

SHAPES / FORMAS

SYSTEM / SISTEMA

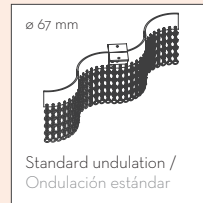
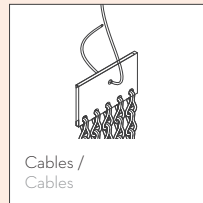
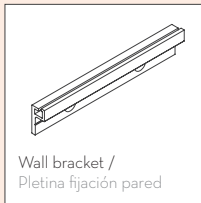
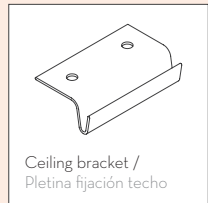
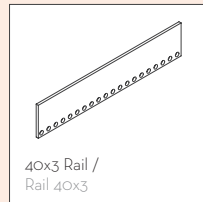
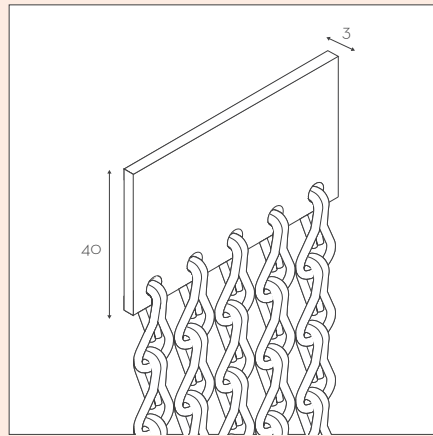

The PCA anodized aluminium rail is quick and easy to install. Mostly recommended for wall fixing.

APPLICATIONS: Ceilings or walls.

COLOURS: Anodized black / Brown / Aluminium.

Rail de aluminio anodizado de fácil instalación. Principalmente recomendado para fijación a pared.

APLICACIONES: Techos o paredes.

COLORES: Negro / Marrón / Aluminio anodizado.

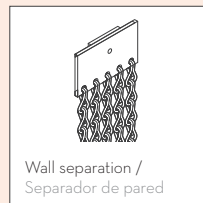

If shapes are required, this is the one.

APPLICATIONS: Ceiling or wall installation.

COLOUR: Natural aluminium.

Si se necesita crear formas, este rail es la solución adecuada.

APLICACIONES: Techos o paredes.

COLOR: Aluminio natural.

# Wall

SHAPES / FORMAS

SYSTEM / SISTEMA

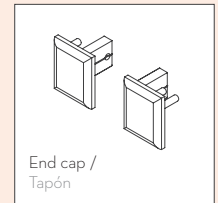
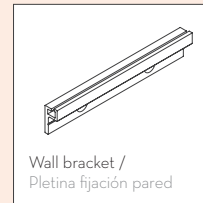
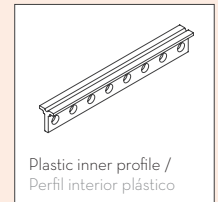
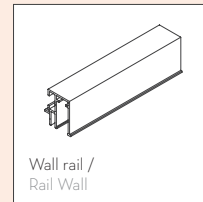
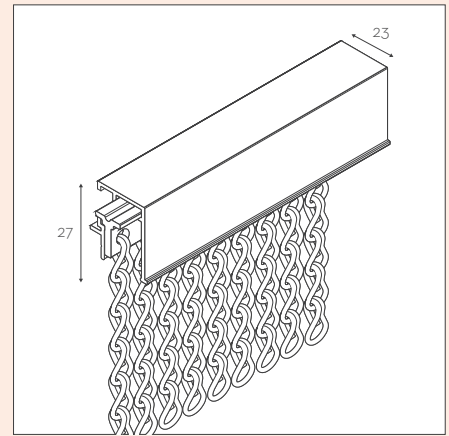

This anodized aluminium rail is specific for straight fixation to walls.

APPLICATIONS: Walls.

COLOUR: Anodized aluminium.

Este rail de aluminio anodizado es específico para fijación a pared.

APLICACIONES: Paredes.

COLOR: Aluminio anodizado.

# Natsumi

SHAPES / FORMAS  
SYSTEM / SISTEMA

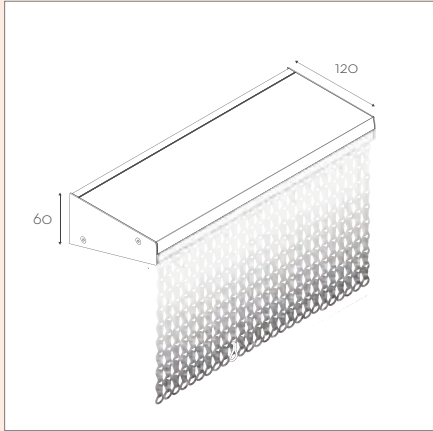

**Illuminate to the chain artwork with this integrated lighting system rail.**

**TECHNICAL INFORMATION:**

LED White 4000 K, 20 W/m, 810 Lm/m, 24 V. Possibility of incorporating dimmer.

LED RGB, 19 W/m, 24 V. Possibility of incorporating light intensity and color control device.

Connection: 230 V.

IP20 protection for interior uses.

Illuminates 1 m of chain intensively. Creates a shadow effect until the bottom of the chain.

**APPLICATIONS:**

Wall fixed straight structures with lighting.

**COLOUR:** Anodized aluminium.

**Ilumina el diseño con este rail con sistema de iluminación integrado.**

**INFORMACIÓN TÉCNICA:**

LED Blanco 4000 K, 20 W/m, 810 Lm/m, 24 V. Posibilidad de incorporar control de intensidad.

LED RGB, 19 W/m, 24 V. Posibilidad de incorporar control de intensidad de luz y color.

Conexión: 230 V.

Protección IP20 para usos interiores.

Ilumina 1 m de cadena de manera intensa. Crea un efecto de sombras hasta el final de la cadena.

**APLICACIONES:**

Estructuras rectas de pared con iluminación.

**COLOR:** Aluminio anodizado.

# Rainy ceiling / Techo efecto lluvia

SHAPES / FORMAS  
SYSTEM / SISTEMA

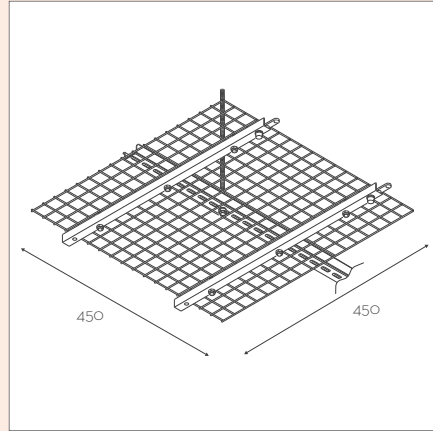

**This structure makes possible to recreate a rainy effect, combining different densities, chain lengths and gradients of colours. It is even possible to customize the shape for different areas.**

**APPLICATIONS:** Ceiling.

**MATERIAL:** Aluminium, stainless steel, galvanized steel.

**COLOUR:** STRUCTURE: Metallic. Can be lacquered under request.

CHAINS: Solid colours or gradations.

**Esta estructura permite recrear un efecto lluvia, combinando diferentes densidades, longitudes de cadenas y degradados de colores. Incluso es posible personalizar la forma para diferentes áreas.**

**APLICACIONES:** Techo.

**MATERIAL:** Aluminio, acero inox, acero galvanizado.

**COLOR:** ESTRUCTURA: Metálica. Puede lacarse bajo petición.

CADENAS: Colores sólidos o degradados.

**CHAIN DENSITIES / DENSIDAD DE LA CADENA**

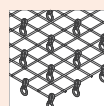

**100%**  
(1600 strands - tiras / sqm-m2)

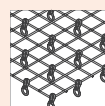

**50%**  
(800 strands - tiras / sqm-m2)

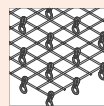

**25%**  
(400 strands - tiras / sqm-m2)

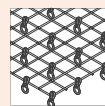

**12%**  
(203 strands - tiras / sqm-m2)

**VOLUME / VOLUMEN**

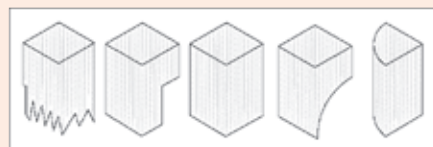

Others / Otros

# Ceiling waves / Ondas de techo

SHAPES / FORMAS  
SYSTEM / SISTEMA

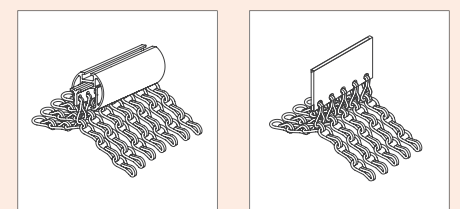
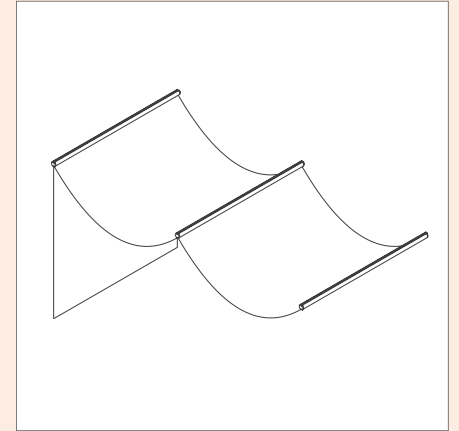

**Creating waves on ceilings of any width or any height is possible with this system. It is possible to use solid colours, gradients or patterns.**

**APPLICATIONS:** Ceiling or walls.

**COLOUR:** STRUCTURE: Anodized aluminium. CHAINS: Solid colours or gradations.

**Crear ondas en techos de cualquier ancho o altura es posible con este sistema. Es posible utilizar colores sólidos, degradados o estampados.**

**APLICACIONES:** Techo o pared.

**COLOR:** ESTRUCTURA: Aluminio anodizado. CADENAS: Colores sólidos o degradados.

## Minioval mobile curtain / Minioval cortina móvil

SHAPES / FORMAS



SYSTEM / SISTEMA

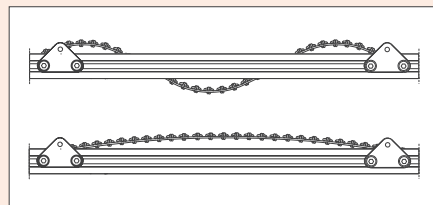
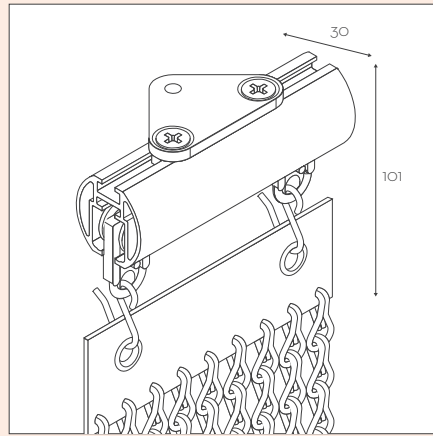

## Sliding panel system / Panel japonés

SHAPES / FORMAS



SYSTEM / SISTEMA

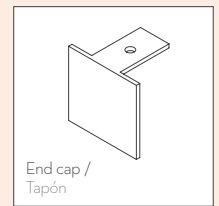
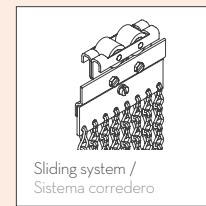
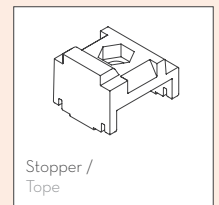
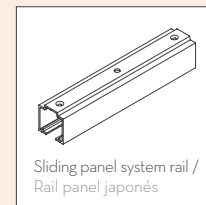
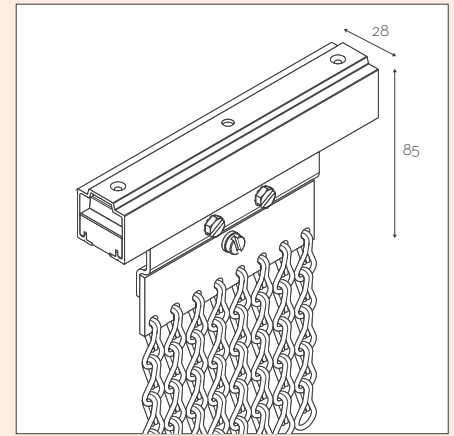

This panel system allows independent manual movement of parallel panels.

APPLICATIONS: Ceiling.

COLOUR: Anodized aluminium.

Si se necesitan crear formas este rail es la solución adecuada.

APLICACIONES: Techo.

COLOR: Aluminio anodizado.



Fixed / Fijo



Mobile / Móvil



Rainy effect / Efecto lluvia



Ceiling waves / Ondas de techo



Straight / Rectas



Curved / Curvadas



Undulated / Onduladas



When dynamism and mobility are required, this mobile curtain is the solution because it can be opened and closed. The chain is fastened to a flexible textile strip which slides along the rail. With this system it is possible to create circular or curved areas.

APPLICATIONS: Ceiling or wall installation.

MOVEABLE STRAIGHT & CURVED CURTAINS:  
min. radius of 40 cm.

GATHERING: 25-30% of the total length when gathered up.

Cuando se necesita dinamismo y movilidad, esta cortina móvil es la solución porque puede abrirse y cerrarse. La cadena está fijada a una cinta textil que se desliza a lo largo del rail. Con este sistema se pueden crear áreas circulares o curvadas.

APLICACIONES: Techo o pared.

CORTINAS FIJAS RECTAS Y CURVADAS:  
radio mín. 40 cm.

FRUNCIDO: 25-30% de la anchura total cuando está recogida.

SIZES in mm

MEDIDAS en mm

COLOUR: Fixation systems can be lacquered in other colours under request.

COLOR: Los sistemas de fijación pueden lacarse en otros colores bajo petición.





Mandarin. Ducks and Noodles by Sundukovy Sisters. Photo by Denis Vasiliev



# Chain measurements, installation & maintenance / Medidas de la cadena, instalación y mantenimiento

Projects can be adapted to any size, height and width. Aluminium is a very light element and it is easy to handle. Material is delivered with the measurements as indicated by the customer.

The sizes always include the rail and the support system. Installation is simple and does not require specialised personnel. Before installation, check that the element where the structure will be installed will be able to take its weight.

Due to the size of the links and the spaces between strands, the measurements may not be exact, although they are as close as technically possible to the height and width requested, without exceeding these measurements. For better chain effect, we recommend leaving a 2 cm space at the bottom.

For chain maintenance, clean with water and mild soap (not basic). Steam can also be used. The chain's guarantee for indoor use is 5 years except in case of damages caused by accident, inappropriate use or any other external cause.

Los proyectos se pueden realizar en cualquier medida, tanto en anchura como en altura. El aluminio es un elemento muy ligero, de fácil manipulación. La instalación es sencilla y no precisa de personal especializado. Antes de la instalación, es necesario comprobar que la estructura donde se instalará la cadena resiste el peso de la misma. El material se suministra según la medida indicada por el cliente. Las medidas siempre incluyen el rail y el sistema de sujeción.

Debido al tamaño de los eslabones y a la separación entre tiras, las medidas pueden no ser exactas, aunque se aproximarán tanto como sea técnicamente posible a la altura y anchura solicitadas, sin sobrepasar esas medidas. Para una mejor presencia de la cadena, recomendamos dejar libres 2 cm en la parte inferior.

Para su mantenimiento, la limpieza se realiza con agua y jabón neutro (no básico). También puede utilizarse vapor.

La garantía de la cadena para uso en interior es de 5 años salvo en caso de daños causados por accidente, uso indebido o cualquier otra causa externa.

# Other options / Otras opciones

## Inferior fastening / Sujeción inferior

To prevent the strands from moving freely, there is the option of fastening the lower part to a rail that is fixed to the floor. Used mainly in outdoor installations.

Para evitar que las tiras se puedan mover, existe la posibilidad de fijarlas en la parte inferior mediante un rail sujeto al suelo. Principalmente usado en instalaciones de exterior.

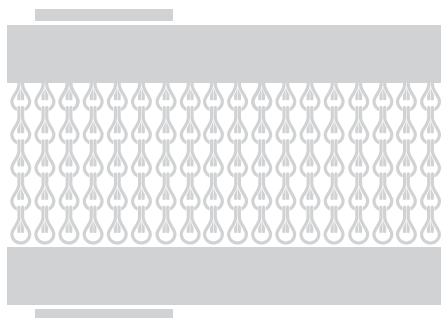

## Chain linking / Enlazado de cadena

The chains can be joined together using rings, at any height and as many times as required. This option gives the curtain rigidity simulating a textile fabric and prevents crossing through the chain panel.

Es posible enlazar las cadenas entre si mediante anillas, a cualquier altura y tantas veces como sea necesario. Esta opción aporta rigidez simulando un tejido y evita el paso a través.

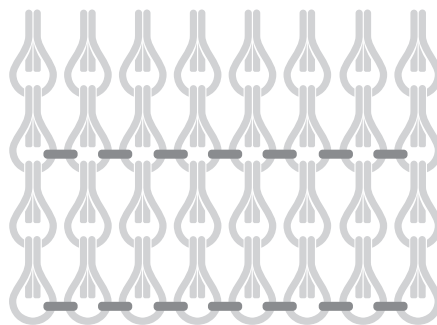

## Chain shaping / Vaciados de cadena

Trimming off the chains allow creating shapes. This shaping can follow straight or curved lines to create surprising effects. The chain can be demarked with a frame or remain free.

Recortar las cadenas permite crear formas. El vaciado puede seguir líneas rectas o curvas para crear efectos sorprendentes. La cadena puede enmarcarse o permanecer libre.

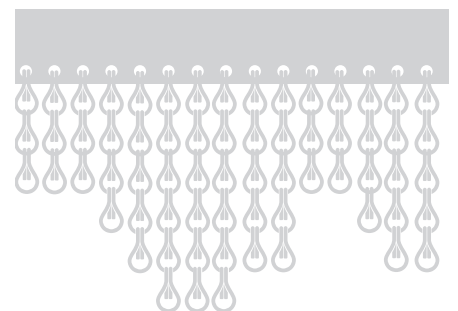

# Technical specifications / Especificaciones técnicas

The aluminium in the Kriskadecor links goes through our special anodizing treatment, specially designed for our chains, which gives them improved robustness and offers high colour resistance against climatic factors, wear and rusting.

El aluminio de las cadenas Kriskadecor se somete a un tratamiento de anodizado especial que les proporciona una mayor dureza y aporta una alta resistencia de los colores a los factores climáticos, así como al rozamiento y la oxidación.

Anodized aluminium thickness's link: Kriska 2 mm and Snina 1,5 mm.

Grosor de los eslabones de aluminio anodizado: Kriska 2 mm y Snina 1,5 mm.

Maximum static load without break: Kriska 17 kg (approx.) / Snina 11 kg (approx.)

La carga estática máxima sin rotura: Kriska 17 kg y Snina 11 kg (aprox.).

Aluminium chain with anodized coating thickness between 8,5 and 12 microns, depending of colour and finish.

Cadena de aluminio anodizado con capa de recubrimiento entre 8,5 y 12 micras, dependiendo del color y acabado.



Material composition of 99,7% in aluminium. Minimum of 20% of recycled aluminium.



Composición del material de 99,7% en aluminio. Mínimo del 20% procedente de aluminio reciclado.

Soft finish. No roughness perceptible in coating.

Acabado suave. Rugosidad imperceptible.

40% to 60% opacity with a 90° incidence of light, depending on the spacing between chains and on the finishing of the chains (brilliant or satin).

Opacidad entre 40% y 60% con un ángulo de inclinación de 90°, dependiendo del espaciado y el acabado (brillo o satinado).



No electrical conductivity.



No conductor de la electricidad.



No sound absorption.



No absorbe sonido.



Non-flammable. Fire ratings A1.



Clasificación A1 de resistencia al fuego (no inflamable).



Resistant to acids with a pH value up to 8 (not resistant to alkaline products).  
Avoid cleaning with products with pH higher than 8.



Resistente a los productos ácidos de pH inferior a 8 (no a productos alcalinos).  
Para la limpieza no utilizar productos con pH superior a 8.



Rustproof.



Resistente a la oxidación.



Working temperature allowed: -30°C up to 50°C.



Temperatura recomendada de trabajo: -30°C hasta 50°C.



Resistant to seawater.



Resistente al agua de mar.

		Kriska		Snina	
WEIGHT / PESOS (aprox)	kg / sqm kg / m2	Standard 3,03	Half-drop 3,88	Standard 2,25	Half-drop 2,96



**Public spaces /  
Espacios públicos**

**Residential /  
Residencial**

**Hotels and restaurants /  
Hoteles y restaurantes**

**Leisure / Ocio**

**Shops and shopping centers /  
Tiendas y centros comerciales**

**Stands and events /  
Stands y eventos**

**Art / Arte**

# Projects / Proyectos

**Offices / Oficinas**



Vinci Gala Hotel by TBI Architecture & Engineering. Photo by José Hevia







# PULL & BEAR

## REBAIXES

SAMARRETA  
DES DE  
**3'99**  
€

FINA AL  
**-60%**

VESTIT  
DES DE  
**9'99**  
€







Wahaca Canary Wharf Restaurant by Softroom Architects. Photo by Alex Maguire





Marriott Renaissance Wien Hotel by Christian Olufemi Architekten and Brumann Innenraumkonzepte GmbH. Photo by David Bohmann





Allude Flagship Store by Regina Dahmen-Ingenhoven. Photo by Kilian Bishop





Krskadecor's stand at Downtown Design Dubai by Sancal Design Team





Watermark Westquay by MTRDC Michelle Taylor. Photo by Ben Luxmoore









Elorrin Offices by Gaz arquitectos. Photo by Iñaki Eskubi



**Hotels** / Marriott Reinassance · Wien · Austria / W · Fort Lauderdale · USA / Le Méridien Ra · El Vendrell · Spain / Mama Shelter · Marseille · France / Isrotel · Tel Aviv · Israel / Riu Plaza Panamá · Panama City · Panama / Royal Ascot Hotel Apartment · Dubai · UAE / Sheraton München Westpark Hotel · Munich · Germany / Sofitel Queenstown · Queenstown · New Zealand / Stora Hotellet · Umeå · Sweden / The Westin Sydney · Sydney · Australia / Yotel · New York · USA / Vincci Gala Hotel · Barcelona · Spain / **Restaurants** / Häagen-Dazs · Berlin · Germany / Cinc Sentits · Barcelona · Spain / Arsenal Emirates Stadium · London · UK / Dos Palillos By Camper · Barcelona · Spain / Hard Rock Café - Mall of America · Bloomington · USA / Coure · Barcelona · Spain / Etihad Stadium Manchester City

F.C. - The Mancunians • Manchester •  
UK / **Public Spaces** / **Museums** / Abba  
The Museum • Stockholm • Sweden /  
**Airport** / Dallas Fort Worth Airport •  
Dallas • USA / **Events** / Academy Awards  
- Oscar's Ceremony • Los Angeles • USA  
/ BMW Series 3 Sport • Several Cities •  
Italy / **Stands** / B&B • Köln • Germany /  
Kawasaki • Barcelona • Spain / Pfizer •  
Madrid • Spain / **Shops & Shopping  
Centers** / Harrods • London • UK /  
Hoss Intropia • Several Cities •  
Worldwide / Pull & Bear • Several Cities •  
Worldwide / **Offices** / Accenture •  
Barcelona • Spain / Google • Dubai •  
UAE / **Casinos** / Cosmopolitan Casino •  
Las Vegas • USA / MGM Grand Macau •  
Macau • China / **Discotheques & Clubs** /  
Pacha Moscow • Moscow • Russia / Teatro  
Rauxa • Tulum • Mexico / Cavalli Club •  
Marbella • Spain





Sea Brush Strokes by Claire Davies

# Ideas by Kriskadecor / Ideas de Kriskadecor

---

## Collection

Patterns that fit in every ambient.

Estampados que encajan en cualquier ambiente.

---



---

## Screen dividers / Biombos

Dividing the space with artistic and highly customised chain art, all inside a frame.

Arte en cadena para dividir el espacio de manera artística y altamente personalizable. Todo dentro de un marco.

---



---

## Lamps / Lámparas

Standard and customizable lamps.

Lámparas estándar y personalizables.

---





## Local development / Desarrollo local

Krskadecor maintains its headquarters in Montblanc and, at the same time, it has a network of international distributors worldwide and new office in the United States.

Krskadecor also contributes regularly in the sponsorship of local events such as the renowned Medieval Week, along with other local activities.

Krskadecor mantiene su sede en Montblanc y, al mismo tiempo, tiene una red de distribuidores internacionales en todo el mundo y otra sede en Estados Unidos.

Krskadecor también contribuye regularmente en el patrocinio de eventos locales así como la renombrada Semana Medieval, junto con otras actividades locales.

## Education / Educación

We think that young talent is one of the most important human investments that our company can make. That is why we are involved with educational entities, offering training and grants for internships for graduates and undergraduate students.

Creemos que el talento joven es una de las inversiones humanas más importantes que nuestra empresa puede hacer. Es por eso que estamos involucrados con entidades educativas, ofreciendo experiencia y becas de prácticas para graduados y estudiantes universitarios.

## Eco friendly / Eco friendly

In order to minimise our ecological footprint to the maximum, we invest all of our available efforts and resources in it.

Our aim is achieving products that are attractive, useful, long-lasting and, above all, that respect the environment. The chain is 100% recyclable.

Our company upholds the 3R law: Reduce, Recycle and Re-use. Our products are made with aluminium that contains at least 20% of recycled material, the production of which consumes fewer resources, so that we reduce our carbon footprint.

As an inner process into our different production processes we re-use the water in order to minimize the use of this resource.

Tenemos el objetivo de minimizar al máximo nuestro impacto en el medio ambiente, invirtiendo recursos y esfuerzos en ello.

Nuestra intención es lograr productos atractivos, útiles, duraderos y respetuosos con el medio ambiente. La cadena es 100% reciclable.

Nuestra empresa cumple la ley 3R: reducir, reciclar y reutilizar. Nuestros productos están hechos de aluminio y contienen como mínimo el 20% de material reciclado, por lo que su producción consume menos recursos para reducir nuestra huella de carbono.

Dentro de nuestros diferentes procesos de producción se reutiliza el agua para minimizar el uso de este recurso.

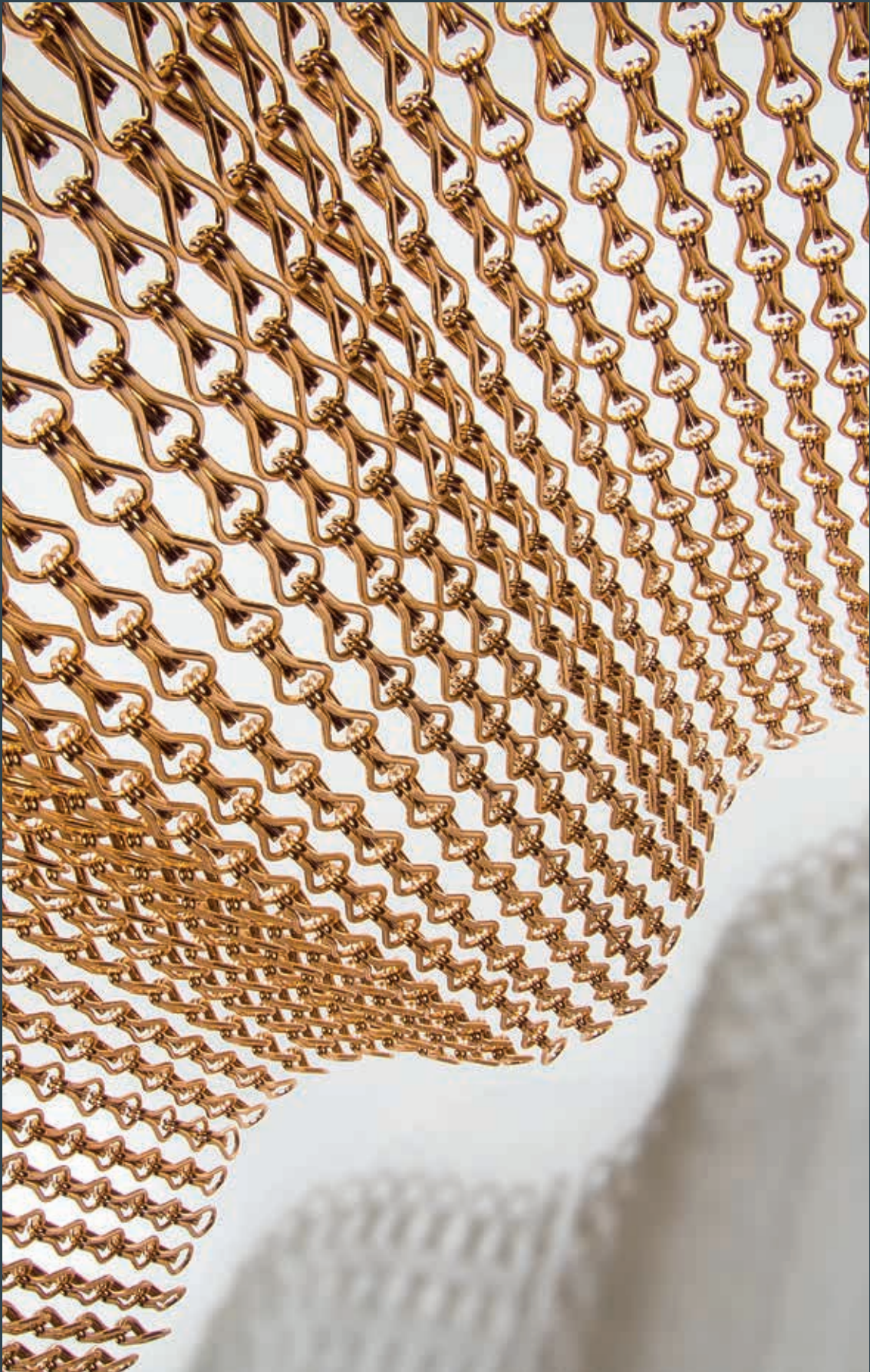

Cover and upper photo by Pere Queralt



linking  
ideas

**Kriskadecor**  
[www.kriskadecor.com](http://www.kriskadecor.com)  
[info@kriskadecor.com](mailto:info@kriskadecor.com)

**Kriskadecor USA**  
[www.kriskadecor.us](http://www.kriskadecor.us)  
[info@kriskadecor.us](mailto:info@kriskadecor.us)