

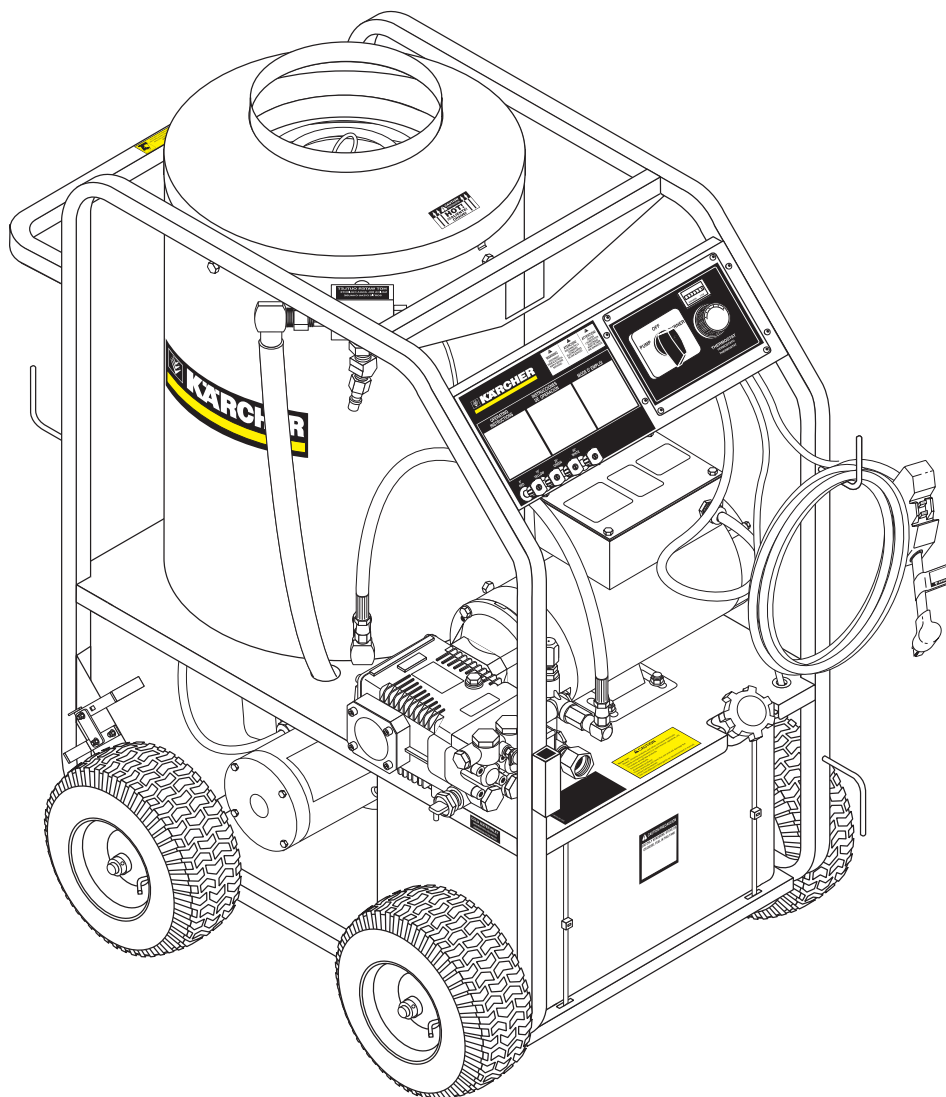

KÄRCHER

OPERATOR'S MANUAL



MODEL HDS 2.0/10 Ed Cage - 1.575-511.0

MODEL HDS 1.9/15 Ed Cage - 1.575-512.0

MODEL HDS 3.5/20 Ea Cage - 1.575-513.0

To locate your local Kärcher Commercial Pressure Washer Dealer nearest you,
please call 1-888-805-9852 or visit www.karchercommercial.us

9.800-191.0

CONTENTS

Introduction and Safety Information	4-5
Component Identification	6
Operating Instructions	7-8
Preventative Maintenance and Service	9-11
Exploded Views	12-13
Exploded Views Parts List	14-15
Control Panel Exploded View and Parts List	16-17
Hose & Spray Gun Assembly and Parts List	18
Downstream Injector Assembly and Parts List	19
Unloader Exploded View and Parts List	20
Pump Exploded View and Parts List	21-22
Troubleshooting	23
Maintenance Schedule	24
Warranty	

Model Number _____

Serial Number _____

Date of Purchase _____

The model and serial numbers will be found on a decal attached to the pressure washer. You should record both serial number and date of purchase and keep in a safe place for future reference.

INTRODUCTION & IMPORTANT SAFETY INFORMATION

This manual covers the operation and maintenance of the 1.575-511.0, 1.575-512.0, 1.575-513.0 pressure washers. All information in this manual is based on the latest product information available at the time of printing.

We reserve the right to make changes at any time without incurring any obligation.

Owner/User Responsibility:

The owner and/or user must have an understanding of the manufacturer's operating instructions and warnings before using this pressure washer. Warning information should be emphasized and understood. If the operator is not fluent in English, the manufacturer's instructions and warnings shall be read to and discussed with the operator in the operator's native language by the purchaser/owner, making sure that the operator comprehends its contents.

Owner and/or user must study and maintain for future reference the manufacturers' instructions.

This manual should be considered a permanent part of the machine and should remain with it if machine is resold.

When ordering parts, please specify model and serial number.

IMPORTANT SAFETY INSTRUCTIONS

WARNING: When using this machine basic precautions should always be followed, including the following:



CAUTION: To reduce the risk of injury, read operating instructions carefully before using.

1. Read the owner's manual thoroughly. Failure to follow instructions could cause malfunction of the machine and result in death, serious bodily injury and/or property damage.
2. All installations must comply with local codes. Contact your electrician, plumber, utility company or the selling distributor for specific details. To comply with National Electrical Code (NGPA 70) and provide additional protection from risk of electric shock, this hot water converter is equipped with a UL approved ground fault circuit interrupter (GFCI) power cord.



WARNING: Flammable liquids can create fumes which can ignite causing property damage or severe injury.

WARNING: Do not use gasoline, crankcase draining or oil containing gasoline, solvents or alcohol. Doing so will result in fire and/or explosion.

WARNING: Do not spray flammable liquids. Operate only where an open torch is permitted.

3. This fuel burning machine shall be installed only in locations where combustible dusts and flammable gasses or vapors are not present.
4. In these oil burning models, use only kerosene, No. 1 home heating fuel, or diesel fuel.



Warning: Keep water spray, wand, and high pressure hose away from electrical wiring or fatal electric shock may result. Read warning tag on electrical cord.

5. To protect the operator from electrical shock, the machine must be electrically grounded. It is the responsibility of the owner to connect this machine to a UL grounded receptacle of proper voltage and amperage ratings. Do not spray water on or near electrical components. Do not touch machine with wet hands or while standing in water. Always disconnect power before servicing.

CAUTION: Spray gun kicks back - hold with both hands.

6. Grip cleaning wand of attached pressure washer securely with both hands before starting cleaner. Failure to do this could result in injury from a whipping wand.



WARNING: High pressure stream of fluid that this equipment can produce can pierce the skin and its underlying tissues, leading to serious injury and possible amputation.

7. High pressure developed by the attached pressure washer can cause bodily injury or damage. Use caution when operating. Do not point the spray gun at anyone or at any part of the body. This machine is to be used only by qualified operators.

8. Never make adjustments on machine while it is in operation.

IMPORTANT SAFETY INFORMATION



WARNING: High pressure spray can cause paint chips or other particles to become airborne and fly at high speeds.

9. Eye safety devices must be worn when using this equipment.



WARNING: Risk of asphyxiation - Use this product only in a well ventilated area.

10. When the machine is working, do not cover or place in a closed space where ventilation is insufficient.



WARNING: Risk of fire. Do not add fuel when the machine is operating or still hot.

11. Machines with a spray gun should not be operated with the spray gun in the off position for extended periods of time as this may cause damage to the pump. Check to make sure burner shuts off when spray gun trigger is closed.

12. Protect from freezing.
13. To prevent a serious injury, make certain quick coupler on discharge hose has locked before using pressure washer.
14. Do not allow acids, caustic or abrasive fluids to pass through the pump.
15. Inlet water must be cold and clean fresh water.
16. Do not allow CHILDREN to operate the pressure washer at any time. **THIS MACHINE MUST BE ATTENDED DURING OPERATION.**
17. The best insurance against an accident is precaution, and knowledge of the machine.
18. Do not operate this product when fatigued or under the influence of alcohol or drugs. Keep operating area clear of all persons.
19. We will not be liable for any changes made to our standard machines, or any components not purchased from us.
20. Do not overreach or stand on unstable support. Keep good footing and balance at all times.
21. Follow the maintenance instructions specified in the manual.

22. When making repairs disconnect from electrical source.
23. Turn burner off and open spray gun to allow water to flow and cool coil to 100°F before turning machine off.
24. Before disconnecting high pressure hose from hot water outlet, turn off burner to allow water to cool to 100°F, then turn off pump motor and water supply and operate spray gun to relieve back pressure in hose. This will prevent coil damage from thermal expansion.

CAUTION: This machine produces hot water and must have insulated components attached to protect the operator.

INSTALLATION

Place machine in a convenient location providing ample support, draining and room for maintenance.

This machine is intended for indoor use. Machine must be stored indoors when not in use.

Location:

The location should protect the machine from damaging environmental conditions, such as wind, rain, and freezing.

1. This machine should be run on a level surface where it is not readily influenced by outside sources such as strong winds, freezing temperature, rain, etc. It should be located to allow accessibility for refilling of fuel, adjustments, and maintenance. Normal precautions should be taken by the operator of the machine to prevent moisture from reaching the electrical controls.
2. It is recommended that a partition be made between the wash area and the machine to prevent water spray from coming in contact with the machine. Excess moisture reaching any electric components or electrical controls will reduce machine life and may cause electrical shorts.
3. During installation of the machine, beware of poorly ventilated locations or areas where exhaust fans may cause an insufficient supply of oxygen. Sufficient combustion can only be obtained when there is a sufficient supply of oxygen available for the amount of fuel being burned. If it is necessary to install a machine in a poorly ventilated area, outside fresh air may have to be piped to the burner and a fan installed to bring air into the machine.

Avoid small locations or areas near exhaust fans.

COMPONENT IDENTIFICATION

CAUTION HOT WATER:
Must use insulated spray gun and wand.

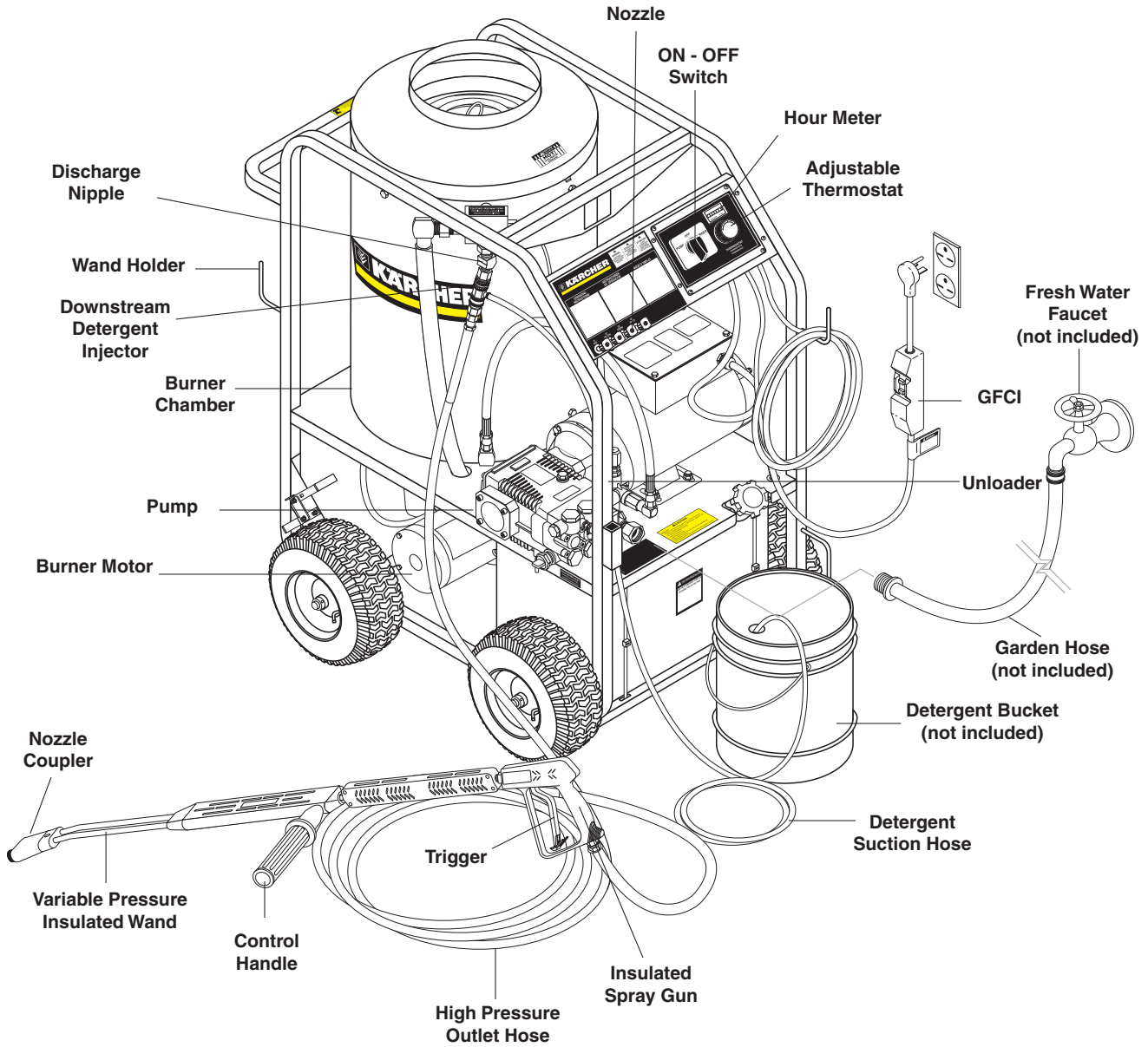

OPERATING INSTRUCTIONS

Electrical:

This machine, when installed, must be electrically grounded in accordance to local codes. Check for proper power supply using a volt meter.

Placement:

Do not locate near any combustible material. Keep all flammable material at least 20 feet away.

Allow enough space for servicing the machine.

Local code will require certain distances from floor and walls. (Two feet away from walls should be adequate.)

Water Source:

The water source for the pressure washer should be supplied by a minimum 5/8" I.D. garden hose with a city water pressure of not less than 30 PSI. If the water supply is inadequate, or if the garden hose is kinked, the attached pressure washer will run very rough and the burner will not fire.

Connection:

Connect the wand, nozzle, hose and spray gun (where applicable). On pipe thread connections, use teflon tape to avoid water leaks. (See Component Identification).

Venting:

Adding exhaust vent pipe to your oil fired burner is not recommended because restricted air flow causes carbon buildup, which affects the operation, and increases maintenance on the coil. If a stack must be used, refrain from using 90° bends. If the pipe can not go straight up then use only 45° bends and go to the next size pipe. The overall pipe length must not exceed 6 feet in length.

5. Insert quick coupler onto discharge nipple and secure by pushing quick coupler collar forward.
6. Securely attach the desired high pressure nozzle into wand coupler as described in steps 4 and 5.
7. Connect the power cord into the proper electrical outlet, then push in the GFCI reset button (Refer to serial plate for information.)
8. Grip spray gun handle securely and pull trigger. Then turn variable pressure control handle counterclockwise.
9. Turn switch to pump position. When a steady stream of water flows from the spray gun and wand, the machine is ready for cold water cleaning by turning the variable pressure control handle clockwise to raise the pressure.

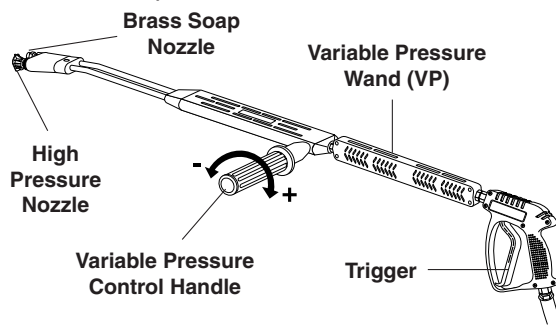

Selection of high or low pressure is accompanied by turning the handle. **Note:** High pressure nozzle must be inserted at end of wand to obtain high pressure. To apply soap read operator's manual.

10. For hot water washing, turn the switch to the burner position. (The burner will light automatically when the trigger on the spray gun is pulled.)

STARTING AND OPERATING INSTRUCTIONS

To Start:

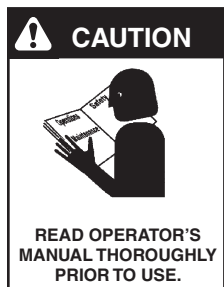

1. **STOP!** Read operator's manual before operating. Failure to read operation and warning instructions may result in personal injury or property damage.
2. Connect water supply hose and turn on water.
3. Check fuel tank and pump oil levels.
4. Connect high pressure hose to discharge nipple by sliding quick coupler collar back. (If detergent is to be applied, insert a detergent injector as shown in Component Identification).

To Stop:

1. If using the detergent injector, place the suction line in a bucket of water allowing detergent to be flushed from system.
2. Turn burner switch off and continue spraying water, allowing the water to cool.
3. After water has cooled to less than 100°F, turn the attached pressure washer off.
4. Turn garden hose water off. Open the spray gun to relieve remaining pressure.
5. Protect from freezing.

OPERATING INSTRUCTIONS

HOW TO USE THE DETERGENT INJECTOR

WARNING



SOME DETERGENTS MAY BE HARMFUL IF INHALED OR INGESTED.

WARNING: *Some detergents may be harmful if inhaled or ingested causing severe nausea, fainting or poisoning. The harmful elements may cause property damage or severe injury.*

The machine can siphon and mix detergents with the use of Shark's detergent injector kit.

1. Pull injector quick coupler collar back and secure on discharge nipple. Injector valve body arrow should point in direction of flow.
2. Connect high pressure hose to injector nipple securing quick coupler.
3. Start machine as outlined in Operating Instructions.
4. Place detergent pick-up tube into container of detergent solution.
5. Turn pressure control handle counterclockwise on the variable pressure wand. This lowers the pressure by directing the water flow through the soap nozzle and allows the detergent injector to siphon soap.
6. Open trigger spray gun. Water detergent ratio is approximately 15 to 1.
7. When you finish washing, rinse by simply turning the variable pressure wand control handle clockwise to increase pressure.
8. For clean up, place detergent pick-up tube into container of clear water and follow steps 5 and 8 to prevent detergent deposits from damaging the injector.

NOTE: The detergent injector will not siphon with water flowing through the high pressure nozzle at the end of the wand.

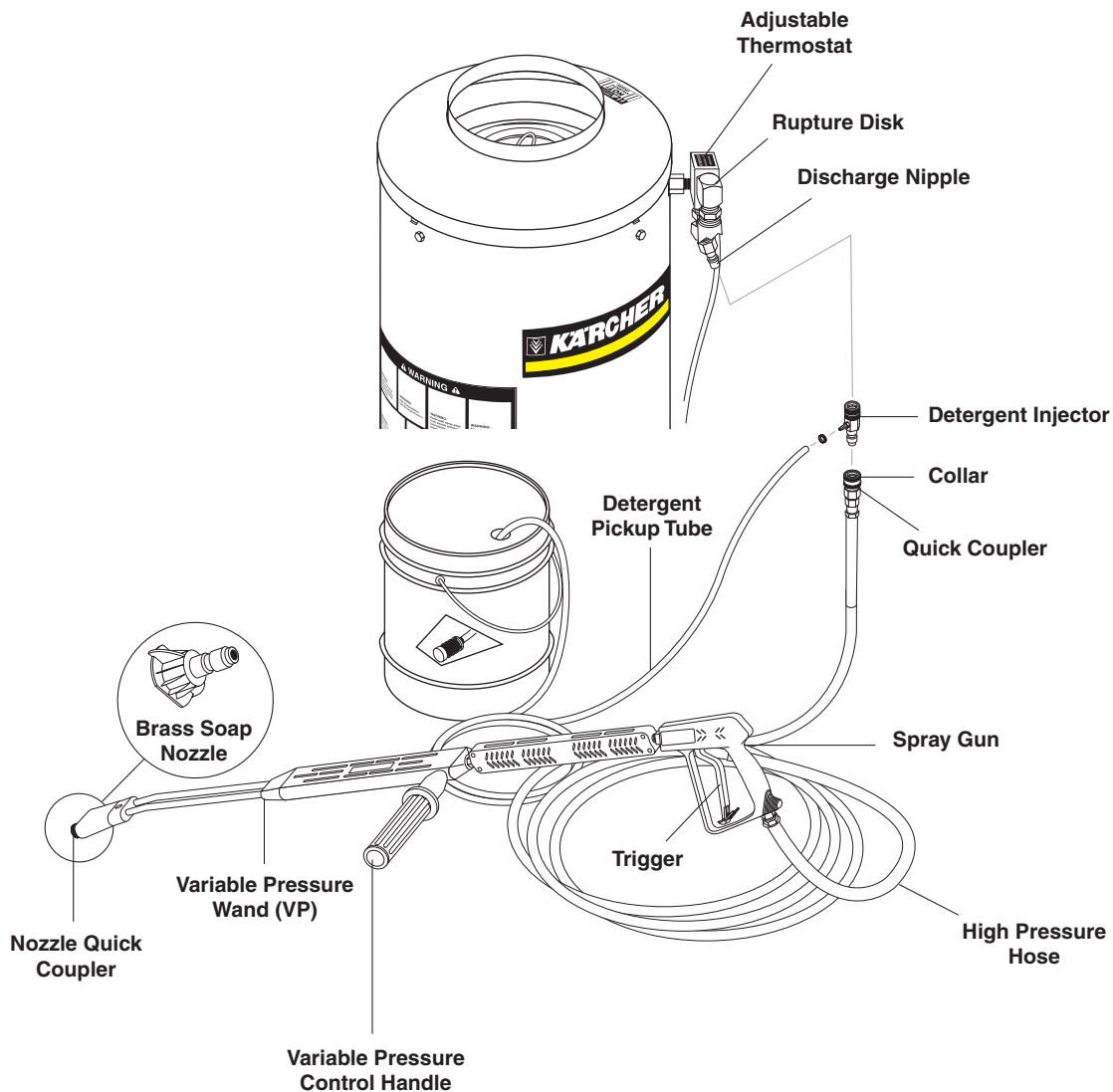

PREVENTATIVE MAINTENANCE

1. Use clean fuel - kerosene, No. 1 home heating fuel or diesel fuel. Clean or replace fuel filter every 100 hours of operation. Avoid water contaminated fuel as it will seize up the fuel pump. De-soot coils monthly. Use an additive if diesel is being used.
2. Check to see that the attached pressure washer water pump is properly lubricated.
3. Follow Winterizing Procedures to prevent freeze damage to pump coils.
4. Always neutralize and flush detergent from system after use.
5. If water is known to be high in mineral content, use a water softener in your water system or de-scale as needed.
6. Do not allow acidic, caustic or abrasive fluids to be pumped through system.
7. Always use high grade quality cleaning products.
8. Never run pump dry for extended periods of time.
9. If machine is operated with smoking or eye burning exhaust, coils will soot up, not letting water reach maximum operating temperature. (See section on Air Adjustments.)
10. Never allow water to be sprayed on or near engine or burner assembly or any electrical component.
11. Periodically delime coils per instructions.

It is advisable, periodically, to visually inspect the burner. Check air inlet to make sure it is not clogged or blocked. Wipe off any oil spills and keep this equipment clean and dry.

The areas around the pressure washer should be kept clean and free of combustible materials, gasoline and other flammable vapors and liquids.

The flow of combustion and ventilating air to the burner must not be blocked or obstructed in any manner.

MAINTENANCE AND SERVICE

Unloader Valves:

Unloader valves are preset and tested at the factory before shipping. Occasional adjustment of the unloader may be necessary to maintain correct pressure. Call your local dealer for assistance.

Winterizing Procedure:

Damage due to freezing is not covered by warranty. Adhere to the following cold weather procedures whenever washer must be stored or operated outdoors under freezing conditions. During winter months, when temperatures drop below 32°F, protecting your machine against freezing is necessary. Store machine in a heated room. If this is not possible then mix a 50/50

solution of anti-freeze/water into a 5 gallon bucket. Place a short section of garden hose into bucket and connect it to machine. Elevate bucket and turn pump on to siphon anti-freeze through machine. If compressed air is available, an air fitting can be screwed into the inlet connector and, by injecting compressed air, all water will be blown out of system.

High Limit Hot Water Thermostat:

For safety, each machine is equipped with a high limit control switch. In the event that the temperature of the water should exceed its operating temperature, the high limit control will turn the burner off until the water cools.

Pumps:

Use only SAE 30W non-detergent oil. Change oil after the first 50 hours of use. Thereafter, change the oil every three months or at 500 hour intervals. Oil level should be checked by using the dipstick found on top of the pump or the red dot visible through the oil gauge window. Oil should be maintained at that level.

Cleaning of Coils:

In alkaline water areas, lime deposits can accumulate rapidly inside the coil pipes. This growth is increased by the extreme heat build up in the coil. The best prevention for liming conditions is to use high quality cleaning detergents. In areas where alkaline water is an extreme problem, periodic use of Deliming Powder (part #9.804-059.0) will remove lime and other deposits before coil becomes plugged. (See Deliming Instructions for use of Deliming Powder.)

Deliming Coils:

Periodic flushing of coils is recommended.

1. Fill a container or optional float tank with 4 gallons of water, then add 1 lb. of deliming powder. Mix thoroughly.
2. Remove wand assembly from spray gun and put spray gun into container. Secure the trigger on the spray gun into the open position.
3. Attach a short section (3-5 ft.) of garden hose to machine to siphon solution from an elevated container. Turn pump switch on, allowing solution to be pumped through coils back into the container. Solution should be allowed to circulate 2-4 hours.
4. After circulating solution flush entire system with fresh water. Reinstall wand assembly to spray gun.

Removal of Soot in Heating Coil:

In the heating process, fuel residue in the form of soot deposits may develop between the heating coil pipe and block air flow which will affect burner combustion. When soot has been detected on visual observation,

PREVENTATIVE MAINTENANCE AND SERVICE

the soot on the coil must be washed off after coil has been removed using the following steps:

1. Remove the tank head assembly by lifting the tank head off.
2. Remove the two pipe nipples and associated fittings.
3. Lift the coil out of the outer wrap.

CAUTION: the coil weighs about 80 lbs. Use proper lifting techniques.

4. Clean, repair and replace the coil by reversing the above steps.

Coil Reinstallation

Reinstall by reversing the above steps 4 through 1.

Rupture Disk

If pressure from pump or thermal expansion should exceed safe limits, the rupture disk will burst, allowing high pressure to be discharged through hose to ground. When the disk ruptures, it will need to be replaced.

Fuel:

Use clean fuel oil that is not contaminated with water and debris. Replace fuel filter and drain tank every 100 hours of operation. Use Kerosene No. 1 or No. 2 Heating Fuel (ASTM D306) or diesel only. **NEVER** use gasoline in your burner tank. Gasoline is more combustible than fuel oil and could result in a serious explosion. **NEVER** use crankcase or waste oil in your burner. Fuel unit malfunction could result from contamination.

Ignition Circuit:

Periodically inspect wires, spring contact and electrodes for condition, security and proper spacing. **For transformer test (CAUTION 10,000 VOLTS)** use defect free insulated screwdriver and keep fingers off blade! Lay blade across one contact: OK if arc will span 1/2" between end of blade and other contact (see following illustration).

Electrode Setting: Beckett

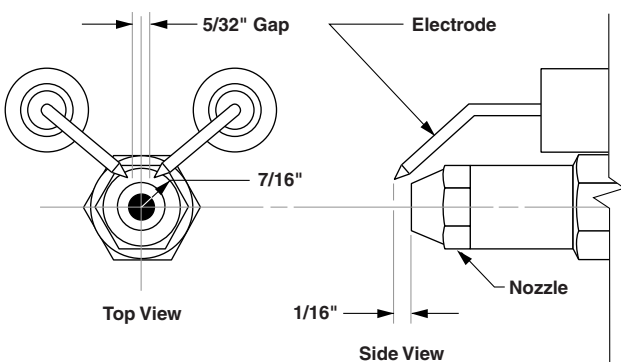

Burner Nozzle:

Keep the tip free of surface deposits by wiping it with a clean, solvent-saturated cloth, being careful not to plug or enlarge the nozzle. For maximum efficiency, replace the nozzle each season.

Fuel Control System:

The pressure washer utilizes a fuel solenoid valve located on the fuel pump to control flow of fuel to the combustion chamber. This solenoid is activated by a pressure switch located on the unloader valve. When an operator releases the trigger on the spray gun, the pressure drops, allowing the pressure switch to activate the fuel solenoid. The solenoid then closes, shutting off the supply of fuel to the combustion chamber. Controlling the flow of fuel in this way gives an instantaneous burn or no burn situation, thereby eliminating high and low water temperatures, and combustion smoke normally associated with machines incorporating a spray gun. Periodic inspection is recommended to insure that the fuel solenoid valve functions properly. This can be done by operating the machine and checking to see that when the trigger on the spray gun is in the off position, the burner is not firing.

Fuel Pressure Adjustment:

To adjust fuel pressure, turn the adjusting screw with a screwdriver (located on the fuel pump) clockwise to increase, counterclockwise to decrease. Do not exceed 200 PSI.

Air Adjustment

Machines are preset and performance tested at the factory — elevation 100' above sea level. A one time correction for your location will pay off in economy, performance and extended service life. If a smoky or eye-burning exhaust is being emitted from the stack, two things should be checked.

First, check the fuel to be certain that kerosene or No. 1 home heating fuel is being used.

Next, check the air adjustment on the burner. An oily, black, smoky fire indicates a lack of air and the air band should be moved to allow the air to flow through the burner. Sharp, eye-burning fumes indicate too much air flowing through the combustion chamber. The air band should be moved to allow less air to flow through the burner.

To adjust: Start the machine and turn burner ON. Loosen two locking screws found in the air shutter openings (refer to illustration) and close air shutter until black smoke appears from burner exhaust vent. Note air band position. Next slowly open the air shutter until white smoke just starts to appear. Turn air shutter half-way back to the black smoke position previously noted. Tighten locking screws.

FUEL AIR ADJUSTMENT

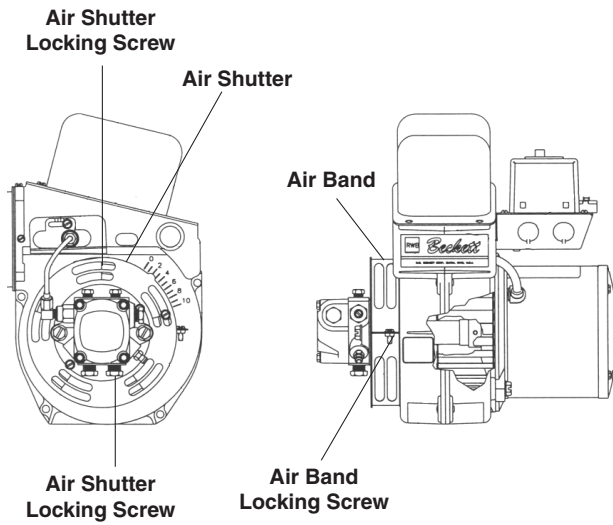

If the desired position cannot be obtained using only the air shutter, lock the air shutter in as close a position as can be obtained, then repeat the above procedure on the air band setting.

EXPLODED VIEW - LEFT

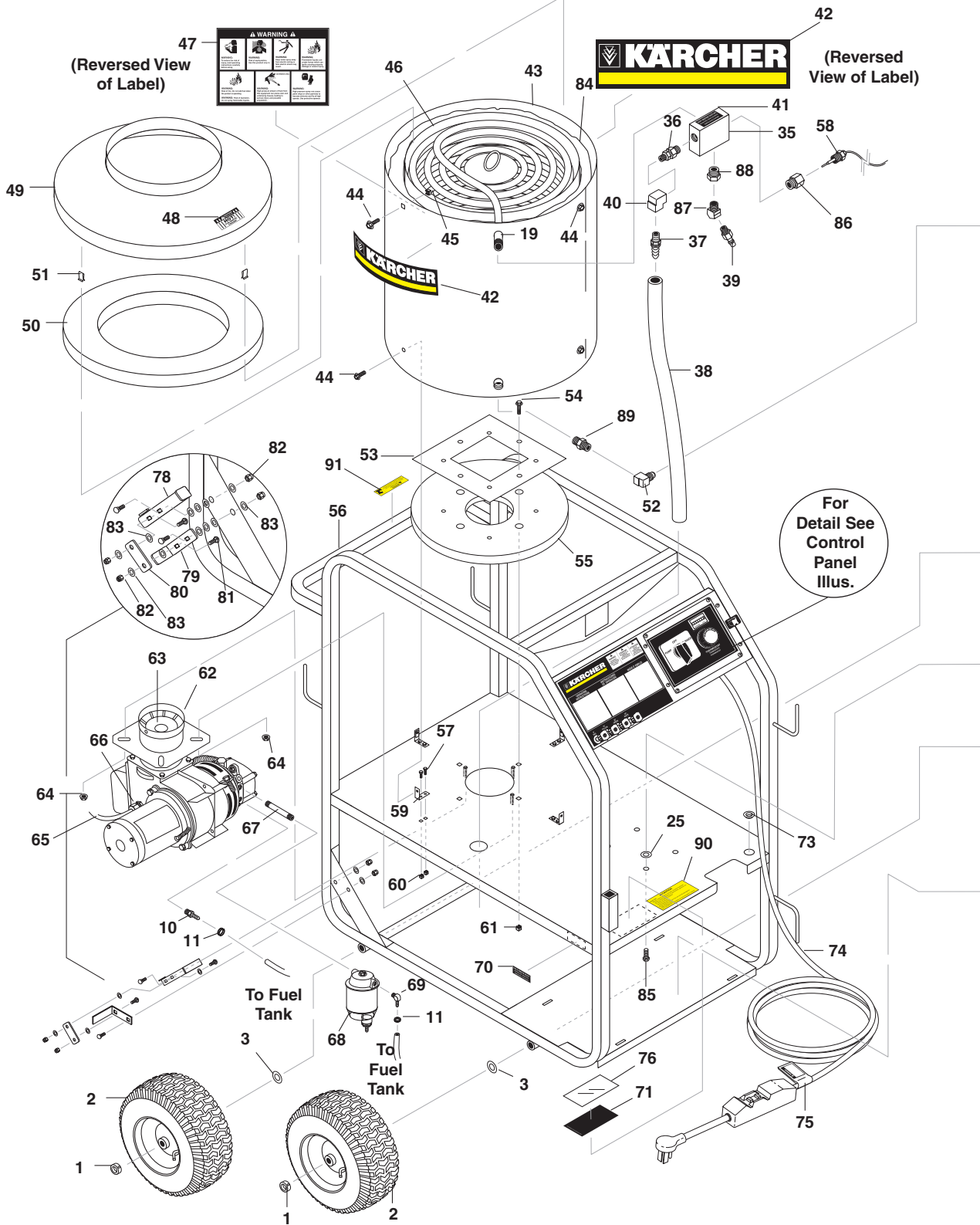

EXPLODED VIEW - RIGHT

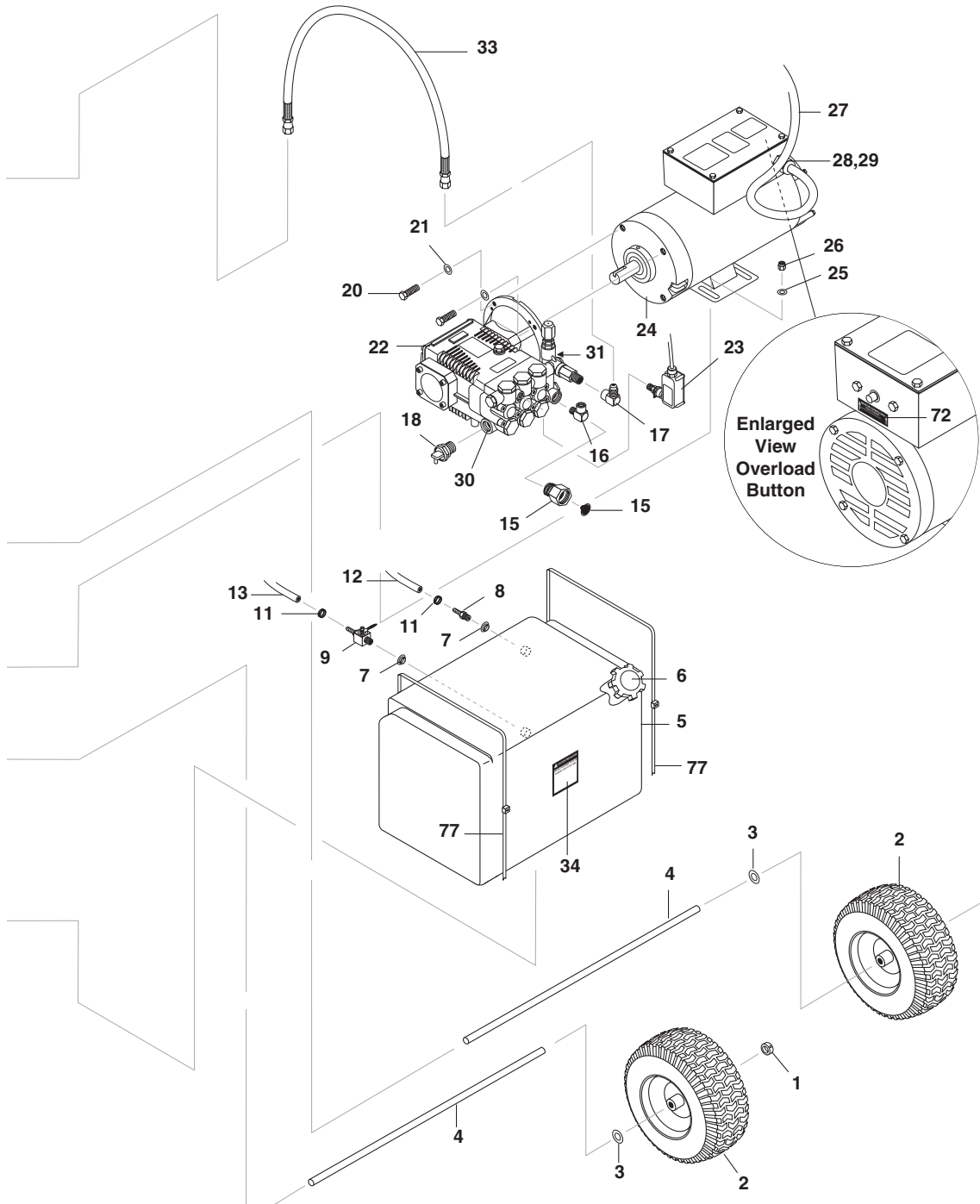

EXPLODED VIEWS PARTS LIST

ITEM	PART NO.	DESCRIPTION	QTY
1	9.802-782.0	Collar, 5/8" Bore Shaft	4
2	9.802-271.0	Wheel & Tire Assy, 6" Steel Rim w/Tube	4
3	9.802-810.0	Washer, 5/8", Flat, SAE	4
4	9.803-110.0	Axle, Rod 5/8" x 27.80" L	2
5	9.802-081.0	Tank, Fuel 6 Gallon Blank	1
6	9.802-089.0	Cap, Fuel Tank, Plastic H60-AV	1
7	9.802-053.0	Bushing, Rubber, Nitrile	2
8	9.802-141.0	Hose Barb, 1/4" Barb x 3/8" Barb, Double	1
9	9.802-177.0	Valve, 1/4" Shut-Off	1
10	9.802-138.0	Hose Barb, 1/4" Barb x 1/4" ML Pipe	1
11	9.802-210.0	Clamp, Hose, UNI .46 - .54	4
12	9.802-254.0	Hose, 1/4" Push-On, Fuel Line	11"
13	9.802-254.0	Hose, 1/4" Push-On, Fuel Line	7"
14	9.800-018.0	Label, Tipover Hazard	1
15	9.802-146.0	Swivel, 1/2" MP x 3/4" GHF w/Strainer	1
16	9.802-115.0	Elbow, 1/2" Street, Brass	1
17	9.802-039.0	Elbow, 1/2 JIC 3/8, 90°	1
18	9.802-182.0	Pump Protector, 1/2" PTP	1
19	9.802-013.0	Nipple, 1/2" x 2-1/2", Galvanized SCH 80	1
20	9.802-720.0	Bolt, 3/8" x 1", NC HH	4
21	9.802-807.0	Washer, 3/8" SAE, Flat	4
22	9.803-815.0	Pump, Kärcher KE2020S (511.0, 512.0)	1
	9.803-818.0	Pump, Kärcher KE3525F (513.0)	1
23	9.802-458.0	Switch, Pressure, N/O, 1/4" NPT SS	1
24	9.804-516.0	Motor, 1.5 HP 115V 1725 RPM (511.0)	1
	9.804-517.0	Motor, 2HP 1PH 115V 1725 RPM (512.0)	1
	9.802-341.0	Motor, 5HP 1PH 230V 3450 RPM (513.0)	1
25	9.802-804.0	Washer, 5/16" Flat, SAE	8
26	9.802-776.0	Nut, 5/16" ESNA, NC	4
27	9.802-427.0	Cord, Service, SOWA, 12/3 (511.0, 512.0)	2.75 ft.
	9.802-436.0	Cord, Service, SEO, 10/3 (513.0)	2.75 ft.
28	9.802-514.0	Strain Relief, Small (511.0, 512.0)	1
	9.802-518.0	Strain Relief, STRT LQ TITE (513.0)	1
29	9.802-525.0	Locknut, 1/2" (511.0, 512.0)	1
	9.802-526.0	Locknut, 3/4" 8465 (513.0)	1
30	9.803-899.0	Unloader, VBA35 LG/LD/LE 6.6 @ 3500	1
31	9.802-124.0	Plug, 1/4" Countersunk (231007D, 201507D)	1
33	9.802-2410	Hose, 3/8" x 25", 2 Wire, Pressure Loop	1
34	9.800-002.0	Label, Use Only Kerosene	1
35	9.802-871.0	Block, Discharge, 1/2" x 1/2", Brass	1
36	9.802-192.0	Disk, Rupture Assy, 7000 PSI	1
37	9.802-156.0	Hose Barb, 1/2" Barb x 3/8" MPT, Push-On	1
38	9.802-259.0	Hose, 1/2" Push-On	2.5 ft.
39	9.802-171.0	Nipple, 3/8" x 3/8" NPT ST Male	1
40	9.802-112.0	Elbow, 3/8" Female	1
41	9.800-021.0	Label, Hot Water Outlet	1
42	9.800-110.0	Label, Kärcher Logo	2
43	9.803-091.0	Wrap, Outer Coil, SS	1
44	9.802-753.0	Screw, 1/4" x 3/4" HH NC, Whiz Loc	8

EXPLODED VIEWS PARTS LIST

45	9.802-793.0	Nut, Cage, 1/4" x 16 Gauge	4
46	9.803-095.0	Coil, Assembly	1
47	9.800-041.0	Label, Warning, Text	1
48	9.800-006.0	Label, Hot/Caliete w/Arrows Warning	1
49	9.803-029.0	Tank Head Assy, 16" DIA x 8" Stack	1
50	9.802-901.0	Insulation, Tank Head, 16" OD x 8" ID	1
51	9.802-825.0	Clip, Retaining U-Type	4
52	9.802-042.0	Elbow, 1/2" JIC x 3/8" Fem, 90°	1
53	9.803-030.0	Retainer, Burner Insulation	1
54	9.802-768.0	Screw, 3/8" x 1-1/4" Whiz Loc	4
55	9.802-900.0	Insulation, Tank Bottom, 1" Blanket	1
56	9.803-120.0	Assembly, Frame, Black	1
57	9.802-754.0	Screw, 1/4" x 1/2" HH NC, Whiz Loc	8
58	9.802-285.0	Thermostat, Adjustable, 302°F	1
59	9.803-026.0	Tab, Outer Wrap	4
60	9.802-794.0	Nut, Cage, 1/4" x 12 Gauge	8
61	9.802-792.0	Nut, Cage, 3/8" x 12 Gauge	4
62	9.802-555.0	Burner, AFG, 120V, F4 Cone (511.0, 512.0)	1
	9.804-518.0	Burner, Beckett, 230V AFG (513.0)	1
63	9.802-583.0	Nozzle, Oil, HOL 1.00 A, 90° (511.0, 512.0)	1
	9.802-575.0	Nozzle, Burner, 1.75 B 90° (513.0)	1
64	9.802-781.0	Nut, 3/8" Flange, Whiz Loc, NC	4
65	9.802-424.0	Cord, Service, SEO, 16/4, Coleman	64"
66	9.802-519.0	Strain Relief, 1/2" Metal, Two Screw	1
67	9.803-264.0	Nipple, 1/4" x 3", Black Pipe	1
68	9.802-212.0	Filter, Parker Fuel/Oil/H ₂ O (10 Micron), Generic	1
69	9.802-143.0	Hose Barb, 1/4" Barb x 1/4" Pipe, 90°	1
70	9.800-020.0	Label, Cold Water Inlet	1
71	9.800-013.0	Label, Intended for Indoor Use	1
72	9.800-032.0	Label, Motor Overload Reset, Lexan	1
73	9.802-103.0	Bushing, Snap	1
74	9.802-432.0	GFCI, 120V 15A, w/36' 12-3 Cord (511.0)	1
	9.802-431.0	GFCI, 120V 20A, w/36' 12-3 Cord (512.0)	1
	9.802-430.0	GFCI, 240V 1PH 30A, w/36' 10-3 Cord (513.0)	1
75	9.800-015.0	Label, Warning, Service Cord	1
76	9.800-034.0	Label, Clear Lexan, 2-1/4" x 4-1/2"	1
77	9.802-512.0	Cable, TY, 48"	2
78	9.803-111.0	Lever, Brake	1
79	9.802-996.0	Bracket, Brake Pad	1
80	9.802-997.0	Linkage, Brake	1
81	9.802-705.0	Bolt, Carriage	4
82	9.802-773.0	Nut, 1/4" ESNA	4
83	9.802-802.0	Washer, 1/4"	12
84	9.802-908.0	Insulation, Blanket, 18" x 52", Fiberglass	1
85	9.802-709.0	Bolt, 5/16" x 3/4" NC	4
86	9.802-047.0	Adapter, 1/2" x 1/2" Pipe	1
87	9.802-041.0	Elbow, 3/8" 45°	1
88	9.802-045.0	Bushing, 1/2" x 3/8"	1
89	9.802-011.0	Nipple, 3/8" x 3/8" Hex	1
90	9.800-049.0	Label, Cleaning Solutions	1

CONTROL PANEL EXPLODED VIEW PARTS LIST

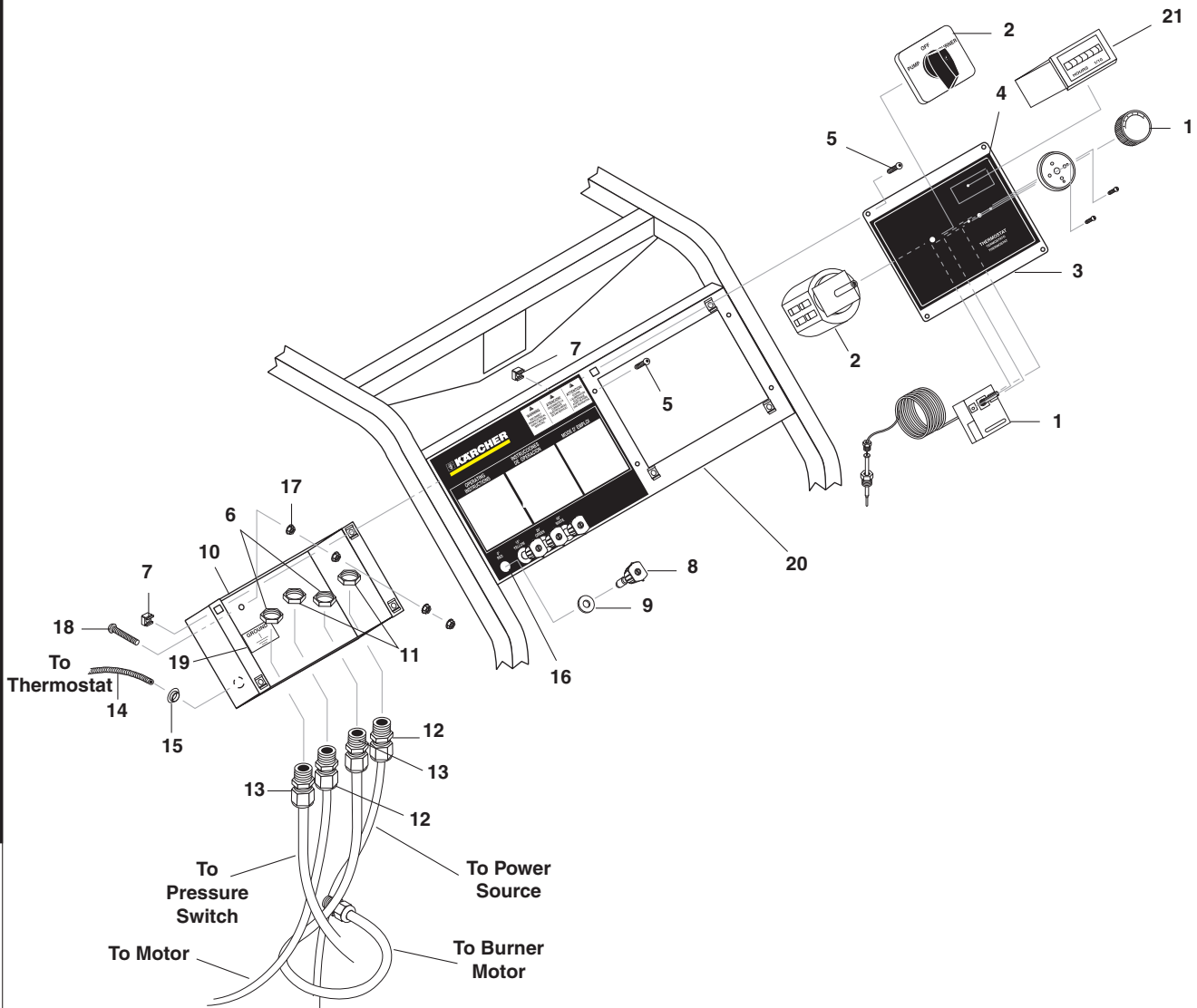

ITEM	PART NO.	DESCRIPTION		QTY
1	9.802-285.0	Thermostat, Adjustable, 302°F	4-05088	1
2	9.802-449.0	Switch, 3 PS, 115V-230V, 1PH	6-020201	1
3	9.804-519.0	Cover, Electric Box, Black	95-07104970	1
4	9.804-520.0	Label, Electric Box	11-0319	1
5	9.802-7590	Screw, 10/32" x 1/2" BHSOC Blk	90-1991	8
6	9.802-525.0	Locknut, 1/2"	6-05181A	2
7	9.802-791.0	Nut, Cage, 10/32" x 16 Gauge	90-2018	8
8	See Page 17	Nozzle		4
9	9.802-064.0	Grommet, Rubber, Nozzle Holder	2-0103	4
10	9.804-521.0	Box, Electric, black	95-07104969	1
11	9.802-525.0	Locknut, 1/2" (511.0, 512.0)	6-05181A	2
	9.802-524.0	Locknut, 1/2" Conduit (513.0)	6-05181	2
12	9.802-514.0	Strain Relief, STRT, LQ TITE Small (511.0, 512.0)	6-05152	2
	9.804-522.0	Strain Relief, 12/4 Alum. (513.0)	6-0522	2
13	9.802-514.0	Strain Relief, STRT LQ TITE	6-05152	2

CONTROL PANEL PARTS LIST

ITEM	PART NO.	DESCRIPTION		QTY
14	9.802-447.0	Conduit, Corr, Tubing, 1/4"	6-01270	2 ft.
15	9.802-103.0	Bushing, Snap, 5/8"	2-01403	1
16	9.804-526.0	Label, Control Panel, Kärcher	11-0317	1
17	9.802-695.0	Nut, 10/32" Keps	90-017	4
18	9.802-762.0	Screw, 10/32" x 1-1/4"	90-1994	1
19	9.800-040.0	Label, Ground	11-1042	1
20	9.804-524.0	Panel, Control, Black	95-07104971	1
	9.802-754.0	▲ Screw, 1/4" x 1/2" HH, NC, Whiz Loc	90-19711	4
	9.802-775.0	▲ Nut, 1/4" Flange	90-200012	4
21	9.802-283.0	Hour Meter	4-050822	1

▲ Not Shown

HOSE AND SPRAY GUN EXPLODED VIEW

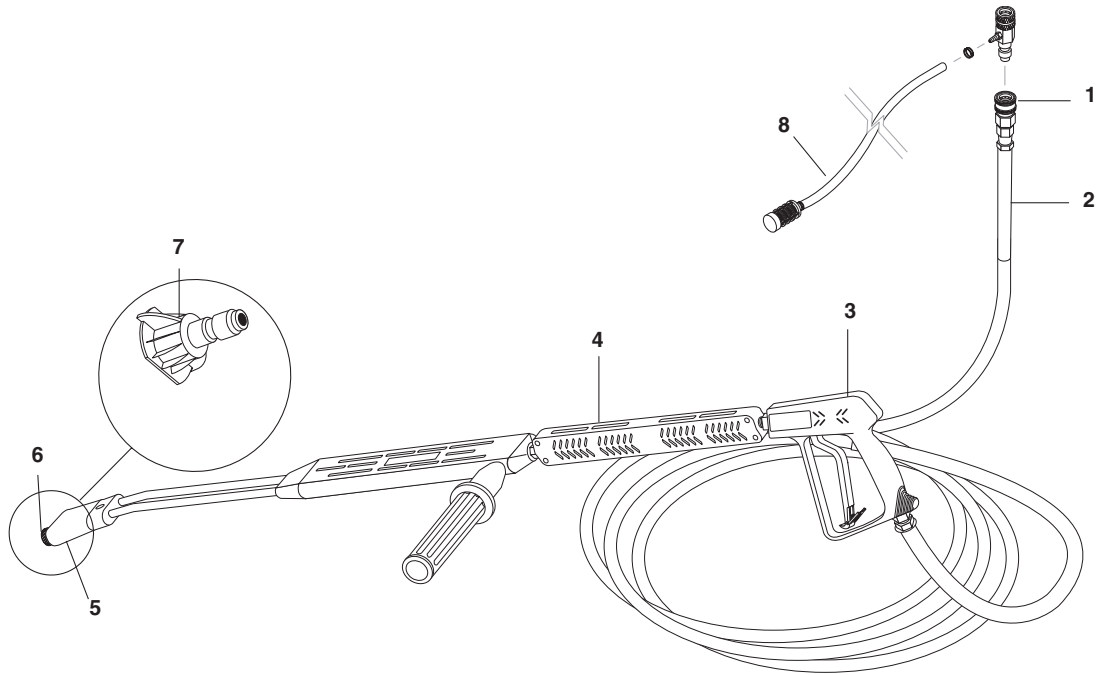

HOSE AND SPRAY GUN PARTS LIST

ITEM	PART NO.	DESCRIPTION	QTY
1	9.802-166.0	Coupler, 3/8" Female	1
	9.802-100.0	▲ Quick Coupler O-Ring LG	1
2	9.802-233.0	Hose, 50' x 3/8", 1 Wire, w/Coupler	1
3	9.802-229.0	Spray Gun, Shutoff, AP 1000	1
4	9.802-222.0	Wand, VP Zinc 1/4" w/Coupler, w/Soap Nozzle	1
	9.803-267.0	▲ AL Wand Repair Kit, Stainless Seat	1
5	9.802-286.0	Brass Soap Nozzle Only, 1/8"	1
6	9.802-165.0	Coupler, 1/4" Male	1
	9.802-096.0	▲ Quick Coupler O-Ring Sm	1
7	9.802-287.0	Nozzle SAQMEG 0003, Red (512.0)	1
	9.802-288.0	Nozzle, SAQMEG 1503, Yellow (512.0)	1
	9.802-289.0	Nozzle SAQMEG 2503, Green (512.0)	1
	9.802-290.0	Nozzle, SAQMEG 4003, White (512.0)	1
	9.802-295.0	Nozzle, SAQMEG 0004, Red (511.0)	1
	9.802-296.0	Nozzle, SAQMEG 1504, Yellow (511.0)	1
	9.802-297.0	Nozzle, SAQMEG 2504, Green (511.0)	1
	9.802-298.0	Nozzle, SAQMEG 4004, White (511.0)	1
	9.802-299.0	Nozzle, SAQMEG 0005, Red (513.0)	1
	9.802-300.0	Nozzle, SAQMEG 1505 Yellow (513.0)	1
	9.802-301.0	Nozzle, SAQMEG 2505, Green (513.0)	1
	9.802-302.0	Nozzle, SAQMEG 4005, White (513.0)	1
8	9.802-224.0	Detergent Injector Assy, 2-3 GPM, 0.70" (511.0, 512.0)	1
	9.802-225.0	Detergent Injector Assy, 3-5 GPM, 0.83 (513.0)	1

▲ Not Shown

DOWNSTREAM INJECTOR EXPLODED VIEW

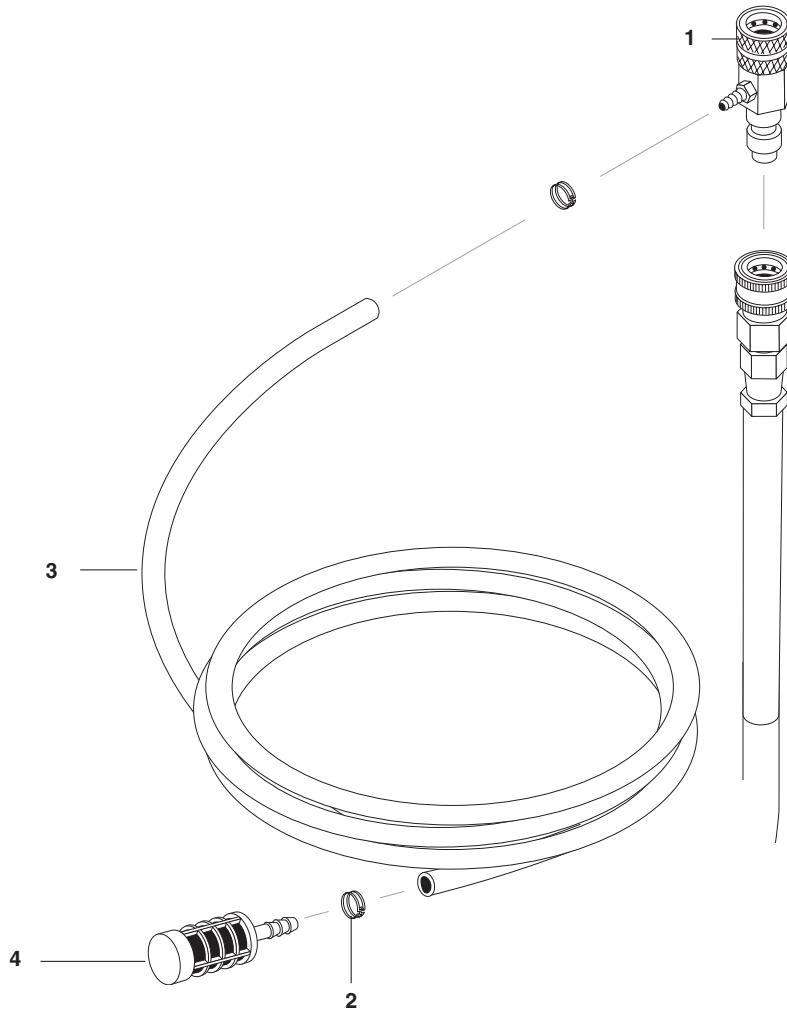

DOWNSTREAM INJECTOR PARTS LIST

ITEM	PART NO.	DESCRIPTION	QTY
1	9.802-215.0	Injector, Detergent, Non-Adjust #2 (511.0, 512.0)	1
	9.802-216.0	Injector, Detergent, Non-Adjust #3 (513.0)	1
2	9.802-210.0	Clamp, Hose, UNI .46 - .54	2
3	9.802-251.0	Tube, 1/4" x 1/2", Clear Vinyl	6 ft.
4	9.802-160.0	Strainer, 1/4" Hose Barb	1

9.803-899.0 VBA35 UNLOADER EXPLODED VIEW

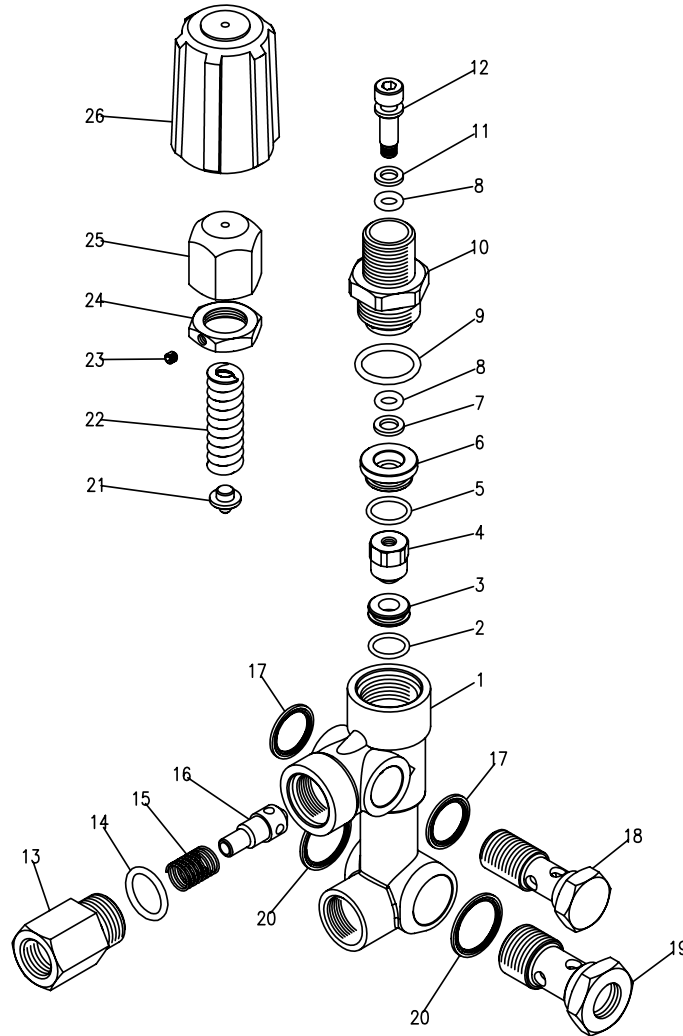

9.803-899.0 VBA35 UNLOADER PARTS LIST

ITEM	PART #	DESCRIPTION	KIT	QTY	ITEM	PART #	DESCRIPTION	KIT	QTY
1	70-020444	Body Valve		1	16	70-110207	Poppet	B	1
	70-020452	Body Valve		1	17	70-140802	Seal Washer 3/8		2
2	70-060141	O-Ring	A, C	1	18	70-180004	Hollow Bolt, 3/8		1
3	70-150316	Seat	C	1	19	70-180008	Hollow Bolt 1/2		1
4	70-450401	Ball, Sub-assy	C	1	20	70-140803	Seal Washer 1/2		2
5	70-060114	O-Ring	A	1	21	70-120212	Plate	C	1
6	70-010111	Guide Bushing		1	22	70-090037	Spring	C	1
7	70-000919	Teflon Ring	A	1	23	70-180304	Set Screw		1
8	70-060170	O-Ring	A	2	24	70-030209	Nut		1
9	70-060162	O-Ring	A	1	25	70-090520	Brass Handle		1
10	70-140734	Connector		1					
11	70-000918	Teflon Ring	A	1	Kit A	70-262813	O-Ring Repair Kit		
12	70-120611	Stem	C	1	Kit B	70-262814	Outlet Kit		
13	70-140702	Connector, Female		1	Kit C	70-262815	Stem Repair Kit		
14	70-060119	O-Ring	A, B	1					
15	70-090004	Spring	B	1					

KE SERIES PUMP EXPLODED VIEW KE 2020S, KE 3525F

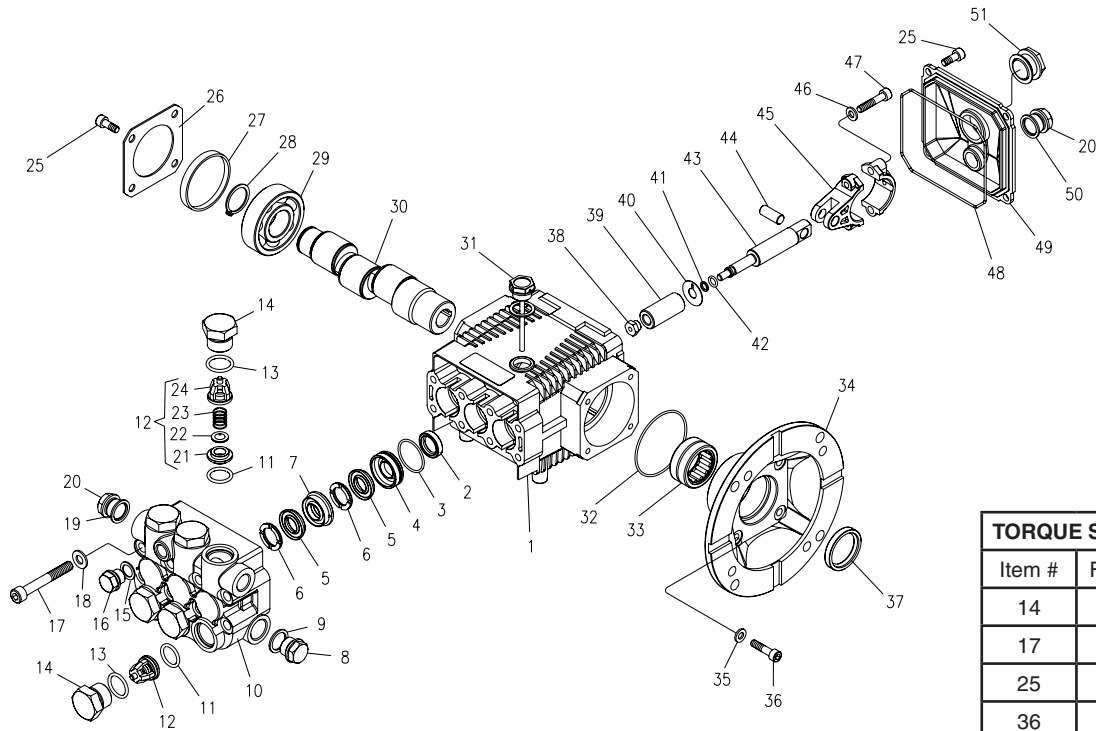

TORQUE SPECS	
Item #	Ft. -lbs.
14	65
17	22
25	8
36	8
38	9
47	13

KE SERIES PUMP PARTS LIST

ITEM	PART NO.	DESCRIPTION	QTY	ITEM	PART NO.	DESCRIPTION	QTY
1	70-020292	Crankcase	1	16	70-160121	Brass Plug G1/4	1
2*	70-000105	Plunger Oil Seal	3	17	70-180118	Manifold Stud Bolt	8
3*	70-060181	O-Ring Ø 1.78 x 28.30	3	18	70-140001	Washer	8
4*	70-120131	Pressure Ring 15mm	3	19	70-060306	Copper Washer 3/8	1
	70-120132	Pressure Ring 18mm	3	20	70-160117	Brass Plug G3/8	2
5*	70-000207	"V" Seal, dia 15mm	6	25	70-180112	Screw	12
	70-000208	"V" Seal, dia 18mm	6	26	70-020318	Bearing Cover	2
6*	70-030048	Support Ring 15mm	6	27	70-020502	Bearing Seal	1
	70-030050	Support Ring 18mm	6	28	70-150003	Snap Ring	1
7*	70-030049	Intermed Ring 15mm	3	29	70-021300	Ball Bearing	2
	70-030051	intermed Ring 18mm	3	30	70-000600	Crankshaft (2020F)	1
8*	70-160120	Brass Plug G1/2	1		70-000601	Crankshaft (2020S)	1
9	70-060307	Copper Washer 1/2"	1		70-000602	Crankshaft (2825F)	1
10	70-160228	Manifold Housing	1		70-000603	Crankshaft (2825S)	1
11	70-060155	O-Ring Ø1.78 x 15.54	6		70-000604	Crankshaft (3525F)	1
12*	See Kit Below	Valve Assembly	6	31	70-160012	Oil Dipstick	1
13*	70-060122	O-Ring Ø2.62 x 18.77	6	32	70-060183	O-Ring Ø3.53 x 55.56	1
14	70-160147	Valve Plug	6	33	70-020011	Needle Bearing	1
15	70-060308	Copper Washer 1/4	1	34	70-050095	Motor Flange 56C	1

KE SERIES PUMP PARTS LIST

ITEM	PART NO.	DESCRIPTION	QTY
35	70-140002	Washer	4
36	70-180126	Flange Screw	4
37	70-000104	Crankshaft Seal	1
38*	70-030211	Plunger Nut	3
39*	70-120023	Plunger 15mm (2020F, 2825F, 3525F)	3
	70-120022	Plunger 18mm (2020S, 2825S)	3
40*	70-140027	Copper Spacer	3
41*	70-160130	O-Ring Ø1.78 x 5.28	3
42*	70-000913	Teflon Ring	3
43	70-000320	Plunger Rod	3
44	70-1502.04	Connecting Rod Pin	3
45	70-010008	Connecting Rod	3
46	70-140102	Spring Washer	6
47	70-180132	Connecting Rod Screw	6
48	70-060104	O-Ring Ø2.62 x 107.62	1
49	70-020352	Crankcase Cover	1
50	70-060302	Gasket	1
51	70-070005	Sight Glass	1

REPAIR KIT INFORMATION

REPAIR KIT NUMBER	70-261408	70-261410	70-261409	70-261411	70-261404	70-261405	70-260028	70-260826
KIT DESCRIPTION	Plunger Seal 15mm KE 2020F KE 2825F KE 3525F	Plunger Seal 18mm KE 2020S KE 2825S	Complete Seal Packing 15mm KE 2020F KE 2825F KE 3525F	Complete Seal Packing 18 mm KE 2020S KE 2825S	Plunger 15mm KE 2020F KE 2825F KE 3525F	Plunger 18mm KE 2020S KE 2825S	Complete Valve	Plunger Oil Seals
ITEM NUMBERS INCLUDED	3, 5, 6	3, 5, 6	2, 3, 4, 5, 6, 7	3, 4, 5, 6, 7, 8	38, 39, 40, 41, 42	38, 39, 40, 41, 42	11, 12, 13	2
NUMBER OF CYLINDERS KIT WILL SERVICE	3	3	1	1	1	1	6	3

TROUBLESHOOTING

PROBLEM	POSSIBLE CAUSE	SOLUTION
LOW OPERATING PRESSURE	Faulty pressure gauge	Install new gauge.
	Insufficient water supply	Use larger garden hose; clean filter washer at water inlet.
	Old, worn or incorrect spray nozzle	Match nozzle number to machine and/or replace with new nozzle.
	Plumbing or hose leak	Check plumbing system for leaks. Re-tape leaks with teflon tape.
	Faulty or mis-adjusted unloader valve (where applicable)	Adjust unloader for proper pressure. Install repair kit when needed.
	Worn packing in pump	Install new packing kit.
	Fold or dirty inlet or discharge valves in pump	Clean inlet or discharge valves.
DETERGENT NOT DRAWING	Worn inlet or discharge valves	Replace with valve kit.
	Air leak	Tighten all clamps. Check detergent lines for holes.
	Valve in the injector head may be blocked, dirty, or damaged	Clean or replace valve in injector.
	Filler screen on detergent suction hose plugged	Clean or replace.
	Dried up detergent plugging metering valve	Disassemble and clean thoroughly.
	High viscosity of detergent	Dilute detergent to specifications.
	Hole in detergent line(s).	Repair hole.
PUMP RUNNING NORMALLY BUT PRESSURE LOW ON INSTALLATION	Low detergent level	Add detergent if needed.
	Discharge water temperature above 180° F	Lower discharge water temperature.
	Pump sucking air	Check water supply and possibility of air
	Valves sticking	Check and clean or replace if necessary.
	Unloader valve seat faulty	Check and replace if necessary
FLUCTUATING PRESSURE	Nozzle incorrectly sized	Check and replace if necessary (see serial plate for proper size).
	Worn piston packing	Check and replace if necessary.
	Valves worn	Check and replace if necessary.
	Blockage in valve	Check and replace if necessary.
PUMP NOISY	Pump sucking air	Check water supply and air see page at joints in suction line.
	Worn piston packing	Check and replace if necessary.
	Air in suction line	Check water supply and connections on suction line.
	Broken or weak inlet or discharge valve springs	Check and replace if necessary.
LOW WATER TEMPERATURE	Excessive matter in valves	Check and clean if necessary.
	Worn bearings	Check and replace if necessary.
	Improper fuel or water in fuel	Drain fuel tank and replace with proper fuel.
	Low fuel pressure	Increase fuel pressure.
	Weak fuel pump	Check fuel pump temperature. Replace pump if needed.
	Fuel filter partially clogged	Replace as needed.
	Soot build up on coils	Clean coils with soot remover.
WATER TEMPERATURE TOO HOT	Lime build up on coils	Clean inside of coils using coil cleaner.
	Improper burner nozzle	Call technical service for proper size.
	Incoming water to machine warm or hot	Lower incoming water temperature.
	Fuel pump pressure too high	Lower fuel pressure.
	Fuel pump defective	Replace fuel pump.
	Detergent line sucking air	Tighten all clamps. Check detergent line for holes.
	Defective high limit switch (thermostat)	Replace.
Insufficient water supplied	Check GPM to machine.	
Restricted water flow	Check nozzle for obstruction, proper size.	

MAINTENANCE SCHEDULE

PREVENTATIVE MAINTENANCE

This pressure washer was produced with the best available materials and quality craftsmanship. However, you as the owner have certain responsibilities for the correct care of the equipment. Attention to regular preventative maintenance procedures will assist in preserving the performance of your equipment. Contact your local pressure washer dealer for maintenance. Regular preventative maintenance will add many hours to the life of your pressure washer. Perform maintenance more often under severe conditions.

MAINTENANCE SCHEDULE		
Replace Fuel Lines		Annually
Pump Oil	Inspect	Daily inspect the oil level
	Change	After first 50 hours, then every 500 hours or annually
Clean Burner Filter		Monthly (more often if fuel quality is poor)
Remove Burner Soot		Annually
Burner Adjustment/Cleaning		Annually
Descale Coil		Annually (more often if required)
Replace High Pressure Nozzle		Every 6 months
Replace Quick Connects		Annually
Clean Water Screen/Filter		Weekly
Clean Float/Supply Tank		Every 6 months
Replace HP Hose		Annually if there is any sign of wear
Grease Motor		Every 10,000 hours
Replace Burner Nozzle		Annually

OIL CHANGE RECORD

Date Oil Changed Month/Day/Year	Estimated Operating Hours Since Last Oil Change

Date Oil Changed Month/Day/Year	Estimated Operating Hours Since Last Oil Change

**LIMITED NEW PRODUCT
WARRANTY—COMMERCIAL
PRESSURE WASHERS**



Phone: 888-805-9852
Fax: 800-248-8409
www.karchercommercial.us

PRESSURE WASHER WARRANTY

WHAT THIS WARRANTY COVERS

All Kärcher commercial pressure washers are warranted by Kärcher to the original purchaser to be free from defects in materials and workmanship under normal use, for the periods specified below. This Limited Warranty, subject to the exclusions shown below, is calculated from the date of the original purchase, and applies to the original components only. Any parts replaced under this warranty will assume the remainder of the pressure washer's warranty period.

FIVE YEAR PARTS AND ONE YEAR LABOR WARRANTY

Components manufactured by Kärcher, such as frames, handles, float tanks, fuel tanks, belt guards, and heating coils. Internal components on the oil-end of Kärcher pumps have a 5 year warranty. Heating coils are pro-rated at 25% after 2 years. Stainless steel coils have a 10 year warranty.

ONE YEAR PARTS AND ONE YEAR LABOR WARRANTY

All other components, excluding normal wear items as described below, will be warranted for one year on parts and labor. Parts and labor warranty on these parts will be for one year regardless of the duration of the original component manufacturer's part warranty.

WARRANTY PROVIDED BY OTHER MANUFACTURERS

Motors, generators, and engines, which are warranted by their respective manufacturers, are serviced through these manufacturers' local authorized service centers. Kärcher is not authorized and has no responsibility to provide warranty service for such components. Motors manufactured outside of the United States will be warranted by Kärcher.

WHAT THIS WARRANTY DOES NOT COVER

This warranty does not cover the following items:

1. Normal wear items, such as nozzles, spray guns, discharge hoses, wands, quick couplers, seals, filters, gaskets, O-rings, packings, pistons, pump valve assemblies, strainers, belts, brushes, rupture disks, fuses, pump protectors.
2. Any components or other devices incorporated into a Kärcher product that are not manufactured by Kärcher, including, but not limited to gasoline engines, pumps, etc.
3. Defects caused by improper or negligent operation or installation, accident, abuse, misuse, neglect, unauthorized modifications, repair or maintenance of the product by persons other than authorized representatives of Kärcher, including, but not limited to, the failure of the Customer to comply with recommended product maintenance schedules.
4. Kärcher products that have been returned by the original Customer and are ultimately re-sold by an Authorized Servicing Dealer or other sales or service outlet to another purchaser.
5. Kärcher products that are sold by any distributor or retailer that is not an official authorized dealer or retailer of Kärcher products.
6. Defects caused by acts of nature and disaster including, but not limited to, floods, fires, wind, freezing, earthquakes, tornadoes, hurricanes and lightning strikes.
7. Defects caused by water sediments, rust corrosion, thermal expansion, scale deposits or a contaminated water supply (such as water in the unit with chloride content higher than that of 80 mg/liter or use of chemicals not approved or recommended by Kärcher).
8. Defects caused by improper voltage, voltage spikes or power transients in the electrical supply.
9. Devices or accessories not distributed or approved by Kärcher.
10. Any cost of labor arising from the removal and reinstallation of the alleged defective part by Customer.
11. Transportation of the product to an Authorized Servicing Dealer, field labor, replacement rental and any freight charges.

Any components, accessories or other devices provided with the product but not manufactured by Kärcher (such as engines, pumps, etc.) are subject to warranties and service through their respective manufacturers authorized service centers and according to the applicable terms and conditions of such manufacturers warranties. Such components or other devices not manufactured by Kärcher should be referred by the Customer to an authorized service center or their respective manufacturers for repair or replacement.

THE FOREGOING WARRANTY IS IN LIEU OF ALL OTHER WARRANTIES OF ANY KIND, WHETHER ARISING BY LAW, CUSTOM OR CONDUCT. KÄRCHER MAKES NO ADDITIONAL WARRANTIES, EITHER EXPRESSED OR IMPLIED, INCLUDING, WITHOUT LIMITATION, ANY EXPRESSED OR IMPLIED WARRANTIES OF MERCHANTABILITY OR FITNESS OF EQUIPMENT FOR A PARTICULAR PURPOSE AND ANY SUCH WARRANTIES ARE EXPRESSLY DISCLAIMED. KÄRCHER FURTHER DISCLAIMS ANY WARRANTY THAT THE PRODUCT PURCHASED BY CUSTOMER WILL MEET ANY PARTICULAR REQUIREMENT OF CUSTOMER EVEN IF KÄRCHER HAS BEEN ADVISED OF SUCH REQUIREMENT.

THE RIGHTS AND REMEDIES PROVIDED UNDER THIS WARRANTY ARE EXCLUSIVE AND IN LIEU OF ANY OTHER RIGHTS OR REMEDIES OF CUSTOMER. KÄRCHER SHALL NOT UNDER ANY CIRCUMSTANCES BE LIABLE TO ANY PERSON OR ENTITY INCLUDING, BUT NOT LIMITED TO, THE CUSTOMER OR ANY END USER OF THE PRODUCT FOR ANY SPECIAL, INDIRECT, INCIDENTAL OR CONSEQUENTIAL DAMAGES OR ECONOMIC LOSS, LOSS OF PROFITS OR LOSS OF USE OF THE PRODUCT, ARISING IN CONNECTION WITH THE SALE, DELIVERY, INSTALLATION, TRAINING OR USE OF PRODUCT.

KÄRCHER'S LIABILITY, WHETHER IN CONTRACT OR IN TORT, ARISING OUT OF ANY WARRANTIES OR REPRESENTATIONS, INSTRUCTIONS OR DEFECTS FROM ANY CAUSE, SHALL BE LIMITED EXCLUSIVELY TO THE COST OF REPAIR OR REPLACEMENT PARTS UNDER AFORESAID CONDITIONS.

The purpose of the foregoing limitations on liability and Customer remedies is to protect Kärcher from unknown or undeterminable risks. Some states do not allow the exclusion or limitation of incidental or consequential damages, so the above limitation or exclusion may not apply to the Customer.

Kärcher sales and service representatives are not authorized to waive or alter the terms of this warranty, or to increase the obligations of Kärcher under the warranty.

Kärcher reserves the right to make design changes in any of its products without prior notification to the Customer.



Form #9.800-191.0 • Revised 2/06 • Printed in U.S.A.