

Telephone (clubhouse): 8712 7755 Club email: bdwwcsec@outlook.com

Postal address:

**The Berwick District Woodworkers Club Inc
PO Box 921, Berwick, Victoria, 3806**

Location:

**The Old Cheese Factory, 34 Homestead Road Berwick, 3806
Inc. No A0012122U
Welcome to the Newsletter for April 2026**

DATES TO REMEMBER: Committee Meeting – Wednesday 13th May 2026 - 1:00pm in clubroom. **General Meeting** - Wednesday, 17th June, 1:00pm in clubroom. As always it will be preceded by a free BBQ lunch at 12 noon. Hope to see you there.

PRESIDENT'S MESSAGE.



This month finds the preparations for this year's expo progressing well. Last month saw 11 members of our club attend the annual Turnfest in Queensland. With demonstrators both from Australia and Overseas and 285 participants it was a melting pot of techniques and an opportunity for everyone to learn and share ideas. Socially a good time was had by all club members. On Thursday 23rd April, we have the club luncheon at the Cardinia Club, Pakenham. Last Saturday was the Farmers Market and although we had a pretty good result, considering the weather, the numbers of members to help was well down. The market is our main fundraiser and this is the main reason our fees continue to be very low. But

we need more help once a month on the Saturday morning. It would be great to have a better representation from our newer members, even if just for an hour or two. If Saturdays are the only day you can attend the club just give us some of your time and then spend some time in the workshop. These markets are our main source of income. Without this income our fees would have to go up a lot, and a lot of the things members enjoy for free would have to be paid for.

Unfortunately I have to go back to the continuing problem with cleaning up after ourselves and the lack of care for the sand paper on the sanding machines. Cleaning up has improved but can still be better. Unfortunately, the issue with the sanding machines has not. The paper needs to be cleaned regularly if you are sanding a lot as well as at the end. And if you only sand a little bit still clean it so it is clean for the next person. There is no point raising the platform on the bigger belt sander because you want a nice clean bit of sand paper, if everyone does that very soon it is a very narrow sanding area instead of quite a wide one. Don't be offended if someone reminds you about these things as it is not them that is doing the wrong thing. We had to change another pad on a disc sander on Monday which was only a week old, because it was ruined by misuse. This is why we need the income from the markets and the vouchers we get from our Bunnings evenings, but it is not sustainable if we don't look after our equipment.

Two of our hard-working members are relinquishing their positions in our club. **Don** will be passing on the secretary's job at the AGM in August and we thank Don for his hard work. **Elsie** has been the Editor of the Newsletter for approximately 18 years and will finish after the April Newsletter. This is an outstanding effort and we thank her for her contribution to the club in this role.

If we have anyone who would be interested in doing either of these jobs, please let someone on the committee know.

Regards **Ian Deans.**

CLUB INFORMATION

MEETINGS:

COMMITTEE

Wednesday 13th May 1:00pm

GENERAL

Wednesday 17th June 1:00pm

MARKETS – Volunteers needed

Saturday 9th May - Farmers Market

Newsletter Contributions

All material for the Club's monthly publication is to be submitted by e-mail to ricels@bigpond.com, by hand, or by phone to Elsie Hoare the editor by the 15th of each month. Letters to the editor must be sent to the committee.

Committee of Management:

Position	Name	Phone
President	Ian Deans	0403 419 774
Vice President	Ron Bolton	0413 152 391
Secretary	Don Buchanan	0431 313 998 email: bdwwsec@outlook.com
Treasurer	Peter Ball	0425 725 875

Committee	Phone
John McMahan	0437 096 840
Ken Whitefield	0402 256 134
Michael Berry	0466 812 717
Peter Mason	0419 531 524
Simon King	0477 831 318
David Macgregor	0490 897 630
Julie Robinson	0481 088 390
Carol Goddard	0422 395 565

Contacts

Equipment authorisation approved members – *Ian Deans, Don Buchanan, Simon King, and Ron Bolton.*

Health and Safety Coordinator – *Ron Bolton*

Machinery Maintenance Coordinators. - *Ron Bolton & Simon King*

Timber Coordinator – *Ken Whitefield*

Screws – *Ken Whitefield*

Paint – *Ken Whitefield*

Toy Coordinators – *Ian Deans & Julie Robinson*

Functions Coordinator - *Don Buchanan*

Gala Day Coordinator – *Ian Deans*

Annual Expo - *John McMahan & Jayne Worthington*

Farmers Market Coordinators – *Ian Deans & Don Buchanan*

Public Relations - *Don Buchanan*

OCF Contacts – *Ian Deans & Ron Bolton*

Webmaster - *Ron Bolton*

Newsletter Editor - *Elsie Hoare*

Members' Welfare Coordinator - *Ken Whitefield*

Men's Shed Coordinator - *Wayne Lucas*

Membership Fees:

	Joining	Annual
Individual	\$50.00	\$75.00
Family of 2	\$75.00	\$115.00
Family of 3	\$75.00	\$138.00
Family of more than 3 please enquire.		
No Attendance Fee.		
Tea & Coffee complimentary.		

Paying your Membership Fees

Members can pay either direct at club or by EFT bank transfer to WBC Berwick BSB 033 609, Acct # 41 6074. Please remember to put your surname as a reference.

Safety First

For safety reasons, there must always be **three** members present whenever the workshop is being used.

Clubrooms and Workshops Open Hours

Weekly	Hours	Leader
Monday	9:00 am – 1:00 pm	Ron Bolton
Tuesday	9:00 am – 1:00 pm	Michael Berry
Wednesday	9:00 am – 4:00 pm	Don Buchanan
Wednesday Evening	4:00 pm – 7:00 pm	Ian Deans & David Macgregor.
Thursday	9:00 am – 1:00 pm	Brian Crowe
Friday	9:00 am – 1:00 pm	Ron Bolton
Saturday	9:00 am – 1:00 pm	Ron Bolton

Berwick Woodworkers wish to thank **Gary Maas MP** State Member for Narre Warren South, and his staff for their ongoing support in printing this newsletter for us.



As Club President, **Ian Deans** has already mentioned, the maltreatment of our sanding equipment is a continual cause for concern. Clogged or damaged sanding discs and belts are of little use to anyone and are very expensive to replace, so we are expected to treat them with respect. There are plenty of cleaning blocks available and it takes no more than a few seconds to use one when we have finished with the machine. If you enjoy the pleasure of using clean sandpaper, please be kind enough to think of the next club member and leave it in a clean state for them. The sorry sight, pictured below, greeted a club member one Monday morning recently. The left-overs from someone else's mess with a belt that had to be cleaned before it could be used and a damaged disc that had to be replaced. A frustrating start to the morning for that member.



On a happier note: Also mentioned by Ian, here we see the group of club members who attended the annual Turnfest event in Queensland. Many thanks to **Don Buchanan** for the photo. Here's what Don had to say.



“Down the left - **John Mc Mahon, Ian Deans, Heather Deans, Simon King, Christine King, Me** at the top of the table, **Heather Buchanan, Margaret Clayton, Bill Clayton David Macgregor and Kim Macgregor.** All enjoying our gourmet buffet meal.”



On another happy occasion, club members gathered in the clubroom to help **Jillian Drysdale** celebrate **Alexander Drysdale's 90th** birthday. Who would have thought it? At left is the birthday boy with his birthday cake and 9 candles to represent each of Alexander's 9 decades. And at right is Alexander with Jillian (wearing a fun tammy with fake hair). Below are some of the club members who came along to help the couple celebrate.





It's been a busy month for Berwick Woodworkers. **Jillian Drysdale** explains the picture at left.

Here we are representing the Club at a function at Myuna Farm in Doveton. It was for Windemere Child and Family services, who are also recipients of some of the wonderful wooden toys at Christmas.

As well as our offerings of egg, bacon, sausages in bread with sauce; there were ice-cream cones, donuts, coffee and soft drinks.

Also a jumping castle. Ken did take off his shoes and got in the queue. Alas, he was too tall so came back and cooked the bbq instead.

Plenty of kids activities and at 1.30 a Myuna Farm staff person came to visit with furry

bunnies, a guinea pig and a small rare chicken. Thankfully no reptiles.

A great day in the autumn sunshine.

Pictured are **Ken Whitefield, Di Housiaux, Hayden Everwood and Jillian Drysdale**. Thanks for the photo, **Don Buchanan**.

Meanwhile, **Brian Roberts** has been busy with the lathe. Here are some bowls Brian has made as gifts, with the bottom of each laser engraved for the occasion.

Brian says, "*Dave Macgregor's amazing laser work on the bowls I made. Thanks Dave, much appreciated mate.*"

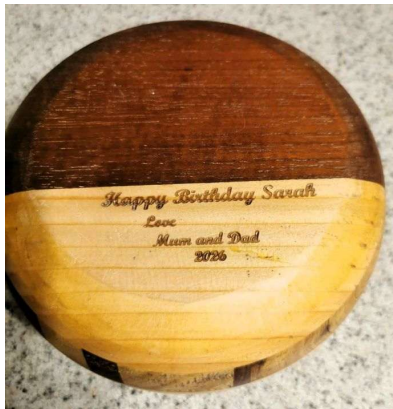

Brian has also made the back scratcher shown below as a gift for Esther.



Best Wishes. To those of our members who are unable to join us these days, due to their own ill health or that of a loved one, we send our best wishes and hope that you will soon be on the mend.





SHOW & TELL:

Stephen Gartlan showed us his segmented bowl of various woods.

Jayne Worthington made the charcuterie serving boards at right using resin and pebbles with model makers grass for trees in one and Autumn leaves in the other.



John McMahon made the textured oak bowl with pyrography detailing, below left. The bowls below right are also by John. The bowl directly below is natural edge hakea and the one below that is textured hakea.



Brian Crowe has made another of his cars. This one is a model of the 1914 Rolls Royce Silver Ghost, using cypress and red gum. There is also a street lamp and a petrol pump which had a little help from **Ross Blackwood** who used the club's laser engraver for the lettering on the pump.





Aaron Zong showed us his pen sets.

At left, fountain pen, roller ball pen & letter opener in compressed Africa Padauk with 22 carat gold & crystal.



At right fountain pen, roller ball pen and letter opener in stabilised burl (gum) with 22 carat gold and crystal.



IT'S NOT ALL WOODWORK: We, at Berwick Woodworkers, have some first-class machinery at our disposal, which saves us a lot of time and effort, helping us to turn out something of which we can be proud. These mechanical wonders need regular attention and we are fortunate that we have some knowledgeable members among us who did not leave their professional skills behind them when they joined us. Here are three such members working on solving a problem that has occurred with our router. That's **Collin Ellard**, **Brian Crowe** and **Ross Blackwood**, joining forces to persuade the troublesome part of the router to work properly again.



Many thanks to all those members who are so generous with their time and ability.

Thanks again to our sponsors for their continued support throughout the year.



EXPO NEWS: from John McMahon.

Organising for this year's Expo is well under way, and there's a surprisingly short time until it arrives, so I hope everyone is working diligently to get their exhibition pieces completed. Remember that this is an exhibition of our members' work, meant to display all levels of expertise from beginner to experienced artisan, so don't ever feel that your work is not good enough. This year we are making a feature display of pens, which don't all have to be made on the lathe, or made round. They can be carved, turned, hand-shaped, CNC'd, or whatever. Use your imagination.

Entry forms are now available in the clubrooms. Completed entry forms can be left in the plastic tray next to them. Entries close on Friday 26th June, but the earlier they are received, the easier it is to arrange all the paperwork and display card printing, rather than having to do all this at the last minute. Delivery of your pieces is required between 3rd & 6th July, from 9am to 12 noon daily.

There are 2 different entry forms. The "Exhibition" entry form (printed in Landscape) is for pieces that have not been displayed previously in our Expo, and there is a limit of 30 items per entrant. You have the choice of offering these for sale or not. If you have pieces that have been displayed in earlier Expo's that you would like to sell, the "Sales Only" entry form (printed in Portrait) is the one to use. There is a limit of 50 items per entrant here. Remember that all sales will attract a 15% commission to the Club, so price your pieces to reflect this please.

Rosters for manning the various demonstration stations and the reception and sales counters during the Expo are also displayed in the clubrooms. We need lots of volunteers to make themselves available, so please take the time to check these out and add your name.

Our raffle tickets have been printed and are being sold at the Farmers Market. They are also available for members to take and sell, but Government regulations require us to keep certain records. So please see Don Buchanan or one of the Committee, and record your name on the ticket register before taking a book thanks. Our flyers have also been printed and are starting to be distributed, beginning with a targeted distribution to the Club's suppliers now. From the beginning of June we will target local businesses in Casey and Cardinia, so we will need members to distribute them to local coffee shops, businesses, retirement & lifestyle villages, etc., and from the end of June, we will target letterbox drops so all hands will be needed then. A clean up working bee of the clubrooms and workshop will be held on Thursday 2nd July followed by a barbeque lunch. Lots of hands are needed for this please. Use of the workshop for members to use the tools and machinery will be restricted from then until after the Expo, returning to business as usual on Tuesday 14th July, and as exhibition pieces are received, access to parts of the clubrooms may also be impacted.

In the meantime, members of the Expo Sub-committee will be busy making sure that all the infrastructure required to present the Expo is organized, such as the display card stands, exhibition plinths, clean table cloths, tables, signage, catering, lucky dip prize preparation, etc., so please be receptive to any requests for help you may receive.

Remember that this Expo is the time that we get to show our great club to the world. In addition to our local community, we regularly get visitors from wood clubs and Men's Sheds from across Victoria and other States, and our event is generally regarded as one of the best around. This year we celebrate our 40th birthday, and are hosting the biennial Australian Scroll Saw Exhibition as well, so get busy with your entries and let's make this year's Expo an exceptional one.

Cheers, **John.**

City of Casey BERWICK DISTRICT WOODWORKERS CLUB Inc.

Join us to celebrate
BERWICK DISTRICT
WOODWORKERS CLUB's
40th BIRTHDAY

**Woodworking
Display & Expo**

also hosting
The Australian
Scroll Saw Network
Biennial Exhibition

FREE ENTRY

JOIN US FOR OUR
40th Birthday
CELEBRATION!

(Children under 16 to be accompanied by an adult please)

Friday 10 July 2026	5.00pm—8.00pm
Saturday 11 July 2026 and Farmers' Market	9.00am—5.00pm 8.00am—1.00pm
Sunday 12 July 2026	9.00am—5.00pm

The Clubrooms
The Old Cheese Factory
34 Homestead Road
Berwick

Got questions? Reach out!
John McMahon: 0437 096 840 or Jayne Worthington: 0409 991 356
email: bdwwcsec@outlook.com www.bdwwc.club
Scan QR Code for further details

Image Credits: DWV Photography & BDWWC members

A few hints From the Internet: Drilling Centered Holes in Dowels

Drilling a hole is usually a simple task. But when it comes to drilling a centered hole in the end of a round workpiece, it's easy to be just a hair off.

So I came up with this easy technique to center the holes perfectly, as in the photo. Start by clamping a scrap to the table of the drill press, as shown in Fig. 1. Then drill a counterbored hole to match the diameter of the dowel (mine were 3/4"-dia.).

This way, when you slip the dowel into the counterbore, it's perfectly centered under the tip of the drill bit. After installing a smaller drill bit, it's a simple matter to drill a hole through the dowel, as you can see in Fig. 2.

Note: To keep the dowel from spinning, clamp a handscrew around it to hold it in place.

Have a nice weekend,

Phillip Huber
Online Editor, *ShopNotes*

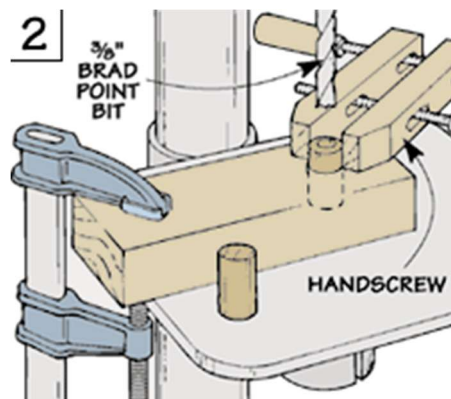
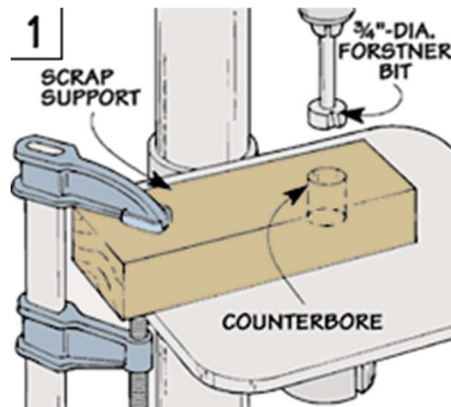

Masking tape saves the day

Glue spots are cruel. When you think all the tedious sanding is done and you apply stain or even varnish, they'll appear like bleached smudges - getting rid of them means more sanding. On a flat surface, glue drips aren't a big deal. You'll remove them automatically as you run through the normal sanding process. But in hard-to-sand spots like inside corners, prevention is the best strategy, and a little masking tape will save you a lot of hassle.

Preventing Splintering:

This woodworking tip involves cutting timber either with a hand saw or drop saw although you are most likely to encounter this problem with a drop saw. There are timbers that are more prone to splintering such as Meranti and cutting it with tools such as a drop saw may cause the edge to splinter. An easy way to prevent this from happening is by putting masking tape along the area that will be cut and this will help to prevent the wood fibres from splintering.

Another way to prevent splintering is to cut along a marked out line first with a marking knife. This should slice the top fibres creating a straight cut.

Easy Odd Width Measuring:

How do you divide 11-3/8-in. (or any other mathematically difficult number) into equal parts without dividing fractions? Simple. Angle your measuring tape across the workpiece until it reads an easily-divisible dimension and make your marks with the tape angled. For example, say you want to divide an 11-3/8-in. board into three equal parts. Angle the tape until it reads 12-in., and then make marks at "4" and "8".

Editor's Note from one who is mathematically challenged. I solve the problem using a strip of paper the length of the space to be divided, then folding it equally into thirds, quarters, or whatever is required. I then mark the work, with a pencil, at each fold line. Works for me.

Stretchy Clamps

Old bicycle inner tubes work great for clamping odd-shaped projects. I used them recently to hold the rungs secure in a set of chairs I glued up. Just knot the tube to the right size and then stretch it over. Set the chair on a flat surface as the glue dries. The tubes can handle jobs that conventional clamps just can't.

— Allen J. Muloon



Just a few thoughts before you go:

If you are going to try cross-country skiing, start with a small country.

Women always worry about the things that men forget; men always worry about the things women remember.

If you think that something small can't make a difference, try going to sleep with a mosquito in the room.

A fine is a tax for doing wrong. A tax is a fine for doing well.

The only person who listens to both sides of an argument is the neighbour next door.

Below, an idea for the musically minded, next time you're trying to think of something to make.



WOMAN:

Shampoo for dry and damaged hair.

MAN:

6 in 1 shampoo for hair, face, body, carpet, car and dishes.

That's all for now, with many thanks, once again, to **Carol Goddard** and her patient assistance with proof-reading this newsletter.