



# MERAHI HAMMOCKS, LLC

**4-Door Bronco Tandem Hammock      Installation Guide**

Designed and Manufactured in the Great State of TEXAS!

## PARTS CHECKLIST

Before you begin, confirm that you received all parts listed below. If you are missing anything, contact Randall via email at [hang@merakihammocks.com](mailto:hang@merakihammocks.com).

HAMMOCK COMPONENTS	QTY	NOTES
Hammock Body	2	
Tension Strap	2	
ATTACHMENT POINTS & HARDWARE	QTY	NOTES
Bracket	4	Front and Rear Attachment Points
M8 Bolts; 30mm	8	Pre-assembled on bracket
M8 Blind Nuts (T-Nuts)	4	Pre-assembled on bracket
Rubber Washers	8	Pre-assembled on bracket

## INSTALLATION OVERVIEW

This guide covers four sequential installation steps. Complete these steps in order. Do not attempt the third step until the first two steps have been completed.

### FRONT ATTACHMENT POINTS (Est. Time ~ 6 min.)

Install the hammock brackets to the Bronco's A-pillar frame above the driver's and passenger's windows.

### REAR ATTACHMENT POINTS (Est. Time ~ 6 min.)

Install the hammock brackets to the top side of the Bronco's C-pillars.

### ASSEMBLE THE TANDEM HAMMOCK (Est. Time ~ 6 min.)

### HANG YOUR MERAKI HAMMOCK (Est. Time ~ 2 min.)





Connect the delta rings to the installed hardware.

**Special Note:** Before you begin, lay down the second row of seating, and with the front driver and (front) passenger seats in the forward position move the driver and (front) passenger seats all the way forward.

**Tools Required:** 13mm socket wrench that you will find in your Bronco's tool kit. (hint: Look in the glove box!)

Designed and Manufactured in the Great State of TEXAS!





## FRONT ATTACHMENT POINTS

	<p><b>1 REMOVE ROOF SECTION.</b> Remove the modular roof panel above the front row of seating. Refer to the Bronco owner's manual for guidance.</p>
	<p><b>2 LOCATE MOUNTING HOLES.</b> Identify the two pre-drilled holes in the frame above the driver's side window, and the two pre-drilled holes in the frame above the passenger-side window.</p>
	<p><b>3 INSERT BLIND NUTS.</b> Unthread the two M8 blind nuts (t-nuts) until they are at the ends of both bolts. (The nuts should be attached to the bolts.) Press the nuts through the holes in the frame above the driver's side window until they are inside the frame.</p>
	<p><b>4 ATTACH BRACKET.</b> Lift up on the bracket. The blind nuts (t-nuts) should hold the assembly in place. Apply upward pressure while hand fastening both bolts until the bracket seats flat against the frame. (The rubber washer will be between the bracket and the frame.)</p>
	<p><b>5 FINAL TORQUE.</b> Using a 13mm socket wrench, torque both bolts to 8-10 ft/lbs.</p>

**Note:** You will repeat steps 3, 4 and 5 on the passenger's side.

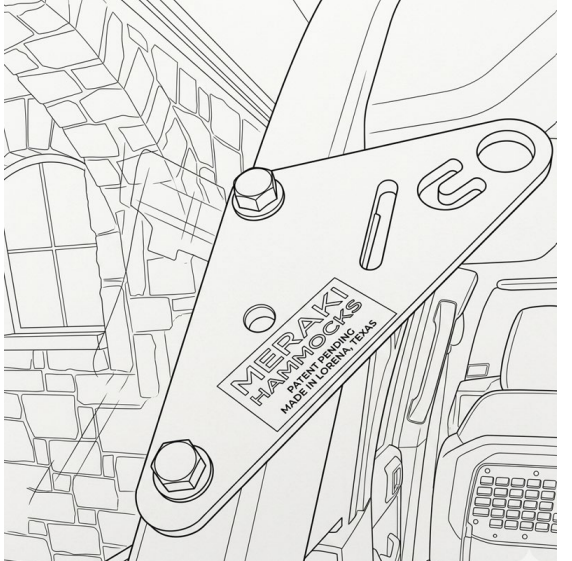
**Warning:** Under-torqued bolts may shift under load. Over-torqued bolts can strip the blind nuts (t-nuts). Use a torque wrench if you have one.

## REAR ATTACHMENT POINT

	<p><b>1 DO NOT REMOVE ROOF.</b> You will be able to install the rear attachment point without removing the roof.</p>
	<p><b>2 LOCATE THE NUT INSERTS.</b> Identify the factory installed nut inserts on the topline of the left C-pillar in the cargo area.</p>
	<p><b>3 ATTACH BRACKET.</b> Starting on the left C-pillar, thread the M-8 bolts into the nut inserts until hand tight.</p>
	<p><b>4 FINAL TORQUE.</b> Using a 13mm socket wrench, torque both bolts to 8-10 ft/lbs.</p>

**Note:** You will repeat steps 2, 3 and 4 on the right C-pillar with the second bracket.

Designed and Manufactured in the Great State of TEXAS!

## ASSEMBLE THE TANDEM HAMMOCK

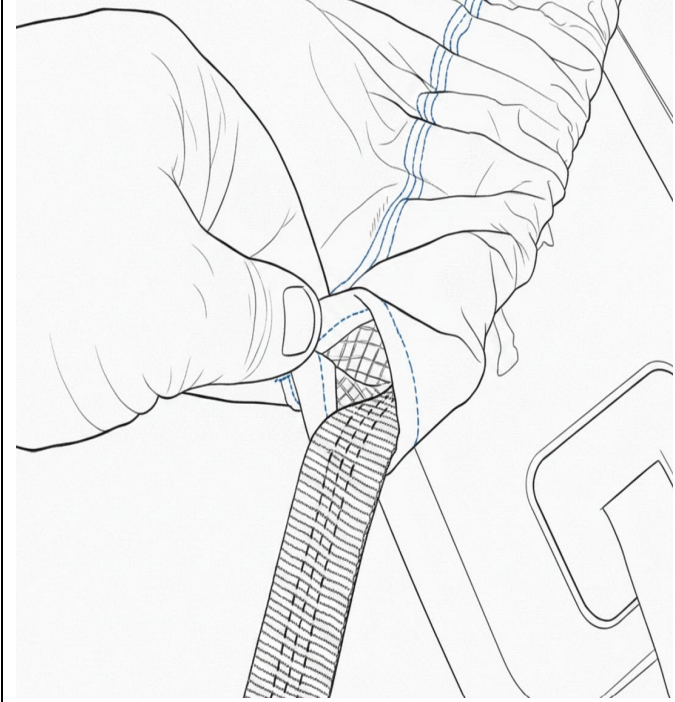
	<b>1 UNFOLD BOTH HAMMOCKS.</b> The tandem hammocks will arrive folded. Unfold both hammocks, and place them side by side, on a clean surface. Locate the channels at both ends, and face the seam side down.
	<b>2 UNCOIL THE TENSION STRAPS.</b> The tandem straps will arrive coiled. Uncoil the tension straps and lay one at each end on top of the channels. The sewn loop should be on the left and the cam buckle should be on the right.
	<b>3 THREAD THE TENSION STRAPS THROUGH EACH CHANNEL.</b> Hold one of the tension straps by the looped end. Hold the hammock on the right with your left hand at the entrance to the channel on the right side of the hammock. Push the looped end of the tension strap through the channel. (The cam buckle can serve as a stopper for the channel to avoid threading the entire tension strap through the channel.) Repeat this with the hammock on the left. When this step is complete, the tension strap will be threaded through one channel on both hammocks.

**Note:** You will repeat step 3 with the second tension strap at the other end of both hammocks.

## HANG THE HAMMOCK – ATTACH FRONT TENSION STRAP TO FRONT BRACKETS

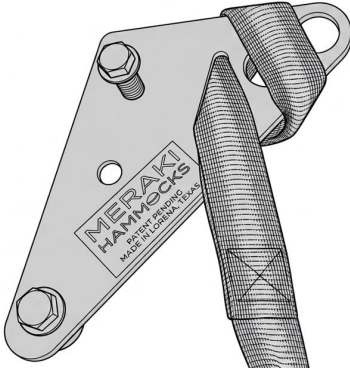
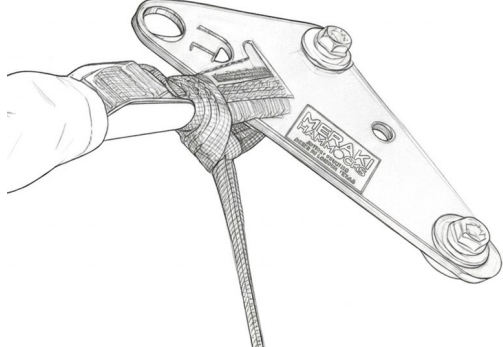
	<p><b>1 LOCATE THE SLOT.</b> Starting with the front bracket on the driver's side, locate the slot in the bracket that runs parallel to the frame. (Repeat this with the front bracket on the passenger's side.)</p>
	<p><b>2 SECURE LOOP ON TENSION STRAP TO BRACKET.</b> Take the looped end of the tension strap and pass that end downward through the slot in the front bracket on the driver's side. Then, pull the loop up and back over the end of the bracket. Pull the tension strap taught. This will lock the looped end onto the front bracket on the driver's side.</p>
	<p><b>3 FINISH SECURING THE TENSION STRAP.</b> Take the other end of the tension strap and pass it up through the slot in the front bracket on the passenger's side. Open the cam buckle by pressing down on the lever. Pass the end of the tension strap through the cam buckle. Pull the tension strap until tight. Secure the excess strap by pushing it down through the slot in the bracket and tying it in an overhand knot over the tension strap.</p>

**Note:** Failure to fully tighten the tension strap will result in a loose hammock.

## HANG THE HAMMOCK – ATTACH REAR TENSION STRAP TO REAR BRACKETS

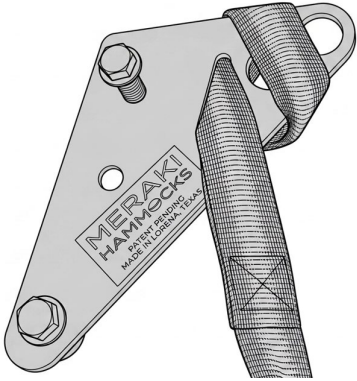
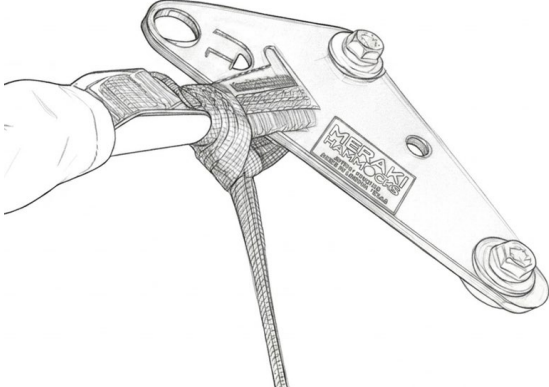
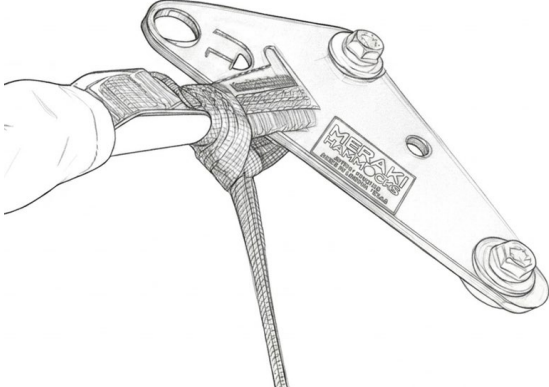
	<p><b>1 LOCATE THE SLOT.</b> Starting with the rear bracket on the driver's side, locate the slot in the bracket that runs parallel to the frame. (Repeat this with the rear bracket on the passenger's side.)</p>
	<p><b>2 SECURE LOOP ON TENSION STRAP TO BRACKET.</b> Take the looped end of the tension strap and pass that end downward through the slot in the rear bracket on the driver's side. Then, pull the loop up and back over the end of the bracket. Pull the tension strap taught. This will lock the looped end onto the rear bracket on the driver's side.</p>
	<p><b>3 FINISH SECURING THE TENSION STRAP.</b> Take the other end of the tension strap and pass it up through the slot in the rear bracket on the passenger's side. Open the cam buckle by pressing down on the lever. Pass the end of the tension strap through the cam buckle. Pull the tension strap until tight. Secure the excess strap by pushing it down through the slot in the bracket and tying it in an overhand knot over the tension strap.</p>

**Note:** Failure to fully tighten the tension strap will result in a loose hammock.

## FINAL SAFETY CHECK

Complete every step below prior to using your Meraki Hammock. This checklist should be re-verified each time your Meraki Hammock is set-up after being stored and after off-road use.

### FRONT ATTACHMENT POINTS

- All M8 bolts are properly torqued to 8-10 ft/lbs; use a torque wrench if available.
- Hammock brackets sits flush against the frame; the rubber washer between the brackets and the frame.
- No visible cracks or deformation in the brackets.

### REAR ATTACHMENT POINTS

- All M8 bolts are properly torqued to 8-10 ft/lbs; use a torque wrench if available.
- Hammock brackets sits flush against the frame; the rubber washer between the brackets and the frame.
- No visible cracks or deformation in the brackets.

### TENSION STRAPS

- Both tension straps are fully tightened.

**Note:** If the tension straps are not tightened the tandem hammock will not function as designed.

### BEFORE EACH USE

- Inspect hammock and tension straps for tears or fraying.

**Warning:** If tears or fraying are present, discontinue use.



If you have questions, email Randall at [hang@merakihammocks.com](mailto:hang@merakihammocks.com).

MERAKEI HAMMOCKS, LLC

LORENA, TX

Not responsible for improper installation or use.

Designed and Manufactured in the Great State of TEXAS!