

- Force sensors and load cells
- Hanging scales
- Sensors for proof load testing
- Water filled bags



FORCE AND WEIGHT MEASURING INSTRUMENTS



Force and weight measuring instruments



From weighing in shipbuilding to measuring anchor and wind forces, measuring and monitoring forces and weights plays a major role in a wide variety of marine engineering applications.

We at Sika supply a wide range of force sensors, load cells, signal amplifiers, accessories, and specialised combination units.

The following pages include a selection of typical instruments that we supply to the marine engineering market.

Our sensors are ideal for measuring maximum forces and weights from 0...10 N / 0...1 kg to 0...5 MN / 0...500 t, with a wide selection of amplifiers giving you excellent flexibility in signal processing from displaying local measurement values to full integration into your vessel's electronics.

We manufacture stainless-steel sensors in hermetically welded, sealed encasements for long service life in harsh conditions. These sensors are available with sea water-resistant, halogen-free cables specifically for marine and offshore applications.

Other features include wireless load cells and force sensors for applications with constantly changing installation points, or where laying cables is not possible.

We also supply sensors with integrated amplifiers on request, such as for applications requiring a standard signal of 4...20 mA; apart from that, we also supply service cases with battery-operated amplifiers for mobile applications.



Please see our general catalogue 'Mechanical Measurement Instruments' for further information about our entire product range force and weight measuring instruments.



Force sensors and load cells

High quality transducers for marine applications

There is virtually no limit when it comes to possible applications for SIKA force sensors and load cells. SIKA offers sensors for compressive and / or tensile loads, special mechanical designs for measuring large steel wire rope forces and offers a wide range of mechanical accessories needed for system integration.

For further information please see our general catalogue 'Mechanical Measuring Instruments' or send us your technical specification. We will be happy to assist you in finding the right solution.

- Solutions for measuring ranges from 0...10 N / 0...1 kg up to 0...5 MN / 0...500 t
- Sensors fully made from stainless steel
- Hermetically sealed by Laser welding, IP67 / 68 rating
- Special cables material on request (salt water and / or oil resistant, halogen free, etc.)
- Force sensors and load cells with integrated amplifier
- Wireless Modular available for many sensors (wireless data transmission)

Force sensors and load cells with full range of mechanical accessoires



Force sensors



Load cells



Hanging scales



Set for proof load testing



Hanging scales

FGR5A

The FGR5A is designed to take tensile load measurements in situations that call for direct indication of measured values and straightforward connection to the measuring device.

The unit consists of a load cell, which offers particularly good long-term stability, combined with a compact display device. This display device consists of a digital measurement amplifier with an integrated digital display and bar graph. The metal housing provides the requisite sturdiness and protects the device from outside influences.

The shackle allows the FGR5A to be quickly integrated into and removed from the application. The four replaceable standard batteries provide an operating time of around one year.

Energy management in the device is optimised by an automatic shut-off function, which is triggered when the unit is not in use. Excessive loads are clearly indicated by an acoustic warning signal.

Performance features

- Supplied with remote control and transport case
- High accuracy and long-term stability
- Robust and compact design
- Quick and easy installation and removal
- Zero and hold function

Optionen

- Serial interface RS-232C



Technical data

Hanging scales FGR5A					
Nominal load (E_{max})	500 kg	1 t	3 t	6.5 t	9.5 t
Load transfer direction	Tension				
Accuracy	$< \pm 0,05 \% E_{Max}$				
Sampling rate	1 Hz				
Resolution	0.1 kg	0.2 kg	0.5 kg	1 kg	2 kg
Save load limit	150 % full scale				
Security coefficient	> 5				
Degree of protection EN 60529	IP20				
Supply voltage					
Operating voltage	4 x 1.5 V, Size AA				
Weight					
Overall	3.5 kg		7.5 kg		12 kg

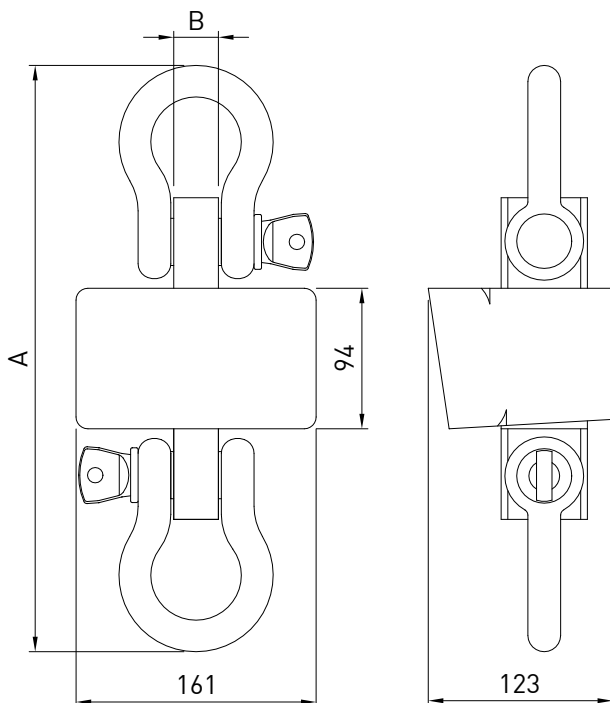

Nominal load	A	B	C	ØD	E
500 kg - 1 t	270	16	178	16	57
3 t - 6.5 t	400	30	213	25	57
9.5 t	477	40	239	32	70

Wireless force and weight measuring system

F5000MW and FT24-HS for proof load testing

Inspecting cranes with weights, particularly on derricks, is one of the most important safety-relevant tests that need to be performed during maintenance. During these tests appropriate load cells are of fundamental importance to ensure a smooth process.

For many years, SIKA has been supplying a load cell system that is precisely tailored to this application. We have now managed to improve our solution for proof load testing even further. With the new F5000MW load cell in-shackle design we have achieved simpler connection to the crane. With this load cell we can measure loads of up to 200 t. But the most important attribute of all is that the F5000MW and the FT24-HS display unit now has a wireless solution to check derricks which is ingress protected, making it suitable for harsh environments.

Performance features

- Nominal loads of 1t to 200 t are available
- Simple installation with in-shackle design
- Degree of protection IP65
- Wireless range up to 500 m
- Wireless FT24-HS display unit

Options

- Version with external antenna (up to 800 m range)



Technical data

Hanging scale F5000MW	
Nominal load (E_{max})	1 / 2,5 / 4 / 5 / 6,3 / 8 / 12 / 20 / 30 / 45 / 75 / 80 / 115 / 150 / 200 t (higher on request)
Load transfer direction	Tension
Rated characteristic value (C_{nom})	1 mV/V
Material	Stainless steel (bolt) / Steel (shackle)
Degree of protection EN 60529	IP65
Encapsulation	Hermetically sealed by welding
Range	500 m open field
Own weight	3...585 kg
Error limits	
Linearity	< 0.250 % E _{Max}
Creep (over 30 min)	< 0.300 % of E _{max}
Temperature effect on zero signal per 10 °C	< 0.200 % of E _{max}
Temperature effect on characteristic value per 10 °C	< 0.200 % of E _{max}
Maximum load	
Safe load limit (E _{lim})	150 % of E _{max}
Breaking load	> 500 % of E _{max}
Lateral load limit	150 % of E _{max}
Temperature data	
Reference temperature	23 °C
Nominal temperature range (B _{nom})	-10...45 °C
Operating temperature range	-30...70 °C

Wireless Display FT24-HS	
Display	7 digits LCD of 8.8 mm high
Power supply	2.5...3.6 VDC
Service temperature range	-10...50 °C
Storage temperature range	-40...85 °C
Degree of protection EN 60529	IP67
Dimensions	152 x 90 x 34 mm

Dimensions

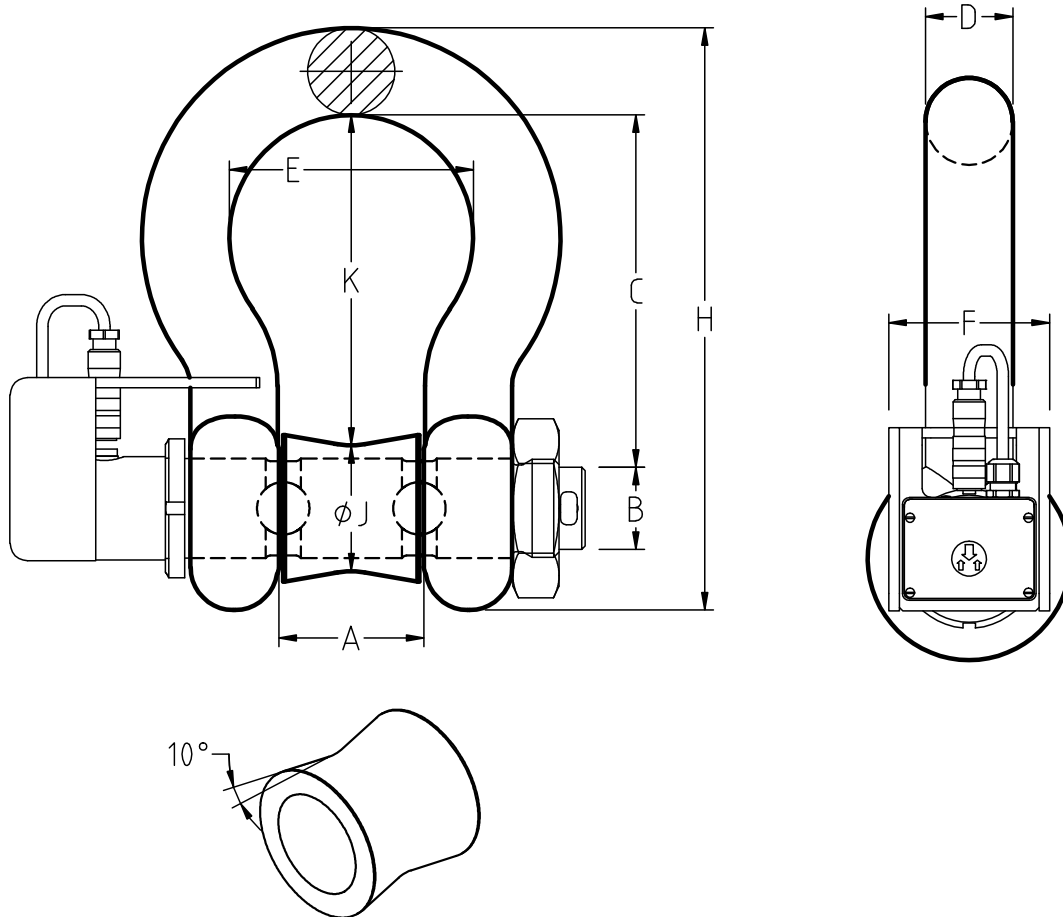

Load	Dimensions [mm]									Tolerances ± [mm]		
	A	B	C	D	E	F	H	ØJ	K	C / K	A	
1 - 1.5 t	31	22	75	19	51	46	126	34	65	6.5	1.6	
2.5 t	36	25	84	22	58	53	148	35.5	79			
4 t	43	28	95	25	68	60.5	167	37	90			
5 t	46	32	108	28	74	68.5	190	40	104		3.5	
6.3 t	57	38	133	35	92	85	233	50	127			
8 t	60	42	146	38	99	92	254	54	140			
12 t	73	50	178	45	127	106	313	65	171		6.5	
20 t	83	57	197	50	138	122	348	72	189			
30 t	105	70	264	65	180	145	453	90	250			
45 t	127	80	330	75	190	165	546	105	319		/	/
75 t	147	95	400	95	238	203	647	117	389			
80 t	140	108	368	104	254	229	653	130	357			
115 t	200	140	540	130	305	308	921	165	527	/	/	
150 t	200	150	600	140	305	335	1018	180	585	/	/	
200 t	225	175	650	170	325	387	1137	200	630	/	/	

Sensors for tensile loads

FT20 and FD200

Our heavy-load cells are suitable for measuring large tensile forces. We provide five different versions with nominal loads from 20 to 100 t.

The 60 mm or 73 mm diameter connector bores provide attachment for connector bolts in fork bearings. They may also be used with quality shackles as connectors for measuring large forces on cables. We provide the appropriate shackles as accessories on request.

Performance features

- Measurement ranges available from 20 to 100 t
- Laser-welded for complete insulation
- Easy to integrate into your application
- High long-term measurement stability
- A large number of mechanical mounting aids are available

Options

- Version available with cable-free measurement signal transmission
- Connection cable 5 or 10 m MIL connector
- Equipped with shackles for measuring forces on cables



FT20

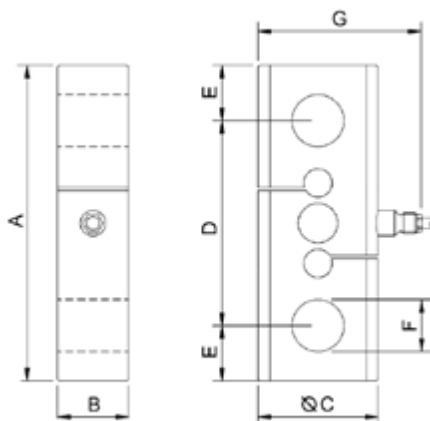

FD200

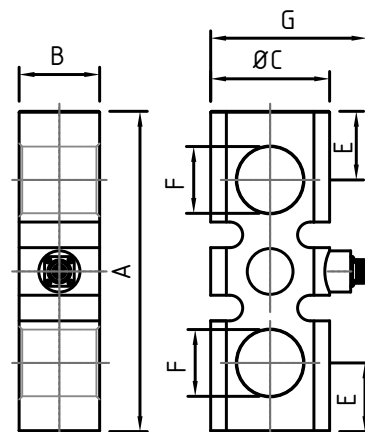

Type	Load	Dimensions [mm]							Part No.**
		A	B	ØC	D	E	F	G	
FT20	5 t / 7.5 t / 10 t	200	45	76	130	35	33*	Approx. 103	FT20000WExxx22C
	15 t / 20 t	250	54	82	156	47	42.5*	Approx. 109	FT20000WExxx22C
FD200	20 t / 30 t	280	78	102	-	50	60	Approx. 140	FD20000WExxx26
	50 t / 75 t / 100 t	350	88	130	-	75	73	Approx. 171	FT20000WExxx26

* Connection holes for standard shackles

** xxx = maximum capacity [5t = 005, 7.5 t = 7.5, 10 t = 010, 50 t = 050]

Technical data

Heavy-load cell		FT20	FD200
Maximum capacity	(E _{max})	5 / 7.5 / 10 / 15 / 20 t	20 / 30 t
Load transfer direction		Tension	
Rated characteristic value	(C _{nom})	2 mV/V	
Material		Stainless steel	
Degree of protection EN 60529		IP68	IP65 (with connector), IP67 (with cable)
Encapsulation		Hermetically sealed by welding	
Own weight		4.4 kg	7 kg
Connection		10 m cable	MIL-C-5015 7-pin connector / cable
Error limits			
Combined error		< 0.023 % of E _{max}	< 0.100 % of E _{max}
Linearity		-	< 0.100 % of E _{max}
Hysteresis		-	< 0.100 % of E _{max}
Non-repeatability		< 0.014 % of E _{max}	-
Zero Return over 30 min. at nominal load:		< 0.030 % of E _{max}	-
Creep (over 30 min).		< 0.024 % of E _{max}	-
Creep (over 20 and 30 min).		< 0.011 % of E _{max}	-
Temperature influence zero signal for each 10 °C		< 0.028 % of E _{max}	< 0.028 % of E _{max}
Temperature effect on characteristic value per 10 °C		< 0.008 % of E _{max}	< 0.008 % of E _{max}
Electrical data			
Input resistance		420 ± 20 Ω	
Output resistance		350 ± 2 Ω	
Insulation resistance		> 5 GΩ	
Supply voltage		1...15 V (typically 10 V)	
Operating voltage		1...18 V	
Maximum load			
Operating load		120 % of E _{max}	120 % of E _{max}
Load limit	(E _{lim})	150 % of E _{max}	150 % of E _{max}
Breaking load		> 300 % of E _{max}	> 200 % of E _{max}
Lateral load limit		200 % of E _{max}	50 % of E _{max}
Temperature data			
Reference temperature		23 °C	
Nominal temperature range		-10...40 °C	
Operating temperature range		-20...70 °C	

Shackles as an accessory to FT20 and FD200

Type	Load	Working Load Limit (WLL)*	Part No.
for FT20	5 t / 7.5 t / 10 t	9.5 t	FG-4161ZX0035
	15 t / 20 t	17 t	FG-4161ZX0017
for FD200	20 t / 30 t	35 t	FG-4161ZX0035
	50 t / 75 t / 100 t	55 t	FG-4161ZX0055

* Minimum breaking load = 6-times WLL

FPMA

Developed specifically for demanding applications, the professional FPMA compact display unit combines the advantages of a mobile measurement amplifier with the technical properties of a stationary device and a datalogger.

FPMA units feature a stable aluminium housing and are ideal for the use with our FT20 or FD200 load cells. The standard FPMA is connected to the sensor via cable. As an option, this compact display unit is available with Wireless Modular technology. This allows the FPMA to be used with SIKA sensors equipped with wireless data transmission module.

Up to 4800 measurement values per second can be read with a resolution of $\pm 50\,000$ steps. This also makes the FPMA interesting for dynamic and highly-precise applications.

To round off the wide functional scope, additional functions such as a datalogger with memory for 130,000 measurement values, filtering functions, detection of measurement value peaks and the preventative blocking of measurement values are available.

A USB connection is provided as standard on all units, which permits both real-time communication with the PC and charging the integrated Li-ion rechargeable battery.

Performance features

- Compact unit in an ergonomic, convenient format
- Large, illuminated and rotatable LCD display
- Battery-powered
- DMS input 2 mV / V
- 1 sensor connectible
- 4-wire connection type
- Accuracy < 0.010 %
- Datalogger integrated
- Automatic sensor detection
- USB interface

Type FPMA



Options

- Integrated force sensor from 10 N to 5 kN
- Version available with wireless measurement signal transmission

Technical data

Compact display unit		FPMA
Accuracy		< 0.010 %
Resolution (2 mV / V)		±50 000 steps
Sampling rate		5...4800 Hz
Strain gauge input		2 mV/V
Number of sensors that can be connected		1 (350 Ω or 700 Ω)
Supply voltage		5 V DC ±4%
Connection type		4-wire
Degree of protection EN 60529		IP40
Supply voltage		
Operating voltage		Internal lithium ion battery
Automatic shutoff		1...99 min
Digital display		
LCD display		128 x 64 pixel, illuminated, rotatable
Temperature data		
Nominal temperature range		0...50 °C
Temperature deviation (10 °C)		
→ Measuring range zero point		< 0.010 %
→ Measuring range full scale value		< 0.010 %
Dimensions		
Overall		79 x 176 x 32 mm (L x W x H);

Water filled bags

For proof load testing

Water weights are a unique, safe and simple product specifically designed to provide a test load instead of traditional solid test weights. They are used for proof load testing of cranes and lifting devices.

- Water bags are certified in accordance with health and safety executive requirements
- Water bags weigh less than 2 % of achievable load allowing for considerable savings in transport, storage and labour costs.
- The bags have a physically proven factor of safety in excess of 6:1 and are proof load tested to over 2:1 prior to be taken into service.

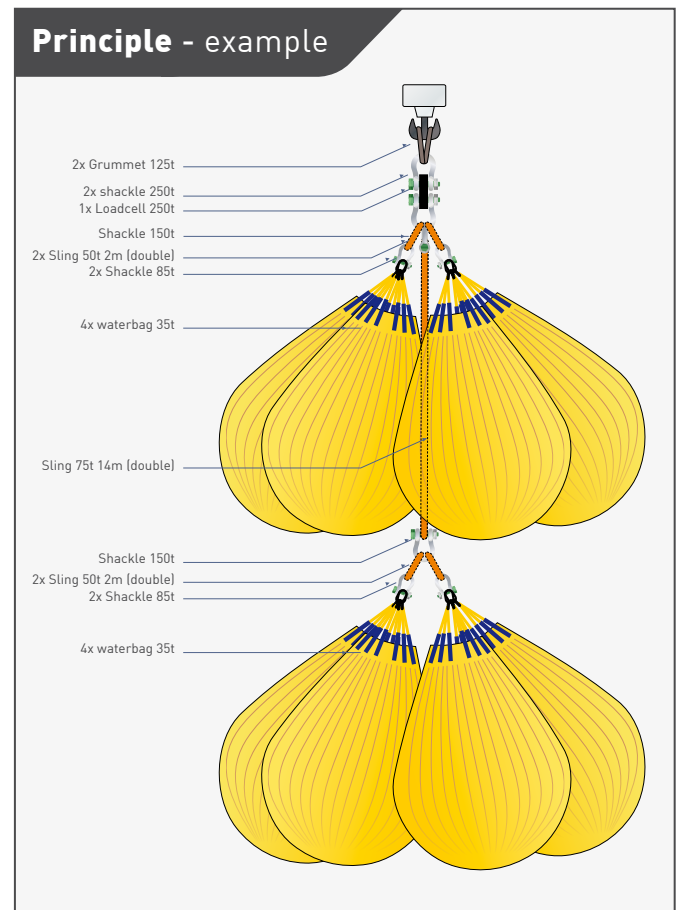

Note: no more than three bags should be slung from a single point. Dimensions are subject to change. Bags filled with less than their capacity will increase in length and reduce in diameter. Bags should not be used in wind speed greater than 25 knots.

Dimensions and order code

Capacity Tonnes	Capacity - L	Size - empty and rolled in m	Weight in kilos	Size when full - height in m	Size when full diam in m	Part No.
1	1000	0.9 x 0.56 x 0.56	23	2.3	1.2	FWFBVFRZY0001
2	2000	1 x 0.6 x 0.6	45	3.5	1.6	FWFBVFRZY0002
2L	2000	1 x 0.6 x 0.6	40	2.1	1.9	FWFBVFRZY0002L
5	5000	1.07 x 0.7 x 0.7	100	4.6	2.0	FWFBVFRZY0005
5L	5000	1.07 x 0.7 x 0.7	95	2.5	2.7	FWFBVFRZY0005L
10	10000	1.1 x 0.8 x 0.8	135	5.8	2.5	FWFBVFRZY0010
12L	12000	1.2 x 0.8 x 0.8	140	4.0	3.0	FWFBVFRZY0012L
12.5L	12500	1.2 x 0.8 x 0.8	140	4.25	3.22	FWFBVFRZY12X5L
20	20000	1.1 x 1 x 1	230	5.8	3.5	FWFBVFRZY0020
35	35000	1.7 x 1.2 x 1.2	340	7.0	4.2	FWFBVFRZY0035

