

- Electronic digital thermometer
- Multi-channel temperature indicator
- Temperature sensors
- KombiTemp®



ELECTRONIC MONITORING SYSTEMS
AND TEMPERATURE SENSORS



Electronic digital thermometer

SolarTemp type 850 with mounting plate

- Display suitable for sensor elements Pt1000
- Degree of protection IP65
- Measuring range 0...650 °C
- Optional Transmitter output 4...20mA
- Selection of temperature sensors for SolarTemp Type 850 is located on page 56

Technical data	
Ambient temperature	-20...60 °C (case)
Case	170 x 150 mm, steel case blue powder-coated, aluminium mounting plate
Power supply	Solar cell
Light density	Min. 50 Lux
Digital display	4 digit, 7 segment display, 25.4 mm high

Approved by several classification societies

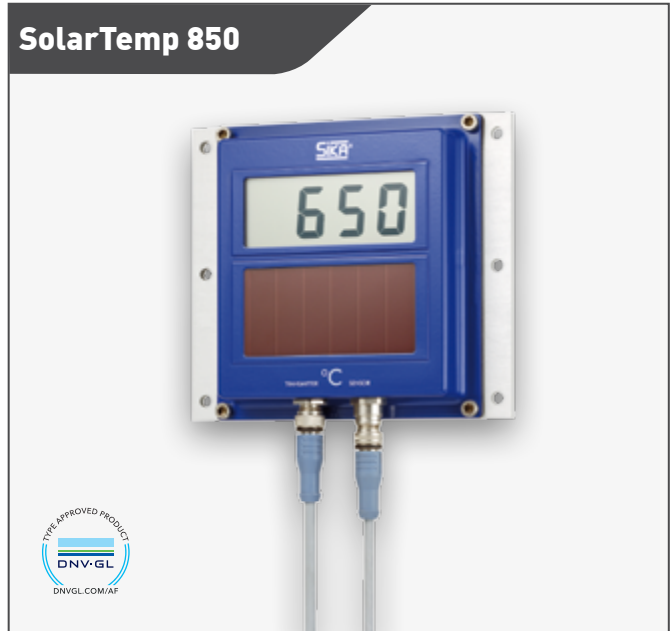

Order code				
Type	Range	SIKA-Code	ISSA-Code	IMPA-Code
Standard version	0...650 °C	85065P54	61 122 51	651861
Transmitter version	4...20 mA 0...600 °C	85065P53360	61 122 52	651862
Transmitter version	4...20 mA 0...300 °C	85065P53330	61 122 53	651863

SolarTemp applications



SolarTemp type approval certificates

- DNV GL type approval
- ABS
- ClassNK Nippon
- LR
- BV
- Korean R.

Temperature sensors

Temperature sensors for marine applications

Temperature measurement in marine applications makes high demands on sensor reliability. Standard temperature sensors not specifically designed for this application will not last long time in this environment. Especially sensors used on diesel engines and propulsion systems are subject to severe vibration with acceleration as high as 200 g in some cases as well as occasional exposure to water and oil. SIKA has longterm experience in manufacturing products for the marine industry and together with engine builders and end users has developed a wide range of temperature sensors suitable for this harsh environment.

Rugged design, vibration resistant components and reliable manufacturing give SIKA sensors a long lifetime also under difficult conditions. For quality assurance each sensor is thoroughly tested during and after production. The quality management system installed by SIKA guarantees a constant and reliable performance of the products.

Due to the high flexibility of SIKA, sensors in many common designs are available. Special sensors can be manufactured on request.

Important calibration instructions

Temperature sensors may be subject to changes in accuracy during their lifetime. A periodic calibration of your temperature sensors is required to make sure that they display always a correct temperature value. We provide you with the relevant calibration tools. Please see selection of Test & Calibration products from page 85.

SIKA temperature sensors

- For exhaust gas temperature measurement
- For cooling water temperature measurement
- For oil temperature measurement

Approvals

- Most sensors are approved by Germanischer Lloyd
- Additional approvals on request

Temperature sensors approval certificates

- DNV GL type approval
- ABS
- ClassNK Nippon
- BV
- RINA



Temperature sensor and sensor cable

for SolarTemp type 850

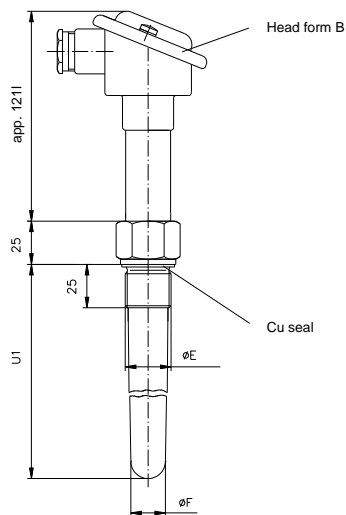

Fig. A

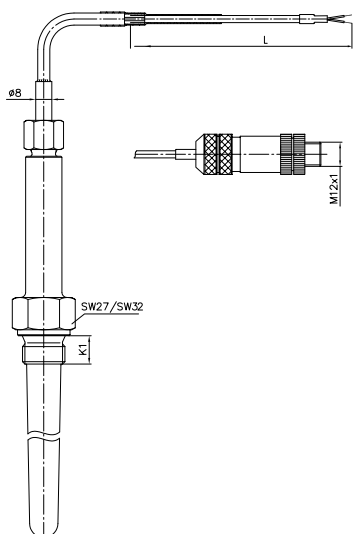

Fig. B

Please ask for customised specifications



Order code	SIKA-Code	ISSA-Code	IMPA-Code
Sensor cable (connection sensor to indicator)			
Length*			
3 m	XPV108	61.122.72	651866
5 m	XPV109	61.122.73	651867
10 m	XPV110	61.122.74	651868
15 m	XPV158	61.122.75	651869
Transmitter cable (connection indicator to remote control)			
10 m	XPV150		651871
15 m	XPV167		651872

* Other lengths available on request

Order example	W	14	3	P53	100	2	3	8	2	03	ISSA-Code	IMPA-Code
Type												
Resistance thermometer	W											
Diameter												
14 / 17 mm conical (U1 = 100 mm or 150 mm)		14										
17 / 23 mm conical (U1 = 100 mm or 150 mm)			17									
20 / 23 mm conical (U1 = 200 mm)			20									
Material												
Stainless steel 1.4571			3									
Sensor element												
2 x Pt1000 (only for transmitter version)				P53								
1 x Pt1000				P54								
Immersion tube length U1												
100 mm					100						61.122.55	
150 mm					150						-	651865
200 mm					200						61.122.76	
Measuring insert												
Demountable						2						
Electrical connection												
Plug M12 x 1 (Fig. B)							3					
Head form B (Fig. A)							B					
Cable												
Teflon FEP shielded (only plug M12 x 1) (Fig. B)								8				
Without cable (only Head B) (Fig. A)								0				
Process connection												
G½									2			
G¾									3			
Thread M33 x 2									F			
Cable length (only Fig. B)												
2.0 m										03		
3.0 m										05		
5.0 m										09		



For exhaust gas temperature measurement

Type W20

Temperature sensor with connection head form B. This robust sensor is used for measuring exhaust gas temperatures. It is used in large diesel engines such as those on ships and in combined heat and power stations. It is also used in turbines and compressors.

Technical features

- Very high vibration resistance
- One-piece protection tube
- Available with optional instrument transformer
- Customer-specific fitting lengths and fixing thread on request

Accuracy class

- Resistance thermometer class B
- Thermocouple class 1

Measuring insert

Interchangeable

Diameter

- 14 / 17 mm conical up to 150 mm
- 17 / 23 mm conical up to 150 mm
- 20 / 23 mm conical from 200 mm

Degree of protection

IP54

Max. Temperature

Depending on Immersion tube material

Process connection

Fix connecting thread

Electrical connection

Head form B made of aluminium diecasting, silver finish, max. temperature 200 °C

Approvals

DNV GL type approval

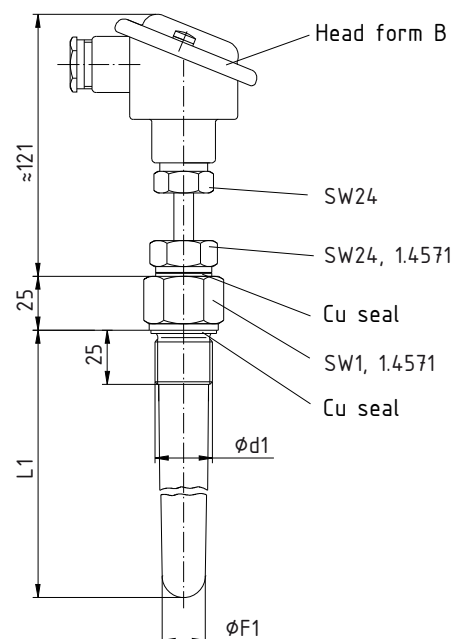

Order code

Order example	W	20	3	P31	100	2	B0	3T6	ISSA-Code	IMPA-Code
Type										
Resistance thermometer	W									
Thermocouple	T									
Diameter										
14 / 17 mm conical (U1 = up to 150 mm)		14								
17 / 23 mm conical (U1 = up to 150 mm)		17								
20 / 23 mm conical (U1 = 200 mm up to 300 mm)		20								
Material										
Stainless steel 1.4571 (max. 450 °C)			3							
Steel 1.7335 (max. 600 °C)			5							
Sensor element										
1 x Pt100 3-wire / class B				P31						
1 x Pt1000 2-wire / class B				P12						
1 x Fe-CuNi (Typ J)				1TJ					61.116.00	
2 x Fe-CuNi (Typ J)				2TJ					-	65 25 22
1 x NiCr-Ni (Typ K)				1TK					61.116.12	
2 x NiCr-Ni (Typ K)				2TK						
Resistance thermometer / class A				AXX						
Length U1*										
100 mm					100					
120 mm					120					
150 mm					150					
200 mm					200					
250 mm					250					
300 mm					300					
Measuring insert										
Interchangeable						2				
Electrical connection										
Head form B with ceramic socket							B0			
Hopf form B with transmitter							BT			
Process connection d₁*										
G½ A (Ø 14 / 17 mm)								2T6		
G¾								3T6		
M27 x 2								HT6		
M33 x 2								FT6		

* Other specifications are also available on request

Type T55

Temperature sensor with connecting cable and Cannon connector. This robust sensor is designed for measuring exhaust gas temperatures. It is used in diesel engines such as those on ships and in combined heat and power stations. It is also used in turbines and compressors.

Thanks to the flexible light plastic-sheathed cable, even measurement points that are difficult to access can be reached. It is also extremely resistant to external temperature influences.

Technical features

- Reliable electrical connection thanks to robust Cannon connector system
- High vibration resistance
- Optional protection tube available
- Customer-specific fitting lengths and fixing thread on request

Accuracy class

Thermocouple class 2

Measuring insert

Not interchangeable

Diameter

5.2 mm

Degree of protection

IP54

Max. temperature

800 °C for thermocouple

Process connection

Without or with clamp coupling

Electrical connection

Mineral insulated cable with Cannon plug

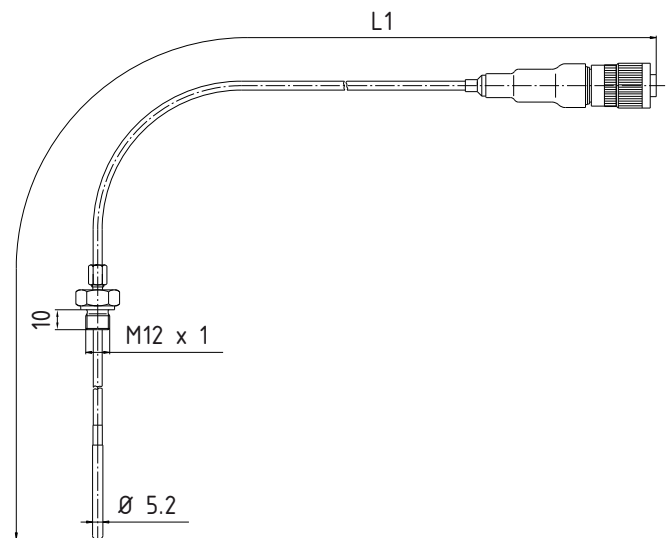

Order code

Order example	T55	3	1TK	1500	X0	R	ISSA-Code	IMPA-Code
Diameter								
5.2 mm	T55							
Material								
Stainless steel 1.4571		3						
Sensor element								
1 x NiCr-Ni (type K)			1TK				61.116.21	
2 x NiCr-Ni (type K)			2TK				-	652527
Length L*							61.116.38	
1500 mm				1500				
Electrical connection								
Mineral insulated cable with Cannon plug					X0			
Process connection								
Clamp coupling steel, M12 x 1						R		

* All other lengths are also available on request

Type T45

Temperature sensor with connecting cable. This robust sensor is designed for measuring exhaust gas temperatures. It is used in large diesel engines such as those used on ships and in combined heat and power stations. It is also used in turbines and compressors.

Technical features

- Very high vibration resistance
- Exceptionally durable connecting cable
- Customer-specific fitting lengths on request

Accuracy class

Thermocouple class 1

Measuring insert

Interchangeable

Diameter

4.5 mm

Degree of protection

IP54

Max. temperature

800 °C for thermocouple

Process connection

Fitting

Electrical connection

Cable, wire-braided

Approvals

DNV GL type approval

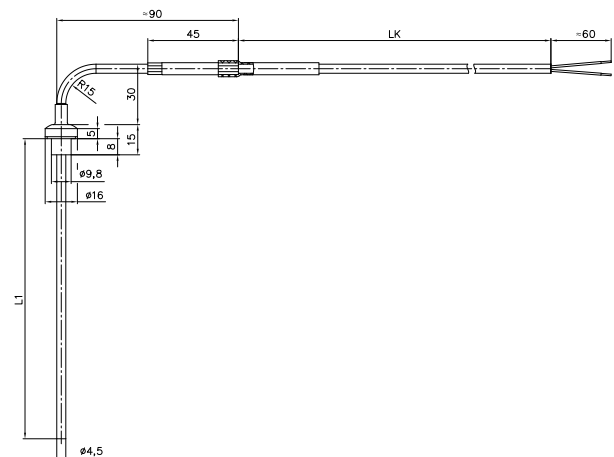

Order code

Order example	T	45	3	1TK	045	07	01	01
Type								
Thermocouple	T							
Diameter								
4.5 mm		45						
Material								
Stainless steel 1.4541			3					
Inconel 2.4816			4					
Sensor element								
1 x NiCr-Ni (type K)				1TK				
2 x NiCr-Ni (type K)				2TK				
Length L1*								
45 mm					045			
80 mm					080			
104 mm					104			
138 mm					138			
150 mm					150			
Electrical connection								
FEP cable, wire-braided						07		
Process connection*								
Fitting SW5, 3-4 mm, stainless steel 1.4571							01	
Cable length LK								
1.0 m								01
1.5 m								02
2.0 m								03
2.5 m								04

* Other specifications available on request

Type T95

Temperature sensor with connecting cable. This robust sensor is designed for measuring exhaust gas temperatures. It is used in diesel engines such as those on ships and in combined heat and power stations. It is also used in turbines and compressors.

Technical features

- High vibration resistance
- Optional protection tube available
- Exceptionally durable connecting cable
- Customer-specific fitting lengths and fixing thread on request

Accuracy class

Thermocouple class 2

Measuring insert

Not demountable

Diameter

9.5 mm

Degree of protection

IP54

Max. temperature

600 °C for thermocouple

Process connection

- Without
- Clamp coupling

Electrical connection

- FEP cable, wire-braided
- Fibre glass, wire-braided

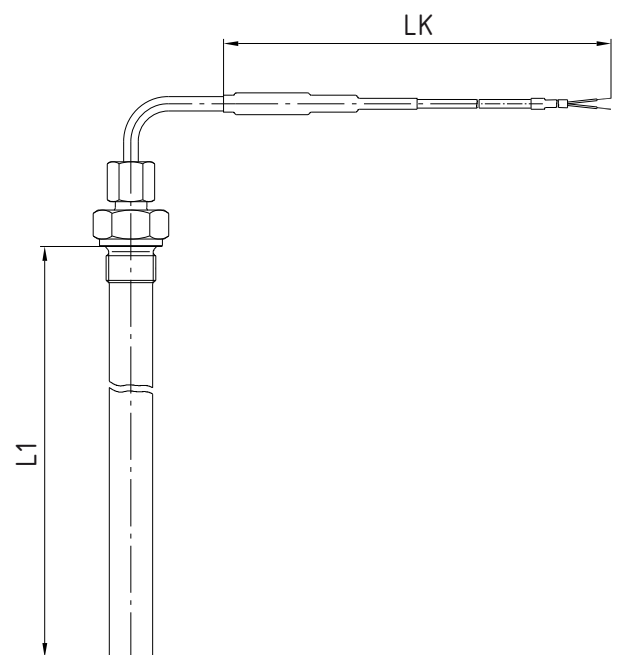

Order code

Order example	T95	3	1TK	1000	07	0	02	ISSA-Code	IMPA-Code
Diameter									
9.5 mm	T95								
Material									
Stainless steel 1.4571		3							
Sensor element									
1 x NiCr-Ni (type K)			1TK						
2 x NiCr-Ni (type K)			2TK						
Length*									
200 mm				2000				61.116.40	
250 mm				2500				-	652527
290 mm				2900				61.116.54	
Electrical connection									
FEP cable, wire-braided					07				
Fibre glass, wire-braided					08				
Process connection									
Without						0			
Adjustable union nut M18 x 1.5						1			
Cable length LK*									
1.5 m							02		
2.5 m							04		
5.0 m							09		

* All other lengths are also available on request

Type T10

Temperature sensor with connecting cable. This robust sensor is designed for measuring exhaust gas temperatures. It is used in diesel engines such as those on ships and in combined heat and power stations. It is also used in turbines and compressors.

Technical features

- Compact design
- Very high vibration resistance
- One-piece protection tube
- Exceptionally durable connecting cable
- Customer-specific fitting lengths and fixing thread on request

Accuracy class

Thermocouple class 1

Measuring insert

Interchangeable

Diameter

Conical 10 mm to 8 mm

Degree of protection

IP54

Max. temperature

850 °C for thermocouple

Process connection

Fix connecting thread

Electrical connection

Cable

Approvals

DNV GL type approval

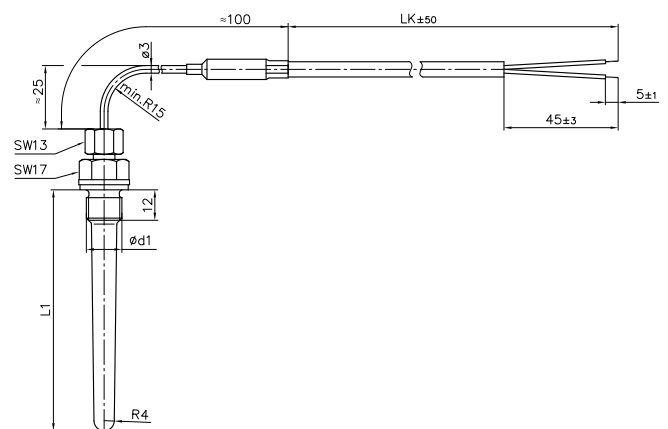

Order code

Order example	T	10	0	1TK	065	2	07	L	01
Type									
Thermocouple	T								
Diameter									
10 mm		10							
Material									
Steel 1.4876			0						
Sensor element									
1 x NiCr-Ni (Type K)				1TK					
Length L1*									
65 mm					065				
95 mm					095				
Measuring insert									
Interchangeable						2			
Electrical connection									
FEP-cable, wire-braided							07		
Process Connection d1*									
M14 x 1.5								G	
G¼ A								L	
Cable length LK*									
1.0 m									01
1.5 m									02
2.0 m									03
2.5 m									04

* Other specifications available on request

Type TWE

Temperature sensor with connecting cable. This robust sensor is designed for measuring exhaust gas temperatures. It is used in diesel engines such as those on ships and in combined heat and power stations. It is also used in turbines and compressors.

Technical features

- High vibration resistance
- Exceptionally durable connecting cable
- Customer-specific fitting lengths and fixing thread on request

Accuracy class

- Resistance thermometer class B
- Thermocouple class 1

Measuring insert

Not interchangeable

Diameter

- 8 mm
- 12 mm

Degree of protection

IP54

Max. Temperature

- 600 °C resistance thermometer
- 800 °C thermocouple

Process connection

- Plain immersion tube
- Clamp coupling

Electrical connection

Compensation pipe, wire-braided

Approvals

DNV GL type approval (only for type TWE)

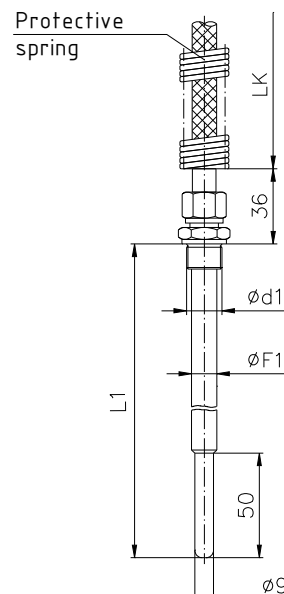

Order code

Order example	TVA	C	K11	0100	07	0	02	ISSA-Code	IMPA-Code
Diameter F1									
8 mm	TVA								
12 mm	TWE								
Material									
Stainless steel 1.4571		C							
Sensor element									
1 x Fe-CuNi (type J)			J11						
1 x NiCr-Ni (type K)			K11						
1 x Pt100 3-wire / class B (type TWE only)			P31						
2 x Pt100 3-wire / class B (type TWE only)			P32						
Length L1*									
100 mm				0100				61.116.55	
150 mm				0150				-	65 25 27
200 mm				0200				61.116.84	
250 mm				0250					
Electrical connection									
FEP cable, wire-braided					07				
Fibre glass, wire-braided					08				
Process connection d1*									
Without						0			
Clamp coupling steel, galvanized G¼						I			
Clamp coupling steel, galvanized G½						K			
Clamp coupling stainless steel G½						J			
Clamp coupling steel, galvanized M27 x 2						H			
Cable length LK*									
1.0 m							01		

* Other specifications are also available on request

For oil- and water temperature measurement

Type W30

Temperature sensor with angle plug as electrical connection. This sensor is designed with compact dimensions and is intended for use in industrial applications for measuring liquid and gaseous media.

Technical features

- High vibration resistance
- Reliable electrical connection using screw-on connectors
- Customer-specific fitting lengths and fixing thread on request

Sensor element

Resistance thermometer class A and B

Measuring insert

Interchangeable only for $\varnothing 8$ mm

Diameter

- 6 mm
- 8 mm

Degree of protection

IP65

Max. Temperature

200 °C Resistance thermometer, max. 125 °C at plug

Process connection

Fix connecting thread

Electrical connection

Cable socket, angle type, DIN EN 175 301-803, form A

Approvals

DNV GL type approval

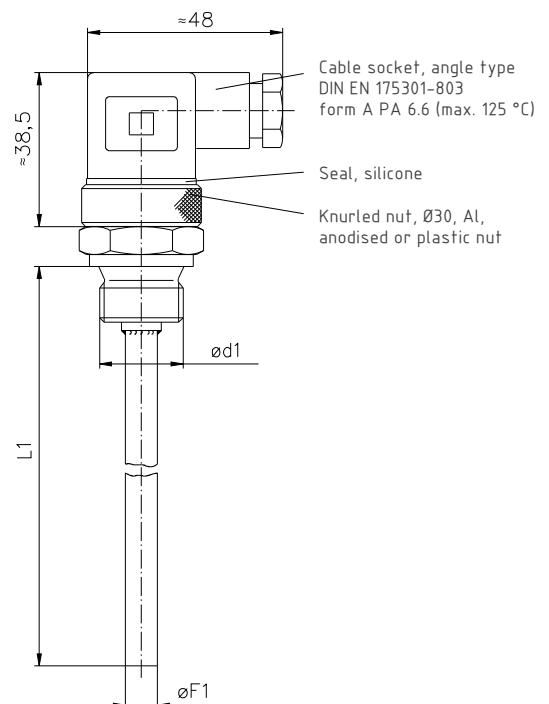

Order example	W	06	1	P21	050	0	10	2	GL
Type									
Resistance thermometer	W								
Measuring insert	E								
Diameter									
6 mm		06							
8 mm		08							
Material									
Brass 2.0401 / 2.0402			1						
Stainless steel 1.4571			3						
Sensor element									
1 x Pt100 2-wire / class B				P21					
1 x Pt100 3-wire / class B				P31					
1 x Pt100 4-wire / class B				P41					
Resistance thermometer / class A				AXX					
Immersion tube length L1*									
Without (only for type measuring insert)					000				
50 mm					050				
100 mm					100				
150 mm					150				
200 mm					200				
Measuring insert									
Not interchangeable						0			
Interchangeable (only for Ø 8 mm)						2			
Electrical connection									
Cable socket, angle type form A							10		
Process connection d1									
G½ A								2	
M18 x 1.5								6	
M20 x 1.5								N	
G¾ A								3	
Options									
Version Germanischer Lloyd									GL

* Other specifications available on request

Type WMJ

Temperature sensor with connection head form J. This robust sensor is designed for use in industrial and marine applications for measuring the temperature of cooling water, lubricants and hydraulic oil.

Technical features

- Very high vibration resistance
- Simple alignment of the connection head
- One-piece protection tube
- Available with optional instrument transformer
- Customer-specific fitting lengths and fixing thread on request

Sensor element

Resistance thermometer class A and B

Measuring insert

Interchangeable

Diameter

8 mm

Degree of protection

IP54

Max. Temperature

200 °C resistance thermometer

Process connection

Fix connecting thread

Electrical connection

Head form B made of aluminium diecasting, silver finish, max. temperature 125 °C

Approvals

DNV GL type approval, ABS, BV, LRS, RINA and Class NK

Type WMJ

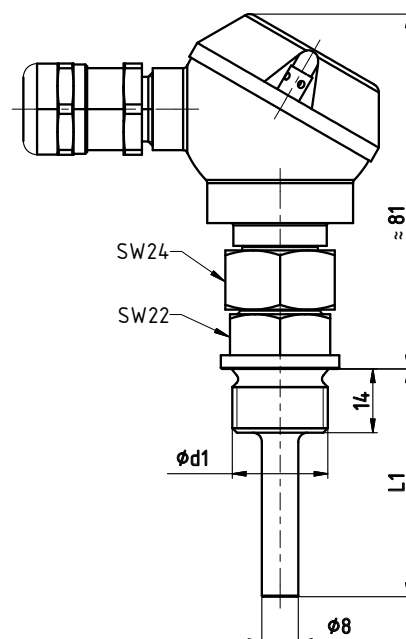
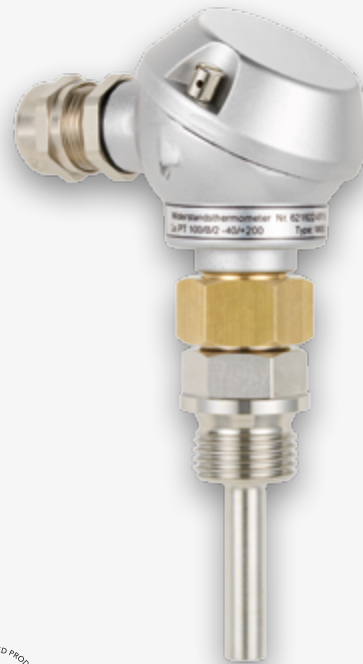

Order code

Order example	W0	8	3	P31	050	2	J0	2
Type								
Resistance thermometer	W0							
Diameter								
8 mm		8						
Material								
Stainless steel 1.4571			3					
Sensor element								
1 x Pt100 3-wire / class B				P31				
2 x Pt100 2-wire / class B				P22				
1 x Pt1000 2-wire / class B				P12				
2 x Pt1000 2-wire / class B				P24				
Resistance thermometer / class A				AXX				
Immersion tube length L1*								
50 mm					050			
80 mm					080			
100 mm					100			
150 mm					150			
Measuring insert								
Interchangeable						2		
Electrical connection								
Head form J with ceramic socket							J0	
Head form J with transmitter** (without approvals)							JT	
Process connection d1*								
G½ A								2
G¼ A								L
G¾ A								3

* Other specifications available on request

** For more information, see chapter temperature transmitters

Type W12

Temperature sensor with connection head form B. This robust sensor is designed for use in industrial and marine applications for measuring the temperature of cooling water, lubricants and hydraulic oil.

Technical features

- High vibration resistance
- One-piece protection tube
- Available with optional instrument transformer
- Customer-specific fitting lengths and fixing thread on request

Sensor element

Resistance thermometer class A and B

Measuring insert

Interchangeable

Diameter

- 12 mm
- 14 mm

Degree of protection

IP54

Max. Temperature

200 °C resistance thermometer

Process connection

Fix connecting thread

Electrical connection

Head form B made of aluminium diecasting, silver finish, max. temperature 200 °C

SW	ØE	K1
32	G¾ A	20
41	M33 x 2	
27	G½ A	14

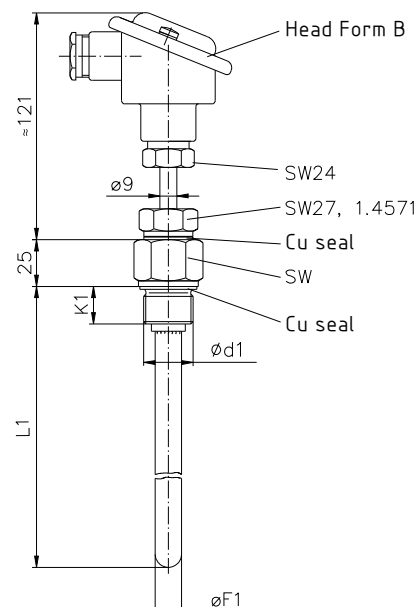

Order code

Order example	W	12	3	P31	080	2	B0	2T2
Type								
Resistance thermometer	W							
Diameter F1								
12 mm		12						
14 mm		14						
Material								
Stainless steel 1.4571			3					
Sensor element								
1 x Pt100 3-wire / class B				P31				
2 x Pt100 3-wire / class B				P32				
1 x Pt100 4-wire / class B				P41				
Resistance thermometer / class A				AXX				
Immersion tube length U1*								
80 mm					080			
100 mm					100			
120 mm					120			
150 mm					150			
200 mm					200			
250 mm					250			
Measuring insert								
Interchangeable						2		
Electrical connection								
Head form B with ceramic socket							B0	
Head form B with transmitter**							BT	
Process connection E*								
G½ A								2T2
G¾ A								3T2
M27 x 2								HT2
M33 x 2								FT2

* Other specifications available on request

** For more information, see our product range "temperature transmitters"

Type WBF

Temperature sensor with protection tube form 2 G / 2F and neck pipe. This sensor is used in industrial applications for measuring liquid and gaseous media.

Technical features

- Neck pipe 125 mm or 25 mm
- Flange DN 25 and DN 40 available
- Available with optional instrument transformer
- Customer-specific fitting lengths and fixing thread on request

Sensor element

- Resistance thermometer class A and B
- Thermocouple class 1

Measuring insert

According to DIN 43735, interchangeable, \varnothing 6 mm or 8 mm
Measuring insert no. 61 or 81

Diameter

- 9 mm
- 11 mm
- 14 mm

Degree of protection

IP54

Max. Temperature

- 400 °C resistance thermometer
- 600 °C on request
- 800 °C thermocouple

Process connection

- Plain immersion tube
- Fix connecting thread

Electrical connection

Head form B made of aluminium diecasting, silver finish, max. temperature 200 °C

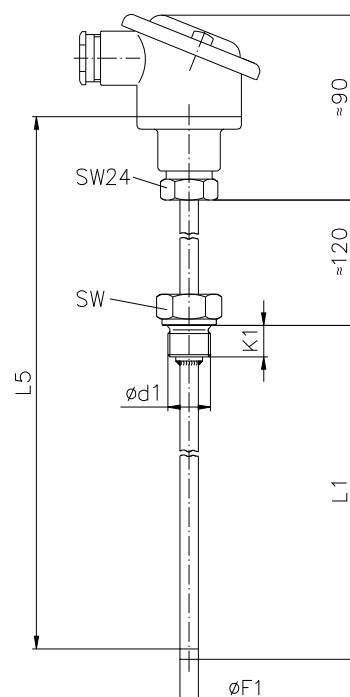
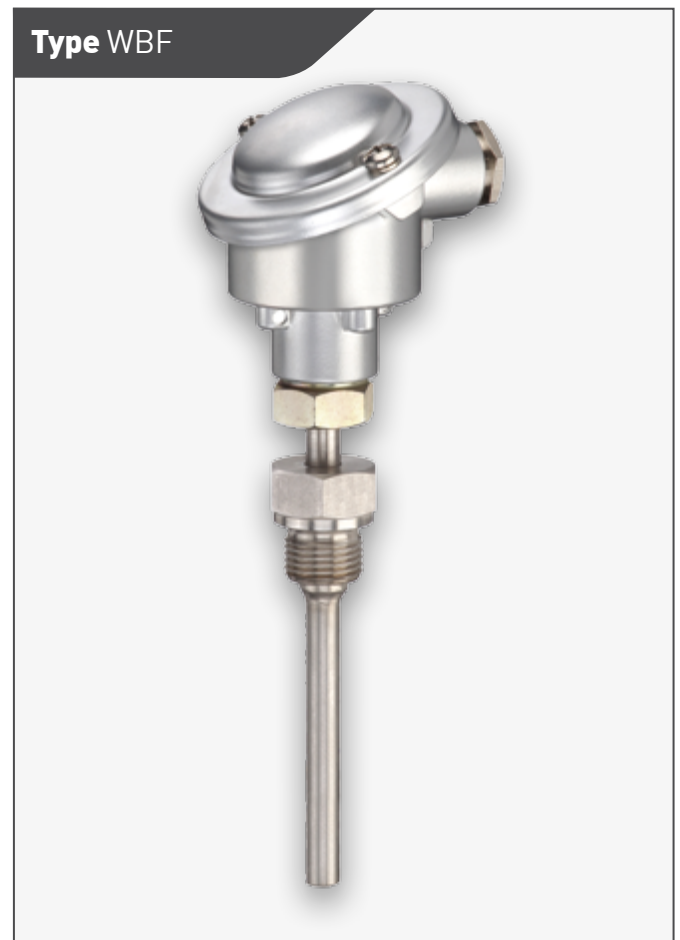

$\varnothing d1$	K1	SW
M20x1,5	15	27
G1/2A		
G1A	30	41

Order code

Order example	WB	B	C	P31	0100	B0	0	00
Type								
Resistance thermometer	WB							
Thermocouple	TB							
Diameter F1								
9 mm		B						
11 mm		D						
14 mm		F						
Material								
Stainless steel 1.4571			C					
Sensor element								
1 x Pt100 3-wire / class B				P31				
2 x Pt100 3-wire / class B				P32				
1 x Pt100 4-wire / class B				P41				
1 x Fe-CuNi (type J)				J11				
2 x Fe-CuNi (type J)				J12				
1 x NiCr-Ni (type K)				K11				
2 x NiCr-Ni (type K)				K12				
Resistance thermometer / class A				AXX				
Length L1* Measuring insert L5*								
100 mm					0100			
160 mm					0160			
250 mm					0250			
400 mm					0400			
Electrical connection								
Head form B with ceramic socket						B0		
Head form B with transmitter**						BT		
Process connection d1*								
Without							0	
G½ A							K	
M20 x 1.5 (no DIN)							G	
G 1 A							L	
Flange DN 25							F25	
Flange DN 40							F40	
Options								
Neck tube 25 mm								00

* Other specifications available on request

** For more information, see chapter temperature transmitters

KombiTemp®

SIKA thermometer with integrated temperature sensor

Technical data	
Type	K 122
Housing	Die cast aluminium, gold-coloured anodised
length	110 mm
width	30 mm
Thermometer capillaries	→ Special glass prismatic → Approx. 6 mm diameter, → black burnt-in scale,
Thermometer filling	Blue
Immersion tube	Diameter 10 x 1 mm
Electrical Connection	Cable socket, angle type DIN EN 175301-803
Immersion tube material	Brass, up to PN 16 bar Stainless steel, up to PN 40 bar
Design	Straight, fixed thread connection

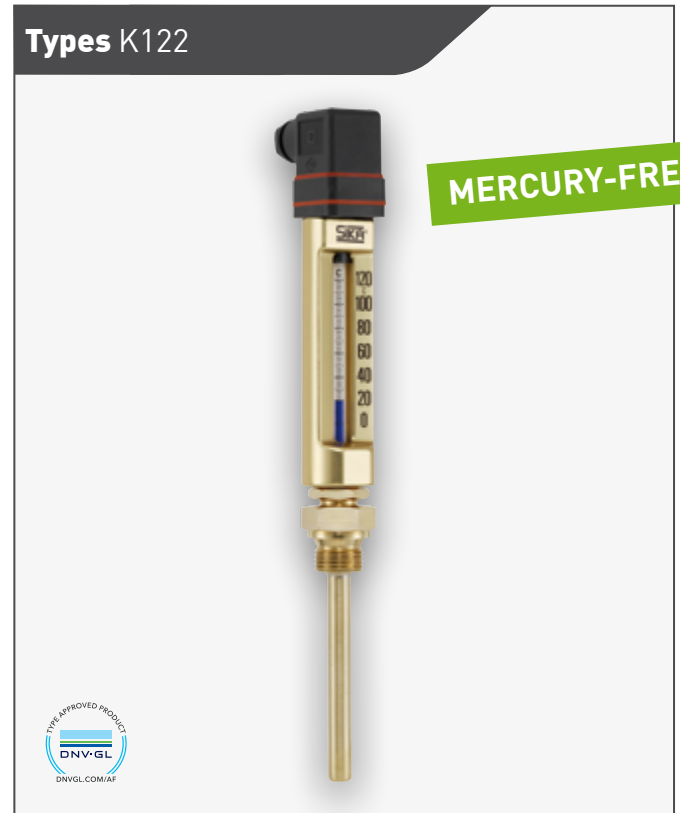

SIKA Order example	K122	35	063	2	1	1	0	ISSA-Code	IMPA-Code
K 122	K122								
Measuring range	-30...50 °C	35							
	0...60 °C	06							
	0...100 °C	10							
	0...120 °C	12							
	0...160 °C	16							
	0...200 °C	20							
Immersion tube length L ₁	63 mm		063					61.231.01	
	100 mm		100					-	
	160 mm		160					61.231.18	
Mechanical connection	G½			2					
	M20 x 1.5			7					
Immersion tube material	Brass (2.0321, for pressure up to 16 bar)				1				
	Stainless steel (1.4571, for pressure up to 40 bar)				3				
Electrical temperature sensor	1x Pt100 / 3-wire / class B					1			
	1x Pt1000 / 2-wire / class B					7			
Scale	°C						0		
	°C and °F						2		

Please ask for customised specifications

Type K 130 for measuring ranges -30...200 °C

Technical data	
Type	K 130
Housing	Die cast aluminium, gold-coloured anodised
length	110 mm
width	30 mm
Thermometer capillaries	→ Special glass prismatic → Approx. 6 mm diameter, → black burnt-in scale,
Thermometer filling	Blue
Immersion tube	Diameter 12 x 1 mm
Electrical Connection	Cable socket, angle type DIN EN 175301-803
Immersion tube material	Brass, up to PN 16 bar Stainless steel, up to PN 40 bar
Design	90°, fixed thread connection

Type K 130



MERCURY-FREE

SIKA Order example	K130	35	063	2	1	1	0	ISSA-Code	IMPA-Code
K 130	K130								
Measuring range	-30...50 °C	35							
	0...60 °C	06							
	0...100 °C	10							
	0...120 °C	12							
	0...160 °C	16							
	0...200 °C	20							
Immersion tube length L₁	63 mm		063						
	100 mm		100						
	160 mm		160						
Mechanical connection	G½				2				
	M20 x 1.5				7				
Immersion tube material	Brass (2.0321, for pressure up to 16 bar)					1			
	Stainless steel (1.4571, for pressure up to 40 bar)					3			
Electrical temperature sensor	1x Pt100 / 3-wire / class B						1		
	1x Pt1000 / 2-wire / class B						4		
	1x Pt1000 / 2-wire						7		
	1x NiCr-Ni (Type K)						2		
	1x Fe-CuNi (Type J)						3		
Scale	°C							0	
	°C and °F							2	